

# Topical Past Papers (2002-2015)

Cambridge International AS and A Level

Physics Paper 1

**9702**

Fully updated classified Past Papers with variants included and years mentioned.

# Contents

- Physical quantities and units
- Measurement and its techniques
- Kinematics
- Kinematics (graphs)
- Projectiles
- Forces
- Dynamics
- Elastic properties
- Phases of matter
- Electric field
- Current Electricity
- Waves
- Superposition
- Nuclear physics

1 Which of the following pairs of units are both SI base units? 9702/1/M/J/02/Q1

- A ampere, degree celsius
- B ampere, kelvin
- C coulomb, degree celsius
- D coulomb, kelvin

2 The diagram shows two vectors X and Y. 9702/1/M/J/02/Q2

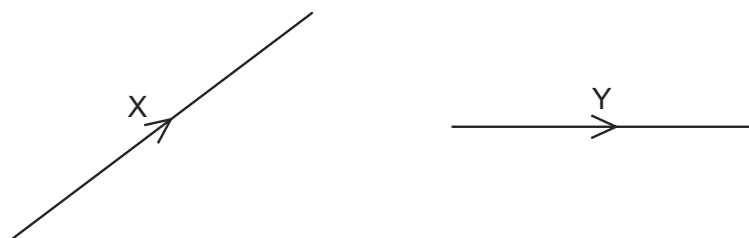

In which vector triangle does the vector Z show the magnitude and direction of vector  $X - Y$ ?

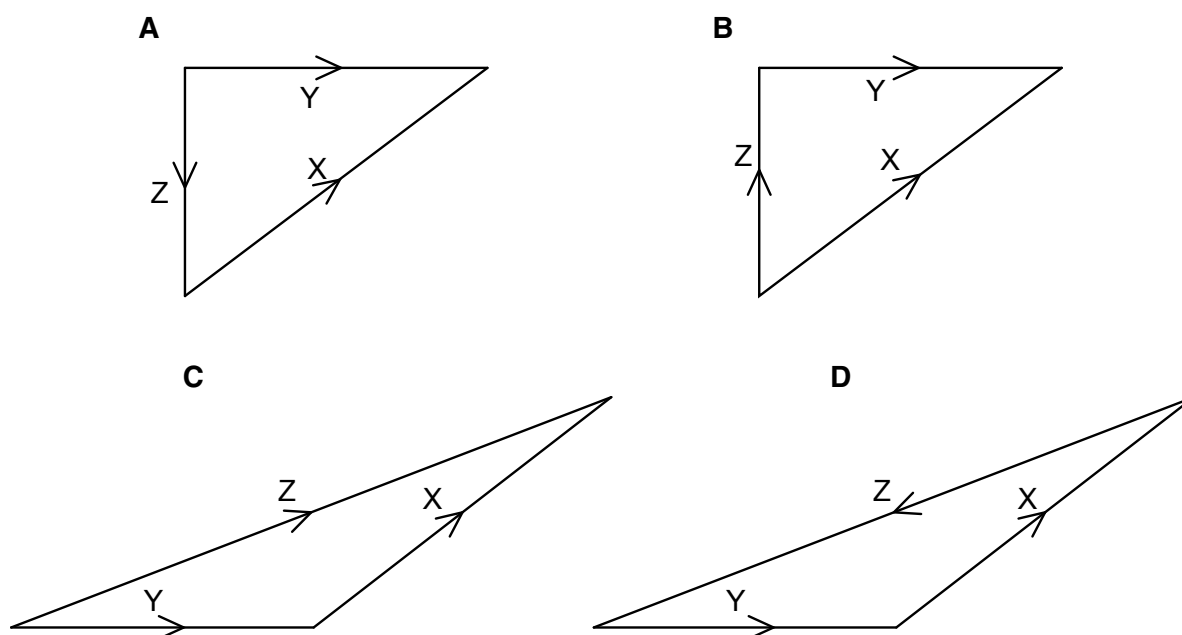

3 Which formula could be correct for the speed  $v$  of ocean waves in terms of the density  $\rho$  of sea-water, the acceleration of free fall  $g$ , the depth  $h$  of the ocean and the wavelength  $\lambda$ ? 9702/1/M/J/02/Q3

- A  $v = \sqrt{g\lambda}$
- B  $v = \sqrt{\frac{g}{h}}$
- C  $v = \sqrt{\rho gh}$
- D  $v = \sqrt{\frac{g}{\rho}}$

- 4 Which of the following is a scalar quantity? 9702/01/M/J/03/Q1
- A acceleration  
B mass  
C momentum  
D velocity
- 5 The unit of work, the joule, may be defined as the work done when the point of application of a force of 1 newton is moved a distance of 1 metre in the direction of the force. 9702/01/M/J/03/Q2
- Express the joule in terms of the base units of mass, length and time, the kg, m and s.
- A  $\text{kg m}^{-1} \text{s}^2$       B  $\text{kg m}^2 \text{s}^{-2}$       C  $\text{kg m}^2 \text{s}^{-1}$       D  $\text{kg s}^{-2}$
- 6 Two forces, each of 10 N, act at a point P as shown in the diagram. The angle between the directions of the forces is  $120^\circ$ . 9702/01/M/J/03/Q3

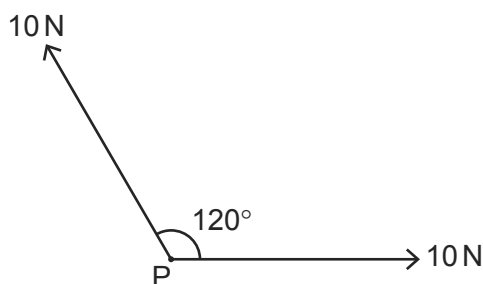

What is the magnitude of the resultant force?

- A 5 N      B 10 N      C 17 N      D 20 N
- 7 A student measures a current as 0.5 A. 9702/01/O/N/03/Q1
- Which of the following correctly expresses this result?
- A 50 mA      B 50 MA      C 500 mA      D 500 MA
- 8 The momentum of an object of mass  $m$  is  $p$ . 9702/01/O/N/03/Q3
- Which quantity has the same base units as  $\frac{p^2}{m}$ ?
- A energy  
B force  
C power  
D velocity

- 9 A force of 5 N may be represented by two perpendicular components OY and OX as shown in the diagram, which is **not** drawn to scale. 9702/01/O/N/03/Q2

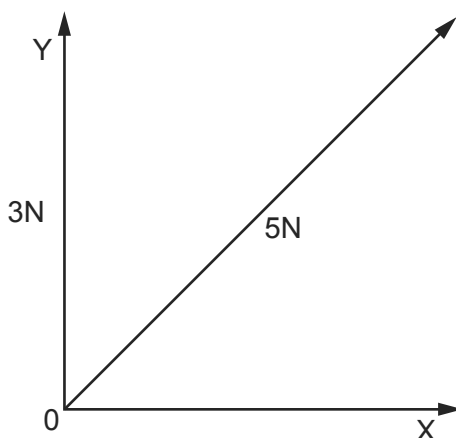

OY is of magnitude 3 N.

What is the magnitude of OX?

- A** 2 N      **B** 3 N      **C** 4 N      **D** 5 N
- 10 Which pair contains one vector and one scalar quantity? 9702/01/M/J/04/Q1
- A** displacement : acceleration  
**B** force : kinetic energy  
**C** momentum : velocity  
**D** power : speed
- 11 Which of the following could be measured in the same units as force? 9702/01/M/J/04/Q2
- A** energy / distance  
**B** energy x distance  
**C** energy / time  
**D** momentum x distance
- 12 The notation  $\mu\text{s}$  is used as an abbreviation for a certain unit of time. 9702/01/M/J/04/Q3

What is the name and value of this unit?

	name	value
<b>A</b>	microsecond	$10^{-6}\text{ s}$
<b>B</b>	microsecond	$10^{-3}\text{ s}$
<b>C</b>	millisecond	$10^{-6}\text{ s}$
<b>D</b>	millisecond	$10^{-3}\text{ s}$

- 13 What is the reading shown on this milliammeter? 9702/01/M/J/04/Q4

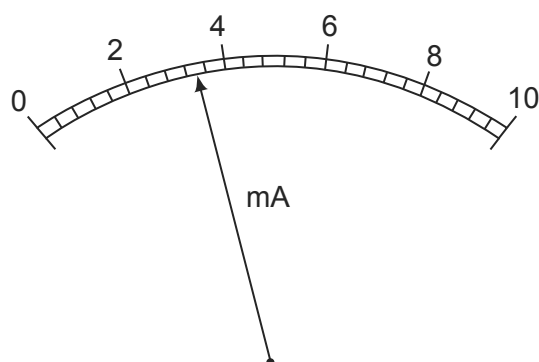

- A** 2.35 mA      **B** 2.7 mA      **C** 3.4 mA      **D** 3.7 mA
- 14 Which line of the table gives values that are equal to a time of 1 ps (one picosecond) and a distance of 1 Gm (one gigametre)? 9702/01/O/N/04/Q1

	time of 1 ps	distance of 1 Gm
<b>A</b>	$10^{-9}$ s	$10^9$ m
<b>B</b>	$10^{-9}$ s	$10^{12}$ m
<b>C</b>	$10^{-12}$ s	$10^9$ m
<b>D</b>	$10^{-12}$ s	$10^{12}$ m

- 15 Which of the following definitions is correct and uses only quantities rather than units? 9702/01/O/N/04/Q2
- A** Density is mass per cubic metre.  
**B** Potential difference is energy per unit current.  
**C** Pressure is force per unit area.  
**D** Speed is distance travelled per second.
- 16 When a beam of light is incident on a surface, it delivers energy to the surface. The intensity of the beam is defined as the energy delivered per unit area per unit time. 9702/01/O/N/04/Q3

What is the unit of intensity, expressed in SI base units?

- A**  $\text{kg m}^{-2} \text{s}^{-1}$       **B**  $\text{kg m}^2 \text{s}^{-3}$       **C**  $\text{kg s}^{-2}$       **D**  $\text{kg s}^{-3}$
- 17 An Olympic athlete of mass 80 kg competes in a 100 m race. 9702/01/M/J/05/Q3
- What is the best estimate of his mean kinetic energy during the race?
- A**  $4 \times 10^2$  J      **B**  $4 \times 10^3$  J      **C**  $4 \times 10^4$  J      **D**  $4 \times 10^5$  J

- 18 Decimal sub-multiples and multiples of units are indicated using a prefix to the unit. For example, the prefix milli (m) represents  $10^{-3}$ . 9702/01/M/J/05/Q1

Which of the following gives the sub-multiples or multiples represented by pico (p) and giga (G)?

	pico (p)	giga (G)
<b>A</b>	$10^{-9}$	$10^9$
<b>B</b>	$10^{-9}$	$10^{12}$
<b>C</b>	$10^{-12}$	$10^9$
<b>D</b>	$10^{-12}$	$10^{12}$

- 19 A metal sphere of radius  $r$  is dropped into a tank of water. As it sinks at speed  $v$ , it experiences a drag force  $F$  given by  $F = kr v$ , where  $k$  is a constant. 9702/01/M/J/05/Q2

What are the SI base units of  $k$ ?

- A**  $\text{kg m}^2 \text{s}^{-1}$       **B**  $\text{kg m}^{-2} \text{s}^{-2}$       **C**  $\text{kg m}^{-1} \text{s}^{-1}$       **D**  $\text{kg m s}^{-2}$

- 20 Which pair of units are both SI base units? 9702/01/O/N/05/Q1

- A** ampere, degree celsius  
**B** ampere, kelvin  
**C** coulomb, degree celsius  
**D** coulomb, kelvin

- 21 The prefix 'centi' indicates  $\times 10^{-2}$ . 9702/01/O/N/05/Q2

Which line in the table correctly indicates the prefixes micro, nano and pico?

	$\times 10^{-12}$	$\times 10^{-9}$	$\times 10^{-6}$
<b>A</b>	nano	micro	pico
<b>B</b>	nano	pico	micro
<b>C</b>	pico	nano	micro
<b>D</b>	pico	micro	nano

- 22 Which expression involving base units is equivalent to the volt? 9702/01/O/N/05/Q3

- A**  $\text{kg m}^2 \text{s}^{-1} \text{A}^{-1}$   
**B**  $\text{kg m s}^{-2} \text{A}$   
**C**  $\text{kg m}^2 \text{s}^{-1} \text{A}$   
**D**  $\text{kg m}^2 \text{s}^{-3} \text{A}^{-1}$

- 23 Which pair includes a vector quantity and a scalar quantity? 9702/01/M/J/06/Q1
- A** displacement; acceleration  
**B** force; kinetic energy  
**C** power; speed  
**D** work; potential energy
- 24 For which quantity is the magnitude a reasonable estimate? 9702/01/M/J/06/Q2
- A** frequency of a radio wave 500 pHz  
**B** mass of an atom 500  $\mu\text{g}$   
**C** the Young modulus of a metal 500 kPa  
**D** wavelength of green light 500 nm
- 25 The following physical quantities can be either positive or negative. 9702/01/M/J/06/Q3

$s$  : displacement of a particle along a straight line

$\theta$  : temperature on the Celsius scale

$q$  : electric charge

$V$  : readings on a digital voltmeter

Which of these quantities are vectors?

- A**  $s, \theta, q, V$   
**B**  $s, q, V$   
**C**  $\theta, V$   
**D**  $s$  only
- 26 In the expressions below 9702/01/O/N/06/Q2

$a$  is acceleration,

$F$  is force,

$m$  is mass,

$t$  is time,

$v$  is velocity.

Which expression represents energy?

- A**  $Ft$                       **B**  $Fvt$                       **C**  $\frac{2mv}{t}$                       **D**  $\frac{at^2}{2}$



27 Which product-pair of metric prefixes has the greatest magnitude? 9702/01/O/N/06/Q1

- A pico  $\times$  mega
- B nano  $\times$  kilo
- C micro  $\times$  giga
- D milli  $\times$  tera

28 Which row of the table shows a physical quantity and its correct unit? 9702/01/O/N/06/Q3

	physical quantity	unit
<b>A</b>	electric field strength	$\text{kg m s}^{-2} \text{C}^{-1}$
<b>B</b>	specific heat capacity	$\text{kg}^{-1} \text{m}^2 \text{s}^{-2} \text{K}^{-1}$
<b>C</b>	tensile strain	$\text{kg m}^{-1} \text{s}^{-2}$
<b>D</b>	the Young modulus	$\text{kg m}^{-1} \text{s}^{-3}$

29 Which is a pair of SI base units? 9702/01/M/J/07/Q1

<b>A</b>	ampere	joule
<b>B</b>	coulomb	second
<b>C</b>	kilogram	kelvin
<b>D</b>	metre	newton

30 What is the ratio  $\frac{1 \mu\text{m}}{1 \text{Gm}}$ ? 9702/01/M/J/07/Q2

- A  $10^{-3}$
- B  $10^{-9}$
- C  $10^{-12}$
- D  $10^{-15}$

31 Which formula could be correct for the speed  $v$  of ocean waves in terms of the density  $\rho$  of sea-water, the acceleration of free fall  $g$ , the depth  $h$  of the ocean and the wavelength  $\lambda$ ? 9702/01/M/J/07/Q3

- A  $v = \sqrt{g\lambda}$
- B  $v = \sqrt{\frac{g}{h}}$
- C  $v = \sqrt{\rho gh}$
- D  $v = \sqrt{\frac{g}{\rho}}$

32 Which of the following correctly expresses the volt in terms of SI base units? 9702/01/M/J/08/Q2

- A  $\text{A}\Omega$
- B  $\text{W}\text{A}^{-1}$
- C  $\text{kg m}^2 \text{s}^{-1} \text{A}^{-1}$
- D  $\text{kg m}^2 \text{s}^{-3} \text{A}^{-1}$

- 33 The equation relating pressure and density is  $p = \rho gh$ . 9702/01/O/N/07/Q1

How can both sides of this equation be written in terms of base units?

- A  $[\text{N m}^{-1}] = [\text{kg m}^{-3}] [\text{m s}^{-1}] [\text{m}]$   
 B  $[\text{N m}^{-2}] = [\text{kg m}^{-3}] [\text{m s}^{-2}] [\text{m}]$   
 C  $[\text{kg m}^{-1} \text{s}^{-2}] = [\text{kg m}^{-3}] [\text{m s}^{-2}] [\text{m}]$   
 D  $[\text{kg m}^{-1} \text{s}^{-1}] = [\text{kg m}^{-1}] [\text{m s}^{-2}] [\text{m}]$
- 34 What is a reasonable estimate of the diameter of an alpha particle? 9702/01/O/N/07/Q2
- A  $10^{-15} \text{ m}$       B  $10^{-12} \text{ m}$       C  $10^{-9} \text{ m}$       D  $10^{-6} \text{ m}$

- 35 The diagram shows two vectors **X** and **Y**.

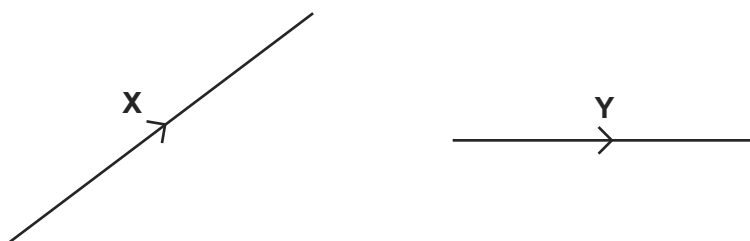

In which vector triangle does the vector **Z** show the magnitude and direction of vector **X–Y**?

9702/01/O/N/07/Q3

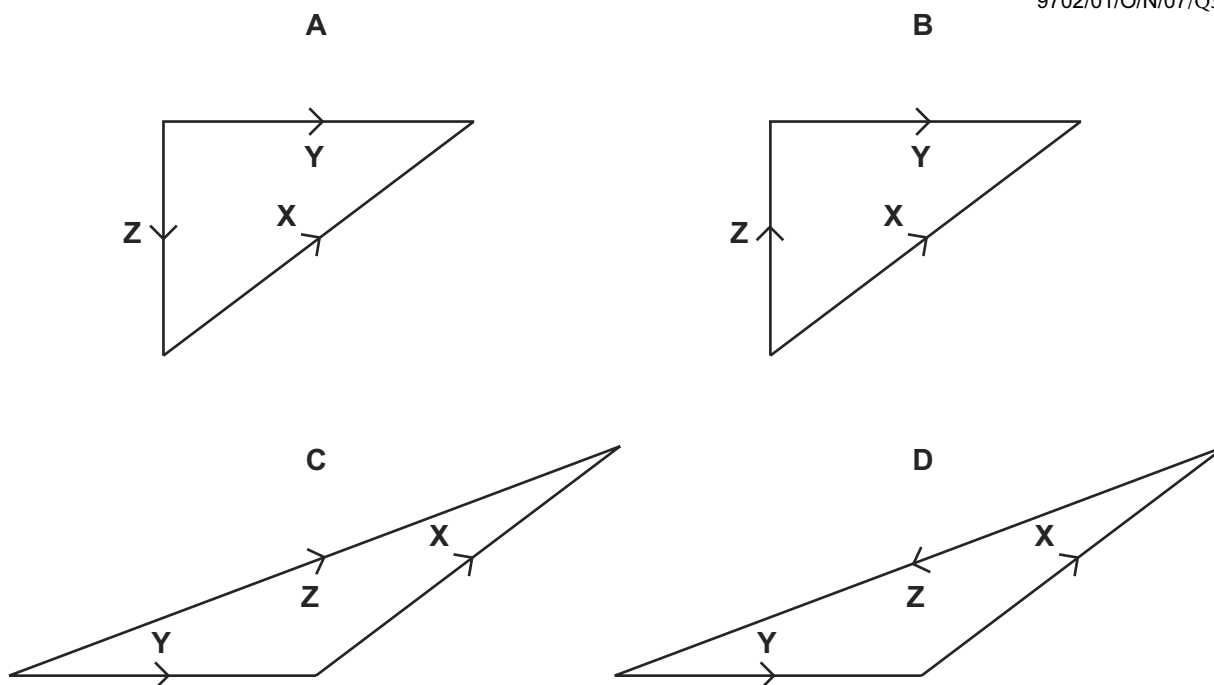

36 Five energies are listed. 9702/01/M/J/08/Q1

5 kJ

5 mJ

5 MJ

5 nJ

Starting with the smallest first, what is the order of increasing magnitude of these energies?

**A** 5 kJ → 5 mJ → 5 MJ → 5 nJ

**B** 5 nJ → 5 kJ → 5 MJ → 5 mJ

**C** 5 nJ → 5 mJ → 5 kJ → 5 MJ

**D** 5 mJ → 5 nJ → 5 kJ → 5 MJ

37 What is a reasonable estimate of the average kinetic energy of an athlete during a 100 m race that takes 10 s? 9702/01/M/J/08/Q3

**A** 40 J

**B** 400 J

**C** 4000 J

**D** 40 000 J

38 At temperatures close to 0 K, the specific heat capacity  $c$  of a particular solid is given by  $c = bT^3$ , where  $T$  is the thermodynamic temperature and  $b$  is a constant characteristic of the solid.

What are the units of constant  $b$ , expressed in SI base units?

9702/01/O/N/08/Q2

**A**  $\text{m}^2 \text{s}^{-2} \text{K}^{-3}$

**B**  $\text{m}^2 \text{s}^{-2} \text{K}^{-4}$

**C**  $\text{kg m}^2 \text{s}^{-2} \text{K}^{-3}$

**D**  $\text{kg m}^2 \text{s}^{-2} \text{K}^{-4}$

39 The table shows the  $x$ -component and  $y$ -component of four force vectors.

9702/01/O/N/08/Q3

Which force vector has the largest magnitude?

	$x$ -component/N	$y$ -component/N
<b>A</b>	2	9
<b>B</b>	3	8
<b>C</b>	4	7
<b>D</b>	5	6

- 40 A laser emits light of wavelength 600 nm.

9702/01/O/N/08/Q1

What is the distance, expressed as a number of wavelengths, travelled by the light in one second?

- A**  $5 \times 10^8$       **B**  $5 \times 10^{11}$       **C**  $5 \times 10^{14}$       **D**  $5 \times 10^{17}$
- 41 Which statement, involving multiples and sub-multiples of the base unit metre (m), is correct?
- A**  $1 \text{ pm} = 10^{-9} \text{ m}$   
**B**  $1 \text{ nm} = 10^{-6} \text{ m}$   
**C**  $1 \text{ mm} = 10^6 \mu\text{m}$   
**D**  $1 \text{ km} = 10^6 \text{ mm}$
- 42 The diagram shows a resultant force and its horizontal and vertical components.

9702/01/M/J/09/Q1

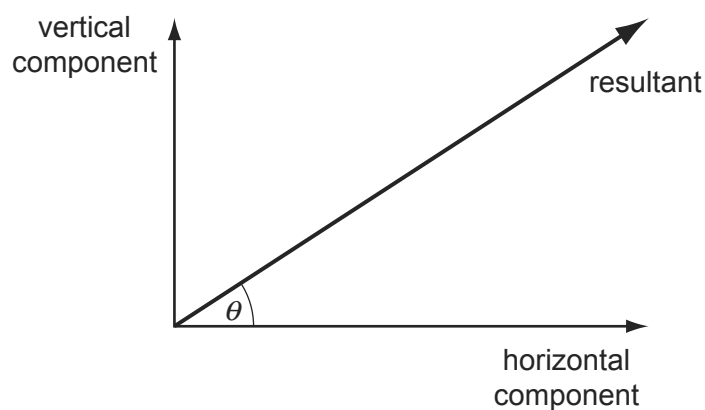

The horizontal component is 20.0 N and  $\theta = 30^\circ$ . What is the vertical component?

- A** 8.7 N      **B** 10.0 N      **C** 11.5 N      **D** 17.3 N
- 43 The table contains some quantities, together with their symbols and units.

9702/11/O/N/09/Q2

quantity	symbol	unit
gravitational field strength	$g$	$\text{N kg}^{-1}$
density of liquid	$\rho$	$\text{kg m}^{-3}$
vertical height	$h$	m
volume of part of liquid	$V$	$\text{m}^3$

Which expression has the units of energy?

- A**  $g\rho hV$       **B**  $\frac{\rho hV}{g}$       **C**  $\frac{\rho g}{hV}$       **D**  $\rho g^2 h$

- 44 The drag force  $F$  acting on a moving sphere obeys an equation of the form  $F = kAv^2$ , where  $A$  represents the sphere's frontal area and  $v$  represents its speed. 9702/11/O/N/09/Q1

What are the base units of the constant  $k$ ?

- A**  $\text{kg m}^5 \text{s}^{-4}$       **B**  $\text{kg m}^{-2} \text{s}^{-1}$       **C**  $\text{kg m}^{-3}$       **D**  $\text{kg m}^{-4} \text{s}^2$

- 45 The drag force  $F$  acting on a moving sphere obeys an equation of the form  $F = kAv^2$ , where  $A$  represents the sphere's frontal area and  $v$  represents its speed. 9702/12/O/N/09/Q1

What are the base units of the constant  $k$ ?

- A**  $\text{kg m}^5 \text{s}^{-4}$       **B**  $\text{kg m}^{-2} \text{s}^{-1}$       **C**  $\text{kg m}^{-3}$       **D**  $\text{kg m}^{-4} \text{s}^2$

- 46 The graph shows two current-voltage calibration curves for a solar cell exposed to different light intensities. 9702/12/O/N/09/Q2

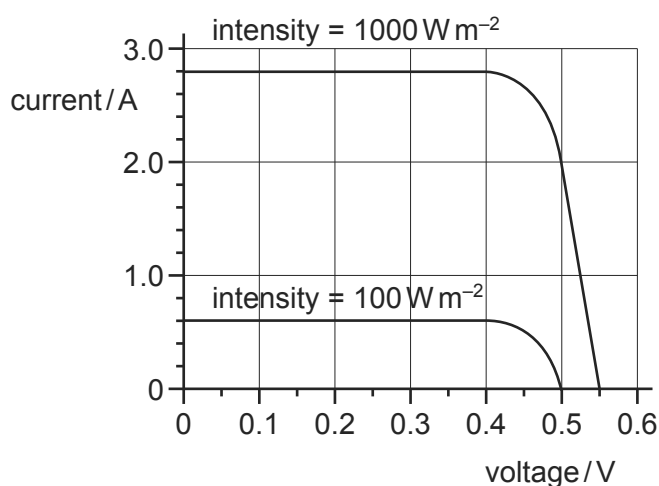

At zero voltage, what is the ratio  $\frac{\text{current at } 1000 \text{ W m}^{-2}}{\text{current at } 100 \text{ W m}^{-2}}$ ?

- A** 1.1      **B** 4.7      **C** 8.0      **D** 10

- 47 The SI unit for potential difference (the volt) is given, in base units, by 9702/11/M/J/10/Q1

- A**  $\text{kg m A}^{-1} \text{s}^{-3}$ .  
**B**  $\text{m}^2 \text{A}^{-1} \text{s}^{-2}$ .  
**C**  $\text{kg m}^2 \text{s}^{-2}$ .  
**D**  $\text{kg m}^2 \text{A}^{-1} \text{s}^{-3}$ .

- 48 A signal has a frequency of 2.0 MHz. 9702/11/O/N/10/Q1

What is the period of the signal?

- A**  $2 \mu\text{s}$       **B**  $5 \mu\text{s}$       **C** 200 ns      **D** 500 ns

49 The product of pressure and volume has the same SI base units as 9702/11/M/J/10/Q2

- A energy.
- B force.
- C  $\frac{\text{force}}{\text{area}}$ .
- D  $\frac{\text{force}}{\text{length}}$ .

50 An ion is accelerated by a series of electrodes in a vacuum. A graph of the power supplied to the ion is plotted against time. 9702/11/M/J/10/Q3

What is represented by the area under the graph between two times?

- A the change in kinetic energy of the ion
- B the average force on the ion
- C the change in momentum of the ion
- D the change in velocity of the ion

51 A micrometer screw gauge is used to measure the diameter of a copper wire. 9702/12/M/J/10/Q1

The reading with the wire in position is shown in diagram 1. The wire is removed and the jaws of the micrometer are closed. The new reading is shown in diagram 2.

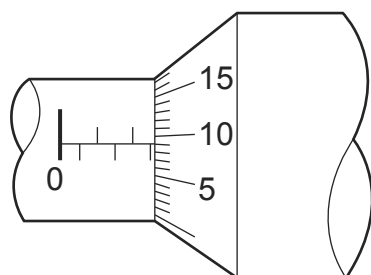

diagram 1

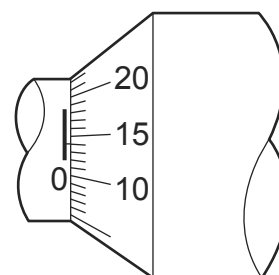

diagram 2

What is the diameter of the wire?

- A 1.90 mm
- B 2.45 mm
- C 2.59 mm
- D 2.73 mm

52 The SI unit for potential difference (the volt) is given, in base units, by 9702/12/M/J/10/Q2

- A  $\text{kg m A}^{-1} \text{s}^{-3}$ .
- B  $\text{m}^2 \text{A}^{-1} \text{s}^{-2}$ .
- C  $\text{kg m}^2 \text{s}^{-2}$ .
- D  $\text{kg m}^2 \text{A}^{-1} \text{s}^{-3}$ .

53 The product of pressure and volume has the same SI base units as 9702/13/M/J/10/Q1

- A energy.
- B force.
- C  $\frac{\text{force}}{\text{area}}$ .
- D  $\frac{\text{force}}{\text{length}}$ .

54 A vector quantity  $V$  is resolved into two perpendicular components  $X$  and  $Y$ . The angle between  $V$  and component  $X$  is  $\theta$ . 9702/13/M/J/10/Q2

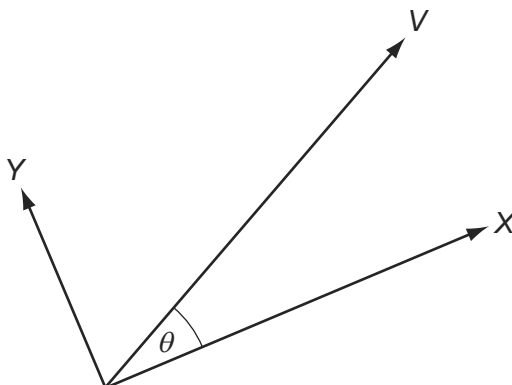

The angle between component  $X$  and the vector  $V$  is increased from  $0^\circ$  to  $90^\circ$ .

How do the magnitudes of  $X$  and  $Y$  change as the angle  $\theta$  is increased in this way?

	$X$	$Y$
A	increase	increase
B	increase	decrease
C	decrease	increase
D	decrease	decrease

55 Which physical quantity would result from a calculation in which a potential difference is multiplied by an electric charge? 9702/11/O/N/10/Q3

- A electric current
- B electric energy
- C electric field strength
- D electric power

56 A metal sphere of radius  $r$  is dropped into a tank of water. As it sinks at speed  $v$ , it experiences a drag force  $F$  given by  $F = kr v$ , where  $k$  is a constant. 9702/11/O/N/10/Q2

What are the SI base units of  $k$ ?

- A  $\text{kg m}^2 \text{s}^{-1}$
- B  $\text{kg m}^{-2} \text{s}^{-2}$
- C  $\text{kg m}^{-1} \text{s}^{-1}$
- D  $\text{kg m s}^{-2}$

57 Which row shows a base quantity with its correct SI unit? 9702/12/O/N/10/Q1

	quantity	unit
<b>A</b>	current	A
<b>B</b>	mass	g
<b>C</b>	temperature	°C
<b>D</b>	weight	N

58 The frictional force  $F$  on a sphere falling through a fluid is given by the formula 9702/12/O/N/10/Q2

$$F = 6\pi a\eta v$$

where  $a$  is the radius of the sphere,  $\eta$  is a constant relating to the fluid and  $v$  is the velocity of the sphere.

What are the units of  $\eta$ ?

- A**  $\text{kg m s}^{-1}$       **B**  $\text{kg m}^{-1} \text{s}^{-1}$       **C**  $\text{kg m s}^{-3}$       **D**  $\text{kg m}^3 \text{s}^{-3}$

59 What is the component of this displacement vector in the direction XY? 9702/12/O/N/10/Q3

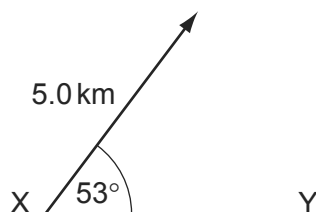

- A** 3.0 km      **B** 4.0 km      **C** 5.0 km      **D** 6.6 km

60 Which physical quantity would result from a calculation in which a potential difference is multiplied by an electric charge? 9702/13/O/N/10/Q1

- A** electric current  
**B** electric energy  
**C** electric field strength  
**D** electric power

61 Which definition is correct and uses only quantities rather than units? 9702/11/M/J/11/Q2

- A** Density is mass per cubic metre.  
**B** Potential difference is energy per unit current.  
**C** Pressure is force per unit area.  
**D** Speed is distance travelled per second.



- 62 Decimal sub-multiples and multiples of units are indicated using a prefix to the unit. For example, the prefix milli (m) represents  $10^{-3}$ .

Which row gives the sub-multiples or multiples represented by pico (p) and giga (G)? 9702/11/M/J/11/Q1

	pico (p)	giga (G)
<b>A</b>	$10^{-9}$	$10^9$
<b>B</b>	$10^{-9}$	$10^{12}$
<b>C</b>	$10^{-12}$	$10^9$
<b>D</b>	$10^{-12}$	$10^{12}$

- 63 A force of 5.0 N pushes a ball due north and another force of 3.0 N pushes it due east. 9702/11/M/J/11/Q3

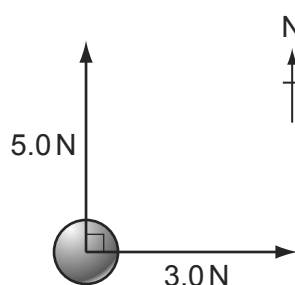

What is the magnitude of the net force acting on the ball?

- A** 2.8 N      **B** 4.0 N      **C** 5.8 N      **D** 8.0 N
- 64 Stress has the same SI base units as 9702/12/M/J/11/Q1

- A**  $\frac{\text{force}}{\text{mass}}$ .
- B**  $\frac{\text{force}}{\text{length}}$ .
- C**  $\frac{\text{force}}{\text{area}}$ .
- D** energy.

- 65 To check calculations, the units are put into the following equations together with the numbers.

Which equation must be **incorrect**? 9702/12/M/J/11/Q2

- A** force = 300 J / 6 m
- B** power = 6000 J  $\times$  20 s
- C** time = 6 m / 30 m s<sup>-1</sup>
- D** velocity = 4 m s<sup>-2</sup>  $\times$  30 s

- 66 In making reasonable estimates of physical quantities, which statement is **not** correct?

9702/12/M/J/11/Q3

- A** The frequency of sound can be of the order of GHz.  
**B** The wavelength of light can be of the order of 600 nm.  
**C** The Young modulus can be of the order of  $10^{11}$  Pa.  
**D** Beta radiation is associated with one unit of negative charge.

- 67 A force of 5.0 N pushes a ball due north and another force of 3.0 N pushes it due east.

9702/13/M/J/11/Q1

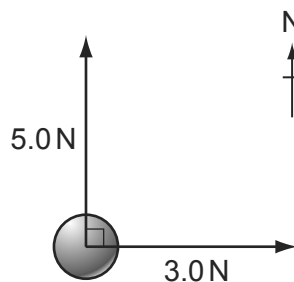

What is the magnitude of the net force acting on the ball?

- A** 2.8 N                      **B** 4.0 N                      **C** 5.8 N                      **D** 8.0 N
- 68 Decimal sub-multiples and multiples of units are indicated using a prefix to the unit. For example, the prefix milli (m) represents  $10^{-3}$ .

Which row gives the sub-multiples or multiples represented by pico (p) and giga (G)? 9702/13/M/J/11/Q2

	pico (p)	giga (G)
<b>A</b>	$10^{-9}$	$10^9$
<b>B</b>	$10^{-9}$	$10^{12}$
<b>C</b>	$10^{-12}$	$10^9$
<b>D</b>	$10^{-12}$	$10^{12}$

- 69 Which definition is correct and uses only quantities rather than units? 9702/13/M/J/11/Q3

- A** Density is mass per cubic metre.  
**B** Potential difference is energy per unit current.  
**C** Pressure is force per unit area.  
**D** Speed is distance travelled per second.

- 70 An Olympic athlete of mass 80 kg competes in a 100 m race. 9702/11/O/N/11/Q2

What is the best estimate of his mean kinetic energy during the race?

- A**  $4 \times 10^2$  J                      **B**  $4 \times 10^3$  J                      **C**  $4 \times 10^4$  J                      **D**  $4 \times 10^5$  J

71 Which statement using prefixes of the base unit metre (m) is **not** correct? 9702/11/O/N/11/Q1

- A 1 pm =  $10^{-12}$  m
- B 1 nm =  $10^{-9}$  m
- C 1 Mm =  $10^6$  m
- D 1 Gm =  $10^{12}$  m

72 Which group of quantities contains only vectors? 9702/11/O/N/11/Q3

- A acceleration, displacement, speed
- B acceleration, work, electric field strength
- C displacement, force, velocity
- D power, electric field strength, force

73 A cylindrical tube rolling down a slope of inclination  $\theta$  moves a distance  $L$  in time  $T$ . The equation relating these quantities is

$$L \left( 3 + \frac{a^2}{P} \right) = QT^2 \sin \theta$$

Where  $a$  is the internal radius of the tube and  $P$  and  $Q$  are constants. 9702/11/O/N/11/Q4

Which line gives the correct units for  $P$  and  $Q$ ?

	$P$	$Q$
<b>A</b>	$m^2$	$m^2 s^{-2}$
<b>B</b>	$m^2$	$m s^{-2}$
<b>C</b>	$m^2$	$m^3 s^{-2}$
<b>D</b>	$m^3$	$ms^{-2}$

74 Which quantity can be measured in electronvolts (eV)? 9702/12/O/N/11/Q1

- A electric charge
- B electric potential
- C energy
- D power

75 What is the ratio  $\frac{10^{-3} \text{ THz}}{10^3 \text{ kHz}}$ ? 9702/12/O/N/11/Q2

- A  $10^{-9}$
- B  $10^{-6}$
- C  $10^0$
- D  $10^3$

76 The following physical quantities can be either positive or negative.

9702/12/O/N/11/Q3

$s$  : displacement of a particle along a straight line

$\theta$  : temperature on the Celsius scale

$q$  : electric charge

$V$  : readings on a digital voltmeter

Which of these quantities are vectors?

- A**  $s, \theta, q, V$       **B**  $s, q, V$  only      **C**  $\theta, V$  only      **D**  $s$  only

77 Which group of quantities contains only vectors?

9702/13/O/N/11/Q1

- A** acceleration, displacement, speed  
**B** acceleration, work, electric field strength  
**C** displacement, force, velocity  
**D** power, electric field strength, force

78 Which statement using prefixes of the base unit metre (m) is **not** correct?

9702/13/O/N/11/Q2

- A**  $1 \text{ pm} = 10^{-12} \text{ m}$   
**B**  $1 \text{ nm} = 10^{-9} \text{ m}$   
**C**  $1 \text{ Mm} = 10^6 \text{ m}$   
**D**  $1 \text{ Gm} = 10^{12} \text{ m}$

79 When a force  $F$  moves its point of application through a displacement  $s$  in the direction of the force, the work  $W$  done by the force is given by

9702/11/M/J/12/Q1

$$W = Fs.$$

How many vector quantities and scalar quantities does this equation contain?

- A** one scalar quantity and two vector quantities  
**B** one vector quantity and two scalar quantities  
**C** three scalar quantities  
**D** three vector quantities

80 What is a reasonable estimate of the average kinetic energy of an athlete during a 100 m race that takes 10 s?

9702/11/M/J/12/Q3

- A** 40 J      **B** 400 J      **C** 4000 J      **D** 40 000 J

- 81 What is a possible unit for the product  $VI$ , where  $V$  is the potential difference across a resistor and  $I$  is the current through the same resistor?

9702/11/M/J/12/Q2

- A** newton per second ( $\text{Ns}^{-1}$ )  
**B** newton second ( $\text{Ns}$ )  
**C** newton metre ( $\text{Nm}$ )  
**D** newton metre per second ( $\text{Nms}^{-1}$ )

- 82 What is the unit watt in terms of SI base units?

9702/12/M/J/12/Q1

- A**  $\text{Js}^{-1}$       **B**  $\text{m}^2\text{kg s}^{-1}$       **C**  $\text{m}^2\text{kg s}^{-3}$       **D**  $\text{Nms}^{-1}$

- 83 For which quantity is the magnitude a reasonable estimate?

9702/12/M/J/12/Q2

- A** frequency of a radio wave      500 pHz  
**B** mass of an atom      500  $\mu\text{g}$   
**C** the Young modulus of a metal      500 kPa  
**D** wavelength of green light      500 nm

- 84 A vector has magnitude  $R$  and perpendicular components  $P$  and  $Q$ , as shown in the diagram.

9702/12/M/J/12/Q3

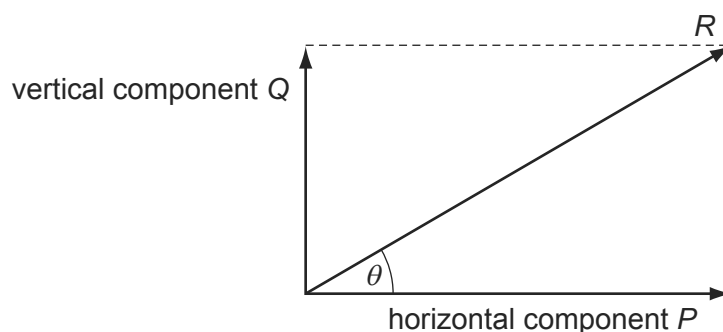

Which row correctly describes the perpendicular components?

	vertical component	horizontal component
<b>A</b>	$Q$	$R \sin \theta$
<b>B</b>	$R \cos \theta$	$P$
<b>C</b>	$R \cos \theta$	$R \sin \theta$
<b>D</b>	$R \sin \theta$	$R \cos \theta$

- 85 What is a reasonable estimate of the average kinetic energy of an athlete during a 100 m race that takes 10 s?

9702/13/M/J/12/Q1

- A** 40 J      **B** 400 J      **C** 4000 J      **D** 40 000 J

- 86 When a force  $F$  moves its point of application through a displacement  $s$  in the direction of the force, the work  $W$  done by the force is given by

9702/13/M/J/12/Q2

$$W = Fs.$$

How many vector quantities and scalar quantities does this equation contain?

- A** one scalar quantity and two vector quantities  
**B** one vector quantity and two scalar quantities  
**C** three scalar quantities  
**D** three vector quantities
- 87 What is a possible unit for the product  $VI$ , where  $V$  is the potential difference across a resistor and  $I$  is the current through the same resistor?
- A** newton per second ( $\text{Ns}^{-1}$ )  
**B** newton second ( $\text{Ns}$ )  
**C** newton metre ( $\text{Nm}$ )  
**D** newton metre per second ( $\text{Nms}^{-1}$ )

9702/13/M/J/12/Q3

- 88 What is the unit of weight in terms of SI base unit(s)?

9702/11/O/N/12/Q1

- A**  $\text{kgms}^{-1}$       **B**  $\text{kgms}^{-2}$       **C**  $\text{N}$       **D**  $\text{Jm}^{-1}$

- 89 Vectors  $P$  and  $Q$  are drawn to scale.

9702/11/O/N/12/Q2



Which diagram represents the vector  $(P - Q)$ ?

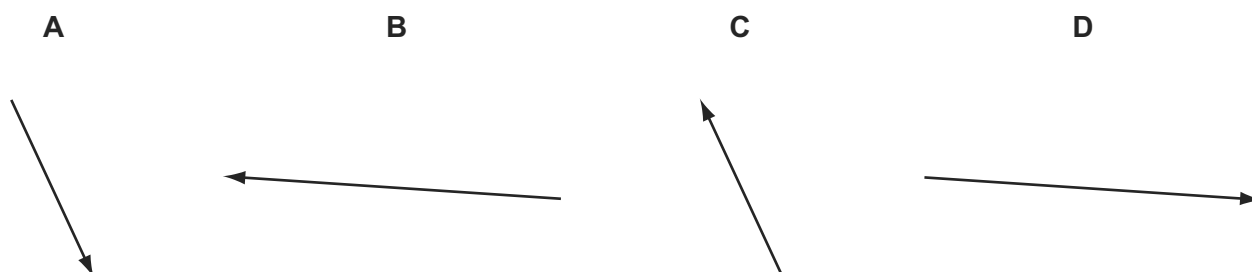

- 90 What is the approximate temperature of a red-hot ring on an electric cooker?

9702/11/O/N/12/Q3

- A**  $100^\circ\text{C}$       **B**  $200^\circ\text{C}$       **C**  $400^\circ\text{C}$       **D**  $800^\circ\text{C}$

91 Which quantity has the same base units as momentum?

9702/12/O/N/12/Q1

- A density  $\times$  energy
- B density  $\times$  volume  $\times$  velocity
- C pressure  $\times$  area
- D weight  $\div$  area

92 Vectors P and Q are drawn to scale.

9702/12/O/N/12/Q2



Which diagram represents the vector  $(P + Q)$ ?

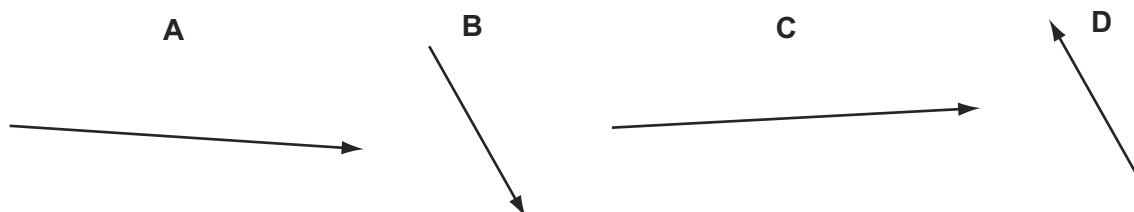

93 What is the approximate kinetic energy of an Olympic athlete when running at maximum speed during a 100 m race?

9702/12/O/N/12/Q3

- A 400 J
- B 4000 J
- C 40 000 J
- D 400 000 J

94 Physical quantities can be classed as vectors or as scalars.

9702/12/O/N/12/Q4

Which pair of quantities are both vectors?

- A kinetic energy and elastic force
- B momentum and time
- C velocity and electric field strength
- D weight and temperature

95 Which list contains only scalar quantities?

9702/11/O/N/12/Q4

- A area, length, displacement
- B kinetic energy, speed, power
- C potential energy, momentum, time
- D velocity, distance, temperature

96 The units of all physical quantities can be expressed in terms of SI base units.

9702/13/O/N/12/Q1

Which pair contains quantities with the same base units?

- A force and momentum
- B pressure and Young modulus
- C power and kinetic energy
- D mass and weight

97 Two physical quantities  $P$  and  $Q$  are added. The sum of  $P$  and  $Q$  is  $R$ , as shown.

9702/13/O/N/12/Q2

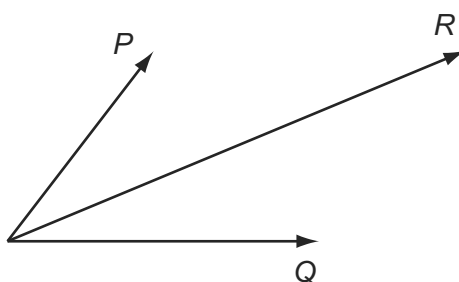

Which quantity could be represented by  $P$  and by  $Q$ ?

- A kinetic energy
- B power
- C speed
- D velocity

98 A 1.5 V cell supplies 0.20 A to a lamp for seven hours before the lamp goes out.

9702/13/O/N/12/Q3

What is a sensible estimate for the initial chemical energy content of the cell?

- A  $1 \times 10^2 \text{ J}$       B  $1 \times 10^4 \text{ J}$       C  $1 \times 10^6 \text{ J}$       D  $1 \times 10^8 \text{ J}$

99 Three of these quantities have the same unit.

9702/13/O/N/12/Q4

Which quantity has a different unit?

- A  $\frac{\text{energy}}{\text{distance}}$
- B force
- C power  $\times$  time
- D rate of change of momentum



100 Which pair of quantities contains one vector and one scalar quantity?

9702/11/M/J/13/Q1

- A displacement; force
- B kinetic energy; power
- C acceleration; momentum
- D velocity; distance

101 One property  $Q$  of a material is used to describe the behaviour of sound waves in the material.  $Q$  is defined as the pressure  $P$  of the sound wave divided by the speed  $v$  of the wave and the surface area  $A$  of the material through which the wave travels:

9702/11/M/J/13/Q2

$$Q = \frac{P}{vA}$$

What are the SI base units of  $Q$ ?

- A  $\text{kg m}^2 \text{s}^{-3}$
- B  $\text{kg m}^{-3} \text{s}^{-1}$
- C  $\text{kg m}^{-4} \text{s}^{-1}$
- D  $\text{kg m}^{-2} \text{s}^{-2}$

102 Which pair includes a vector quantity and a scalar quantity?

9702/12/M/J/13/Q1

- A displacement; acceleration
- B force; kinetic energy
- C power; speed
- D work; potential energy

103 Two forces act on a circular disc as shown.

9702/12/M/J/13/Q3

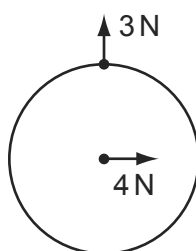

Which diagram shows the line of action of the resultant force?

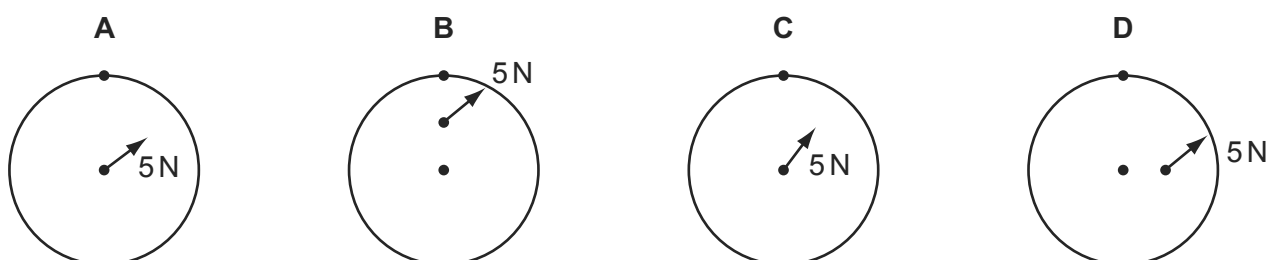

104 The unit of resistivity, expressed in terms of base units, is given by

9702/12/M/J/13/Q2

$$\text{kg x}^3 \text{y}^{-2} \text{z}^{-3}.$$

Which base units are x, y and z?

	x	y	z
<b>A</b>	ampere	metre	second
<b>B</b>	metre	ampere	second
<b>C</b>	metre	second	ampere
<b>D</b>	second	ampere	metre

105 The diagram shows a displacement vector.

9702/13/M/J/13/Q1

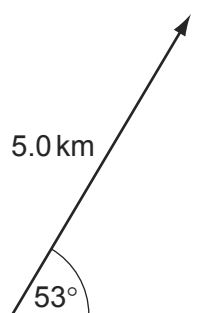

What is the vertical component of this displacement vector?

- A** 3.0 km      **B** 4.0 km      **C** 5.0 km      **D** 6.6 km

106 What is the unit of power, expressed in SI base units?

9702/13/M/J/13/Q2

- A**  $\text{kg m}^2 \text{s}^{-3}$       **B**  $\text{kg m s}^{-3}$       **C**  $\text{kg m s}^{-2}$       **D**  $\text{kg m}^2 \text{s}^{-1}$

107 Which statement is **incorrect** by a factor of 100 or more?

9702/13/M/J/13/Q3

- A** Atmospheric pressure is about  $1 \times 10^5$  Pa.  
**B** Light takes  $5 \times 10^2$  s to reach us from the Sun.  
**C** The frequency of ultra-violet light is  $3 \times 10^{12}$  Hz.  
**D** The life-span of a man is about  $2 \times 10^9$  s.

- 108 A cyclist is travelling due south with velocity  $u$ . The wind is blowing from the north-east with velocity  $w$ . 9702/13/M/J/13/Q4

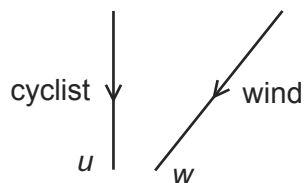

The wind has a velocity  $v$  relative to the cyclist, where  $v = w - u$ .

Which vector diagram shows the magnitude and direction of velocity  $v$ ?

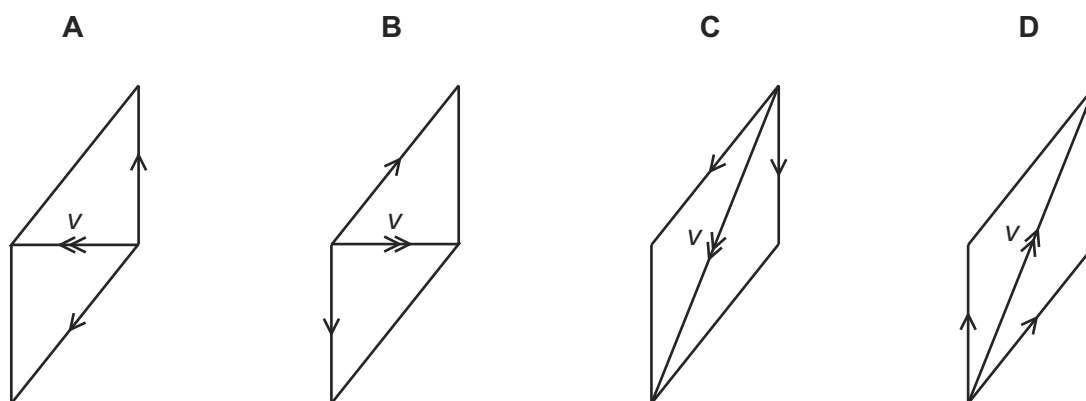

- 109 A pendulum bob is held stationary by a horizontal force  $H$ . The three forces acting on the bob are shown in the diagram. 9702/11/O/N/13/Q2

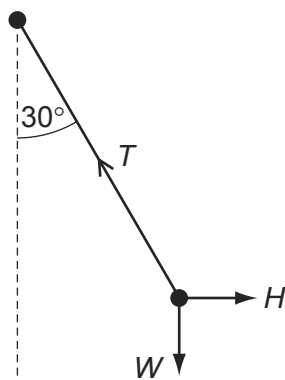

The tension in the string of the pendulum is  $T$ . The weight of the pendulum bob is  $W$ .

Which statement is correct?

- A  $H = T \cos 30^\circ$
- B  $T = H \sin 30^\circ$
- C  $W = T \cos 30^\circ$
- D  $W = T \sin 30^\circ$

110 Which row shows an SI base quantity with its correct unit?

9702/11/O/N/13/Q1

	SI base quantity	unit
<b>A</b>	charge	coulomb
<b>B</b>	current	ampere
<b>C</b>	potential difference	volt
<b>D</b>	temperature	degree Celsius

111 The drag coefficient  $C_d$  is a number with no units. It is used to compare the drag on different cars at different speeds. It is given by the equation

9702/11/O/N/13/Q3

$$C_d = \frac{2F}{\rho v^n A}$$

where  $F$  is the drag force on the car,  $\rho$  is the density of the air,  $A$  is the cross-sectional area of the car and  $v$  is the speed of the car.

What is the value of  $n$ ?

- A** 1                      **B** 2                      **C** 3                      **D** 4

112 Two forces of equal magnitude are represented by two coplanar vectors. One is directed eastwards and the other is directed northwards.

9702/13/O/N/13/Q3

What is the direction of a single force that will balance these two forces?

- A** towards the north-east  
**B** towards the north-west  
**C** towards the south-east  
**D** towards the south-west

113 The spring constant  $k$  of a coiled wire spring is given by the equation

9702/13/O/N/13/Q4

$$k = \frac{Gr^4}{4nR^3}$$

where  $r$  is the radius of the wire,  $n$  is the number of turns of wire and  $R$  is the radius of each of the turns of wire. The quantity  $G$  depends on the material from which the wire is made.

What is a suitable unit for  $G$ ?

- A**  $\text{Nm}^{-2}$                       **B**  $\text{Nm}^{-1}$                       **C**  $\text{Nm}$                       **D**  $\text{Nm}^2$

114 Which estimate is realistic?

9702/13/O/N/13/Q1

- A The kinetic energy of a bus travelling on an expressway is 30 000 J.
- B The power of a domestic light is 300 W.
- C The temperature of a hot oven is 300 K.
- D The volume of air in a car tyre is  $0.03\text{ m}^3$ .

115 Which unit is equivalent to the coulomb?

9702/13/O/N/13/Q2

- A ampere per second
- B joule per volt
- C watt per ampere
- D watt per volt

116 An archer draws his bowstring back to position X. The bowstring and arrow are shown. The tension  $T$  in the string is also shown. Then he draws the bowstring back further to position Y.

9702/11/O/N/13/Q14

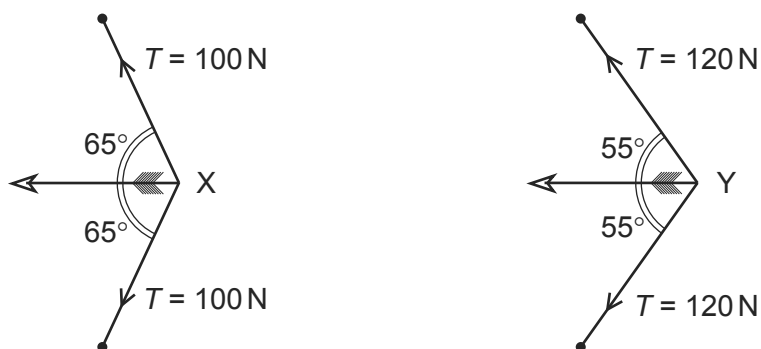

The resultant force on the arrow is greater when the arrow is released from position Y.

What is the increase in force?

- A 15 N
- B 27 N
- C 40 N
- D 53 N

117 The maximum theoretical power  $P$  of a wind turbine is given by the equation

9702/12/M/J/14/Q1

$$P = k\rho Av^n$$

where  $\rho$  is the density of air,  $A$  is the area swept by the turbine blades,  $v$  is the speed of the air and  $k$  is a constant with no units.

What is the value of  $n$ ?

- A 1
- B 2
- C 3
- D 4

- 118 Which pair of units contains one derived unit and one SI base unit? 9702/11/M/J/14/Q1
- A** ampere      coulomb
- B** kilogram      kelvin
- C** metre      second
- D** newton      pascal

- 119 What is equivalent to 2000 microvolts? 9702/11/M/J/14/Q2
- A**  $2\mu\text{JC}^{-1}$       **B** 2mV      **C** 2pV      **D** 2000mV

- 120 The speed  $v$  of a liquid leaving a tube depends on the change in pressure  $\Delta P$  and the density  $\rho$  of the liquid. The speed is given by the equation 9702/11/M/J/14/Q3

$$v = k \left( \frac{\Delta P}{\rho} \right)^n$$

where  $k$  is a constant that has no units.

What is the value of  $n$ ?

- A**  $\frac{1}{2}$       **B** 1      **C**  $\frac{3}{2}$       **D** 2
- 121 What is the unit of resistance when expressed in SI base units? 9702/12/M/J/14/Q2
- A**  $\text{kg m}^2 \text{s}^{-2} \text{A}^{-1}$
- B**  $\text{kg m}^2 \text{s}^{-3} \text{A}^{-2}$
- C**  $\text{kg m s}^{-2} \text{A}^{-1}$
- D**  $\text{kg m s}^{-3} \text{A}^{-1}$

- 122 Which quantity can be measured in electronvolts (eV)? 9702/13/M/J/14/Q1
- A** electric charge
- B** electric potential
- C** energy
- D** power

- 123 The unit of specific heat capacity is  $\text{J kg}^{-1} \text{K}^{-1}$ . 9702/13/M/J/14/Q2
- What is its equivalent in terms of SI base units?
- A**  $\text{kg}^{-1} \text{m}^2 \text{K}^{-1}$       **B**  $\text{ms}^{-1} \text{K}^{-1}$       **C**  $\text{ms}^{-2} \text{K}^{-1}$       **D**  $\text{m}^2 \text{s}^{-2} \text{K}^{-1}$

124 What is the vertical component of this displacement vector?

9702/13/M/J/14/Q3

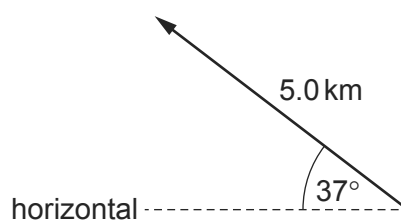

- A** 3.0 km      **B** 3.8 km      **C** 4.0 km      **D** 5.0 km

125 When the brakes are applied on a vehicle moving at speed  $v$ , the distance  $d$  moved by the vehicle in coming to rest is given by the expression

9702/13/O/N/14/Q1

$$d = kv^2$$

where  $k$  is a constant.

What is the unit of  $k$  expressed in SI base units?

- A**  $\text{m}^{-1}\text{s}^2$       **B**  $\text{ms}^{-2}$       **C**  $\text{m}^2\text{s}^{-2}$       **D**  $\text{m}^{-1}\text{s}$

126 Which list contains one vector quantity and two scalar quantities?

9702/13/O/N/14/Q2

- A** displacement, weight, velocity  
**B** force, acceleration, time  
**C** momentum, mass, speed  
**D** work, density, energy

127 What is equivalent to the unit of electric field strength?

9702/11/O/N/14/Q2

- A**  $\text{JCm}^{-1}$       **B**  $\text{NsA}^{-1}$       **C**  $\text{kgms}^{-3}\text{A}^{-1}$       **D**  $\text{kgm}^3\text{s}^{-3}\text{A}^{-1}$

128 Which statement includes a correct unit?

9702/13/M/J/15/Q1

- A** energy = 7.8 N s  
**B** force = 3.8 N s  
**C** momentum = 6.2 N s  
**D** torque = 4.7 N s

129 What is the joule (J) in SI base units?

9702/13/M/J/15/Q2

- A**  $\text{kgms}^{-1}$       **B**  $\text{kgm}^2\text{s}^{-1}$       **C**  $\text{kgms}^{-2}$       **D**  $\text{kgm}^2\text{s}^{-2}$

130 The diagram shows the reading on an analogue ammeter.

9702/11/O/N/14/Q3

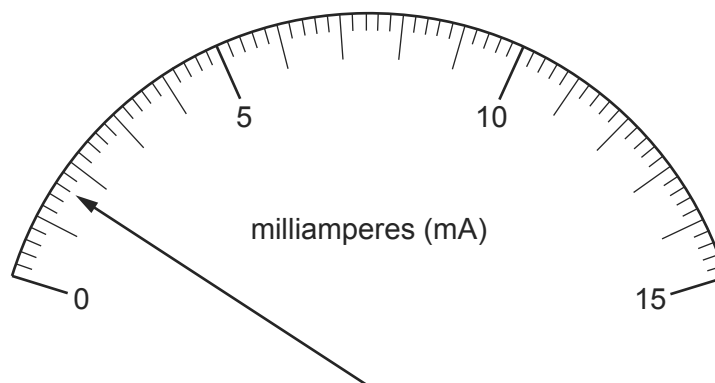

Which digital ammeter reading is the same as the reading on the analogue ammeter?

	display units	display reading
<b>A</b>	$\mu\text{A}$	1600
<b>B</b>	$\mu\text{A}$	160
<b>C</b>	mA	16.0
<b>D</b>	A	1.60

131 Which definition is correct and uses only quantities rather than units?

9702/12/M/J/15/Q1

- A** Density is mass per cubic metre.
- B** Potential difference is energy per unit current.
- C** Pressure is force per unit area.
- D** Speed is distance travelled per second.

132 The average kinetic energy  $E$  of a gas molecule is given by the equation

9702/12/M/J/15/Q2

$$E = \frac{3}{2} kT$$

where  $T$  is the absolute (kelvin) temperature.

What are the SI base units of  $k$ ?

- A**  $\text{kg}^{-1} \text{m}^{-1} \text{s}^2 \text{K}$
- B**  $\text{kg}^{-1} \text{m}^{-2} \text{s}^2 \text{K}$
- C**  $\text{kg m s}^{-2} \text{K}^{-1}$
- D**  $\text{kg m}^2 \text{s}^{-2} \text{K}^{-1}$



133 Which is an SI base unit?

9702/11/M/J/15/Q1

- A current
- B gram
- C kelvin
- D volt

134 Which pair contains one vector and one scalar quantity?

9702/11/M/J/15/Q2

- A displacement      acceleration
- B force              kinetic energy
- C momentum        velocity
- D power              speed

135 When a constant braking force is applied to a vehicle moving at speed  $v$ , the distance  $d$  moved by the vehicle in coming to rest is given by the expression

9702/11/M/J/15/Q3

$$d = kv^2$$

where  $k$  is a constant.

When  $d$  is measured in metres and  $v$  is measured in metres per second, the constant has a value of  $k_1$ .

What is the value of the constant when the distance is measured in metres, and the speed is measured in kilometres per hour?

- A  $0.0772 k_1$       B  $0.278 k_1$       C  $3.60 k_1$       D  $13.0 k_1$

- 4 A student measures the time  $t$  for a ball to fall from rest through a vertical distance  $h$ . Knowing that the equation  $h = \frac{1}{2}gt^2$  applies, the student plots the graph shown.

9702/1/M/J/02

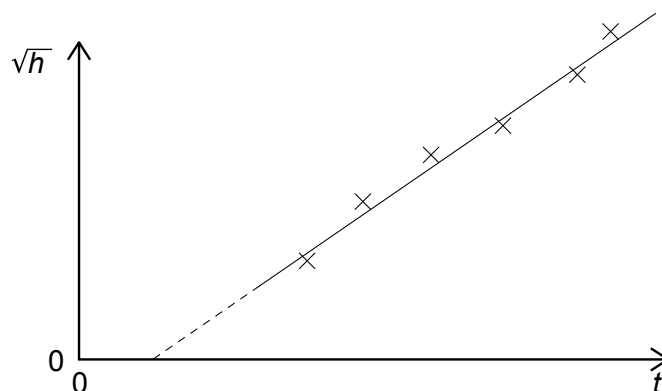

Which of the following is an explanation for the intercept on the  $t$  axis?

- A Air resistance has not been taken into account for larger values of  $h$ .
- B There is a constant delay between starting the timer and releasing the ball.
- C There is an error in the timer that consistently makes it run fast.
- D The student should have plotted  $h$  against  $t^2$ .
- 5 A student carries out a series of determinations of the acceleration of free fall  $g$ . The table shows the results.

9702/1/O/N/02

$g/\text{ms}^{-2}$
4.91
4.89
4.88
4.90
4.93
4.92

What can be said about this experiment?

- A It is accurate and precise.
- B It is accurate but not precise.
- C It is not accurate and not precise.
- D It is not accurate but is precise.

- 5 The power loss  $P$  in a resistor is calculated using the formula  $P = V^2/R$ . 9702/1/M/J/02

The uncertainty in the potential difference  $V$  is 3% and the uncertainty in the resistance  $R$  is 2%.

What is the uncertainty in  $P$ ?

- A** 4%      **B** 7%      **C** 8%      **D** 11%

- 4 Which experimental technique reduces the systematic error of the quantity being investigated? 9702/01/M/J/03

- A** adjusting an ammeter to remove its zero error before measuring a current  
**B** measuring several internodal distances on a standing wave to find the mean internodal distance  
**C** measuring the diameter of a wire repeatedly and calculating the average  
**D** timing a large number of oscillations to find a period

- 5 A student makes measurements from which she calculates the speed of sound as  $327.66 \text{ m s}^{-1}$ . She estimates that her result is accurate to  $\pm 3\%$ . 9702/01/M/J/03

Which of the following gives her result expressed to the appropriate number of significant figures?

- A**  $327.7 \text{ m s}^{-1}$       **B**  $328 \text{ m s}^{-1}$       **C**  $330 \text{ m s}^{-1}$       **D**  $300 \text{ m s}^{-1}$

- 7 A projectile is fired at an angle  $\alpha$  to the horizontal at a speed  $u$ , as shown. 9702/01/M/J/03

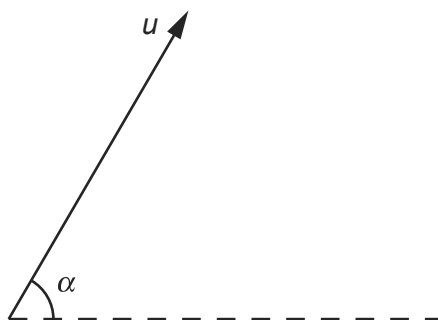

What will be the vertical and horizontal components of its velocity after a time  $t$ ? Assume that air resistance is negligible. The acceleration of free fall is  $g$ .

	vertical component	horizontal component
<b>A</b>	$u \sin \alpha$	$u \cos \alpha$
<b>B</b>	$u \sin \alpha - gt$	$u \cos \alpha - gt$
<b>C</b>	$u \sin \alpha - gt$	$u \cos \alpha$
<b>D</b>	$u \cos \alpha$	$u \sin \alpha - gt$

- 6 A quantity  $X$  is measured many times. A graph is plotted showing the number  $n$  of times a particular value of  $X$  is obtained.  $X$  has a true value  $X_0$ .

9702/1/O/N/02

Which graph could be obtained if the measurement of  $X$  has a large systematic error but a small random error?

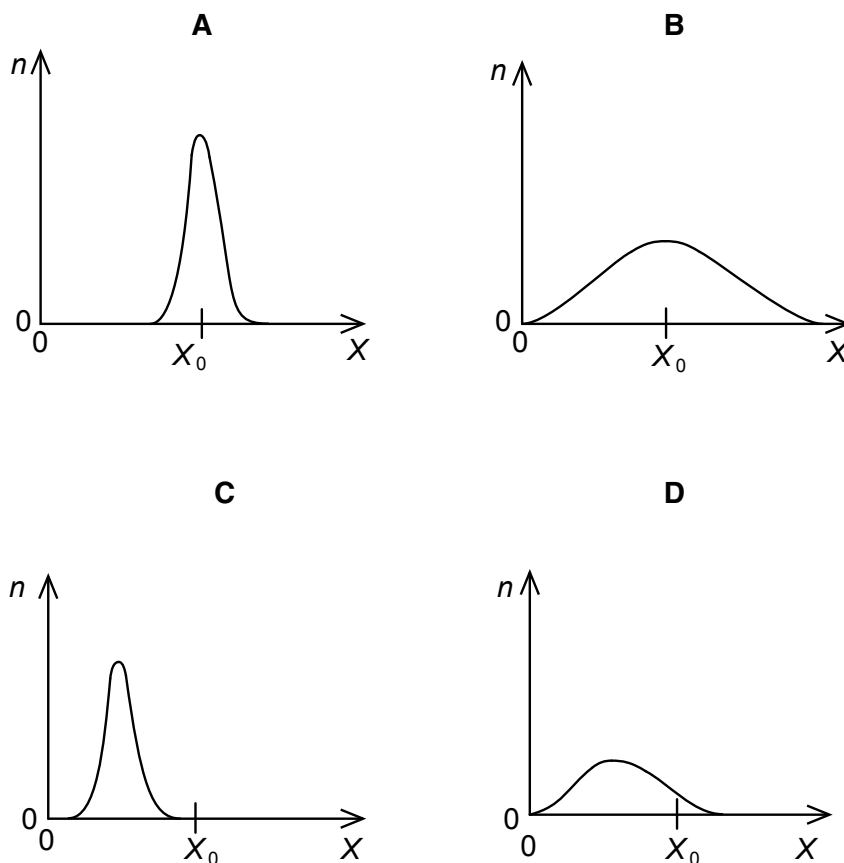

- 7 The diagram shows a square-wave trace on the screen of a cathode-ray oscilloscope. A grid of 1 cm squares covers the screen. The time-base setting is  $10 \text{ ms cm}^{-1}$ .

9702/1/O/N/02

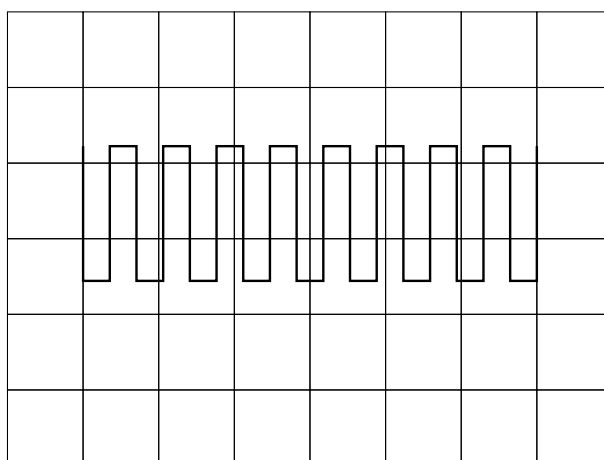

What is the approximate frequency of the square-wave?

- A** 70 Hz      **B** 140 Hz      **C** 280 Hz      **D** 1400 Hz

- 6 A steel rule can be read to the nearest millimetre. It is used to measure the length of a bar whose true length is 895 mm. Repeated measurements give the following readings.

9702/01/M/J/03

length / mm	892, 891, 892, 891, 891, 892
-------------	------------------------------

Are the readings accurate and precise to within 1 mm?

	results are accurate to within 1 mm	results are precise to within 1 mm
<b>A</b>	no	no
<b>B</b>	no	yes
<b>C</b>	yes	no
<b>D</b>	yes	yes

- 4 A thermometer can be read to an accuracy of  $\pm 0.5^\circ\text{C}$ . This thermometer is used to measure a temperature rise from  $40^\circ\text{C}$  to  $100^\circ\text{C}$ .

9702/01/O/N/03

What is the percentage uncertainty in the measurement of the temperature rise?

- A** 0.5%      **B** 0.8%      **C** 1.3%      **D** 1.7%

- 4 What is the reading shown on this milliammeter?

9702/01/M/J/04

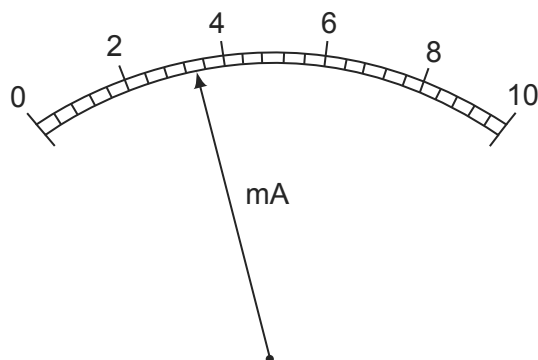

- A** 2.35 mA      **B** 2.7 mA      **C** 3.4 mA      **D** 3.7 mA

- 4 In an experiment, a radio-controlled car takes  $2.50 \pm 0.05\text{ s}$  to travel  $40.0 \pm 0.1\text{ m}$ .

9702/01/M/J/05

What is the car's average speed and the uncertainty in this value?

- A**  $16 \pm 1\text{ m s}^{-1}$   
**B**  $16.0 \pm 0.2\text{ m s}^{-1}$   
**C**  $16.0 \pm 0.4\text{ m s}^{-1}$   
**D**  $16.00 \pm 0.36\text{ m s}^{-1}$

- 5 The time-base on a cathode-ray oscilloscope is set at 6 ms/cm.

A trace consisting of two pulses is recorded as shown in the diagram.

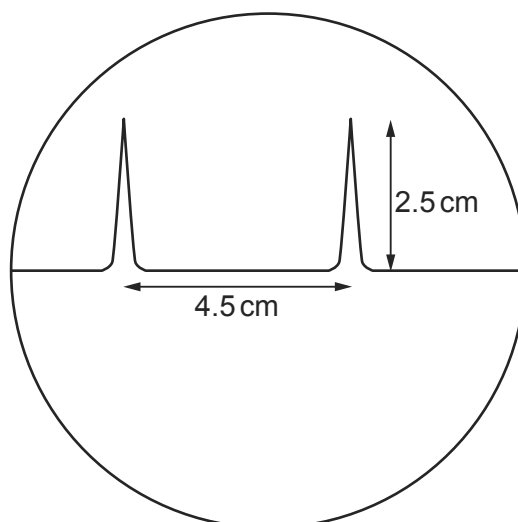

What is the time interval between the two pulses?

- A** 0.42 ms      **B** 0.75 ms      **C** 1.33 ms      **D** 27 ms
- 6 A micrometer screw gauge is used to measure the diameter of a copper wire.

The reading with the wire in position is shown in diagram 1. The wire is removed and the jaws of the micrometer are closed. The new reading is shown in diagram 2.

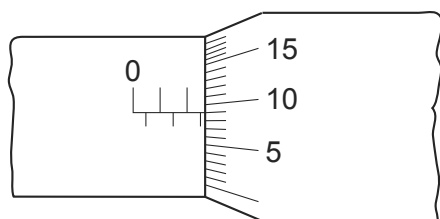

diagram 1

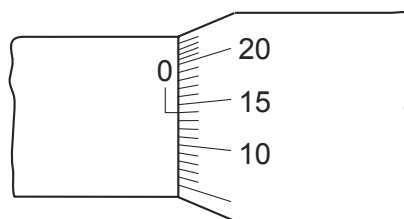

diagram 2

What is the diameter of the wire?

- A** 1.90 mm      **B** 2.45 mm      **C** 2.59 mm      **D** 2.73 mm
- 6 The resistance  $R$  of an unknown resistor is found by measuring the potential difference  $V$  across the resistor and the current  $I$  through it and using the equation  $R = \frac{V}{I}$ . The voltmeter reading has a 3% uncertainty and the ammeter reading has a 2% uncertainty.

What is the uncertainty in the calculated resistance?

- A** 1.5%      **B** 3%      **C** 5%      **D** 6%

- 5 The following trace is seen on the screen of a cathode-ray oscilloscope.

9702/01/M/J/04

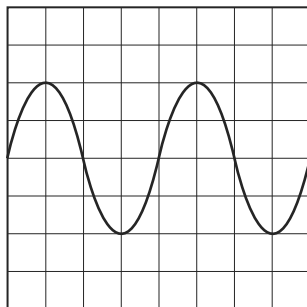

The setting of the time base is then changed from  $10 \text{ ms cm}^{-1}$  to  $20 \text{ ms cm}^{-1}$  and the Y-sensitivity is unaltered.

Which trace is now seen on the screen?

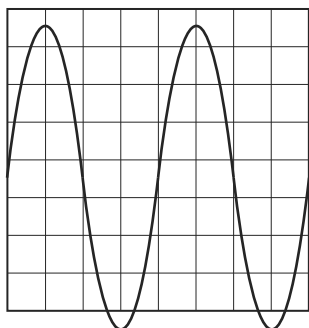
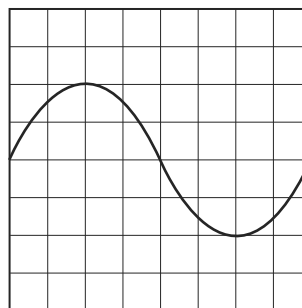
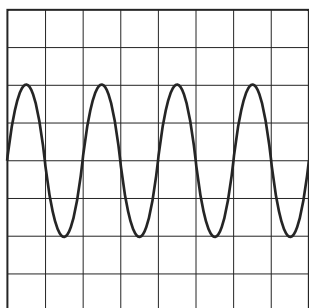
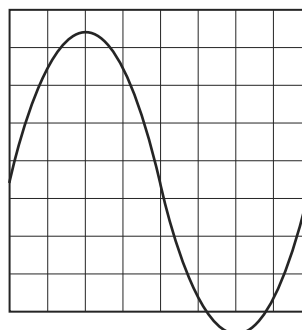
**A****B****C****D**

- 6 Four students each made a series of measurements of the acceleration of free fall  $g$ . The table shows the results obtained.

9702/01/O/N/04

Which student obtained a set of results that could be described as precise but not accurate?

student	results, $g / \text{m s}^{-2}$			
<b>A</b>	9.81	9.79	9.84	9.83
<b>B</b>	9.81	10.12	9.89	8.94
<b>C</b>	9.45	9.21	8.99	8.76
<b>D</b>	8.45	8.46	8.50	8.41

- 4 The deflection of the needle of an ammeter varies with the current passing through the ammeter as shown in the graph.

9702/01/O/N/04

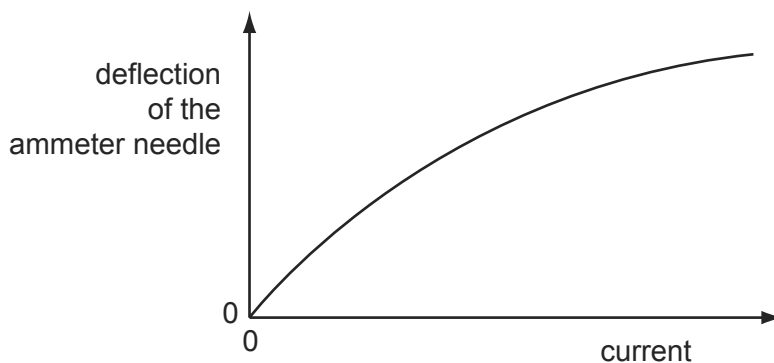

Which diagram could represent the appearance of the scale of this meter?

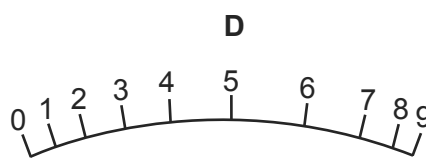
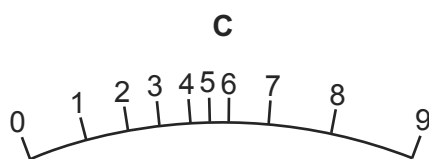
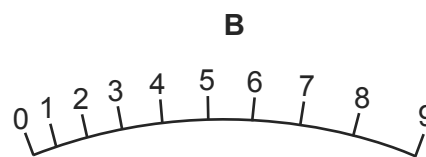
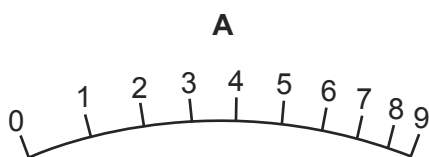

- 5 The diagram shows two pulses on the screen of a cathode ray oscilloscope. A grid of 1 cm squares covers the screen. The time base setting is  $1 \mu\text{s cm}^{-1}$ .

9702/01/M/J/05

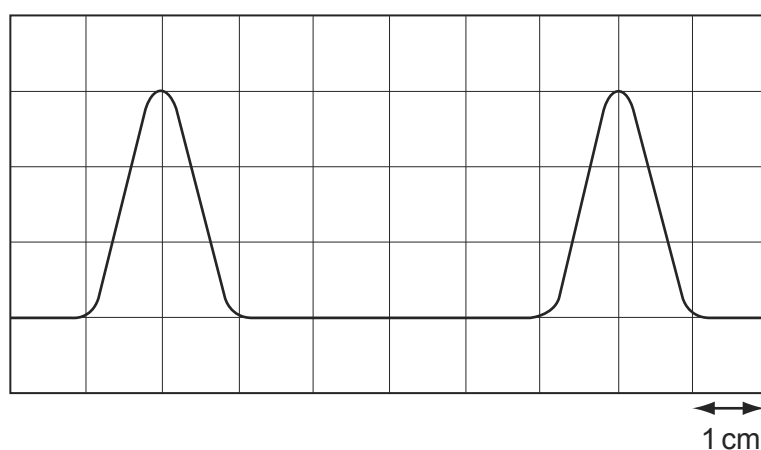

How long does each pulse last?

- A**  $2 \mu\text{s}$       **B**  $3 \mu\text{s}$       **C**  $4 \mu\text{s}$       **D**  $6 \mu\text{s}$



- 5 When a 12 V 50 Hz supply is connected to the Y-terminals of an oscilloscope, the trace in the diagram is obtained.

9702/01/O/N/04

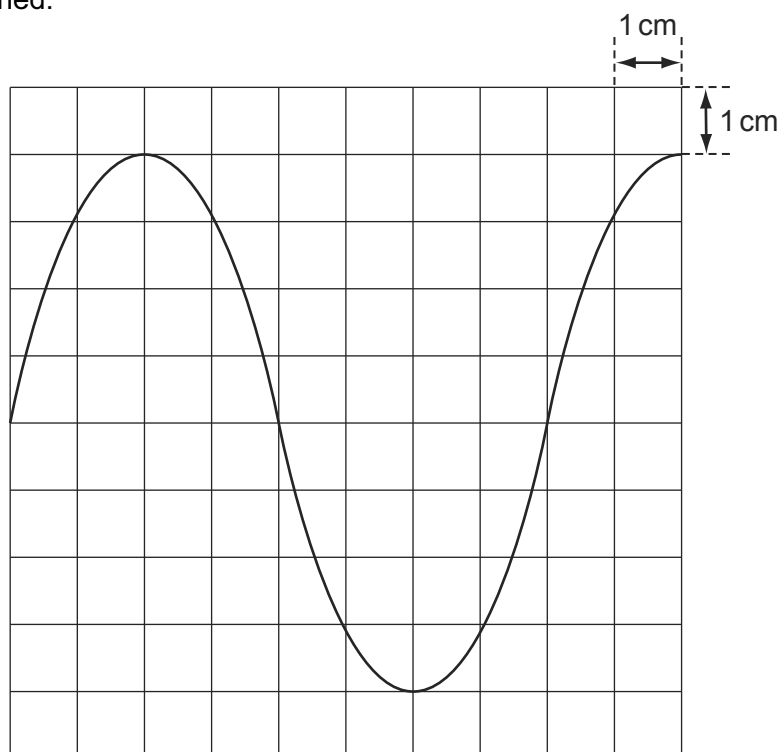

What is the setting of the time-base control?

- A**  $2.0 \text{ ms cm}^{-1}$     **B**  $2.5 \text{ ms cm}^{-1}$     **C**  $5 \text{ ms cm}^{-1}$     **D**  $20 \text{ ms cm}^{-1}$
- 4 A steel rule can be read to the nearest millimetre. It is used to measure the length of a bar whose true length is 895 mm. Repeated measurements give the following readings.

9702/01/O/N/05

length/mm    892, 891, 892, 891, 891, 892

Are the readings accurate and precise to within 1 mm?

	results are accurate to within 1 mm	results are precise to within 1 mm
<b>A</b>	no	no
<b>B</b>	no	yes
<b>C</b>	yes	no
<b>D</b>	yes	yes

- 6 In a simple electrical circuit, the current in a resistor is measured as  $(2.50 \pm 0.05) \text{ mA}$ . The resistor is marked as having a value of  $4.7 \Omega \pm 2\%$ .

9702/01/M/J/04

If these values were used to calculate the power dissipated in the resistor, what would be the percentage uncertainty in the value obtained?

- A** 2%    **B** 4%    **C** 6%    **D** 8%

- 5 The density of the material of a rectangular block is determined by measuring the mass and linear dimensions of the block. The table shows the results obtained, together with their uncertainties.

9702/01/O/N/05

mass	=	$(25.0 \pm 0.1)\text{g}$
length	=	$(5.00 \pm 0.01)\text{cm}$
breadth	=	$(2.00 \pm 0.01)\text{cm}$
height	=	$(1.00 \pm 0.01)\text{cm}$

The density is calculated to be  $2.50\text{g cm}^{-3}$ .

What is the uncertainty in this result?

- A  $\pm 0.01\text{g cm}^{-3}$     B  $\pm 0.02\text{g cm}^{-3}$     C  $\pm 0.05\text{g cm}^{-3}$     D  $\pm 0.13\text{g cm}^{-3}$
- 6 A football is dropped from the top of a tall building.

9702/01/O/N/05

Which acceleration-time graph best represents the motion of the football through the air?

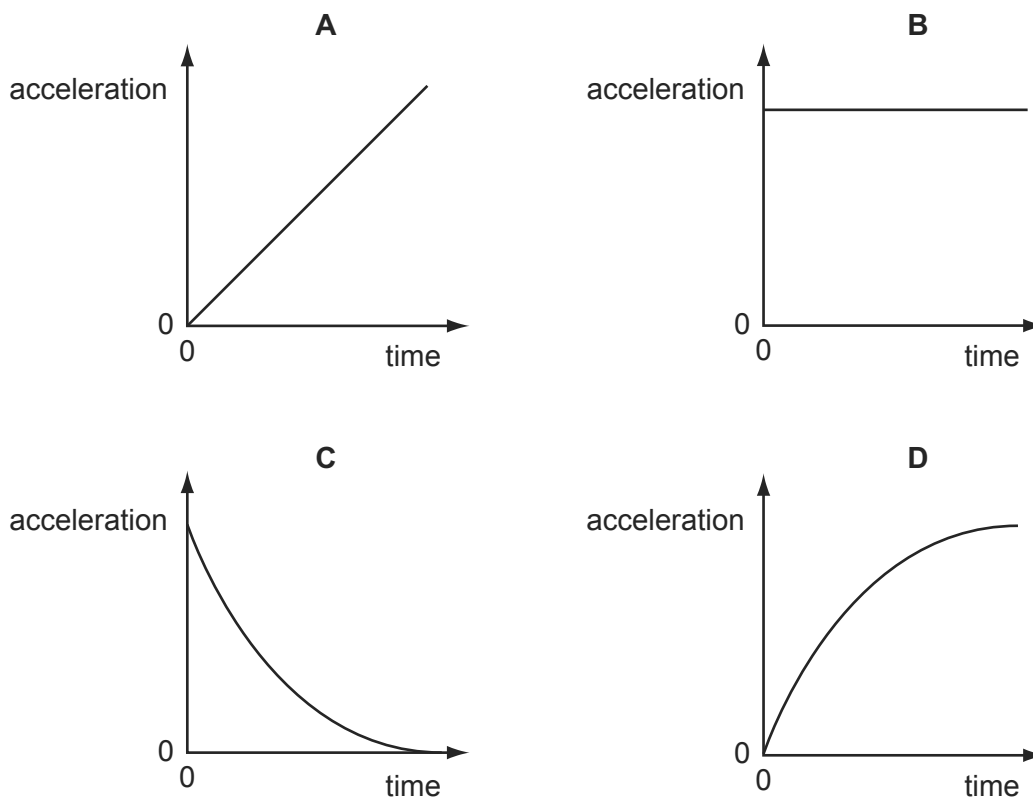

- 4 A metre rule is used to measure the length of a piece of wire. It is found to be 70 cm long to the nearest millimetre.

9702/12/O/N/10

How should this result be recorded in a table of results?

- A 0.7 m    B 0.70 m    C 0.700 m    D 0.7000 m

- 4 A light meter measures the intensity  $I$  of the light falling on it. Theory suggests that this varies as the inverse square of the distance  $d$ .

9702/01/M/J/06

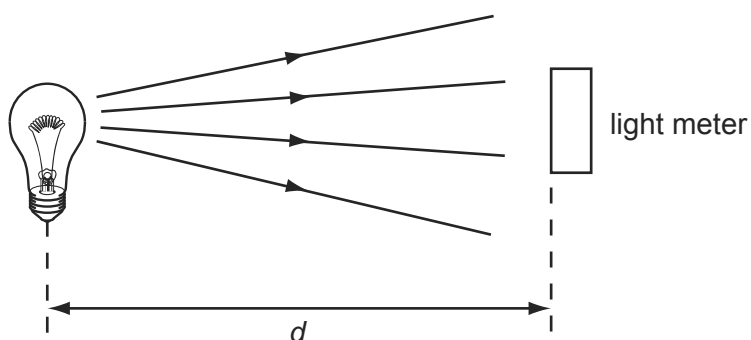

Which graph of the results supports this theory?

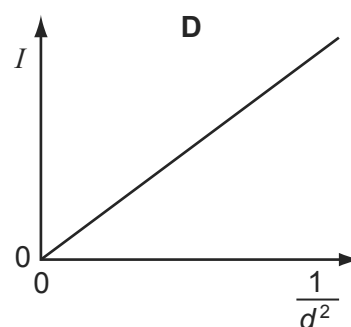
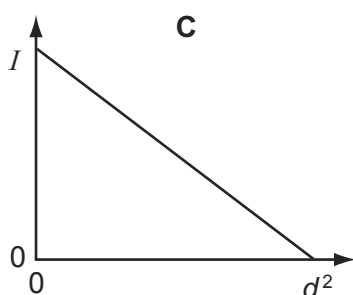
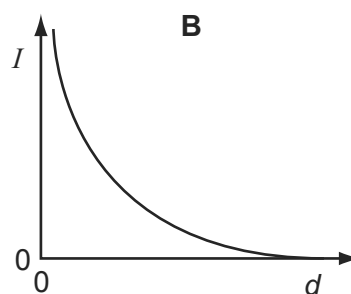
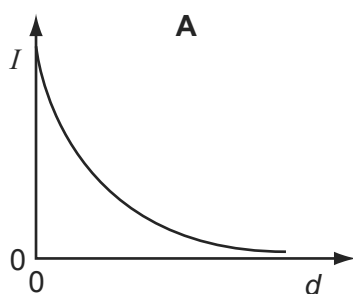

- 5 The resistance of an electrical component is measured. The following meter readings are obtained.

9702/01/M/J/07

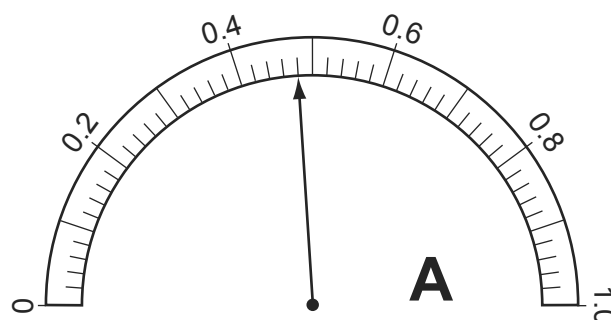

What is the resistance?

- A**  $2.5\ \Omega$       **B**  $2.7\ \Omega$       **C**  $2500\ \Omega$       **D**  $2700\ \Omega$

- 5 The cathode-ray oscilloscope (c.r.o.) display shows the waveform produced by an electronic circuit. The c.r.o. time-base is set at 10 ms per division.

9702/01/M/J/06

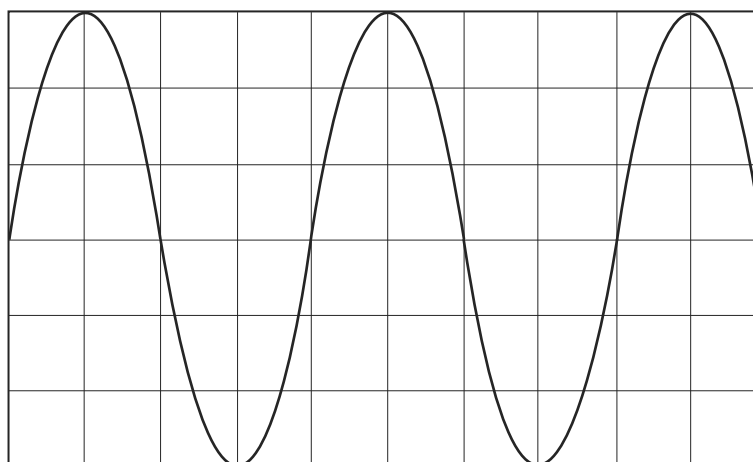

What is the period of the signal shown?

- A** 20 ms      **B** 30 ms      **C** 40 ms      **D** 80 ms

- 4 A series of measurements of the acceleration of free fall  $g$  is shown in the table.

9702/01/O/N/07

Which set of results is precise but not accurate?

	$g/\text{ms}^{-2}$				
<b>A</b>	9.81	9.79	9.84	9.83	9.79
<b>B</b>	9.81	10.12	9.89	8.94	9.42
<b>C</b>	9.45	9.21	8.99	8.76	8.51
<b>D</b>	8.45	8.46	8.50	8.41	8.47

- 5 A mass  $m$  has acceleration  $a$ . It moves through a distance  $s$  in time  $t$ . The power used in accelerating the mass is equal to the product of force and velocity. The percentage uncertainties are

9702/01/O/N/07

0.1% in  $m$ ,

1% in  $a$ ,

1.5% in  $s$ ,

0.5% in  $t$ .

What is the percentage uncertainty in the average power?

- A** 2.1%      **B** 2.6%      **C** 3.1%      **D** 4.1%

- 4 The Y-input terminals of a cathode-ray oscilloscope (c.r.o.) are connected to a supply of peak value 5.0 V and of frequency 50 Hz. The time-base is set at 10 ms per division and the Y-gain at 5.0 V per division.

9702/01/O/N/06

Which trace is obtained?

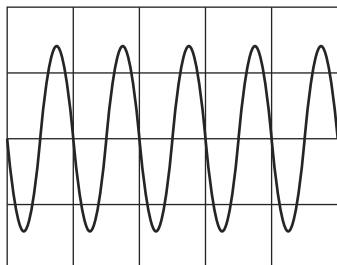
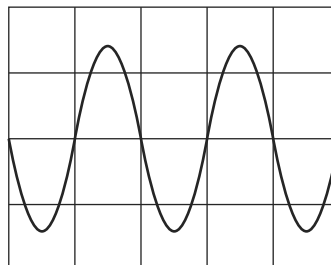
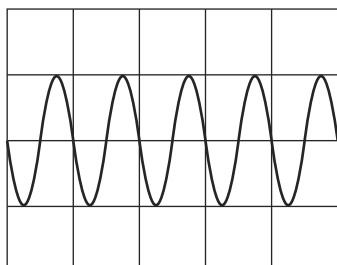
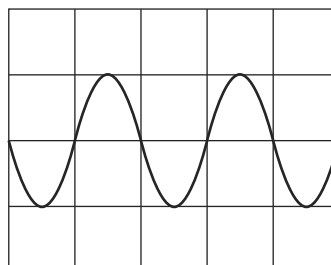
**A****B****C****D**

- 5 The measurement of a physical quantity may be subject to random errors and to systematic errors.

9702/01/O/N/06

Which statement is correct?

- A** Random errors can be reduced by taking the average of several measurements.
- B** Random errors are always caused by the person taking the measurement.
- C** A systematic error cannot be reduced.
- D** A systematic error results in a different reading each time the measurement is taken.
- 6 An experiment is done to measure the resistance of a wire.

9702/01/O/N/06

The current in the wire is  $1.0 \pm 0.2$  A and the potential difference across the wire is  $8.0 \pm 0.4$  V.

What is the resistance of the wire and its uncertainty?

- A**  $(8.0 \pm 0.2) \Omega$
- B**  $(8.0 \pm 0.6) \Omega$
- C**  $(8 \pm 1) \Omega$
- D**  $(8 \pm 2) \Omega$

- 4 An oscilloscope display consists of two separate traces, a waveform and a long horizontal line. The horizontal line may be taken as the zero level.

9702/01/M/J/07

The grid on the screen is calibrated in cm squares, the timebase setting is  $2.5 \text{ ms cm}^{-1}$ , and the Y-sensitivity is  $5 \text{ mV cm}^{-1}$ .

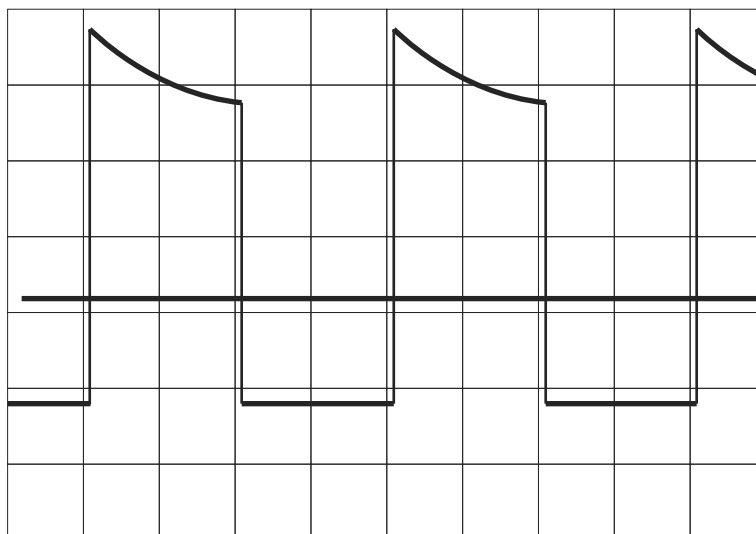

What are the period and the peak positive voltage of the waveform in the diagram?

	period / ms	peak positive voltage / mV
<b>A</b>	5	17
<b>B</b>	5	25
<b>C</b>	10	17
<b>D</b>	10	25

- 4 The resistance  $R$  of a resistor is determined by measuring the potential difference  $V$  across it and the current  $I$  in it. The value of  $R$  is then calculated using the equation

9702/01/M/J/08

$$R = \frac{V}{I}.$$

The values measured are  $V = 1.00 \pm 0.05 \text{ V}$  and  $I = 0.50 \pm 0.01 \text{ A}$ .

What is the percentage uncertainty in the value of  $R$ ?

- A** 2.5%      **B** 3.0%      **C** 7.0%      **D** 10.0%

- 6 The diagram shows the graduations of a correctly calibrated ammeter. When the current is zero, the pointer is at 0.

9702/01/O/N/07

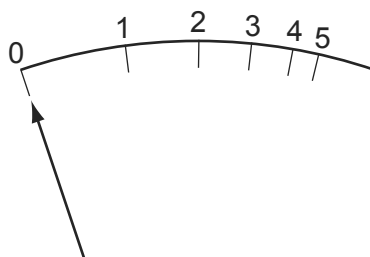

The ammeter is accidentally readjusted so that when the current is zero, the pointer is at X.

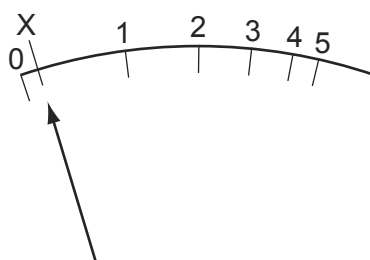

Which calibration graph best represents the response of the readjusted ammeter?

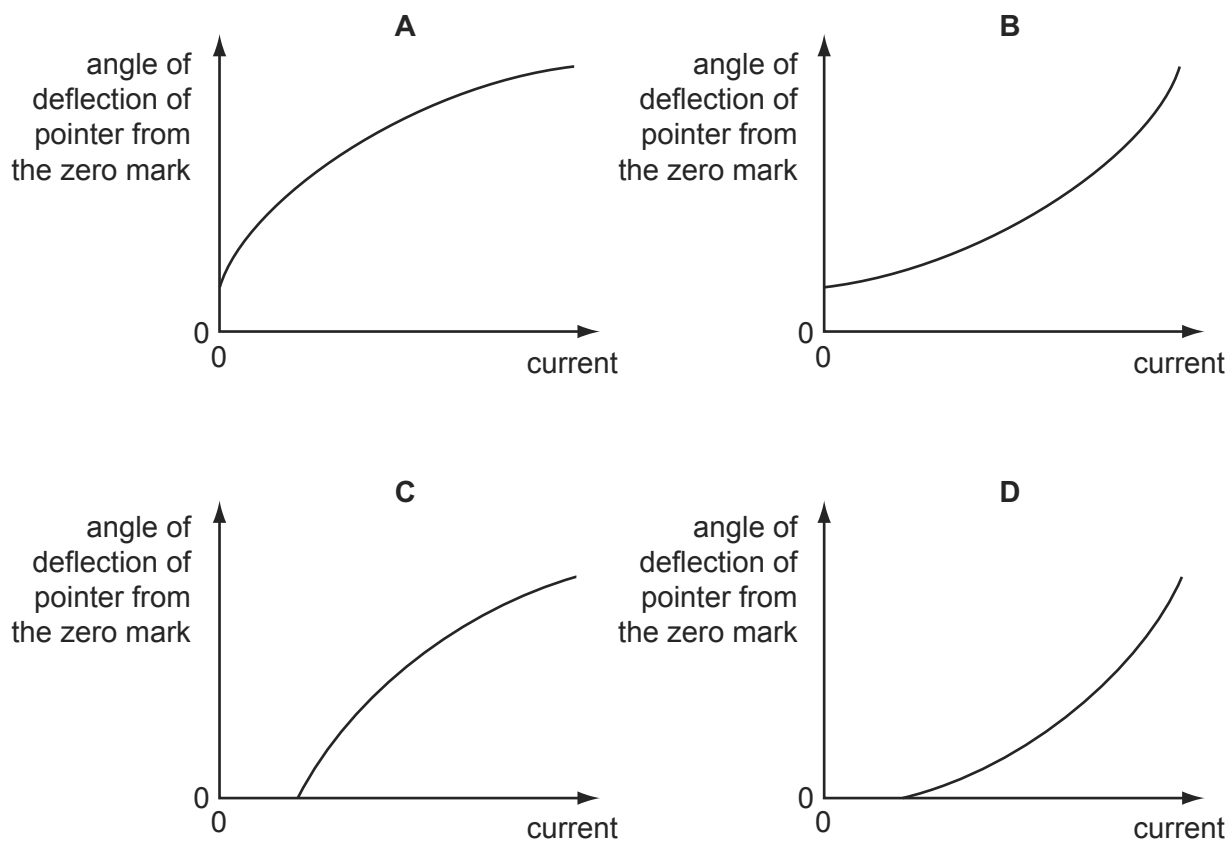

- 5 Four students each made a series of measurements of the acceleration of free fall  $g$ . The table shows the results obtained.

9702/01/M/J/08

Which set of results could be described as precise but **not** accurate?

	$g/\text{ms}^{-2}$			
<b>A</b>	9.81	9.79	9.84	9.83
<b>B</b>	9.81	10.12	9.89	8.94
<b>C</b>	9.45	9.21	8.99	8.76
<b>D</b>	8.45	8.46	8.50	8.41

- 4 A student uses a digital ammeter to measure a current. The reading of the ammeter is found to fluctuate between 1.98 A and 2.02 A.

9702/01/O/N/08

The manufacturer of the ammeter states that any reading has a systematic uncertainty of  $\pm 1\%$ .

Which value of current should be quoted by the student?

- A**  $(2.00 \pm 0.01)\text{A}$   
**B**  $(2.00 \pm 0.02)\text{A}$   
**C**  $(2.00 \pm 0.03)\text{A}$   
**D**  $(2.00 \pm 0.04)\text{A}$
- 5 A calibration graph is produced for a faulty ammeter.

9702/01/O/N/08

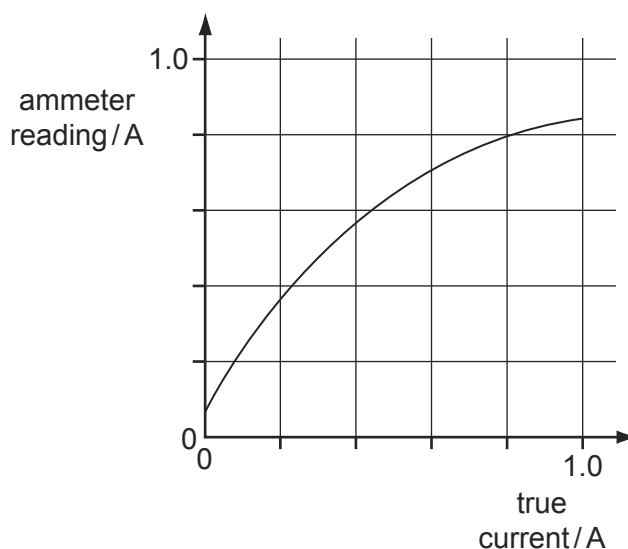

Which ammeter reading will be nearest to the correct value?

- A** 0.2 A      **B** 0.4 A      **C** 0.6 A      **D** 0.8 A



- 3 The diagram shows the stem of a Celsius thermometer marked to show initial and final temperature values.

9702/01/M/J/09

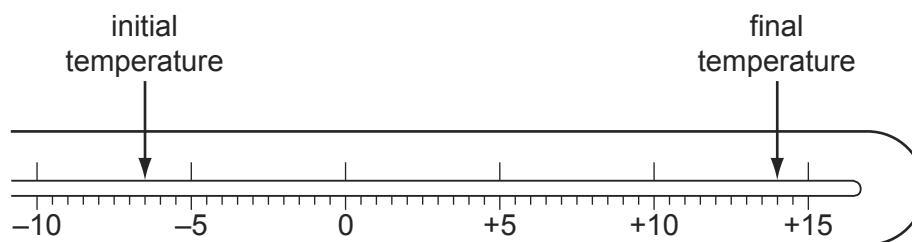

What is the temperature change expressed to an appropriate number of significant figures?

- A 14 °C      B 20.5 °C      C 21 °C      D 22.0 °C
- 4 The diagrams show digital voltmeter and analogue ammeter readings from a circuit in which electrical heating is occurring.

9702/01/M/J/09

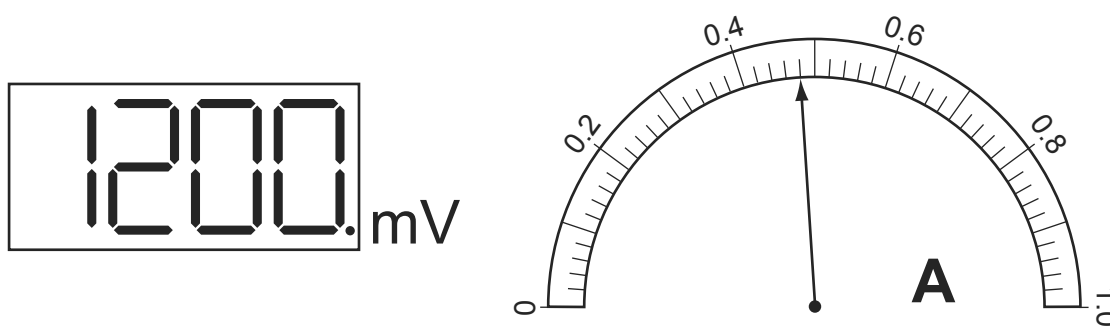

What is the electrical power of the heater?

- A 0.53 W      B 0.58 W      C 530 W      D 580 W
- 3 The graph shows two current-voltage calibration curves for a solar cell exposed to different light intensities.

9702/11/O/N/09

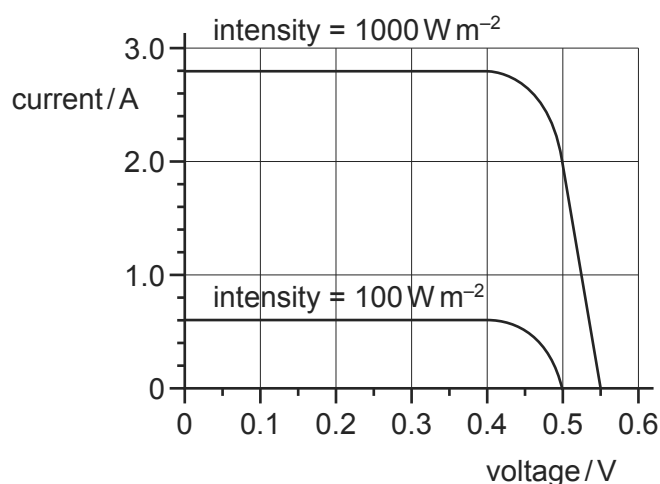

At zero voltage, what is the ratio  $\frac{\text{current at } 1000 \text{ W m}^{-2}}{\text{current at } 100 \text{ W m}^{-2}}$  ?

- A 1.1      B 4.7      C 8.0      D 10

- 4 The diagram shows an oscilloscope screen displaying two signals.

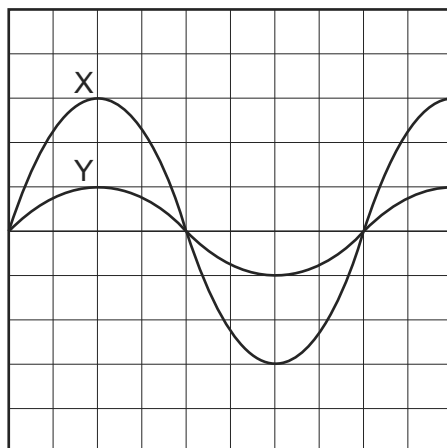

Signal X has a frequency of 50 Hz and peak voltage of 12 V.

What is the period and peak voltage of signal Y?

	period / ms	peak voltage / V
<b>A</b>	20	4
<b>B</b>	20	12
<b>C</b>	50	4
<b>D</b>	50	12

- 2 The graph shows two current-voltage calibration curves for a solar cell exposed to different light intensities.

9702/12/O/N/09

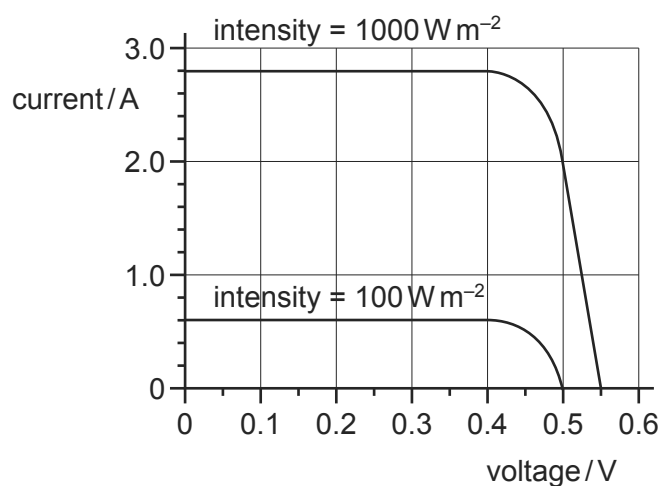

At zero voltage, what is the ratio  $\frac{\text{current at } 1000 \text{ W m}^{-2}}{\text{current at } 100 \text{ W m}^{-2}}$  ?

- A** 1.1      **B** 4.7      **C** 8.0      **D** 10

- 3 The diagram shows an oscilloscope screen displaying two signals.

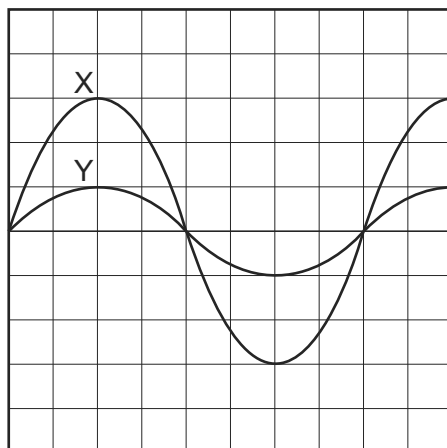

Signal X has a frequency of 50 Hz and peak voltage of 12 V.

What is the period and peak voltage of signal Y?

	period / ms	peak voltage / V
<b>A</b>	20	4
<b>B</b>	20	12
<b>C</b>	50	4
<b>D</b>	50	12

- 4 The diagram shows a square-wave trace on the screen of a cathode-ray oscilloscope. A grid of 1 cm squares covers the screen. The time-base setting is  $10 \text{ ms cm}^{-1}$ .

9702/11/M/J/10

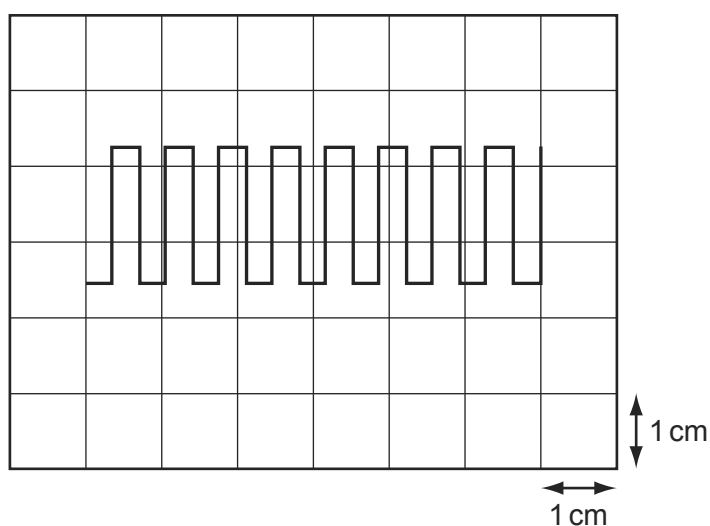

What is the approximate frequency of the square wave?

- A** 70 Hz      **B** 140 Hz      **C** 280 Hz      **D** 1400 Hz

- 6 A student finds the density of a liquid by measuring its mass and its volume. The following is a summary of his measurements.

9702/11/M/J/10

$$\text{mass of empty beaker} = (20 \pm 1)\text{g}$$

$$\text{mass of beaker + liquid} = (70 \pm 1)\text{g}$$

$$\text{volume of liquid} = (10.0 \pm 0.6)\text{cm}^3$$

He correctly calculates the density of the liquid as  $5.0\text{g cm}^{-3}$ .

What is the uncertainty in this value?

- A  $0.3\text{g cm}^{-3}$     B  $0.5\text{g cm}^{-3}$     C  $0.6\text{g cm}^{-3}$     D  $2.6\text{g cm}^{-3}$
- 7 A micrometer screw gauge is used to measure the diameter of a copper wire.

The reading with the wire in position is shown in diagram 1. The wire is removed and the jaws of the micrometer are closed. The new reading is shown in diagram 2.

9702/11/M/J/10

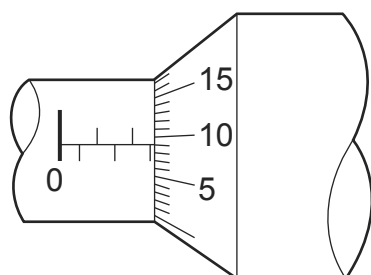

diagram 1

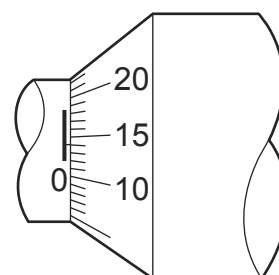

diagram 2

What is the diameter of the wire?

- A 1.90 mm    B 2.45 mm    C 2.59 mm    D 2.73 mm
- 1 A micrometer screw gauge is used to measure the diameter of a copper wire.

9702/12/M/J/10

The reading with the wire in position is shown in diagram 1. The wire is removed and the jaws of the micrometer are closed. The new reading is shown in diagram 2.

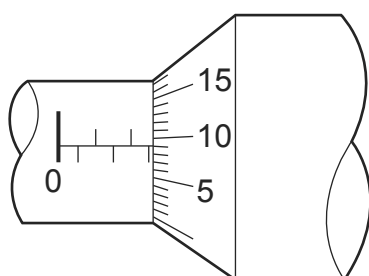

diagram 1

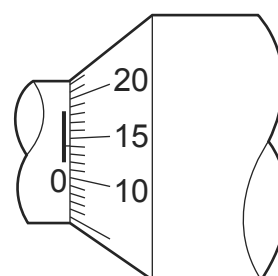

diagram 2

What is the diameter of the wire?

- A 1.90 mm    B 2.45 mm    C 2.59 mm    D 2.73 mm

- 5 The diagram shows a square-wave trace on the screen of a cathode-ray oscilloscope. A grid of 1 cm squares covers the screen. The time-base setting is  $10 \text{ ms cm}^{-1}$ .

9702/12/M/J/10

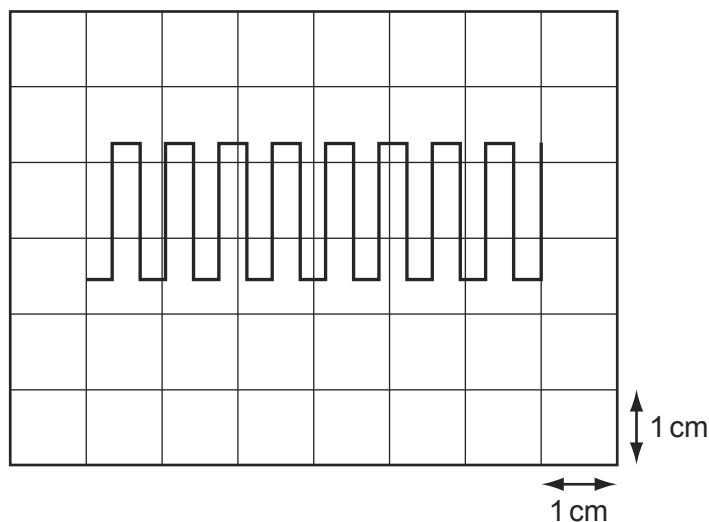

What is the approximate frequency of the square wave?

- A** 70 Hz      **B** 140 Hz      **C** 280 Hz      **D** 1400 Hz
- 5 A micrometer screw gauge is used to measure the diameter of a copper wire. 9702/13/M/J/10

The reading with the wire in position is shown in diagram 1. The wire is removed and the jaws of the micrometer are closed. The new reading is shown in diagram 2.

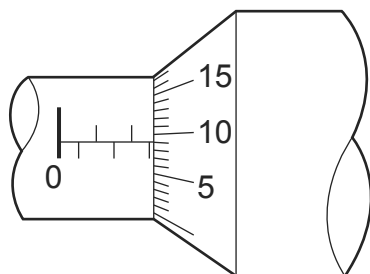

diagram 1

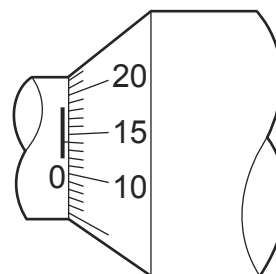

diagram 2

What is the diameter of the wire?

- A** 1.90 mm      **B** 2.45 mm      **C** 2.59 mm      **D** 2.73 mm
- 5 A quantity  $x$  is to be determined from the equation 9702/12/O/N/10

$$x = P - Q.$$

$P$  is measured as  $1.27 \pm 0.02 \text{ m}$ .

$Q$  is measured as  $0.83 \pm 0.01 \text{ m}$ .

What is the percentage uncertainty in  $x$  to one significant figure?

- A** 0.4%      **B** 2%      **C** 3%      **D** 7%

- 3 A student finds the density of a liquid by measuring its mass and its volume. The following is a summary of his measurements.

9702/12/M/J/10

$$\text{mass of empty beaker} = (20 \pm 1) \text{ g}$$

$$\text{mass of beaker + liquid} = (70 \pm 1) \text{ g}$$

$$\text{volume of liquid} = (10.0 \pm 0.6) \text{ cm}^3$$

He correctly calculates the density of the liquid as  $5.0 \text{ g cm}^{-3}$ .

What is the uncertainty in this value?

- A**  $0.3 \text{ g cm}^{-3}$       **B**  $0.5 \text{ g cm}^{-3}$       **C**  $0.6 \text{ g cm}^{-3}$       **D**  $2.6 \text{ g cm}^{-3}$

- 3 The diagram shows a square-wave trace on the screen of a cathode-ray oscilloscope. A grid of 1 cm squares covers the screen. The time-base setting is  $10 \text{ ms cm}^{-1}$ .

9702/13/M/J/10

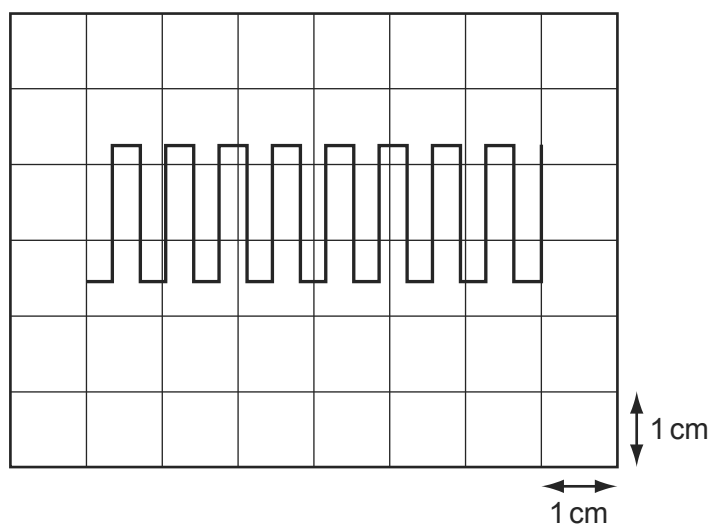

What is the approximate frequency of the square wave?

- A** 70 Hz      **B** 140 Hz      **C** 280 Hz      **D** 1400 Hz

- 4 A student finds the density of a liquid by measuring its mass and its volume. The following is a summary of his measurements.

9702/13/M/J/10

$$\text{mass of empty beaker} = (20 \pm 1) \text{ g}$$

$$\text{mass of beaker + liquid} = (70 \pm 1) \text{ g}$$

$$\text{volume of liquid} = (10.0 \pm 0.6) \text{ cm}^3$$

He correctly calculates the density of the liquid as  $5.0 \text{ g cm}^{-3}$ .

What is the uncertainty in this value?

- A**  $0.3 \text{ g cm}^{-3}$       **B**  $0.5 \text{ g cm}^{-3}$       **C**  $0.6 \text{ g cm}^{-3}$       **D**  $2.6 \text{ g cm}^{-3}$

- 4 The angular deflection of the needle of an ammeter varies with the current passing through the ammeter as shown in the graph.

9702/11/O/N/10

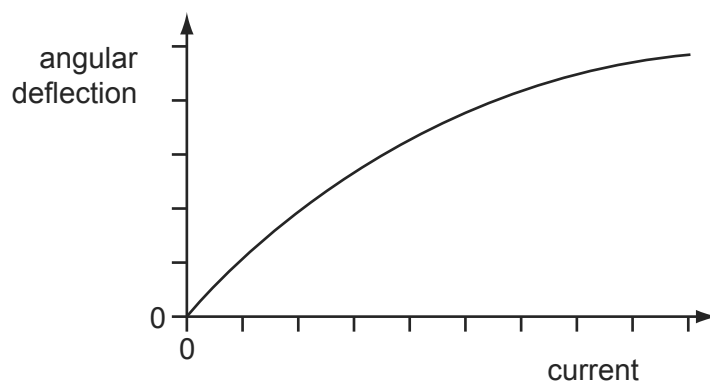

Which diagram could represent the appearance of the scale on this meter?

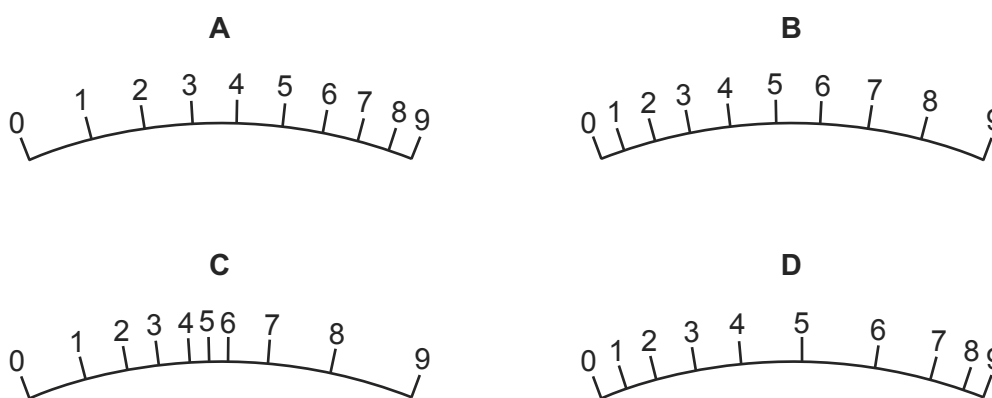

- 5 The diagram shows a cathode-ray oscilloscope (c.r.o.) being used to measure the rate of rotation of a flywheel.

9702/11/O/N/10

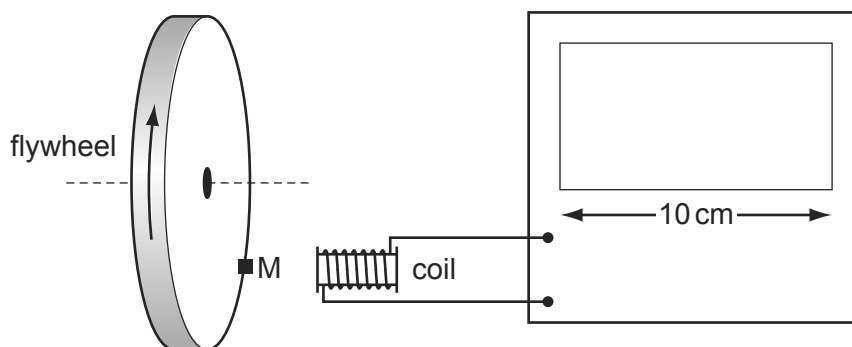

The flywheel has a small magnet M mounted on it. Each time the magnet passes the coil, a voltage pulse is generated, which is passed to the c.r.o. The display of the c.r.o. is 10 cm wide. The flywheel is rotating at a rate of about 3000 revolutions per minute.

Which time-base setting will display clearly separate pulses on the screen?

- A  $1 \text{ s cm}^{-1}$       B  $10 \text{ ms cm}^{-1}$       C  $100 \mu\text{s cm}^{-1}$       D  $1 \mu\text{s cm}^{-1}$

- 6 A fixed quantity  $x_0$  is measured many times in an experiment that has experimental uncertainty. A graph is plotted to show the number  $n$  of times that a particular value  $x$  is obtained. 9702/11/O/N/10

Which graph could be obtained if the measurement of  $x_0$  has a large systematic error but a small random error?

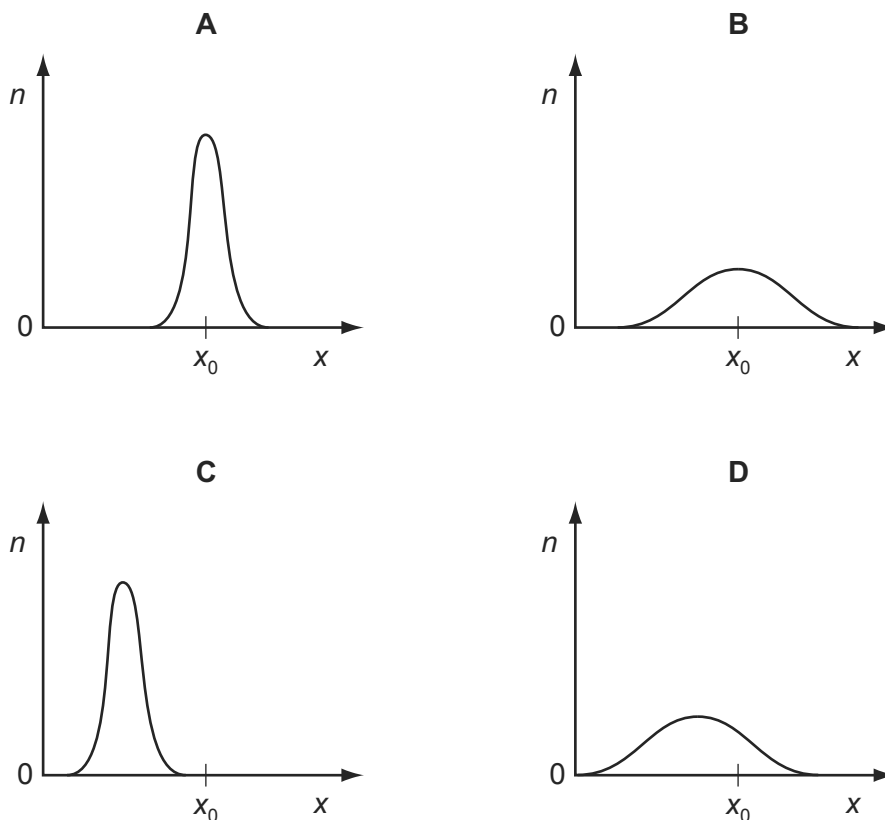

- 2 The diagram shows a cathode-ray oscilloscope (c.r.o.) being used to measure the rate of rotation of a flywheel. 9702/13/O/N/10

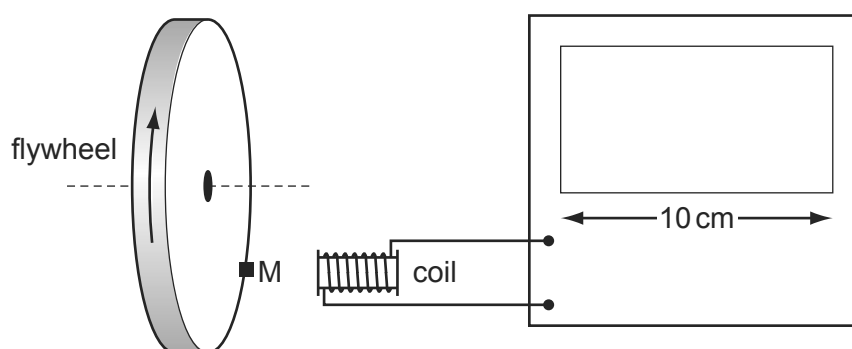

The flywheel has a small magnet  $M$  mounted on it. Each time the magnet passes the coil, a voltage pulse is generated, which is passed to the c.r.o. The display of the c.r.o. is 10 cm wide. The flywheel is rotating at a rate of about 3000 revolutions per minute.

Which time-base setting will display clearly separate pulses on the screen?

- A  $1 \text{ s cm}^{-1}$       B  $10 \text{ ms cm}^{-1}$       C  $100 \mu\text{s cm}^{-1}$       D  $1 \mu\text{s cm}^{-1}$



- 3 A fixed quantity  $x_0$  is measured many times in an experiment that has experimental uncertainty. A graph is plotted to show the number  $n$  of times that a particular value  $x$  is obtained. 9702/13/O/N/10

Which graph could be obtained if the measurement of  $x_0$  has a large systematic error but a small random error?

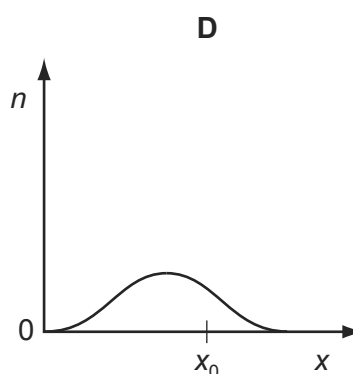
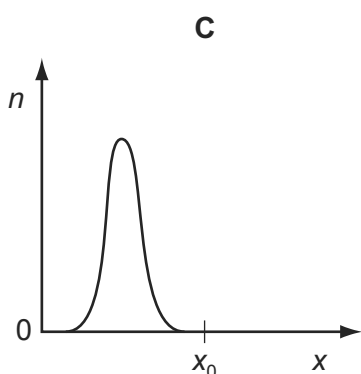
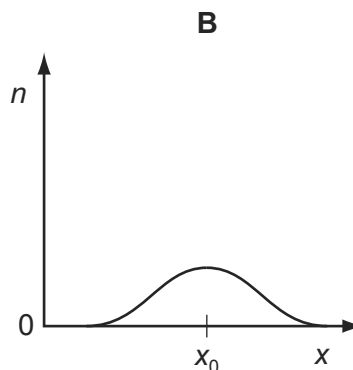
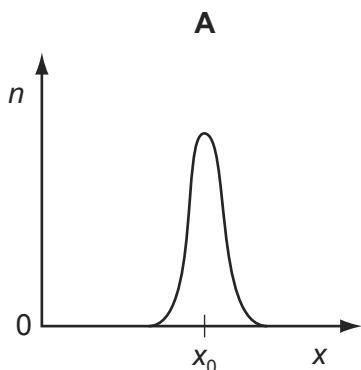

- 4 The uncertainty in the value of the momentum of a trolley passing between two points X and Y varies with the choice of measuring devices. 9702/12/M/J/11

Measurements for the same trolley made by different instruments were recorded.

- 1 distance between X and Y using a metre rule with cm divisions = 0.55 m
- 2 distance between X and Y using a metre rule with mm divisions = 0.547 m
- 3 timings using a wristwatch measuring to the nearest 0.5 s at X = 0.0 s and at Y = 4.5 s
- 4 timings using light gates measuring to the nearest 0.1 s at X = 0.0 s and at Y = 4.3 s
- 5 mass of trolley using a balance measuring to the nearest g =  $6.4 \times 10^{-2}$  kg
- 6 mass of trolley using a balance measuring to the nearest 10 g =  $6 \times 10^{-2}$  kg

Which measurements, one for each quantity measured, lead to the least uncertainty in the value of the momentum of the trolley?

- A** 1, 3 and 6      **B** 1, 4 and 6      **C** 2, 3 and 6      **D** 2, 4 and 5

- 5 The angular deflection of the needle of an ammeter varies with the current passing through the ammeter as shown in the graph.

9702/13/O/N/10

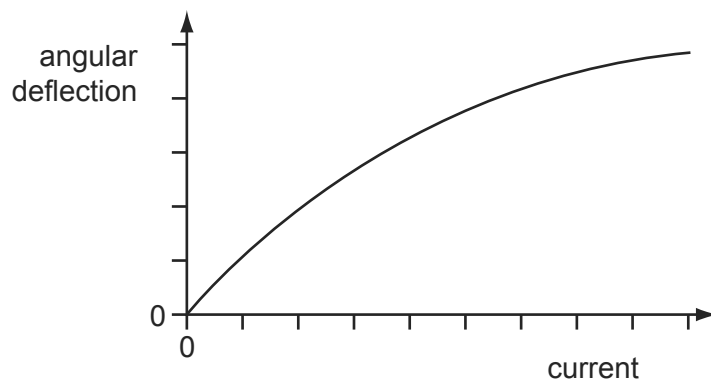

Which diagram could represent the appearance of the scale on this meter?

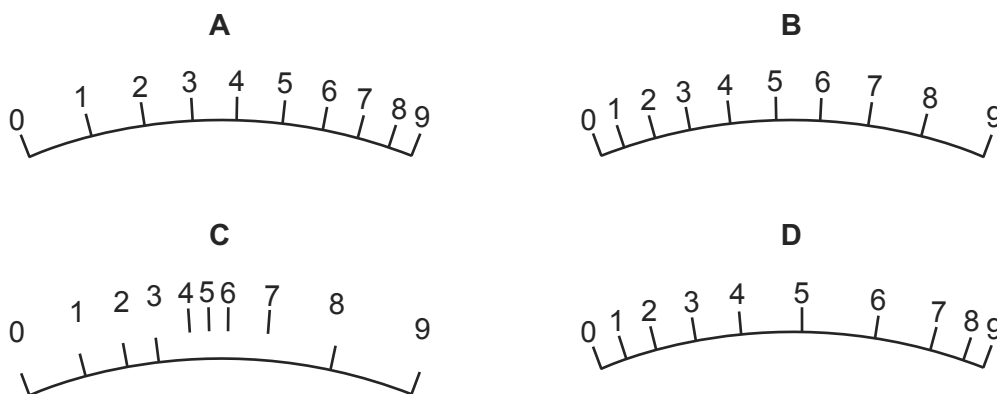

- 5 The time-base on a cathode-ray oscilloscope is set at  $6 \text{ ms/cm}$ .

9702/12/M/J/11

A trace consisting of two pulses is recorded as shown in the diagram.

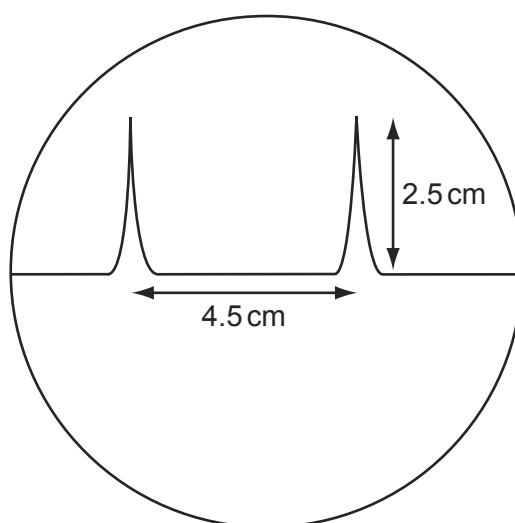

What is the time interval between the two pulses?

- A** 0.42 ms      **B** 0.75 ms      **C** 1.33 ms      **D** 27 ms

- 4 The diagram shows a trace of a wave on a cathode-ray oscilloscope.

9702/11/M/J/11

The vertical and horizontal gridlines have a spacing of 1.0 cm. The voltage scaling is  $4 \text{ V cm}^{-1}$  and the time scaling is  $5 \text{ ms cm}^{-1}$ .

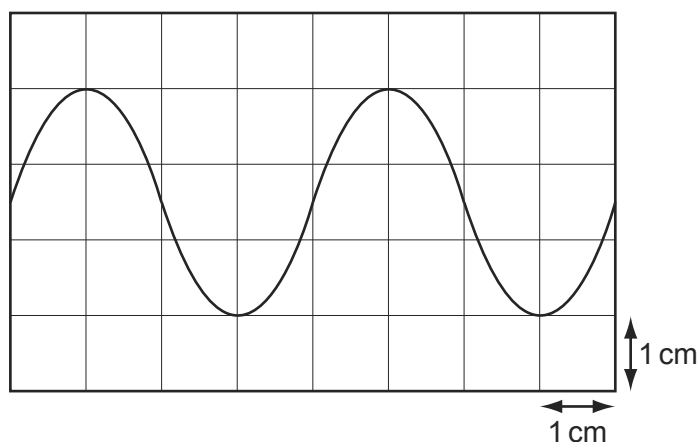

What are the amplitude and period of the wave?

	amplitude/V	period/ms
<b>A</b>	1.5	4
<b>B</b>	5.0	10
<b>C</b>	6.0	20
<b>D</b>	12.0	20

- 4 A cylindrical tube rolling down a slope of inclination  $\theta$  moves a distance  $L$  in time  $T$ . The equation relating these quantities is

9702/11/O/N/11

$$L \left( 3 + \frac{a^2}{P} \right) = QT^2 \sin \theta$$

Where  $a$  is the internal radius of the tube and  $P$  and  $Q$  are constants.

Which line gives the correct units for  $P$  and  $Q$ ?

	$P$	$Q$
<b>A</b>	$\text{m}^2$	$\text{m}^2 \text{s}^{-2}$
<b>B</b>	$\text{m}^2$	$\text{m s}^{-2}$
<b>C</b>	$\text{m}^2$	$\text{m}^3 \text{s}^{-2}$
<b>D</b>	$\text{m}^3$	$\text{m s}^{-2}$

- 5 The diagram shows an experiment to measure the speed of a small ball falling at constant speed through a clear liquid in a glass tube.

9702/11/M/J/11

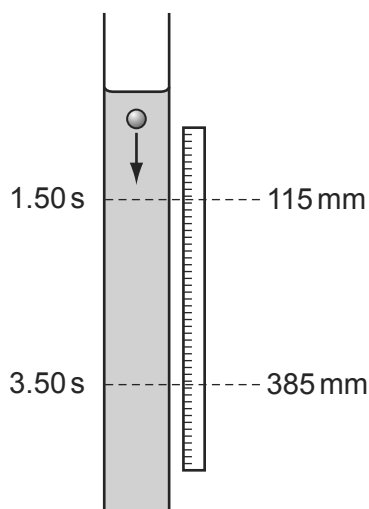

There are two marks on the tube. The top mark is positioned at  $115 \pm 1$  mm on the adjacent rule and the lower mark at  $385 \pm 1$  mm. The ball passes the top mark at  $1.50 \pm 0.02$  s and passes the lower mark at  $3.50 \pm 0.02$  s.

The constant speed of the ball is calculated by  $\frac{385 - 115}{3.50 - 1.50} = \frac{270}{2.00} = 135 \text{ mm s}^{-1}$ .

Which expression calculates the fractional uncertainty in the value of this speed?

- A  $\frac{2}{270} + \frac{0.04}{2.00}$
- B  $\frac{2}{270} - \frac{0.04}{2.00}$
- C  $\frac{1}{270} \times \frac{0.02}{2.00}$
- D  $\frac{1}{270} \div \frac{0.02}{2.00}$

- 5 The speedometer in a car consists of a pointer which rotates. The pointer is situated several millimetres from a calibrated scale.

9702/12/O/N/11

What could cause a random error in the driver's measurement of the car's speed?

- A The car's speed is affected by the wind direction.
- B The driver's eye is not always in the same position in relation to the pointer.
- C The speedometer does not read zero when the car is at rest.
- D The speedometer reads 10% higher than the car's actual speed.

- 4 The diagram shows an experiment to measure the speed of a small ball falling at constant speed through a clear liquid in a glass tube.

9702/13/M/J/11

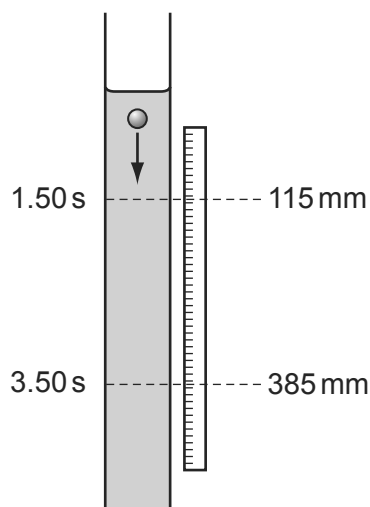

There are two marks on the tube. The top mark is positioned at  $115 \pm 1$  mm on the adjacent rule and the lower mark at  $385 \pm 1$  mm. The ball passes the top mark at  $1.50 \pm 0.02$  s and passes the lower mark at  $3.50 \pm 0.02$  s.

The constant speed of the ball is calculated by  $\frac{385 - 115}{3.50 - 1.50} = \frac{270}{2.00} = 135 \text{ mm s}^{-1}$ .

Which expression calculates the fractional uncertainty in the value of this speed?

- A  $\frac{2}{270} + \frac{0.04}{2.00}$
- B  $\frac{2}{270} - \frac{0.04}{2.00}$
- C  $\frac{1}{270} \times \frac{0.02}{2.00}$
- D  $\frac{1}{270} \div \frac{0.02}{2.00}$

- 4 A micrometer is used to measure the diameters of two cylinders.

9702/12/O/N/11

diameter of first cylinder =  $12.78 \pm 0.02$  mm

diameter of second cylinder =  $16.24 \pm 0.03$  mm

The difference in the diameters is calculated.

What is the uncertainty in this difference?

- A  $\pm 0.01$  mm      B  $\pm 0.02$  mm      C  $\pm 0.03$  mm      D  $\pm 0.05$  mm

- 5 The diagram shows a trace of a wave on a cathode-ray oscilloscope.

9702/13/M/J/11

The vertical and horizontal gridlines have a spacing of 1.0 cm. The voltage scaling is  $4 \text{ V cm}^{-1}$  and the time scaling is  $5 \text{ ms cm}^{-1}$ .

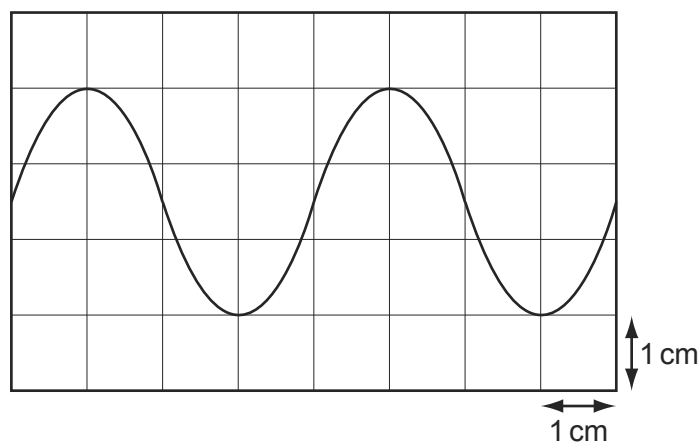

What are the amplitude and period of the wave?

	amplitude/V	period/ms
<b>A</b>	1.5	4
<b>B</b>	5.0	10
<b>C</b>	6.0	20
<b>D</b>	12.0	20

- 5 The Young modulus of the material of a wire is to be found. The Young modulus  $E$  is given by the equation below.

9702/11/O/N/11

$$E = \frac{4Fl}{\pi d^2 x}$$

The wire is extended by a known force and the following measurements are made.

Which measurement has the largest effect on the uncertainty in the value of the calculated Young modulus?

	measurement	symbol	value
<b>A</b>	length of wire before force applied	$l$	$2.043 \pm 0.002 \text{ m}$
<b>B</b>	diameter of wire	$d$	$0.54 \pm 0.02 \text{ mm}$
<b>C</b>	force applied	$F$	$19.62 \pm 0.01 \text{ N}$
<b>D</b>	extension of wire with force applied	$x$	$5.2 \pm 0.2 \text{ mm}$

- 3 The Young modulus of the material of a wire is to be found. The Young modulus  $E$  is given by the equation below. 9702/13/O/N/11

$$E = \frac{4Fl}{\pi d^2 x}$$

The wire is extended by a known force and the following measurements are made.

Which measurement has the largest effect on the uncertainty in the value of the calculated Young modulus?

	measurement	symbol	value
<b>A</b>	length of wire before force applied	$l$	$2.043 \pm 0.002$ m
<b>B</b>	diameter of wire	$d$	$0.54 \pm 0.02$ mm
<b>C</b>	force applied	$F$	$19.62 \pm 0.01$ N
<b>D</b>	extension of wire with force applied	$x$	$5.2 \pm 0.2$ mm

- 5 A cylindrical tube rolling down a slope of inclination  $\theta$  moves a distance  $L$  in time  $T$ . The equation relating these quantities is 9702/13/O/N/11

$$L \left( 3 + \frac{a^2}{P} \right) = QT^2 \sin \theta$$

Where  $a$  is the internal radius of the tube and  $P$  and  $Q$  are constants.

Which line gives the correct units for  $P$  and  $Q$ ?

	$P$	$Q$
<b>A</b>	$\text{m}^2$	$\text{m}^2 \text{s}^{-2}$
<b>B</b>	$\text{m}^2$	$\text{m s}^{-2}$
<b>C</b>	$\text{m}^2$	$\text{m}^3 \text{s}^{-2}$
<b>D</b>	$\text{m}^3$	$\text{m s}^{-2}$

- 5 In an experiment, a radio-controlled car takes  $2.50 \pm 0.05$  s to travel  $40.0 \pm 0.1$  m. 9702/11/M/J/12

What is the car's average speed and the uncertainty in this value?

- A**  $16 \pm 1 \text{ m s}^{-1}$   
**B**  $16.0 \pm 0.2 \text{ m s}^{-1}$   
**C**  $16.0 \pm 0.4 \text{ m s}^{-1}$   
**D**  $16.00 \pm 0.36 \text{ m s}^{-1}$

- 4 A light-meter measures the intensity  $I$  of the light falling on it. Theory suggests that  $I$  varies inversely as the square of the distance  $d$ .

9702/11/M/J/12

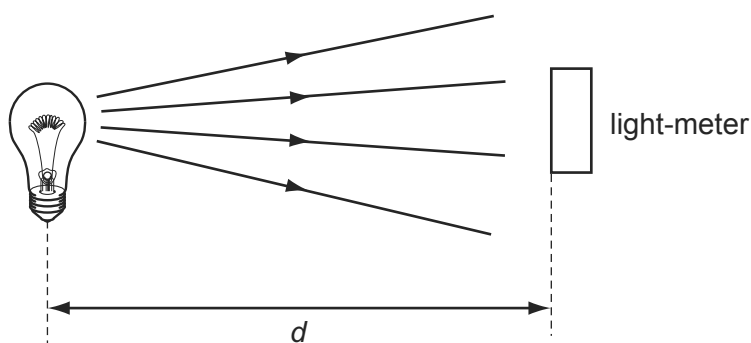

Which graph of the results supports this theory?

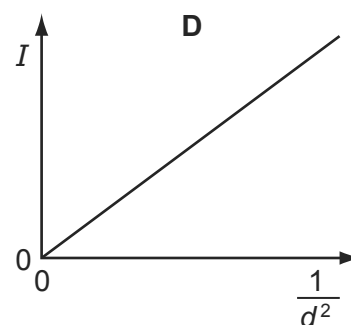
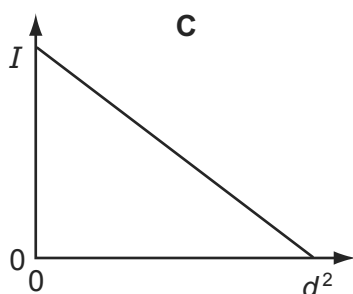
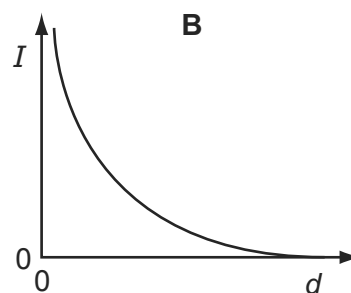
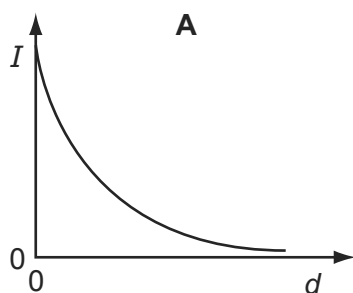

- 6 The diagram shows two complete pulses on the screen of a cathode-ray oscilloscope. A grid of 1 cm squares covers the screen. The time-base setting is  $1 \mu\text{s cm}^{-1}$ .

9702/12/M/J/12

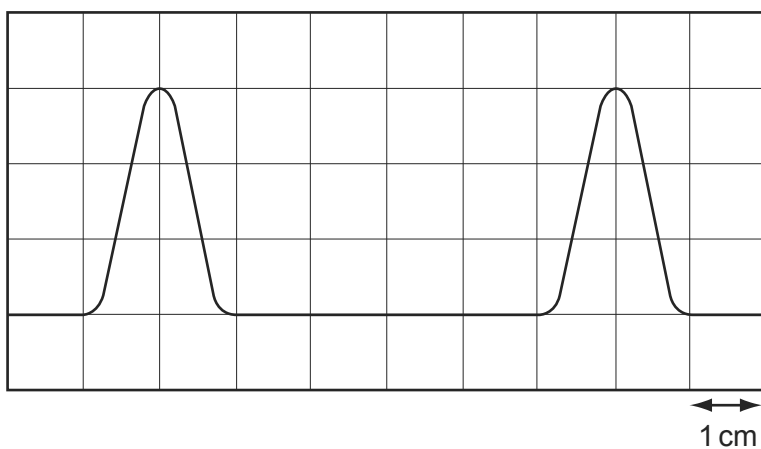

How long does each pulse last?

- A**  $2 \mu\text{s}$       **B**  $3 \mu\text{s}$       **C**  $4 \mu\text{s}$       **D**  $6 \mu\text{s}$



- 4 The diameter of a cylindrical metal rod is measured using a micrometer screw gauge. 9702/12/M/J/12

The diagram below shows an enlargement of the scale on the micrometer screw gauge when taking the measurement.

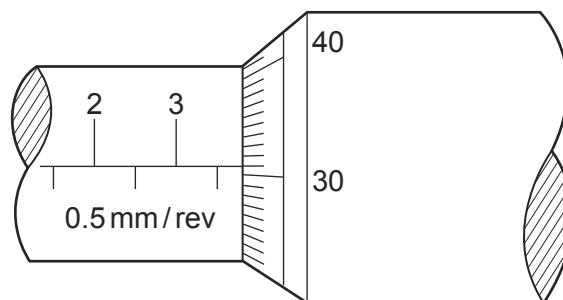

What is the cross-sectional area of the rod?

- A 3.81 mm<sup>2</sup>      B 11.4 mm<sup>2</sup>      C 22.8 mm<sup>2</sup>      D 45.6 mm<sup>2</sup>
- 5 A mass is dropped from rest, and falls through a distance of 2.0 m in a vacuum. An observer records the time taken for the mass to fall through this distance using a manually operated stopwatch and repeats the measurements a further two times. The average result of these measured times, displayed in the table below, was used to determine a value for the acceleration of free fall. This was calculated to be 9.8 ms<sup>-2</sup>. 9702/12/M/J/12

	first measurement	second measurement	third measurement	average
time/s	0.6	0.73	0.59	0.64

Which statement best relates to the experiment?

- A The measurements are precise and accurate with no evidence of random errors.
- B The measurements are not accurate and not always recorded to the degree of precision of the measuring device but the calculated experimental result is accurate.
- C The measurements are not always recorded to the degree of precision of the measuring device but are accurate. Systematic errors may be present.
- D The range of results shows that there were random errors made but the calculated value is correct so the experiment was successful.
- 4 In an experiment, a radio-controlled car takes  $2.50 \pm 0.05$  s to travel  $40.0 \pm 0.1$  m. 9702/13/M/J/12

What is the car's average speed and the uncertainty in this value?

- A  $16 \pm 1$  ms<sup>-1</sup>
- B  $16.0 \pm 0.2$  ms<sup>-1</sup>
- C  $16.0 \pm 0.4$  ms<sup>-1</sup>
- D  $16.00 \pm 0.36$  ms<sup>-1</sup>

- 5 A light-meter measures the intensity  $I$  of the light falling on it. Theory suggests that  $I$  varies inversely as the square of the distance  $d$ .

9702/13/M/J/12

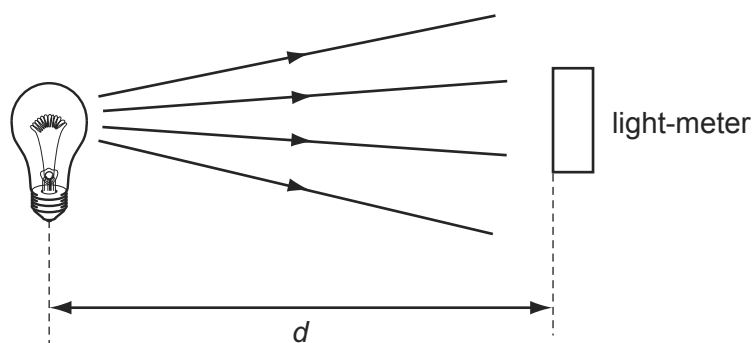

Which graph of the results supports this theory?

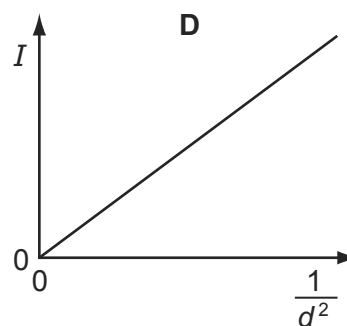
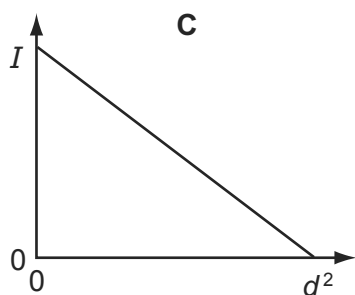
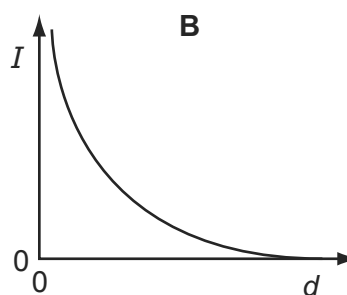
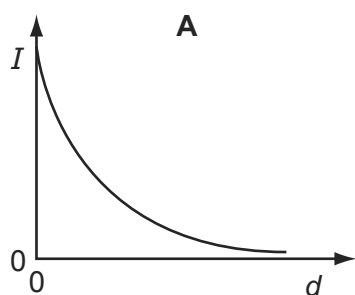

- 5 A student is given a reel of wire of diameter less than 0.2 mm and is asked to find the density of the metal.

9702/12/O/N/12

Which pair of instruments would be most suitable for finding the **volume** of the wire?

- A balance and micrometer
- B metre rule and micrometer
- C metre rule and vernier calipers
- D micrometer and vernier calipers

- 6 Variables  $x$  and  $y$  are related by the equation  $y = p - qx$  where  $p$  and  $q$  are constants.

Values of  $x$  and  $y$  are measured experimentally. The results contain a systematic error.

9702/12/O/N/12

Which graph best represents these results?

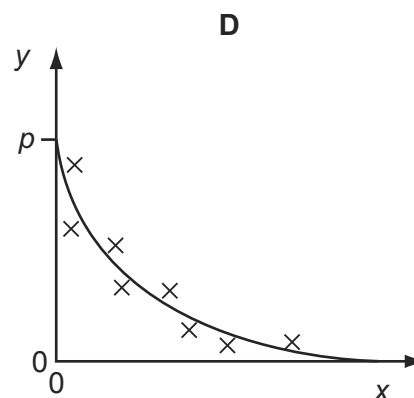
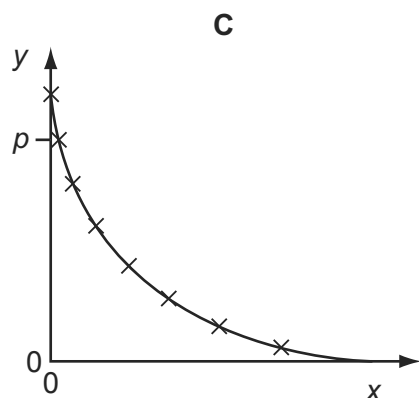
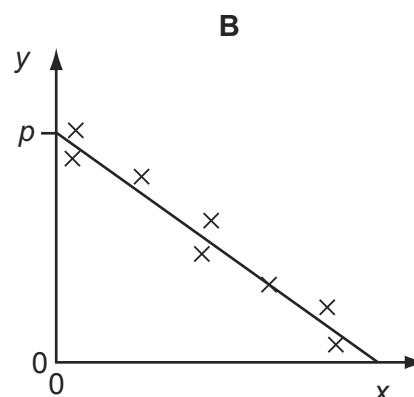
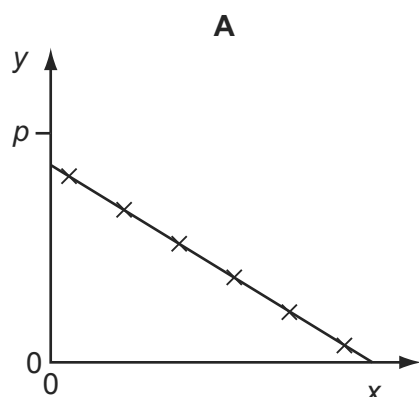

- 7 The speed of a car is calculated from measurements of the distance travelled and the time taken.

9702/12/O/N/12

The distance is measured as 200 m, with an uncertainty of  $\pm 2$  m.

The time is measured as 10.0 s, with an uncertainty of  $\pm 0.2$  s.

What is the percentage uncertainty in the calculated speed?

- A**  $\pm 0.5\%$       **B**  $\pm 1\%$       **C**  $\pm 2\%$       **D**  $\pm 3\%$
- 8 A science museum designs an experiment to show the fall of a feather in a vertical glass vacuum tube.

9702/12/O/N/12

The time of fall from rest is to be close to 0.5 s.

What length of tube is required?

- A** 1.3 m      **B** 2.5 m      **C** 5.0 m      **D** 10.0 m

- 5 The density of the material of a coil of thin wire is to be found.

Which set of instruments could be used to do this most accurately?

- A metre rule, protractor, spring balance
- B micrometer, metre rule, top-pan balance
- C stopwatch, newton-meter, vernier calipers
- D tape measure, vernier calipers, lever balance

- 6 A quantity  $X$  varies with temperature  $\theta$  as shown.

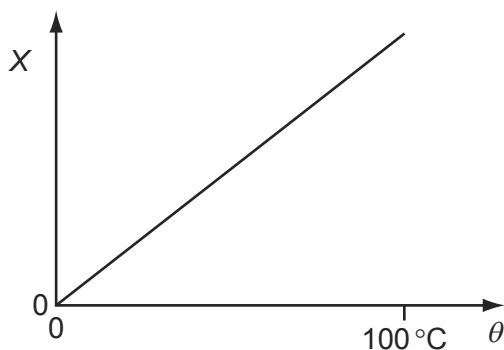

$\theta$  is determined from the corresponding values of  $X$  by using this graph.  
 $X$  is measured with a percentage uncertainty of  $\pm 1\%$  of its value at all temperatures.

Which statement about the uncertainty in  $\theta$  is correct?

- A The percentage uncertainty in  $\theta$  is least near  $0^\circ\text{C}$ .
  - B The percentage uncertainty in  $\theta$  is least near  $100^\circ\text{C}$ .
  - C The actual uncertainty in  $\theta$  is least near  $0^\circ\text{C}$ .
  - D The actual uncertainty in  $\theta$  is least near  $100^\circ\text{C}$ .
- 7 The measurement of a physical quantity may be subject to random errors and to systematic errors.

Which statement is correct?

- A Random errors can be reduced by taking the average of several measurements.
- B Random errors are always caused by the person taking the measurement.
- C A systematic error cannot be reduced by adjusting the apparatus.
- D A systematic error results in a different reading each time the measurement is taken.

- 5 A cathode-ray oscilloscope displays a square wave, as shown in the diagram.

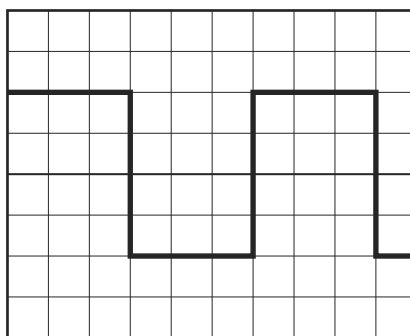

The time-base setting is 0.20 ms per division.

What is the frequency of the square wave?

- A** 8.3 Hz      **B** 830 Hz      **C** 1300 Hz      **D** 1700 Hz
- 6 The diagram shows the stem of a Celsius thermometer, marked to show initial and final temperature values.

9702/13/M/J/13

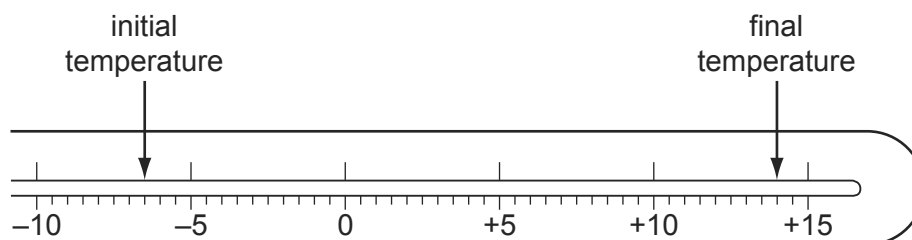

What is the temperature change expressed to an appropriate number of significant figures?

- A** 14 °C      **B** 20.5 °C      **C** 21 °C      **D** 22.0 °C
- 5 A student takes measurements of the current in a resistor of constant resistance and the potential difference (p.d.) across it. The readings are then used to plot a graph of current against p.d.

9702/13/M/J/13

There is a systematic error in the current readings.

How could this be identified from the graph?

- A** At least one anomalous data point can be identified.  
**B** The data points are scattered about the straight line of best fit.  
**C** The graph is a curve, not a straight line.  
**D** The straight line graph does not pass through the origin.

- 5 In an experiment to determine the acceleration of free fall  $g$ , the period of oscillation  $T$  and length  $l$  of a simple pendulum were measured. The uncertainty in the measurement of  $l$  is estimated to be 4%, and the uncertainty in the measurement of  $T$  is estimated to be 1%. 9702/11/M/J/13

The value of  $g$  is determined using the formula

$$g = \frac{4\pi^2 l}{T^2}.$$

What is the uncertainty in the calculated value for  $g$ ?

- A** 2%                      **B** 3%                      **C** 5%                      **D** 6%
- 6 The Y-input terminals of a cathode-ray oscilloscope (c.r.o.) are connected to a supply of amplitude 5.0V and frequency 50Hz. The time-base is set at 10ms per division and the Y-gain at 5.0V per division. 9702/11/M/J/13

Which trace is obtained?

**A**

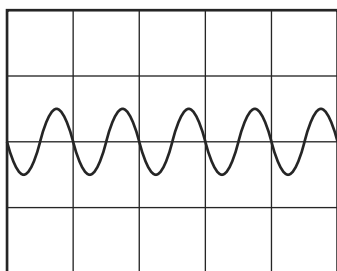

**B**

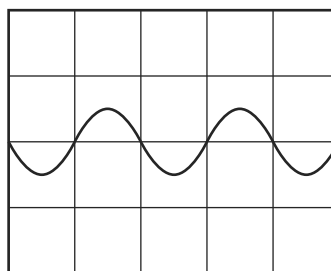

**C**

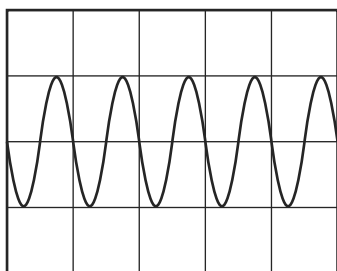

**D**

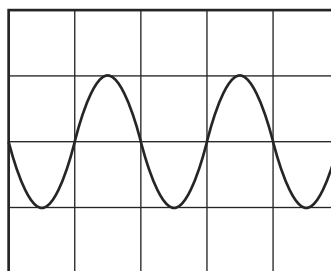

- 4 A student carried out an experiment in which an electric current was known to decrease with time. The readings he found, from first to last, were 3.62 mA, 2.81 mA, 1.13 mA, 1.76 mA and 0.90 mA.

9702/12/M/J/13

Which statement could **not** explain the anomalous 1.13 mA reading?

- A He has reversed the third and fourth readings in the results table.  
 B He read the ammeter incorrectly; the reading should have been 2.13 mA.  
 C He took the current reading at the wrong time.  
 D There was a systematic error in the readings from the ammeter.
- 5 The diagram shows a calibration curve for a thermistor, drawn with an unusual scale on the vertical axis.

9702/12/M/J/13

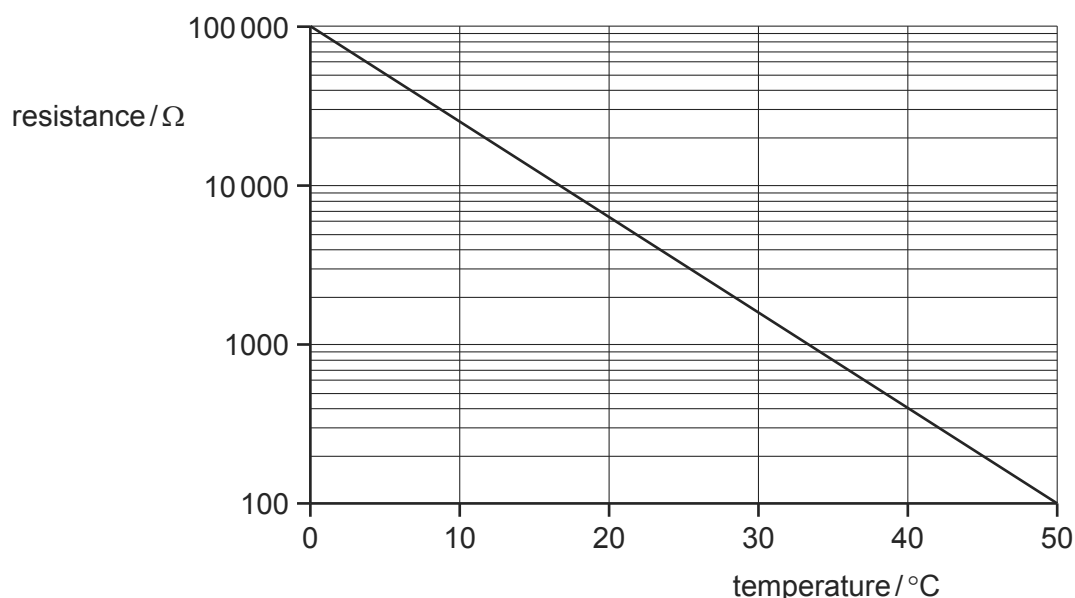

What is the thermistor resistance corresponding to a temperature of 40 °C?

- A 130 Ω      B 150 Ω      C 400 Ω      D 940 Ω
- 6 What will reduce the systematic errors when taking a measurement?
- A adjusting the needle on a voltmeter so that it reads zero when there is no potential difference across it  
 B measuring the diameter of a wire at different points and taking the average  
 C reducing the parallax effects by using a marker and a mirror when measuring the amplitude of oscillation of a pendulum  
 D timing 20 oscillations, rather than a single oscillation, when finding the period of a pendulum

9702/13/O/N/12

- 7 In an experiment to determine the acceleration of free fall  $g$ , the time  $t$  taken for a ball to fall through distance  $s$  was measured. The uncertainty in the measurement of  $s$  is estimated to be 2%. The uncertainty in the measurement of  $t$  is estimated to be 3%. 9702/13/O/N/12

The value of  $g$  is determined using the equation

$$g = \frac{2s}{t^2}.$$

What is the uncertainty in the calculated value of  $g$ ?

- A** 1%                      **B** 5%                      **C** 8%                      **D** 11%
- 4 A signal that repeats periodically is displayed on the screen of a cathode-ray oscilloscope. 9702/11/O/N/13



The screen has 1 cm squares and the time base is set at  $2.00 \text{ ms cm}^{-1}$ .

What is the frequency of this periodic signal?

- A** 50 Hz                      **B** 100 Hz                      **C** 125 Hz                      **D** 200 Hz
- 5 A micrometer screw gauge is used to measure the diameter of a small uniform steel sphere. The micrometer reading is  $5.00 \text{ mm} \pm 0.01 \text{ mm}$ . 9702/11/O/N/13

What will be the percentage uncertainty in a calculation of the volume of the sphere, using these values?

- A** 0.2%                      **B** 0.4%                      **C** 0.6%                      **D** 1.2%
- 6 A student wishes to determine the density  $\rho$  of lead. She measures the mass and diameter of a small sphere of lead: 9702/13/O/N/13

$$\text{mass} = (0.506 \pm 0.005) \text{ g}$$

$$\text{diameter} = (2.20 \pm 0.02) \text{ mm}.$$

What is the best estimate of the percentage uncertainty in her value of  $\rho$ ?

- A** 1.9%                      **B** 2.0%                      **C** 2.8%                      **D** 3.7%



- 5 An uncalibrated analogue voltmeter P is connected in parallel with another voltmeter Q which is known to be accurately calibrated. For a range of values of potential difference (p.d.), readings are taken from the two meters.

9702/13/O/N/13

The diagram shows the calibration graph obtained.

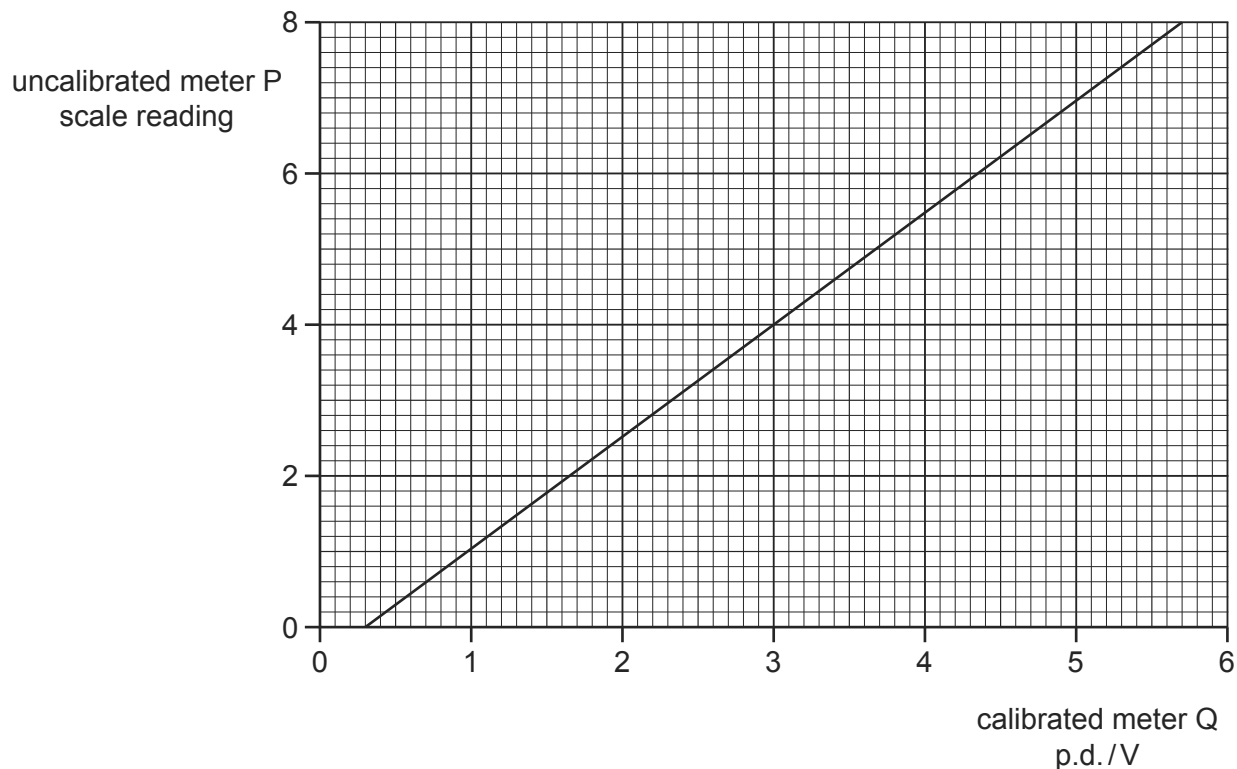

The graph shows that meter P has a zero error. This meter is now adjusted to remove this zero error. When the meter is recalibrated, the gradient of the calibration graph is found to be unchanged.

What is the new scale reading on meter P when it is used to measure a p.d. of 5.0V?

- A** 6.6                      **B** 6.7                      **C** 7.2                      **D** 7.4
- 4 An experiment is carried out to measure the resistance of a wire. 9702/11/M/J/14

The current in the wire is  $(1.0 \pm 0.2)\text{A}$  and the potential difference across the wire is  $(8.0 \pm 0.4)\text{V}$ .

What is the resistance of the wire and its uncertainty?

- A**  $(8.0 \pm 0.2)\Omega$   
**B**  $(8.0 \pm 0.6)\Omega$   
**C**  $(8 \pm 1)\Omega$   
**D**  $(8 \pm 2)\Omega$

- 5 The Young modulus of the material of a wire is to be found. The Young modulus  $E$  is given by the equation below.

9702/11/M/J/14

$$E = \frac{4Fl}{\pi d^2 x}$$

The wire is extended by a known force and the following measurements are made.

Which measurement has the largest effect on the uncertainty in the value of the calculated Young modulus?

	measurement	symbol	value
<b>A</b>	length of wire before force applied	$l$	$2.043 \pm 0.002$ m
<b>B</b>	diameter of wire	$d$	$0.54 \pm 0.02$ mm
<b>C</b>	force applied	$F$	$19.62 \pm 0.01$ N
<b>D</b>	extension of wire with force applied	$x$	$5.2 \pm 0.2$ mm

- 3 A cathode-ray oscilloscope (c.r.o.) is connected to an alternating voltage. The following trace is produced on the screen.

9702/12/M/J/14

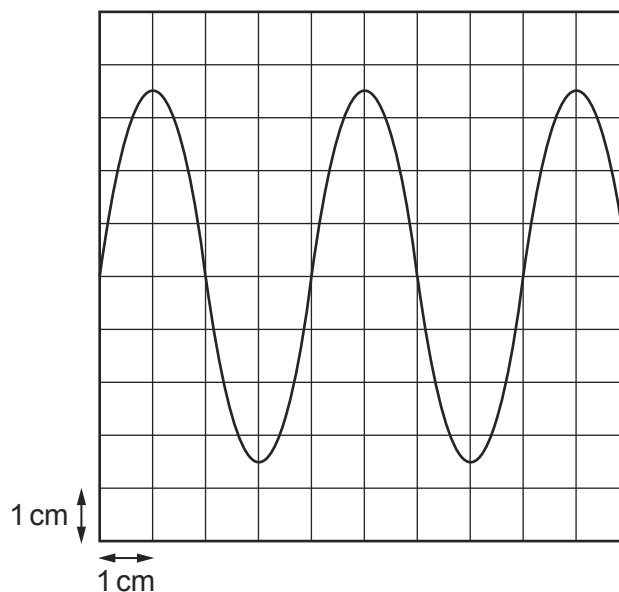

The oscilloscope time-base setting is  $0.5 \text{ ms cm}^{-1}$  and the Y-plate sensitivity is  $2 \text{ V cm}^{-1}$ .

Which statement about the alternating voltage is correct?

- A** The amplitude is 3.5 cm.
- B** The frequency is 0.5 kHz.
- C** The period is 1 ms.
- D** The wavelength is 4 cm.

- 4 A quantity  $y$  is to be determined from the equation shown.

9702/12/M/J/14

$$y = \frac{px}{q^2}$$

The percentage uncertainties in  $p$ ,  $x$  and  $q$  are shown.

	percentage uncertainty
$p$	6%
$x$	2%
$q$	4%

What is the percentage uncertainty in  $y$ ?

- A** 0.5%      **B** 1%      **C** 16%      **D** 192%
- 5 A thermometer can be read to an accuracy of  $\pm 0.5^\circ\text{C}$ . This thermometer is used to measure a temperature rise from  $40^\circ\text{C}$  to  $100^\circ\text{C}$ .

9702/12/M/J/14

What is the percentage uncertainty in the measurement of the temperature rise?

- A** 0.5%      **B** 0.8%      **C** 1.3%      **D** 1.7%
- 4 The resistance of a lamp is calculated from the value of the potential difference (p.d.) across it and the value of the current passing through it.

9702/13/M/J/14

Which statement correctly describes how to combine the uncertainties in the p.d. and in the current?

- A** Add together the actual uncertainty in the p.d. and the actual uncertainty in the current.
- B** Add together the percentage uncertainty in the p.d. and the percentage uncertainty in the current.
- C** Subtract the actual uncertainty in the current from the actual uncertainty in the p.d.
- D** Subtract the percentage uncertainty in the current from the percentage uncertainty in the p.d.
- 6 A digital caliper is used to measure the 28.50 mm width of a plastic ruler. The digital caliper reads to the nearest 0.01 mm.

9702/13/M/J/14

What is the correct way to record this reading?

- A**  $0.02850 \pm 0.01 \text{ m}$
- B**  $0.0285 \pm 0.001 \text{ m}$
- C**  $(2.850 \pm 0.001) \times 10^{-2} \text{ m}$
- D**  $(2.850 \pm 0.001) \times 10^{-3} \text{ m}$

- 5 The display on a cathode-ray oscilloscope shows the signal produced by an electronic circuit. The time-base is set at 5.0 ns per division and the Y-gain at 10 V per division. 9702/13/M/J/14

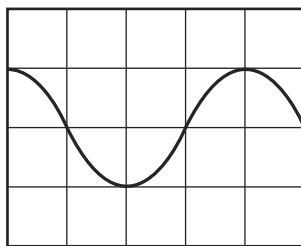

What is the frequency of the signal?

- A  $2.0 \times 10^{-8}$  Hz  
 B  $2.5 \times 10^{-2}$  Hz  
 C  $5.0 \times 10^7$  Hz  
 D  $3.1 \times 10^8$  Hz
- 1 A 0.10 kg mass is taken to Mars and then weighed on a spring balance and on a lever balance. The acceleration due to gravity on Mars is 38% of its value on Earth. 9702/11/O/N/14

What are the readings on the two balances on Mars? (Assume that on Earth  $g = 10 \text{ m s}^{-2}$ .)

	spring balance / N	lever balance / kg
A	0.38	0.038
B	0.38	0.10
C	1.0	0.038
D	1.0	0.10

- 4 A steel wire is stretched in an experiment to determine the Young modulus for steel. 9702/11/O/N/14

The uncertainties in the measurements are given below.

measurement	uncertainty
load on wire	$\pm 2\%$
length of wire	$\pm 0.2\%$
diameter of wire	$\pm 1.5\%$
extension	$\pm 1\%$

What is the percentage uncertainty in the Young modulus?

- A 1.3%      B 1.8%      C 4.7%      D 6.2%

- 5 The acceleration of free fall on the Moon is one-sixth of that on Earth.

9702/11/O/N/14

On Earth it takes time  $t$  for a stone to fall from rest a distance of 2 m.

What is the time taken for a stone to fall from rest a distance of 2 m on the Moon?

- A  $6t$                       B  $\frac{t}{6}$                       C  $t\sqrt{6}$                       D  $\frac{t}{\sqrt{6}}$

- 3 In the circuit shown, an analogue ammeter is to be recalibrated as a thermometer. The graph shows how the resistance  $R$  of the thermistor changes with temperature  $T$ .

9702/13/O/N/14

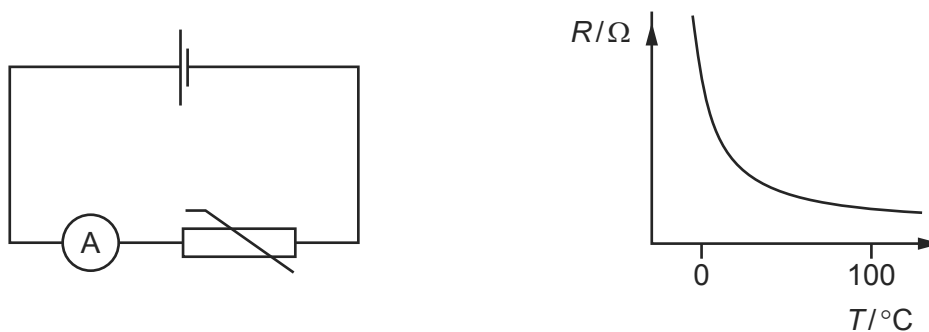

Which diagram could represent the temperature scale on the ammeter?

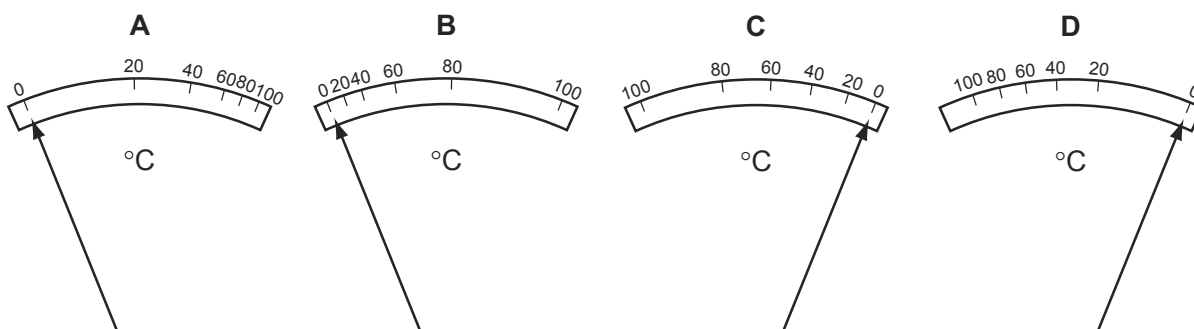

- 4 The diagram shows part of a thermometer.

9702/13/O/N/14

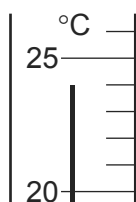

What is the correct reading on the thermometer and the uncertainty in this reading?

	reading/ $^\circ\text{C}$	uncertainty in reading/ $^\circ\text{C}$
A	24	$\pm 1$
B	24	$\pm 0.5$
C	24	$\pm 0.2$
D	24.0	$\pm 0.5$

- 5 The resistance  $R$  of a resistor is to be determined. The current  $I$  in the resistor and the potential difference  $V$  across it are measured.

9702/13/O/N/14

The results, with their uncertainties, are

$$I = (2.0 \pm 0.2) \text{ A} \qquad V = (15.0 \pm 0.5) \text{ V}.$$

The value of  $R$  is calculated to be  $7.5 \Omega$ .

What is the uncertainty in this value for  $R$ ?

- A  $\pm 0.3 \Omega$       B  $\pm 0.5 \Omega$       C  $\pm 0.7 \Omega$       D  $\pm 1 \Omega$
- 3 The speed of an aeroplane in still air is  $200 \text{ km h}^{-1}$ . The wind blows from the west at a speed of  $85.0 \text{ km h}^{-1}$ .

9702/13/M/J/15

In which direction must the pilot steer the aeroplane in order to fly due north?

- A  $23.0^\circ$  east of north  
 B  $23.0^\circ$  west of north  
 C  $25.2^\circ$  east of north  
 D  $25.2^\circ$  west of north
- 4 A student is given a reel of wire of diameter less than  $0.2 \text{ mm}$  and is asked to find the density of the metal.

9702/13/M/J/15

Which pair of instruments would be most suitable for finding the **volume** of the wire?

- A balance and micrometer  
 B metre rule and micrometer  
 C metre rule and vernier calipers  
 D micrometer and vernier calipers
- 5 Four different students use a ruler to measure the length of a  $15.0 \text{ cm}$  pencil. Their measurements are recorded on four different charts.

9702/13/M/J/15

Which chart shows measurements that are precise but **not** accurate?

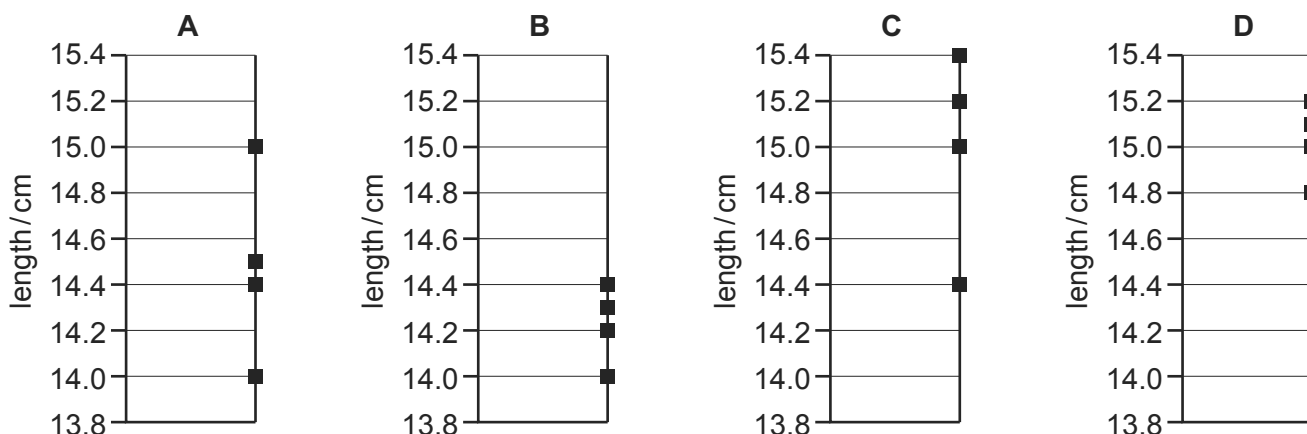

- 6 In a simple electrical circuit, the current in a resistor is measured as  $(2.50 \pm 0.05)$  mA. The resistor is marked as having a value of  $4.7 \Omega \pm 2\%$ .

9702/13/M/J/15

If these values were used to calculate the power dissipated in the resistor, what would be the percentage uncertainty in the value obtained?

- A 2%                      B 4%                      C 6%                      D 8%

- 3 An analogue ammeter has a pointer which moves over a scale. Following prolonged use, the pointer does not return fully to zero when the current is turned off and the meter has become less sensitive at higher currents than it is at lower currents.

9702/12/M/J/15

Which diagram best represents the calibration graph needed to obtain an accurate current reading?

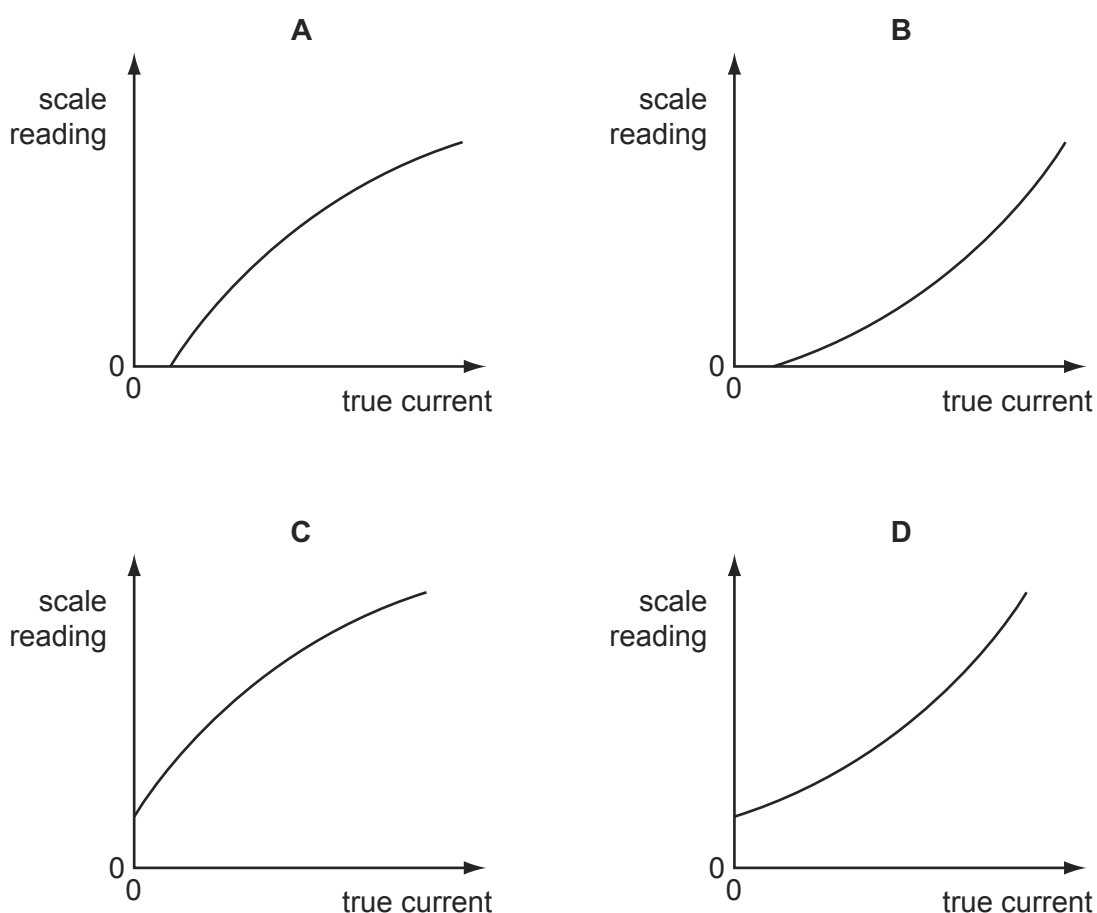

- 6 A single sheet of aluminium foil is folded twice to produce a stack of four sheets. The total thickness of the stack of sheets is measured to be  $(0.80 \pm 0.02)$  mm. This measurement is made using a digital caliper with a zero error of  $(-0.20 \pm 0.02)$  mm.

9702/12/M/J/15

What is the percentage uncertainty in the calculated thickness of a single sheet?

- A 1.0%                      B 2.0%                      C 4.0%                      D 6.7%

- 4 The arrow represents the vector R.



Which diagram does **not** represent R as two perpendicular components?

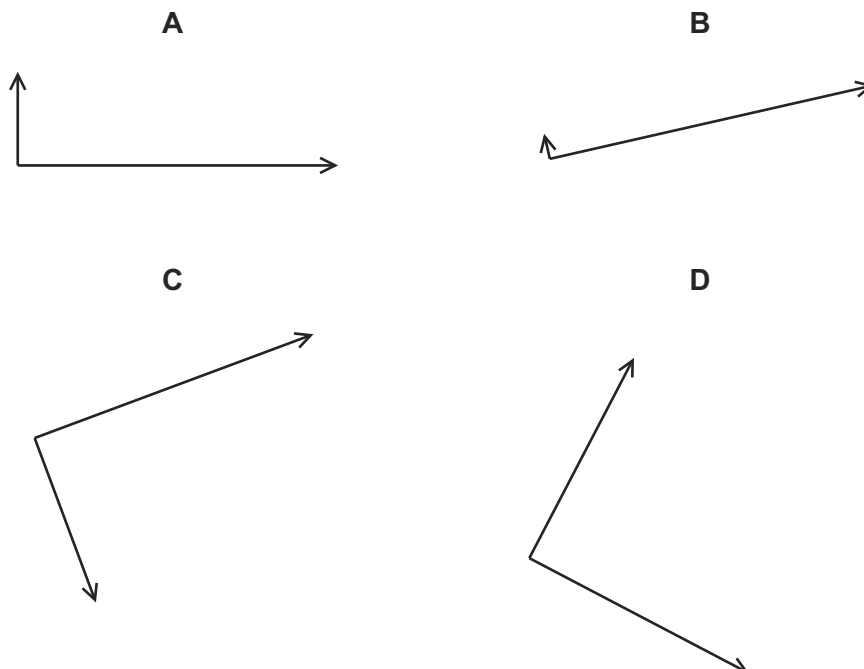

- 5 A power supply of electromotive force (e.m.f.) 50 V and negligible internal resistance is connected in series with resistors of resistance  $100\ \Omega$  and  $5\ \Omega$ , as shown.

9702/12/M/J/15

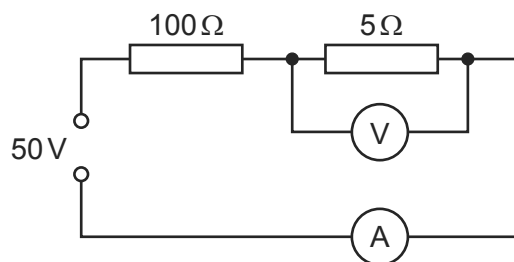

A voltmeter measures the potential difference (p.d.) across the  $5\ \Omega$  resistor and an ammeter measures the current in the circuit.

What are suitable ranges for the ammeter and for the voltmeter?

	ammeter range / A	voltmeter range / V
<b>A</b>	0–0.1	0–1
<b>B</b>	0–0.1	0–3
<b>C</b>	0–1.0	0–1
<b>D</b>	0–1.0	0–3



- 7 In an experiment to determine the acceleration of free fall  $g$ , a ball bearing is held by an electromagnet. When the current to the electromagnet is switched off, a clock starts and the ball bearing falls. After falling a distance  $h$ , the ball bearing strikes a switch to stop the clock which measures the time  $t$  of the fall.

9702/12/M/J/15

If systematic errors cause  $t$  and  $h$  to be measured incorrectly, which error **must** cause  $g$  to appear greater than  $9.81 \text{ m s}^{-2}$ ?

- A  $h$  measured as being **smaller** than it actually is and  $t$  is measured correctly
- B  $h$  measured as being **smaller** than it actually is and  $t$  measured as being **larger** than it actually is
- C  $h$  measured as being **larger** than it actually is and  $t$  measured as being **larger** than it actually is
- D  $h$  is measured correctly and  $t$  measured as being **smaller** than it actually is
- 5 The angular deflection of the needle of an ammeter varies with the current in the ammeter as shown in the graph.

9702/11/M/J/15

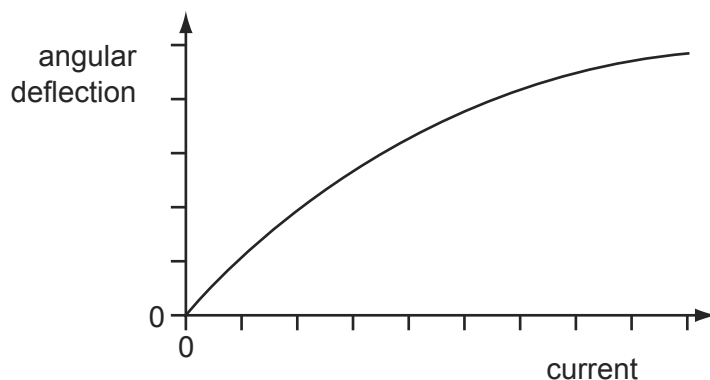

Which diagram could represent the appearance of the scale on this meter?

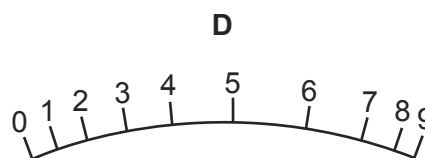
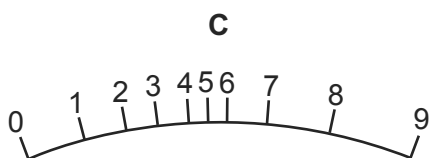
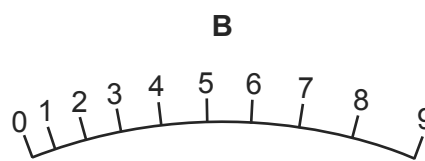
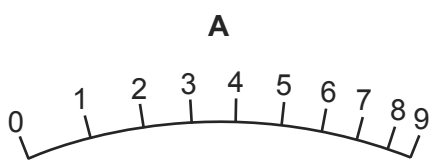

- 6 The strain energy  $W$  of a spring is determined from its spring constant  $k$  and extension  $x$ . The spring obeys Hooke's law and the value of  $W$  is calculated using the equation shown. 9702/11/M/J/15

$$W = \frac{1}{2} kx^2$$

The spring constant is  $100 \pm 2 \text{ N m}^{-1}$  and the extension is  $0.050 \pm 0.002 \text{ m}$ .

What is the percentage uncertainty in the calculated value of  $W$ ?

- A 6%                      B 10%                      C 16%                      D 32%
- 4 A whale produces sound waves of frequency 5 Hz. The waves are detected by a microphone and displayed on an oscilloscope. 9702/11/M/J/15

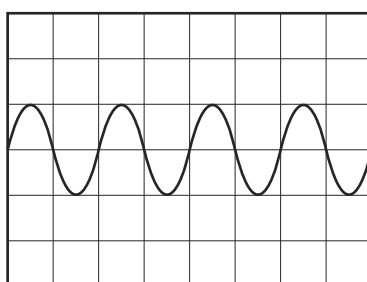

What is the time-base setting on the oscilloscope?

- A  $0.1 \text{ ms div}^{-1}$       B  $1 \text{ ms div}^{-1}$       C  $10 \text{ ms div}^{-1}$       D  $100 \text{ ms div}^{-1}$

- 1 A car is travelling with uniform acceleration along a straight road. The road has marker posts every 100 m. When the car passes one post, it has a speed of  $10 \text{ m s}^{-1}$  and, when it passes the next one, its speed is  $20 \text{ m s}^{-1}$ . 9702/01/M/J/04/Q.7

What is the car's acceleration?

- A**  $0.67 \text{ m s}^{-2}$       **B**  $1.5 \text{ m s}^{-2}$       **C**  $2.5 \text{ m s}^{-2}$       **D**  $6.0 \text{ m s}^{-2}$

- 2 What is meant by the weight of an object? 9702/1/O/N/02/Q.4

- A** the gravitational field acting on the object  
**B** the gravitational force acting on the object  
**C** the mass of the object multiplied by gravity  
**D** the object's mass multiplied by its acceleration

- 3 Two markers  $M_1$  and  $M_2$  are set up a vertical distance  $h$  apart. 9702/1/O/N/02/Q.3

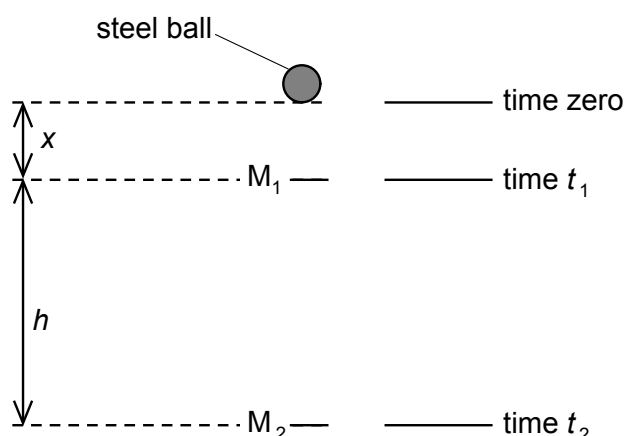

When a steel ball is released from rest from a point a distance  $x$  above  $M_1$ , it is found that the ball takes time  $t_1$  to reach  $M_1$  and time  $t_2$  to reach  $M_2$ .

Which expression gives the acceleration of the ball?

- A**  $\frac{2h}{t_2^2}$       **B**  $\frac{2h}{(t_2 + t_1)}$       **C**  $\frac{2h}{(t_2 - t_1)^2}$       **D**  $\frac{2h}{(t_2^2 - t_1^2)}$

- 4 The acceleration of free fall on a planet P is  $\frac{1}{6}$  of the acceleration of free fall on Earth. 9702/01/M/J/08/Q.7

The mass of a body on planet P is 30 kg.

What is its weight on planet P?

- A** 4.9 N      **B** 49 N      **C** 180 N      **D** 290 N

- 5 An object falls 10.0 m from rest before entering some water.

9702/01/O/N/04/Q.9

Assuming negligible air resistance, what is the time taken to reach the water and the speed with which the object reaches the water?

	time / ms	speed / $\text{m s}^{-1}$
<b>A</b>	1.02	10.0
<b>B</b>	1.02	14.0
<b>C</b>	1.43	10.0
<b>D</b>	1.43	14.0

- 6 A constant mass undergoes uniform acceleration.

9702/01/O/N/04/Q.10

Which of the following is a correct statement about the resultant force acting on the mass?

- A** It increases uniformly with respect to time.  
**B** It is constant but not zero.  
**C** It is proportional to the displacement from a fixed point.  
**D** It is proportional to the velocity.
- 7 An experiment is done to measure the acceleration of free fall of a body from rest.

9702/01/M/J/06/Q.7

Which measurements are needed?

- A** the height of fall and the time of fall  
**B** the height of fall and the weight of the body  
**C** the mass of the body and the height of fall  
**D** the mass of the body and the time of fall
- 8 A force  $F$  is applied to a freely moving object. At one instant of time, the object has velocity  $v$  and acceleration  $a$ .

9702/01/O/N/06/Q.10

Which quantities **must** be in the same direction?

- A**  $a$  and  $v$  only  
**B**  $a$  and  $F$  only  
**C**  $v$  and  $F$  only  
**D**  $v$ ,  $F$  and  $a$

- 9 Two markers  $M_1$  and  $M_2$  are set up a vertical distance  $h$  apart.

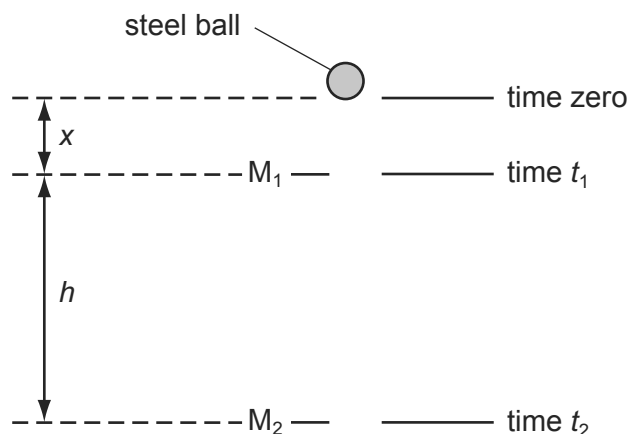

A steel ball is released at time zero from a point a distance  $x$  above  $M_1$ . The ball reaches  $M_1$  at time  $t_1$  and reaches  $M_2$  at time  $t_2$ . The acceleration of the ball is constant.

Which expression gives the acceleration of the ball?

- A**  $\frac{2h}{t_2^2}$       **B**  $\frac{2h}{(t_2 + t_1)}$       **C**  $\frac{2h}{(t_2 - t_1)^2}$       **D**  $\frac{2h}{(t_2^2 - t_1^2)}$

- 10 A stone is dropped from the top of a tower of height 40 m. The stone falls from rest and air resistance is negligible.

9702/01/M/J/07/Q8

What time is taken for the stone to fall the last 10 m to the ground?

- A** 0.38 s      **B** 1.4 s      **C** 2.5 s      **D** 2.9 s

- 11 What is meant by the weight of an object?

9702/01/M/J/07/Q9

- A** the gravitational field acting on the object  
**B** the gravitational force acting on the object  
**C** the mass of the object multiplied by gravity  
**D** the object's mass multiplied by its acceleration

- 12 The symbol  $g$  represents the acceleration of free fall.

9702/01/O/N/07/Q7

Which of these statements is correct?

- A**  $g$  is gravity.  
**B**  $g$  is reduced by air resistance.  
**C**  $g$  is the ratio weight / mass.  
**D**  $g$  is the weight of an object.

- 13 An object accelerates in a direction that is always perpendicular to its motion.

9702/01/M/J/08/Q6

What is the effect, if any, of the acceleration on the object's speed and direction?

	speed	direction
<b>A</b>	changes	changes
<b>B</b>	changes	constant
<b>C</b>	constant	changes
<b>D</b>	constant	constant

- 14 On a particular railway, a train driver applies the brake of the train at a yellow signal, a distance of 1.0 km from a red signal, where it stops.

9702/11/O/N/09/Q5

The maximum deceleration of the train is  $0.2 \text{ m s}^{-2}$ .

Assuming uniform deceleration, what is the maximum safe speed of the train at the yellow signal?

- A**  $20 \text{ m s}^{-1}$       **B**  $40 \text{ m s}^{-1}$       **C**  $200 \text{ m s}^{-1}$       **D**  $400 \text{ m s}^{-1}$
- 15 Four students each made a series of measurements of the acceleration of free fall  $g$ . The table shows the results obtained.

9702/01/M/J/08/Q5

Which set of results could be described as precise but **not** accurate?

	$g/\text{m s}^{-2}$			
<b>A</b>	9.81	9.79	9.84	9.83
<b>B</b>	9.81	10.12	9.89	8.94
<b>C</b>	9.45	9.21	8.99	8.76
<b>D</b>	8.45	8.46	8.50	8.41

- 16 Which statement about a ball that strikes a tennis racket and rebounds is **always** correct?

9702/12/O/N/09/Q7

- A** Total kinetic energy of the ball is conserved.  
**B** Total kinetic energy of the system is conserved.  
**C** Total momentum of the ball is conserved.  
**D** Total momentum of the system is conserved.

- 17 A ball is thrown horizontally in still air from the top of a very tall building. The ball is affected by air resistance. 9702/11/O/N/10/Q7

What happens to the horizontal and to the vertical components of the ball's velocity?

	horizontal component of velocity	vertical component of velocity
<b>A</b>	decreases to zero	increases at a constant rate
<b>B</b>	decreases to zero	increases to a constant value
<b>C</b>	remains constant	increases at a constant rate
<b>D</b>	remains constant	increases to a constant value

- 18 In order that a train can stop safely, it will always pass a signal showing a yellow light before it reaches a signal showing a red light. Drivers apply the brake at the yellow light and this results in a uniform deceleration to stop exactly at the red light. 9702/11/O/N/10/Q9

The distance between the red and yellow lights is  $x$ .

What must be the minimum distance between the lights if the train speed is increased by 20 %, without changing the deceleration of the trains?

- A**  $1.20x$       **B**  $1.25x$       **C**  $1.44x$       **D**  $1.56x$
- 19 The gravitational field strength on the surface of planet P is one tenth of that on the surface of planet Q. 9702/11/O/N/10/Q10

On the surface of P, a body has a mass of 1.0 kg and a weight of 1.0 N.

What are the mass and weight of the same body on the surface of planet Q?

	mass on Q/kg	weight on Q/N
<b>A</b>	1.0	0.1
<b>B</b>	1.0	10
<b>C</b>	10	10
<b>D</b>	10	100

- 20 A football is dropped from the top of a three-storey building. It falls through air until it reaches the ground. 9702/12/O/N/10/Q6

What remains constant throughout the fall?

- A** acceleration of the football  
**B** air resistance on the football  
**C** velocity of the football  
**D** weight of the football

- 21 A moving body undergoes uniform acceleration while travelling in a straight line between points X, Y and Z. The distances XY and YZ are both 40 m. The time to travel from X to Y is 12 s and from Y to Z is 6.0 s.

9702/12/O/N/10/Q8

What is the acceleration of the body?

- A**  $0.37 \text{ ms}^{-2}$       **B**  $0.49 \text{ ms}^{-2}$       **C**  $0.56 \text{ ms}^{-2}$       **D**  $1.1 \text{ ms}^{-2}$

- 22 A bullet is fired horizontally with speed  $v$  from a rifle. For a short time  $t$  after leaving the rifle, the only force affecting its motion is gravity. The acceleration of free fall is  $g$ .

9702/12/M/J/11/Q6

Which expression gives the value of  $\frac{\text{the horizontal distance travelled in time } t}{\text{the vertical distance travelled in time } t}$ ?

- A**  $\frac{vt}{g}$       **B**  $\frac{v}{gt}$       **C**  $\frac{2vt}{g}$       **D**  $\frac{2v}{gt}$

- 23 A body has a weight of 58.9 N when on the Earth. On the Moon, the acceleration of free fall is  $1.64 \text{ ms}^{-2}$ .

9702/11/M/J/11/Q8

What are the weight and the mass of the body when it is on the Moon?

	weight/N	mass/kg
<b>A</b>	9.85	1.00
<b>B</b>	9.85	6.00
<b>C</b>	58.9	1.00
<b>D</b>	58.9	6.00

- 24 A boy throws a ball vertically upwards. It rises to a maximum height, where it is momentarily at rest, and then falls back to his hands.

9702/11/O/N/11/Q8

Which row gives the acceleration of the ball at various stages in its motion? (Take vertically upwards as positive. Ignore air resistance.)

	rising	at maximum height	falling
<b>A</b>	$-9.81 \text{ ms}^{-2}$	0	$+9.81 \text{ ms}^{-2}$
<b>B</b>	$-9.81 \text{ ms}^{-2}$	$-9.81 \text{ ms}^{-2}$	$-9.81 \text{ ms}^{-2}$
<b>C</b>	$+9.81 \text{ ms}^{-2}$	$+9.81 \text{ ms}^{-2}$	$+9.81 \text{ ms}^{-2}$
<b>D</b>	$+9.81 \text{ ms}^{-2}$	0	$-9.81 \text{ ms}^{-2}$



- 25 A body has a weight of 58.9 N when on the Earth. On the Moon, the acceleration of free fall is  $1.64 \text{ ms}^{-2}$ .  
9702/13/M/J/11/Q6

What are the weight and the mass of the body when it is on the Moon?

	weight/N	mass/kg
<b>A</b>	9.85	1.00
<b>B</b>	9.85	6.00
<b>C</b>	58.9	1.00
<b>D</b>	58.9	6.00

- 26 A body falling in a uniform gravitational field encounters air resistance. The air resistance increases until terminal velocity is reached.  
9702/11/O/N/11/Q9

Which factor does **not** affect its terminal velocity?

- A** the density of the air  
**B** the height from which the body falls  
**C** the mass of the body  
**D** the shape of the body
- 27 A stone of mass  $m$  is dropped from a tall building. There is significant air resistance. The acceleration of free fall is  $g$ .  
9702/12/O/N/11/Q7

When the stone reaches its terminal velocity, which information is correct?

	magnitude of the acceleration of the stone	magnitude of the force of gravity on the stone	magnitude of the force of air resistance on the stone
<b>A</b>	$g$	$mg$	$mg$
<b>B</b>	zero	$mg$	$mg$
<b>C</b>	zero	zero	$mg$
<b>D</b>	zero	zero	zero

- 28 A science museum designs an experiment to show the fall of a feather in a vertical glass vacuum tube.  
9702/12/O/N/12/Q8

The time of fall from rest is to be close to 0.5 s.

What length of tube is required?

- A** 1.3 m      **B** 2.5 m      **C** 5.0 m      **D** 10.0 m

- 29 In an experiment to determine the acceleration of free fall using a falling body, what would lead to a value that is too large?

9702/11/M/J/12/Q6

- A air resistance
- B dimensions of the body are too large
- C measured distance longer than true distance
- D measured time longer than true time

- 30 The diagram shows a laboratory experiment in which a feather falls from rest in a long evacuated vertical tube of length  $L$ .

9702/11/M/J/12/Q8

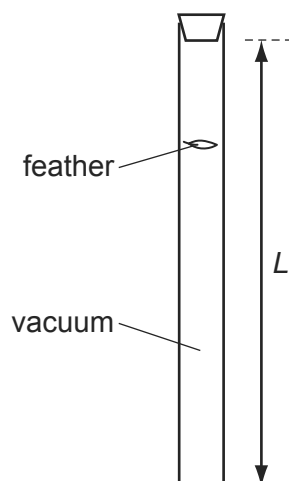

The feather takes time  $T$  to fall from the top to the bottom of the tube.

How far will the feather have fallen from the top of the tube in time  $0.50 T$ ?

- A  $0.13 L$
- B  $0.25 L$
- C  $0.38 L$
- D  $0.50 L$

- 31 The speed of a car is calculated from measurements of the distance travelled and the time taken.

9702/12/O/N/12/Q7

The distance is measured as 200 m, with an uncertainty of  $\pm 2$  m.

The time is measured as 10.0 s, with an uncertainty of  $\pm 0.2$  s.

What is the percentage uncertainty in the calculated speed?

- A  $\pm 0.5\%$
- B  $\pm 1\%$
- C  $\pm 2\%$
- D  $\pm 3\%$

- 32 A ball is thrown vertically in air.

9702/11/O/N/12/Q9

Neglecting air resistance, which property of the ball can **never** be zero at any time during the flight?

- A acceleration
- B kinetic energy
- C speed
- D velocity

- 33 Two markers  $M_1$  and  $M_2$  are set up a vertical distance  $h$  apart.

9702/12/M/J/12/Q8

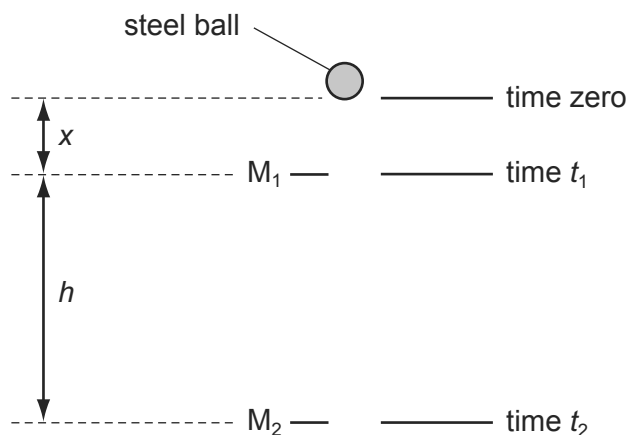

A steel ball is released at time zero from a point a distance  $x$  above  $M_1$ . The ball reaches  $M_1$  at time  $t_1$  and reaches  $M_2$  at time  $t_2$ . The acceleration of the ball is constant.

Which expression gives the acceleration of the ball?

- A  $\frac{2h}{t_2^2}$       B  $\frac{2h}{(t_2 + t_1)}$       C  $\frac{2h}{(t_2 - t_1)^2}$       D  $\frac{2h}{(t_2^2 - t_1^2)}$
- 34 The diagram shows a laboratory experiment in which a feather falls from rest in a long evacuated vertical tube of length  $L$ .

9702/13/M/J/12/Q9

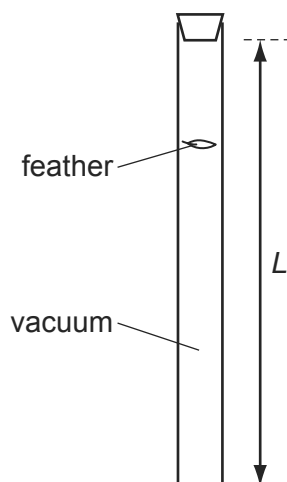

The feather takes time  $T$  to fall from the top to the bottom of the tube.

How far will the feather have fallen from the top of the tube in time  $0.50T$ ?

- A  $0.13L$       B  $0.25L$       C  $0.38L$       D  $0.50L$
- 35 A bicycle brakes so that it undergoes uniform deceleration from a speed of  $8\text{ m s}^{-1}$  to  $6\text{ m s}^{-1}$  over a distance of  $7\text{ m}$ .

9702/13/O/N/12/Q8

If the deceleration of the bicycle remains constant, what further distance will it travel before coming to rest?

- A  $7\text{ m}$       B  $9\text{ m}$       C  $16\text{ m}$       D  $21\text{ m}$

- 36 A body is released from rest and falls vertically in air of constant density. 9702/11/M/J/13/Q7

Which statement about the motion of the falling body is correct?

- A** As it accelerates, its weight decreases so that its acceleration decreases until it travels with constant velocity.
- B** It accelerates initially at  $9.8 \text{ m s}^{-2}$  but the drag force increases so its acceleration decreases.
- C** Its velocity increases at a constant rate until its velocity becomes constant.
- D** The drag force of the air increases continually and eventually the velocity decreases.
- 37 A goods train passes through a station at a steady speed of  $10 \text{ m s}^{-1}$ . An express train is at rest at the station. The express train leaves the station with a uniform acceleration of  $0.5 \text{ m s}^{-2}$  just as the goods train goes past. Both trains move in the same direction on straight, parallel tracks. 9702/11/M/J/13/Q8

How much time passes before the express train overtakes the goods train?

- A** 6 s                      **B** 10 s                      **C** 20 s                      **D** 40 s

- 38 The diagram shows an arrangement to stop trains that are travelling too fast. 9702/12/M/J/13/Q7



Trains coming from the left travel at a speed of  $50 \text{ m s}^{-1}$ . At marker 1, the driver must apply the brakes so that the train decelerates uniformly in order to pass marker 2 at no more than  $10 \text{ m s}^{-1}$ .

The train carries a detector that notes the times when the train passes each marker and will apply an emergency brake if the time between passing marker 1 and marker 2 is less than 20 s.

How far from marker 2 should marker 1 be placed?

- A** 200 m                      **B** 400 m                      **C** 500 m                      **D** 600 m
- 39 An aeroplane travels at an average speed of  $600 \text{ km h}^{-1}$  on an outward flight and at  $400 \text{ km h}^{-1}$  on the return flight over the same distance. 9702/11/O/N/13/Q8

What is the average speed of the whole flight?

- A**  $111 \text{ m s}^{-1}$                       **B**  $167 \text{ m s}^{-1}$                       **C**  $480 \text{ km h}^{-1}$                       **D**  $500 \text{ km h}^{-1}$

- 40 One object moves directly from P to R.

9702/11/O/N/13/Q6



In a shorter time, a second object moves from P to Q to R.

Which statement about the two objects is correct for the journey from P to R?

- A** They have the same average speed.  
**B** They have the same average velocity.  
**C** They have the same displacement.  
**D** They travel the same distance.
- 41 On a particular railway, a train driver applies the brake of the train at a yellow signal, a distance of 1.0 km from a red signal, where the train stops.

9702/13/O/N/13/Q8

The maximum deceleration of the train is  $0.20 \text{ m s}^{-2}$ .

Assuming uniform deceleration, what is the maximum safe speed of the train at the yellow signal?

- A**  $14 \text{ m s}^{-1}$       **B**  $20 \text{ m s}^{-1}$       **C**  $40 \text{ m s}^{-1}$       **D**  $400 \text{ m s}^{-1}$
- 42 A person, travelling on a motorway a total distance of 200 km, travels the first 90 km at an average speed of  $80 \text{ km h}^{-1}$ .

9702/13/O/N/13/Q9

Which average speed must be obtained for the rest of the journey if the person is to reach the destination in a total time of 2 hours 0 minutes?

- A**  $110 \text{ km h}^{-1}$       **B**  $120 \text{ km h}^{-1}$       **C**  $122 \text{ km h}^{-1}$       **D**  $126 \text{ km h}^{-1}$
- 43 A mass accelerates uniformly when the resultant force acting on it
- A** is zero.  
**B** is constant but not zero.  
**C** increases uniformly with respect to time.  
**D** is proportional to the displacement from a fixed point.

9702/13/O/N/13/Q12

- 44 An object is thrown with velocity  $5.2 \text{ m s}^{-1}$  vertically upwards on the Moon. The acceleration due to gravity on the Moon is  $1.62 \text{ m s}^{-2}$ . 9702/11/M/J/14/Q7

What is the time taken for the object to return to its starting point?

- A** 2.5 s      **B** 3.2 s      **C** 4.5 s      **D** 6.4 s

- 45 A radio-controlled toy car travels along a straight line for a time of 15 s. 9702/12/M/J/14/Q6

The variation with time  $t$  of the velocity  $v$  of the car is shown below.

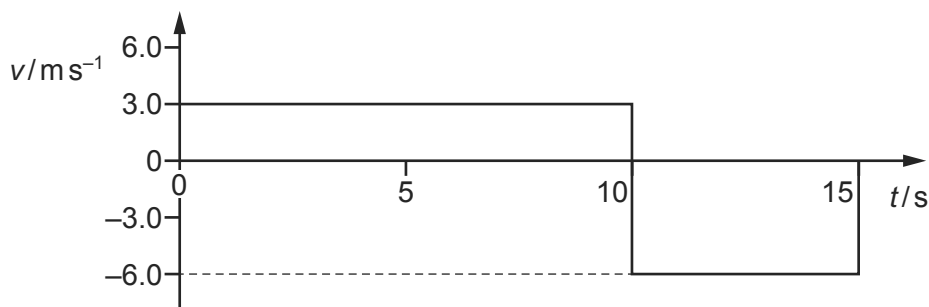

What is the average velocity of the toy car for the journey shown by the graph?

- A**  $-1.5 \text{ m s}^{-1}$       **B**  $0.0 \text{ m s}^{-1}$       **C**  $4.0 \text{ m s}^{-1}$       **D**  $4.5 \text{ m s}^{-1}$

- 46 In a cathode-ray tube, an electron is accelerated uniformly in a straight line from a speed of  $4 \times 10^3 \text{ m s}^{-1}$  to  $2 \times 10^7 \text{ m s}^{-1}$  over a distance of 10 mm. 9702/13/M/J/14/Q8

What is the acceleration of the electron?

- A**  $2 \times 10^3 \text{ m s}^{-2}$   
**B**  $2 \times 10^6 \text{ m s}^{-2}$   
**C**  $2 \times 10^{13} \text{ m s}^{-2}$   
**D**  $2 \times 10^{16} \text{ m s}^{-2}$

- 47 An experiment is performed to measure the acceleration of free fall  $g$ . A body falls between two fixed points. The four measurements shown below are taken. 9702/13/M/J/14/Q7

Which measurement is **not** required for the calculation of  $g$ ?

- A** the distance fallen by the body  
**B** the initial velocity of the body  
**C** the mass of the body  
**D** the time taken for the body to fall

- 48 In an experiment to determine the acceleration of free fall  $g$ , a ball-bearing is held by an electromagnet. When the current to the electromagnet is switched off, a clock starts and the ball-bearing falls. After falling a distance  $h$ , the ball-bearing strikes a switch to stop the clock which measures the time  $t$  of the fall. 9702/13/O/N/14/Q6

Which expression can be used to calculate the value of  $g$ ?

- A  $\frac{ht^2}{2}$       B  $\frac{th^2}{2}$       C  $\sqrt{\frac{2t}{h^2}}$       D  $\frac{2h}{t^2}$

- 49 The acceleration of free fall on the Moon is one-sixth of that on Earth. 9702/11/O/N/14/Q5

On Earth it takes time  $t$  for a stone to fall from rest a distance of 2 m.

What is the time taken for a stone to fall from rest a distance of 2 m on the Moon?

- A  $6t$       B  $\frac{t}{6}$       C  $t\sqrt{6}$       D  $\frac{t}{\sqrt{6}}$

- 50 In an experiment to determine the acceleration of free fall  $g$ , a ball bearing is held by an electromagnet. When the current to the electromagnet is switched off, a clock starts and the ball bearing falls. After falling a distance  $h$ , the ball bearing strikes a switch to stop the clock which measures the time  $t$  of the fall. 9702/12/M/J/15/Q7

If systematic errors cause  $t$  and  $h$  to be measured incorrectly, which error **must** cause  $g$  to appear greater than  $9.81 \text{ m s}^{-2}$ ?

- A  $h$  measured as being **smaller** than it actually is and  $t$  is measured correctly  
 B  $h$  measured as being **smaller** than it actually is and  $t$  measured as being **larger** than it actually is  
 C  $h$  measured as being **larger** than it actually is and  $t$  measured as being **larger** than it actually is  
 D  $h$  is measured correctly and  $t$  measured as being **smaller** than it actually is

- 51 A body having uniform acceleration  $a$  increases its velocity from  $u$  to  $v$  in time  $t$ . 9702/11/M/J/15/Q9

Which expression would **not** give a correct value for the body's displacement during time  $t$ ?

- A  $ut + \frac{1}{2}at^2$   
 B  $vt - \frac{1}{2}at^2$   
 C  $\frac{(v+u)(v-u)}{2a}$   
 D  $\frac{(v-u)t}{2}$

- 52 A sprinter runs a 100 m race in a straight line. He accelerates from the starting block at a constant acceleration of  $2.5 \text{ m s}^{-2}$  to reach his maximum speed of  $10 \text{ m s}^{-1}$ . He maintains this speed until he crosses the finish line.

9702/12/M/J/15/Q9

Which time does it take the sprinter to run the race?

- A** 4 s                      **B** 10 s                      **C** 12 s                      **D** 20 s

- 53 An insect jumps with an initial vertical velocity of  $1.0 \text{ m s}^{-1}$ , reaching a maximum height of  $3.5 \times 10^{-2} \text{ m}$ . Assume the deceleration is uniform.

9702/11/M/J/15/Q8

What is the magnitude of the deceleration?

- A**  $3.6 \text{ m s}^{-2}$               **B**  $9.8 \text{ m s}^{-2}$               **C**  $14 \text{ m s}^{-2}$               **D**  $29 \text{ m s}^{-2}$



- 1 The graph relates to the motion of a falling body.

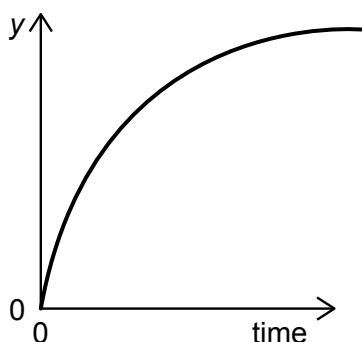

Which is a correct description of the graph?

- A  $y$  is distance and air resistance is negligible
  - B  $y$  is distance and air resistance is not negligible
  - C  $y$  is speed and air resistance is negligible
  - D  $y$  is speed and air resistance is not negligible
- 2 A stone is thrown upwards from the top of a cliff. After reaching its maximum height, it falls past the cliff-top and into the sea.

9702/1/M/J/02/Q8

The graph shows how the vertical velocity  $v$  of the stone varies with time  $t$  after being thrown upwards.  $R$  and  $S$  are the magnitudes of the areas of the two triangles.

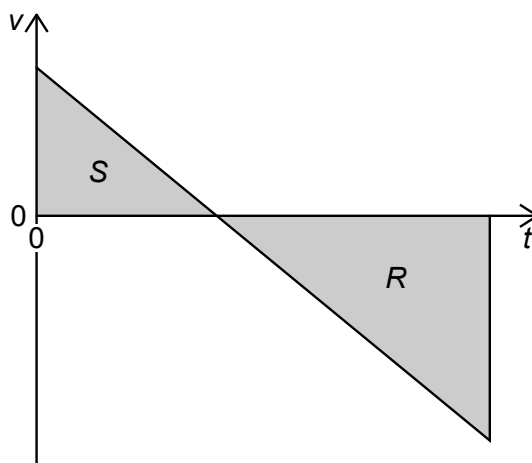

What is the height of the cliff-top above the sea?

- A  $R$
- B  $S$
- C  $R + S$
- D  $R - S$

- 3 Which graph represents the motion of a car that is travelling along a straight road with a uniformly increasing speed?

9702/1/M/J/02/Q7

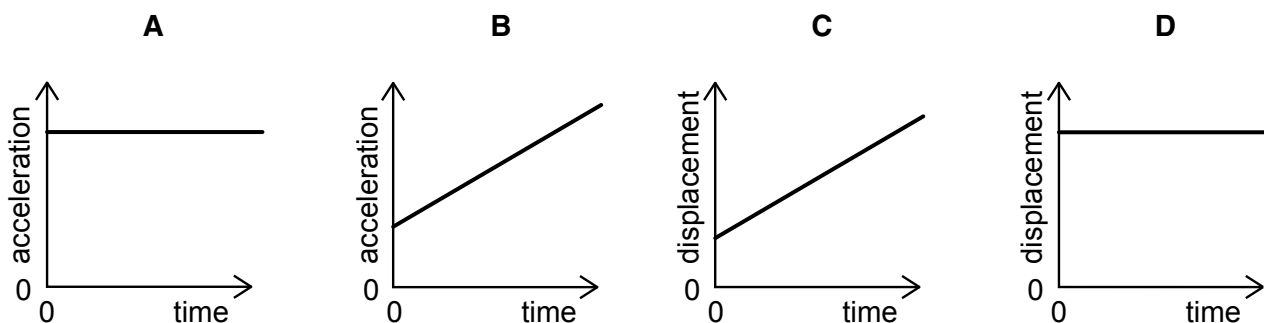

- 4 A ball is released from rest above a horizontal surface. The graph shows the variation with time of its velocity.

9702/1/M/J/03/Q9

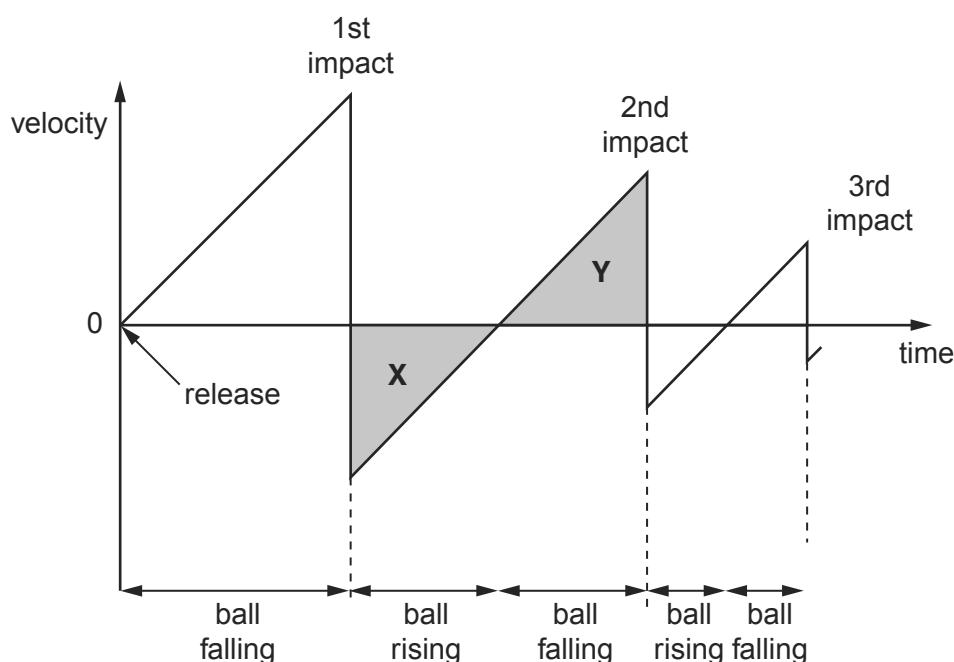

Areas **X** and **Y** are equal.

This is because

- A** the ball's acceleration is the same during its upward and downward motion.
- B** the speed at which the ball leaves the surface after an impact is equal to the speed at which it returns to the surface for the next impact.
- C** for one impact, the speed at which the ball hits the surface equals the speed at which it leaves the surface.
- D** the ball rises and falls through the same distance between impacts.

- 5 The graph of velocity against time for an object moving in a straight line is shown.

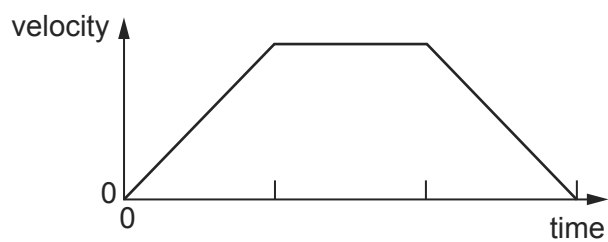

Which of the following is the corresponding graph of displacement against time?

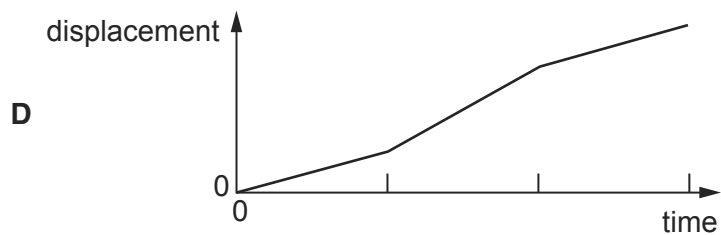
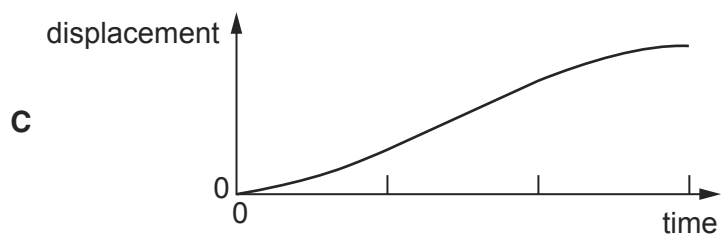
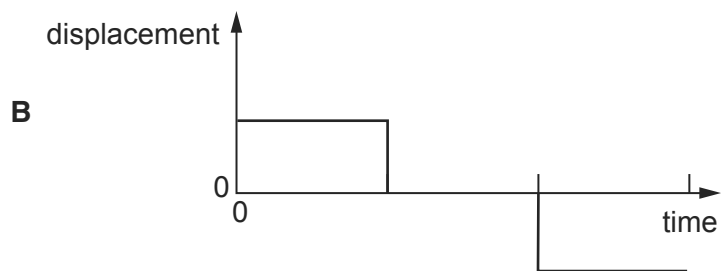
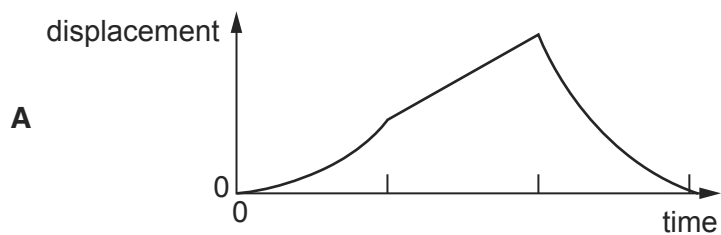

- 6 A tennis ball is released from rest at the top of a tall building.

9702/01/M/J/04/Q8

Which graph best represents the variation with time  $t$  of the acceleration  $a$  of the ball as it falls, assuming that the effects of air resistance are appreciable?

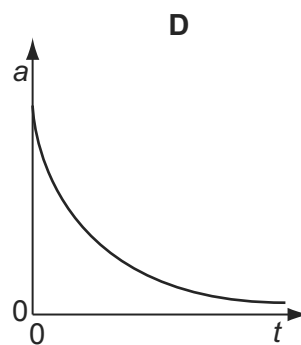
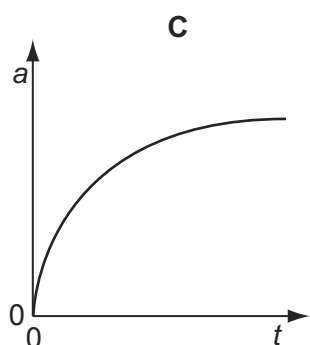
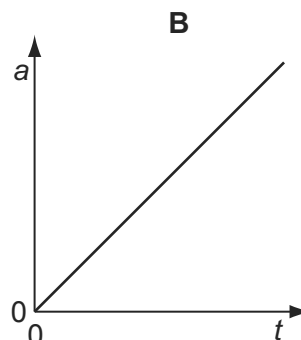
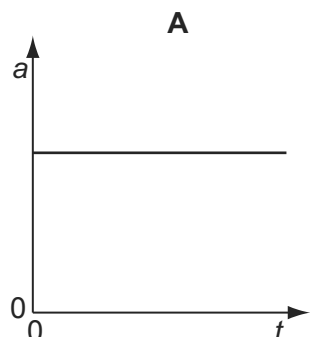

- 7 A particle is moving in a straight line with uniform acceleration.

9702/1/0/N/02/Q2

Which graph represents the motion of the particle?

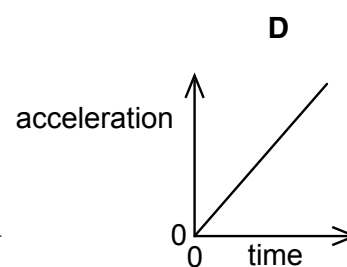
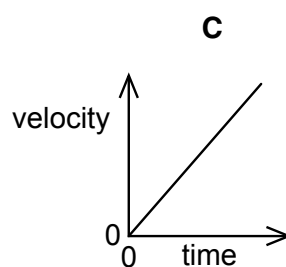
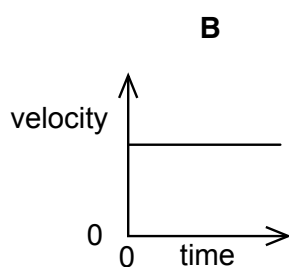
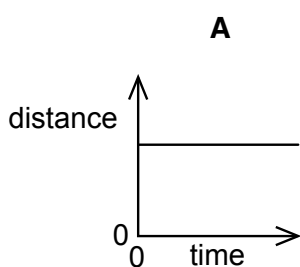

- 8 Which feature of a graph allows acceleration to be determined?

9702/01/M/J/05/Q6

- A** the area under a displacement-time graph
- B** the area under a velocity-time graph
- C** the slope of a displacement-time graph
- D** the slope of a velocity-time graph

- 9 An object is dropped from a great height and falls through air of uniform density.

9702/01/O/N/03/Q8

The acceleration of free fall is  $g$ .

Which graph could show the variation with time  $t$  of the acceleration  $a$  of the object?

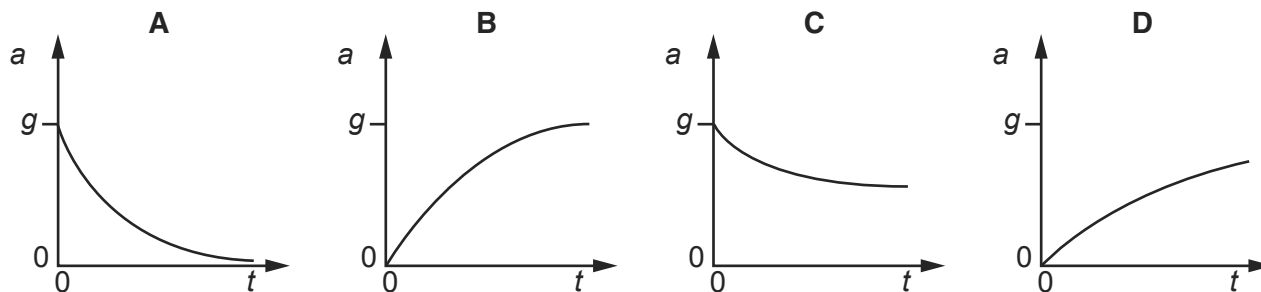

- 10 A body falls from rest in a vacuum near the Earth's surface. The variation with time  $t$  of its speed  $v$  is shown below.

9702/11/O/N/02/Q10

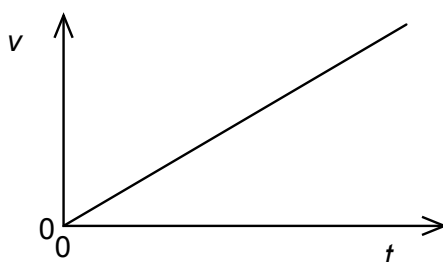

Which graph shows the variation with time  $t$  of the speed  $v$  of the same ball falling in air at the same place on Earth?

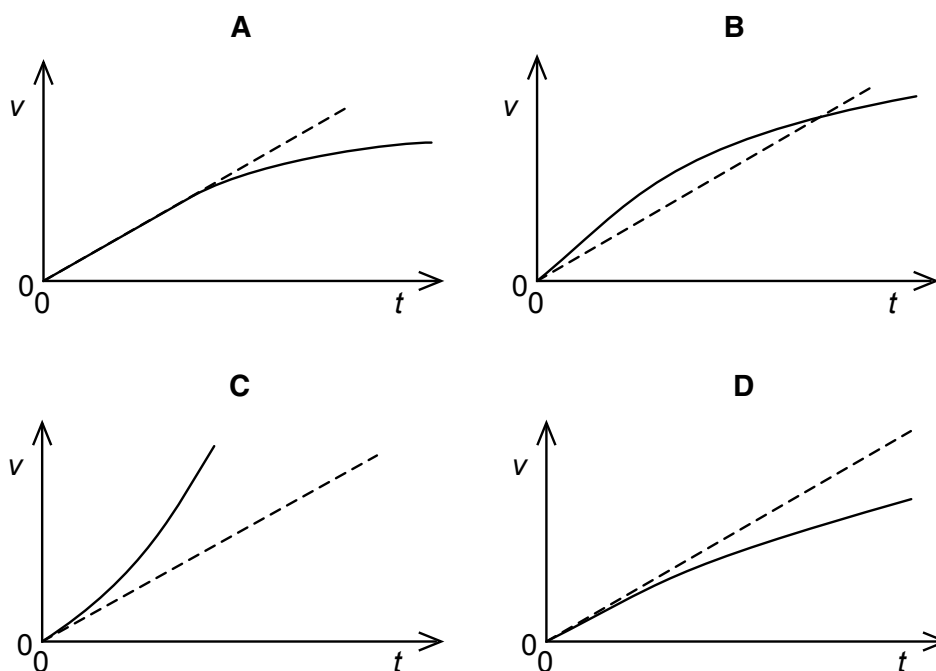

- 11 A car at rest in a traffic queue moves forward in a straight line and then comes to rest again. The graph shows the variation with time of its displacement.

9702/01/O/N/03/Q7

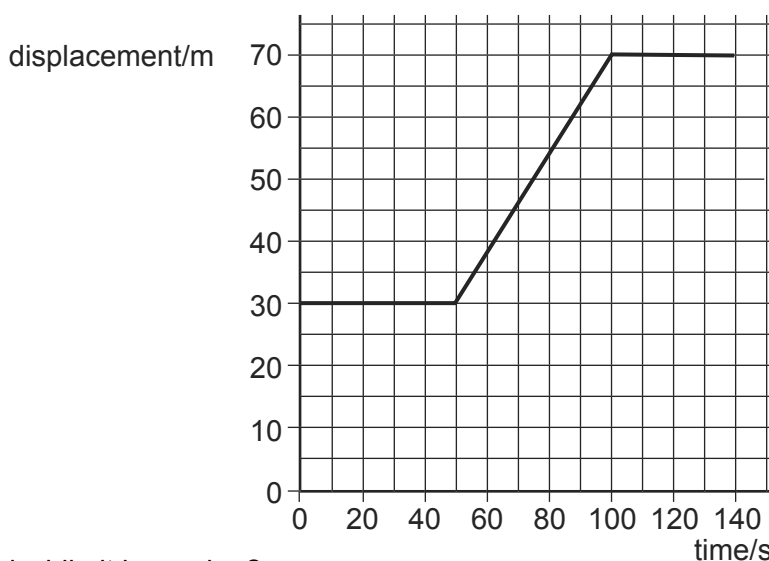

What is its speed while it is moving?

- A  $0.70 \text{ ms}^{-1}$       B  $0.80 \text{ ms}^{-1}$       C  $1.25 \text{ ms}^{-1}$       D  $1.40 \text{ ms}^{-1}$
- 12 When a car driver sees a hazard ahead, she applies the brakes as soon as she can and brings the car to rest. The graph shows how the speed  $v$  of the car varies with time  $t$  after the hazard is seen.

9702/01/O/N/04/Q8

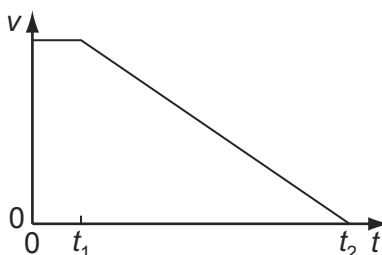

Which graph represents the variation with time  $t$  of the distance  $s$  travelled by the car after the hazard has been seen?

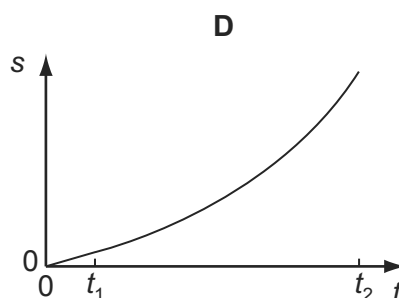
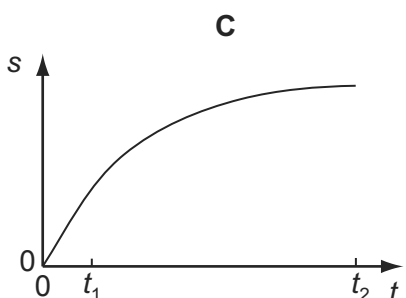
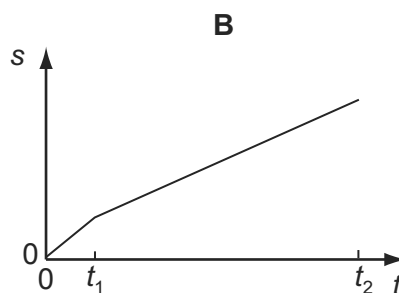
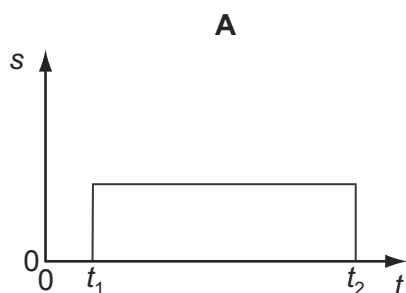

- 13 The diagram shows a velocity-time graph for a car.

9702/01/M/J/05/Q8

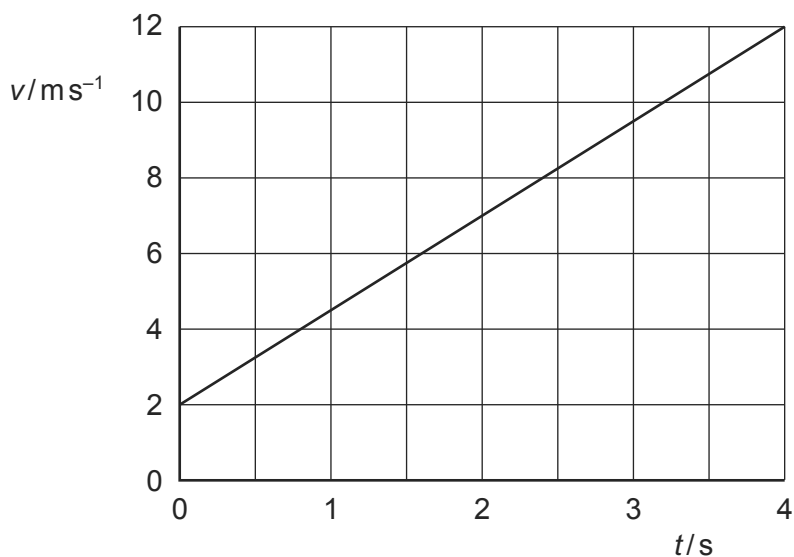

What is the distance travelled between time  $t = 0$  and  $t = 4$  s?

- A** 2.5 m      **B** 3.0 m      **C** 20 m      **D** 28 m
- 14 A boy throws a ball vertically upwards. It rises to a maximum height, where it is momentarily at rest, and falls back to his hands. 9702/01/M/J/05/Q7

Which of the following gives the acceleration of the ball at various stages in its motion? Take vertically upwards as positive. Neglect air resistance.

	rising	at maximum height	falling
<b>A</b>	$-9.81 \text{ ms}^{-2}$	0	$+9.81 \text{ ms}^{-2}$
<b>B</b>	$-9.81 \text{ ms}^{-2}$	$-9.81 \text{ ms}^{-2}$	$-9.81 \text{ ms}^{-2}$
<b>C</b>	$+9.81 \text{ ms}^{-2}$	$+9.81 \text{ ms}^{-2}$	$+9.81 \text{ ms}^{-2}$
<b>D</b>	$+9.81 \text{ ms}^{-2}$	0	$-9.81 \text{ ms}^{-2}$

- 15 A football is dropped from the top of a three-storey building. It falls through air until it reaches the ground. 9702/12/O/N/10/Q6

What remains constant throughout the fall?

- A** acceleration of the football  
**B** air resistance on the football  
**C** velocity of the football  
**D** weight of the football

- 16 A football is dropped from the top of a tall building.

9702/01/O/N/05/Q6

Which acceleration-time graph best represents the motion of the football through the air?

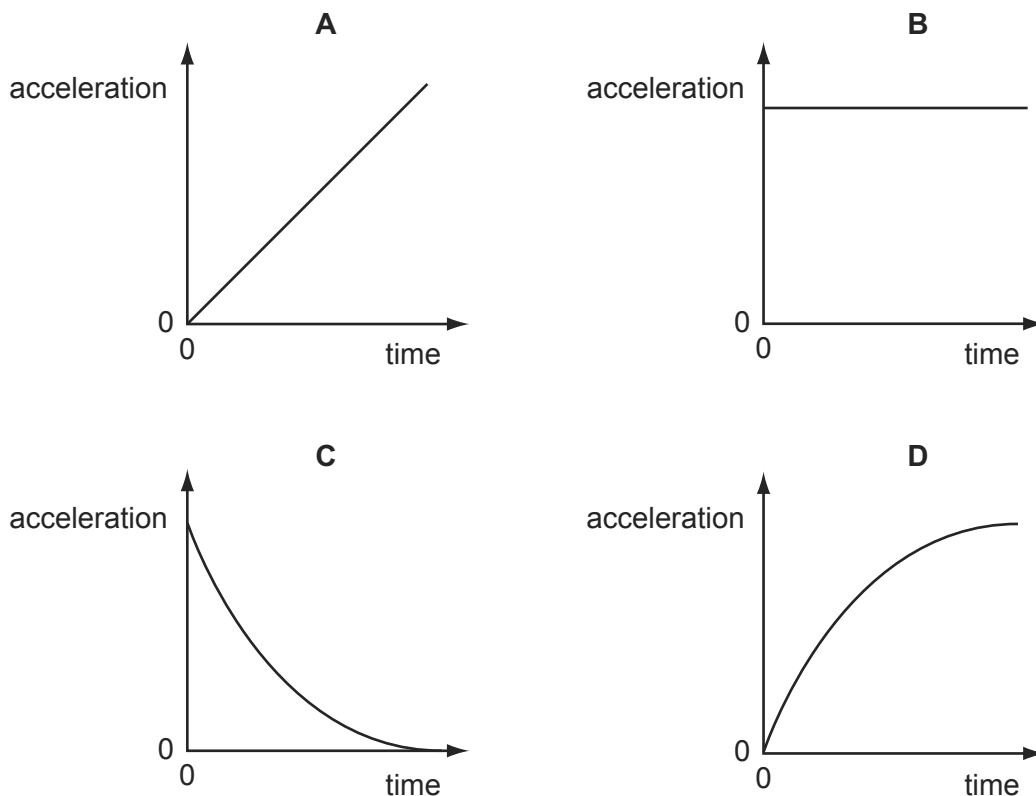

- 17 The diagram shows a velocity-time graph for a mass moving up and down on the end of a spring.

Which point represents the velocity of the mass when at the lowest point of its motion?

9702/01/M/J/06/Q9

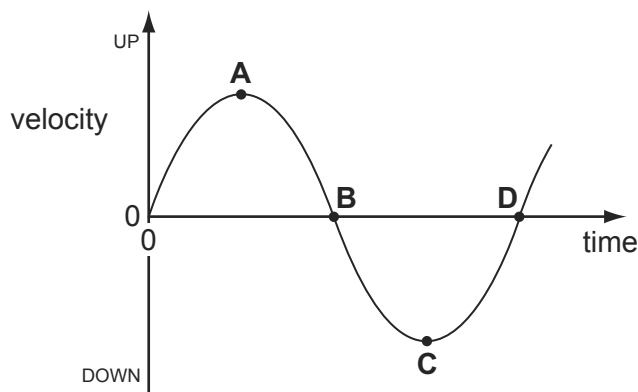

- 18 What gives the value of a body's acceleration?

9702/01/M/J/07/Q6

- A** the area under its displacement-time graph
- B** the area under its velocity-time graph
- C** the gradient of its displacement-time graph
- D** the gradient of its velocity-time graph



- 19 The velocity of an object during the first five seconds of its motion is shown on the graph.

9702/01/M/J/06/Q8

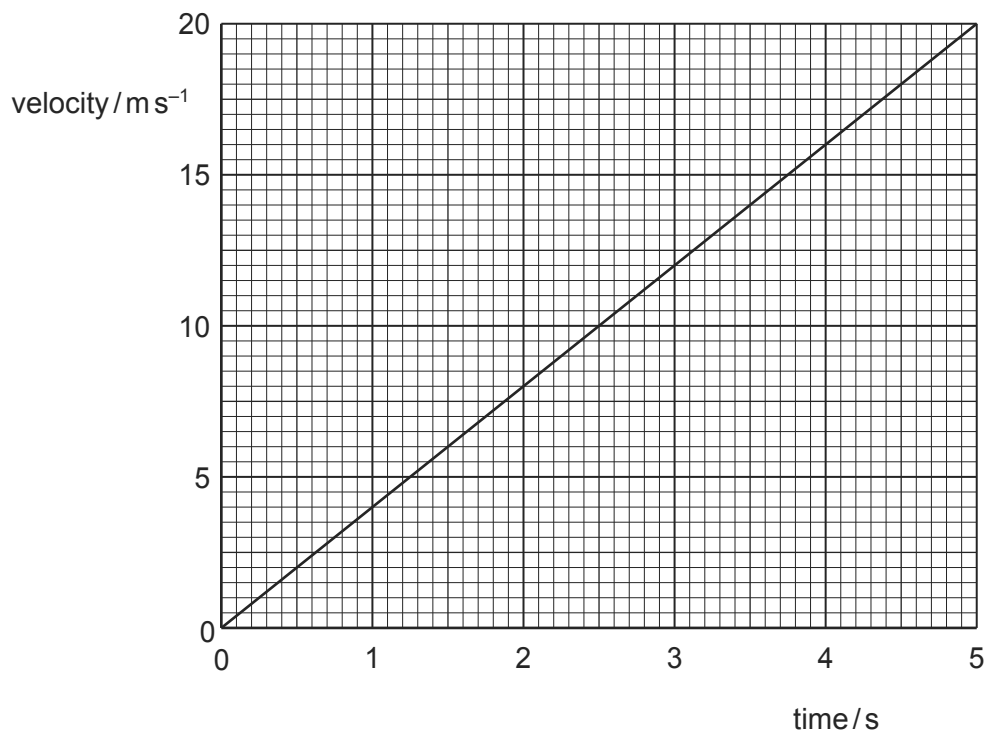

What is the distance travelled by the object in this time?

- A** 4 m                      **B** 20 m                      **C** 50 m                      **D** 100 m
- 20 A particle is moving in a straight line with uniform acceleration.

9702/01/O/N/06/Q7

Which graph represents the motion of the particle?

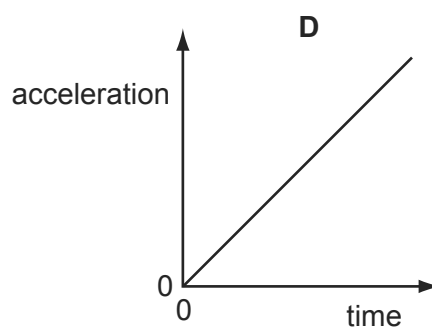
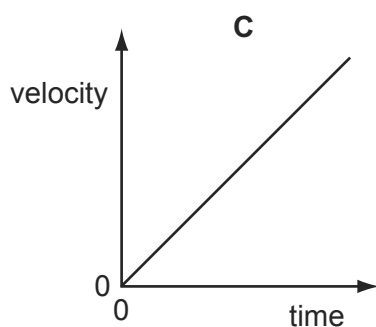
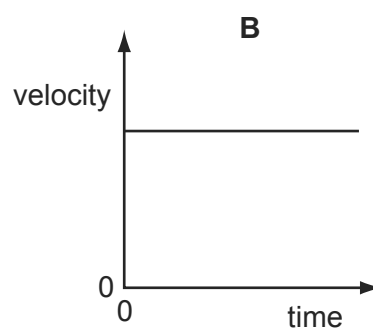
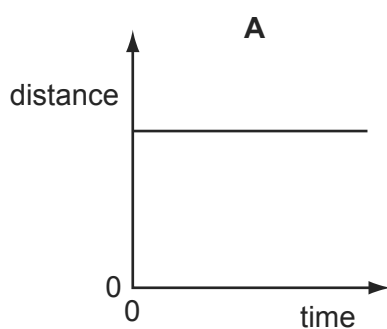

- 21 The graph shows velocity-time plots for two vehicles X and Y. The accelerations and distances travelled by the two vehicles can be estimated from these plots.

9702/01/O/N/06/Q8

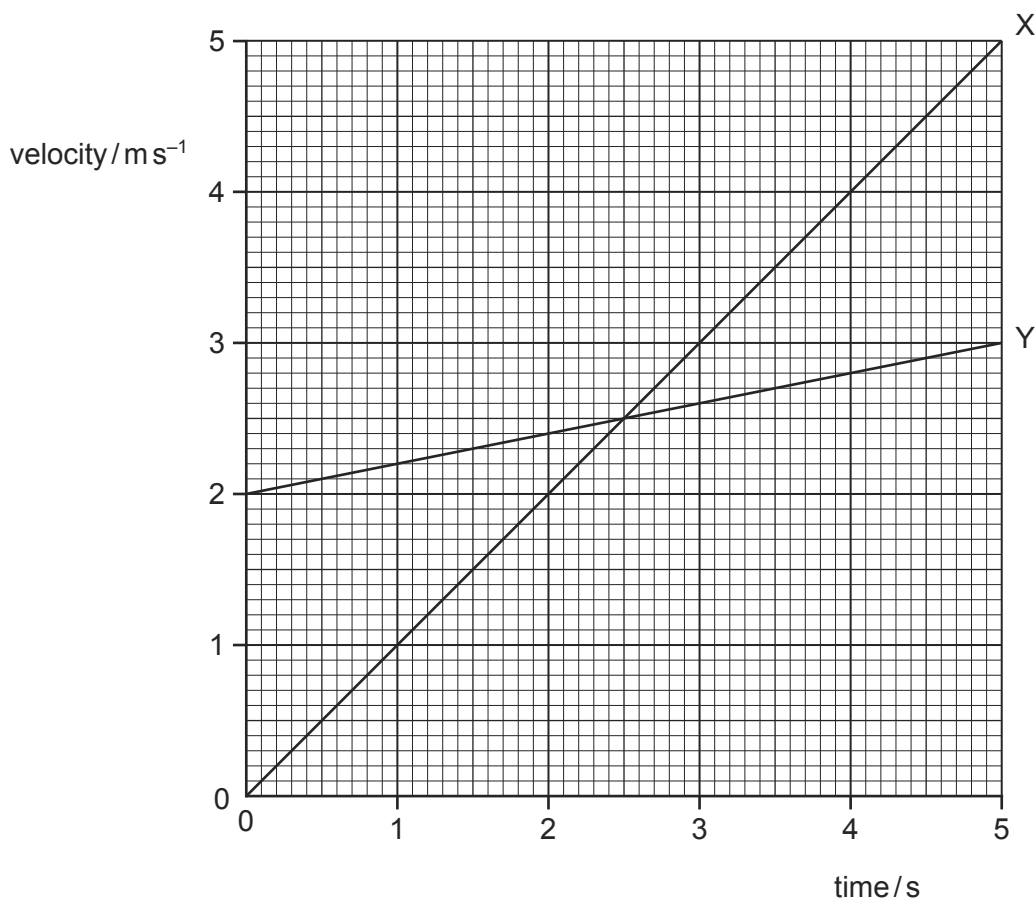

Which statement is correct?

- A** The accelerations of X and Y are the same at 2.5 s.  
**B** The initial acceleration of Y is greater than that of X.  
**C** The distance travelled by X is greater than that travelled by Y in the 5 s period.  
**D** The distances travelled by X and Y in the 5 s period are the same.
- 22 A small steel ball falls freely under gravity after being released from rest. 9702/13/M/J/10/Q13

Which graph best represents the variation of the height  $h$  of the ball with time  $t$ ?

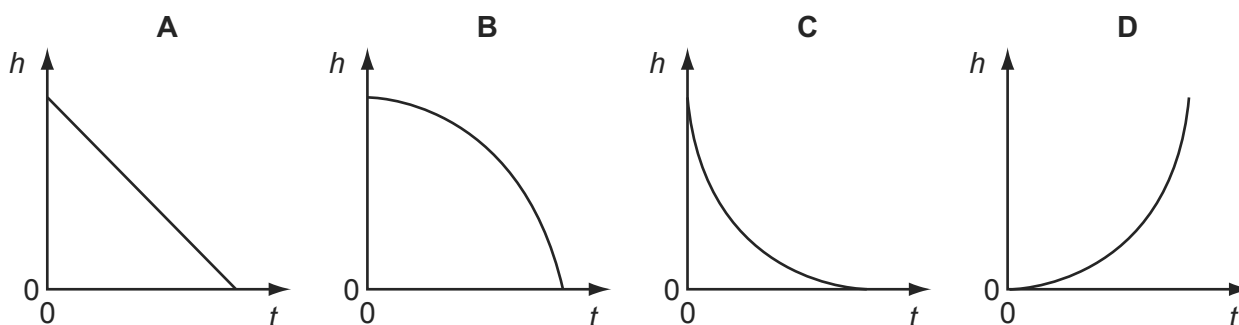

- 23 A car driver sharply presses down the accelerator when the traffic lights go green. The resultant horizontal force acting on the car varies with time as shown. 9702/01/O/N/05/Q8

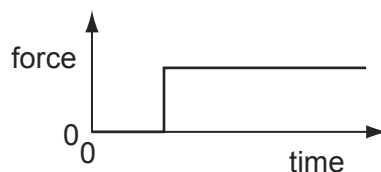

Which graph shows the variation with time of the speed of the car?

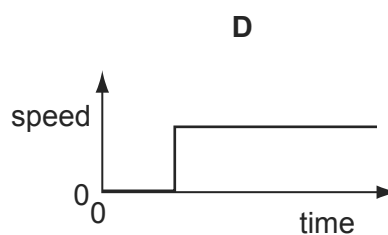
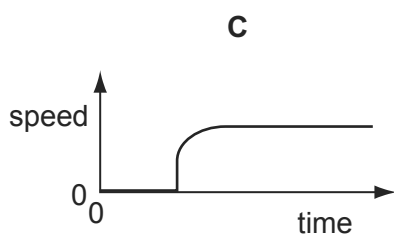
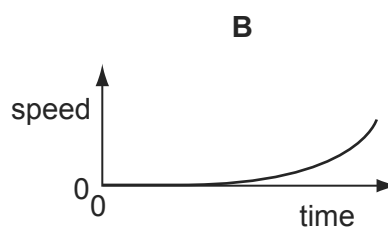
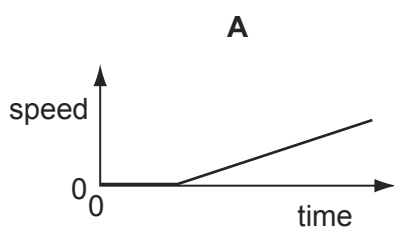

- 24 A particle moves along a straight line. A particular property  $K$  of the particle's motion is plotted against time. 9702/01/O/N/07/Q8

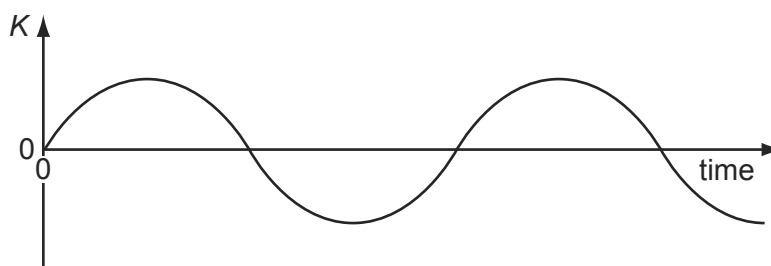

At any time, the slope of the graph is the acceleration of the particle.

What is the property  $K$ ?

- A** the displacement of the particle
- B** the distance travelled by the particle
- C** the speed of the particle
- D** the velocity of the particle

- 25 A stone is thrown vertically upwards. A student plots the variation with time of its velocity.

9702/01/O/N/07/Q9

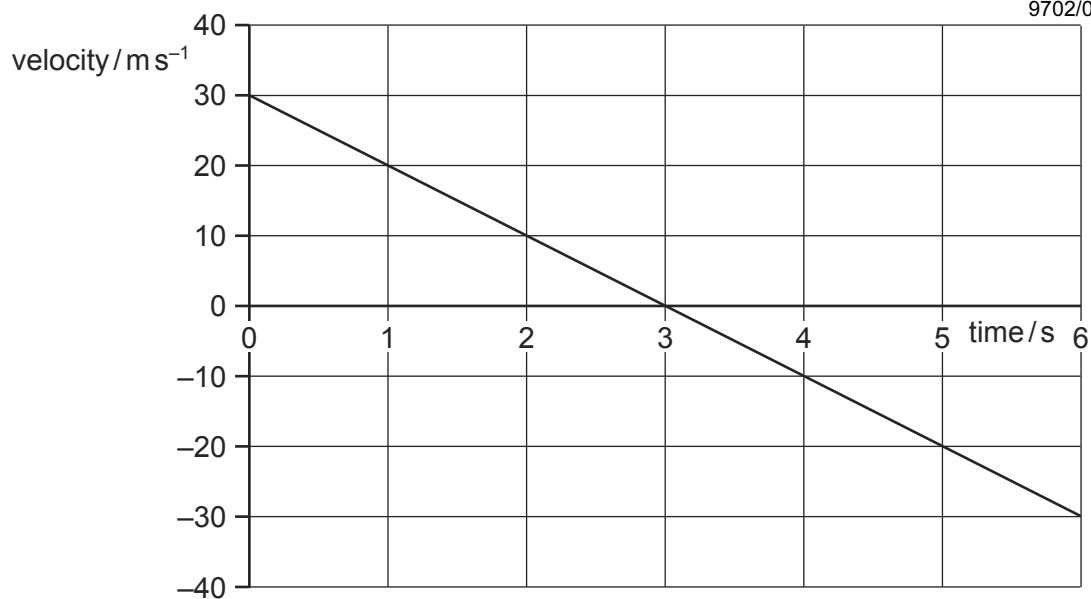

What is the vertical displacement of the stone from its starting point after 5 seconds?

- A** 20 m      **B** 25 m      **C** 45 m      **D** 65 m
- 26 A football is dropped from the top of a tall building.

9702/01/M/J/08/Q8

Which acceleration-time graph best represents the motion of the football through the air?

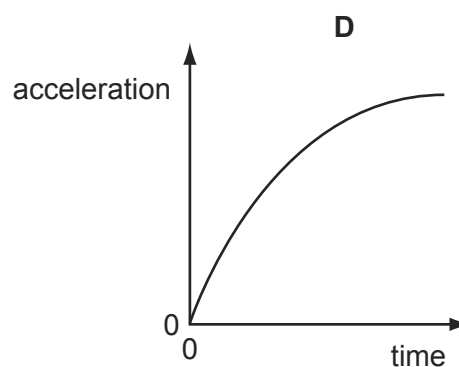
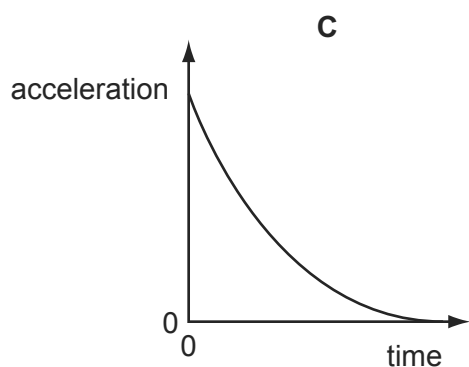
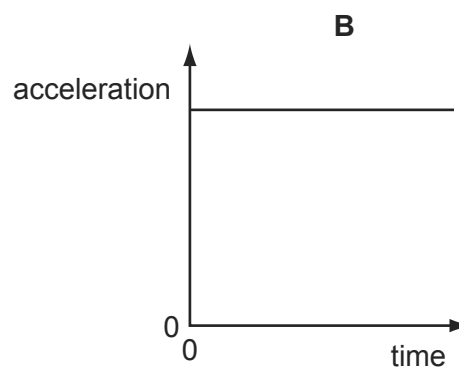
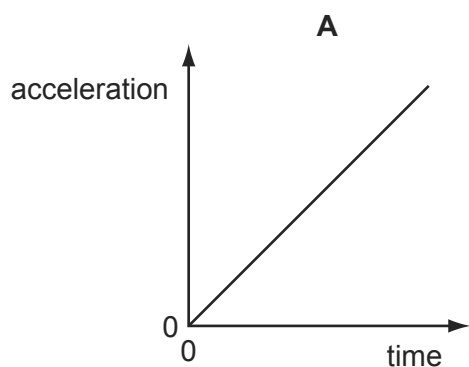

27 The diagram shows a velocity-time graph for a car.

9702/01/O/N/08/Q6

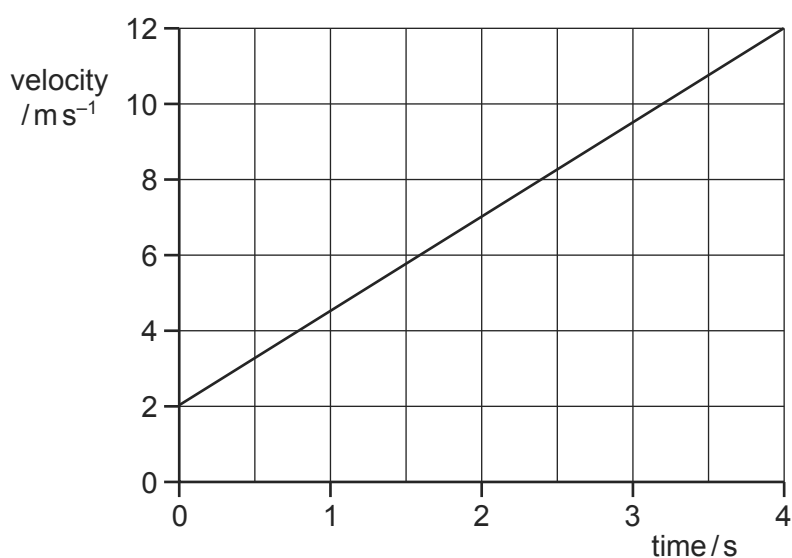

What is the distance travelled during the first 4.0 s?

- A** 2.5 m      **B** 3.0 m      **C** 20 m      **D** 28 m

28 Which displacement-time graph best represents the motion of a falling sphere, the initial acceleration of which eventually reduces until it begins to travel at constant terminal velocity?

9702/01/M/J/09/Q5

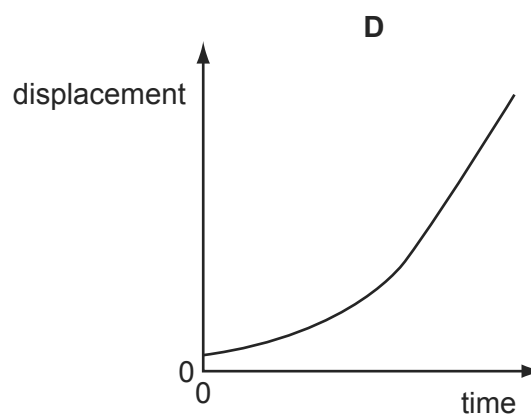
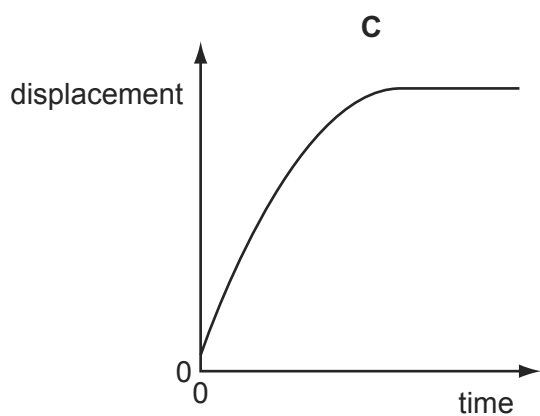
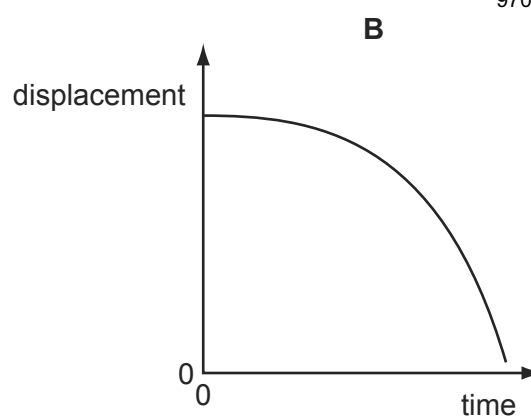
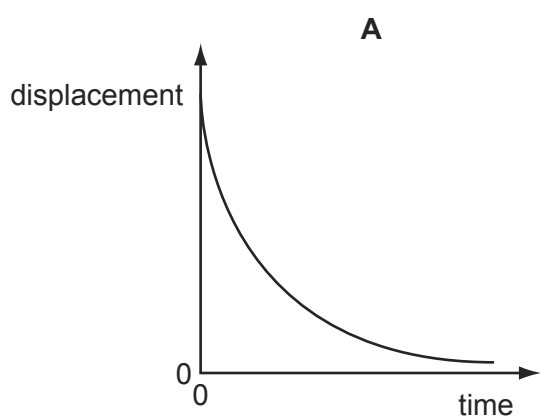

- 29 Which graph represents the motion of a car that is travelling along a straight road with a speed that increases uniformly with time?

9702/01/O/N/08/Q8

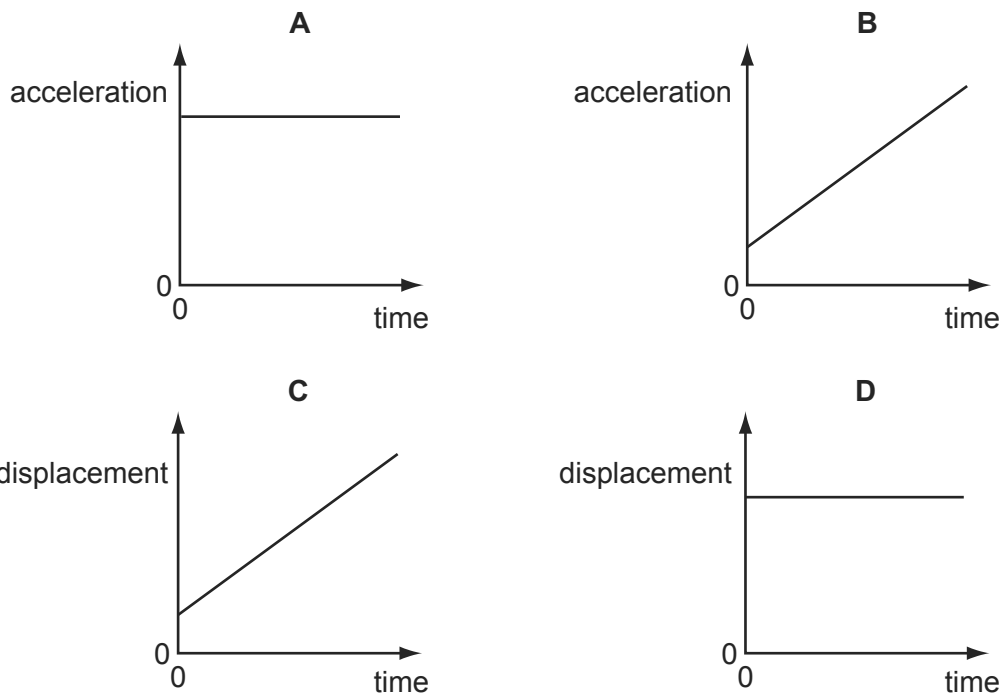

- 30 The diagram shows a velocity-time graph for a vehicle.

9702/11/M/J/10/Q8

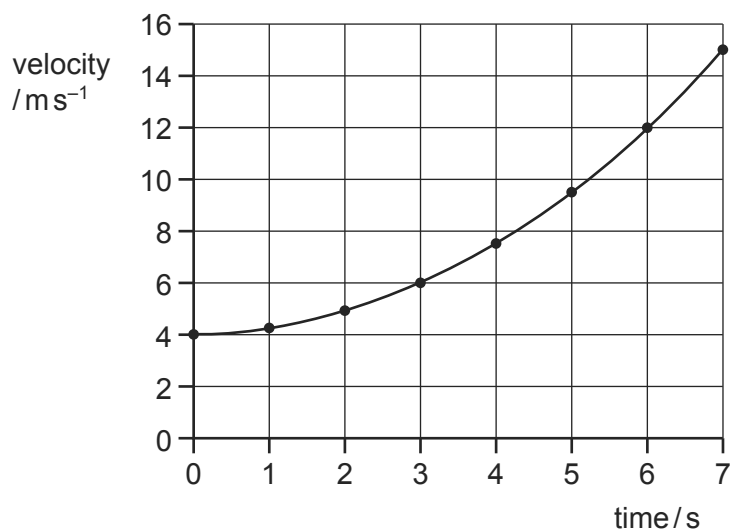

The vehicle, moving at  $4.0 \text{ ms}^{-1}$ , begins to accelerate at time = 0.

What is the vehicle's acceleration at time = 3.0 s?

- A**  $0.67 \text{ ms}^{-2}$     **B**  $1.0 \text{ ms}^{-2}$     **C**  $1.3 \text{ ms}^{-2}$     **D**  $2.0 \text{ ms}^{-2}$

- 31 When a car driver sees a hazard ahead, she applies the brakes as soon as she can and brings the car to rest.

9702/01/M/J/09/Q6

The graph shows how the speed  $v$  of the car varies with time  $t$  after she sees the hazard.

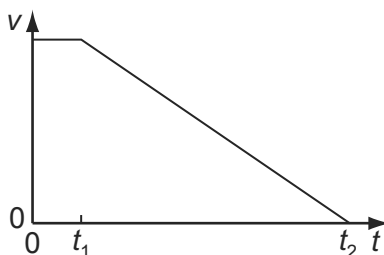

Which graph represents the variation with time  $t$  of the distance  $s$  travelled by the car after she has seen the hazard?

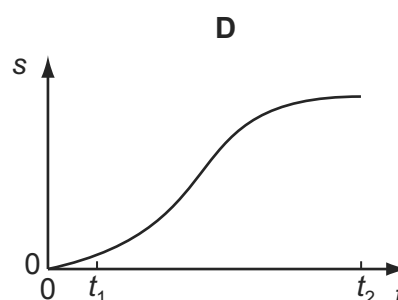
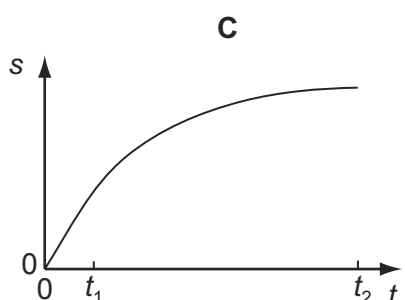
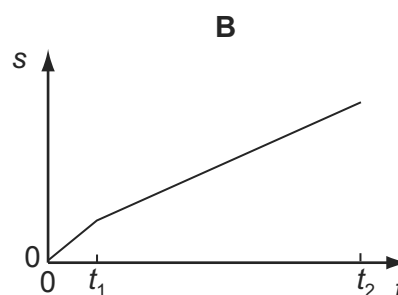
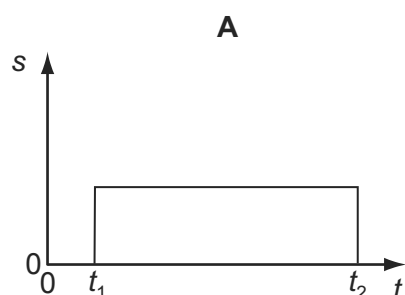

- 32 The diagram shows a velocity-time graph.

9702/12/O/N/09/Q6

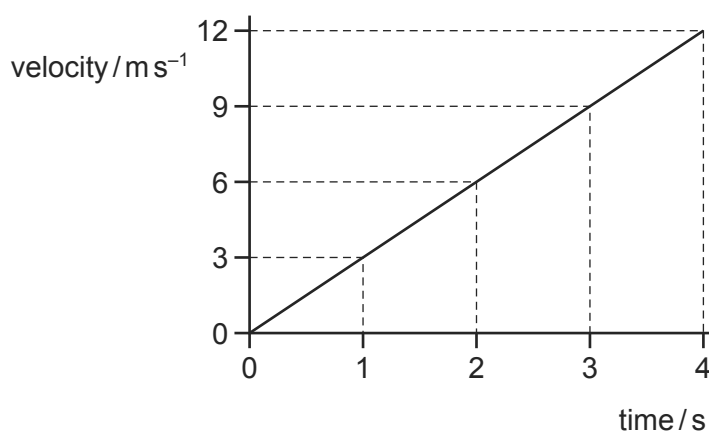

What is the displacement during the last 2 seconds of the motion?

- A** 6 m      **B** 12 m      **C** 18 m      **D** 24 m

- 33 A ball is released from rest above a horizontal surface and bounces several times. 9702/11/O/N/09/Q6

The graph shows how, for this ball, a quantity  $y$  varies with time.

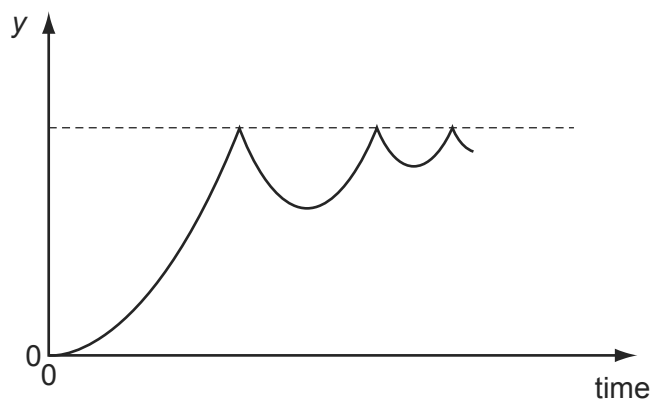

What is the quantity  $y$ ?

- A acceleration
  - B displacement
  - C kinetic energy
  - D velocity
- 34 The diagram shows a velocity-time graph. 9702/11/O/N/09/Q7

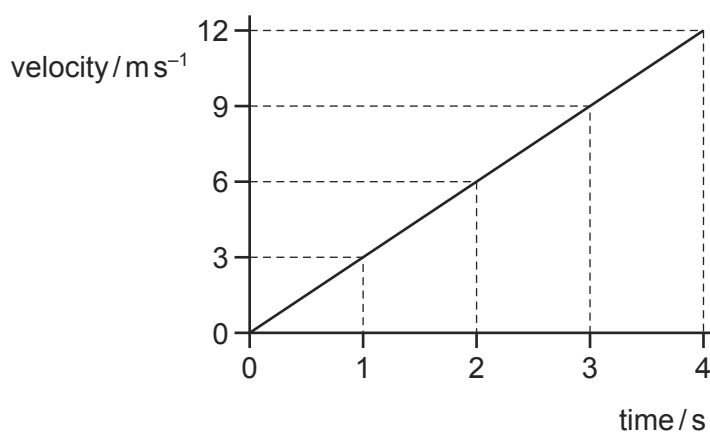

What is the displacement during the last 2 seconds of the motion?

- A 6 m
  - B 12 m
  - C 18 m
  - D 24 m
- 35 Which statement about a ball that strikes a tennis racket and rebounds is **always** correct? 9702/12/O/N/09/Q7

- A Total kinetic energy of the ball is conserved.
- B Total kinetic energy of the system is conserved.
- C Total momentum of the ball is conserved.
- D Total momentum of the system is conserved.



36 The diagram shows an oscilloscope screen displaying two signals.

9702/12/O/N/09/Q3

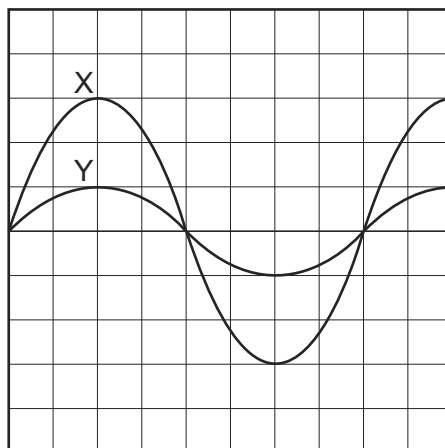

Signal X has a frequency of 50 Hz and peak voltage of 12 V.

What is the period and peak voltage of signal Y?

	period / ms	peak voltage / V
<b>A</b>	20	4
<b>B</b>	20	12
<b>C</b>	50	4
<b>D</b>	50	12

37 A ball is released from rest above a horizontal surface and bounces several times. 9702/12/O/N/09/Q5

The graph shows how, for this ball, a quantity  $y$  varies with time.

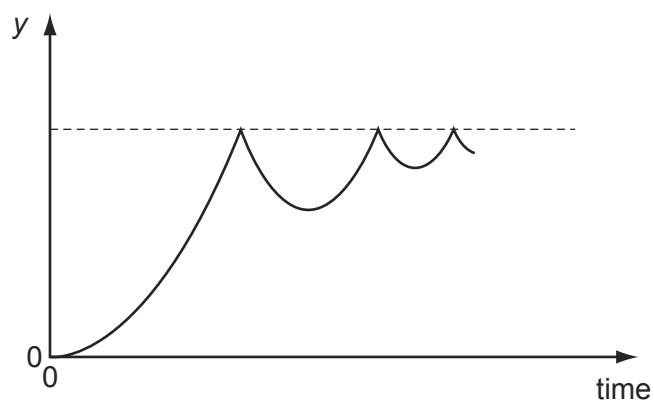

What is the quantity  $y$ ?

- A** acceleration
- B** displacement
- C** kinetic energy
- D** velocity

38 A small steel ball falls freely under gravity after being released from rest.

9702/12/M/J/10/Q8

Which graph best represents the variation of the height  $h$  of the ball with time  $t$ ?

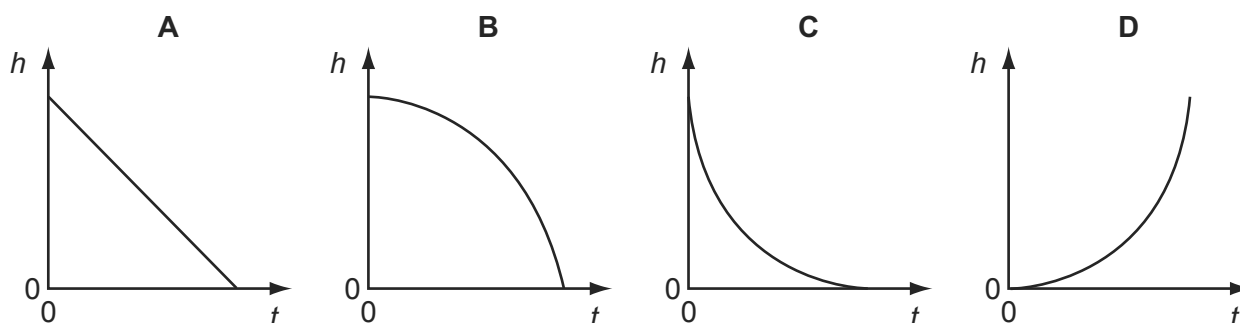

39 The diagram shows a velocity-time graph for a vehicle.

9702/12/M/J/10/Q9

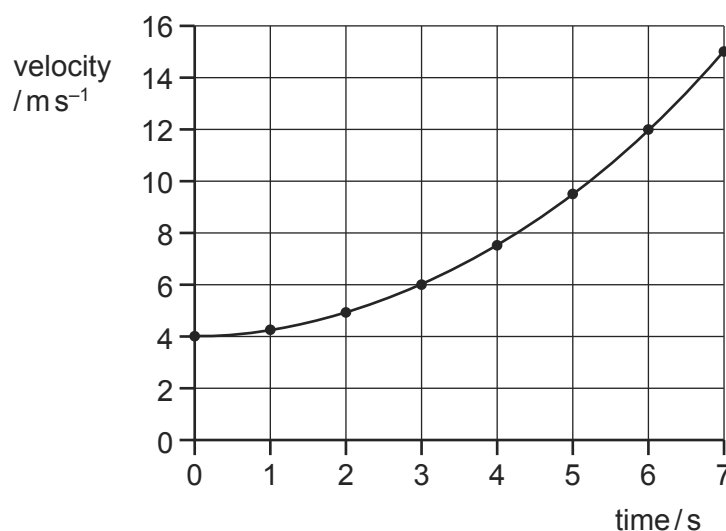

The vehicle, moving at  $4.0 \text{ ms}^{-1}$ , begins to accelerate at time = 0.

What is the vehicle's acceleration at time = 3.0 s?

- A**  $0.67 \text{ ms}^{-2}$     **B**  $1.0 \text{ ms}^{-2}$     **C**  $1.3 \text{ ms}^{-2}$     **D**  $2.0 \text{ ms}^{-2}$

40 A small steel ball falls freely under gravity after being released from rest.

9702/11/M/J/10/Q9

Which graph best represents the variation of the height  $h$  of the ball with time  $t$ ?

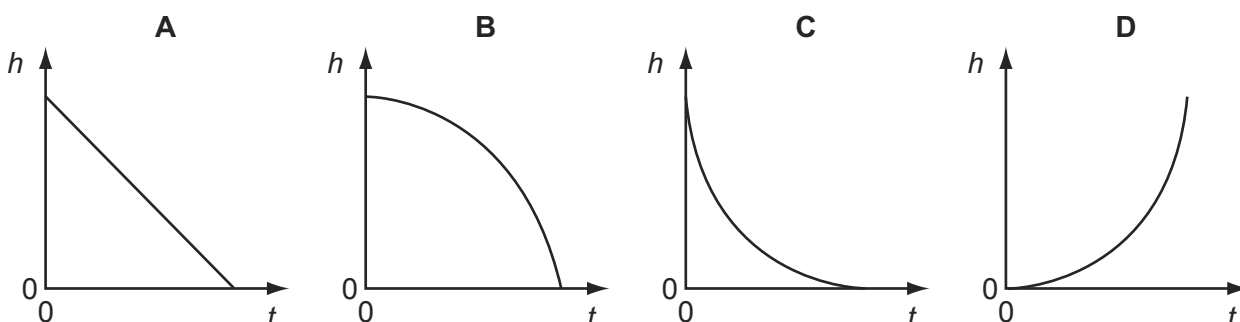

- 41 The diagram shows a velocity-time graph for a vehicle.

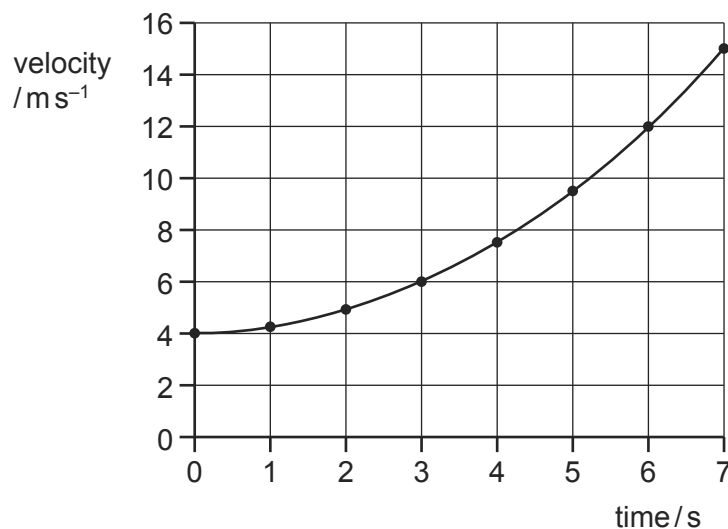

The vehicle, moving at  $4.0 \text{ ms}^{-1}$ , begins to accelerate at time = 0.

What is the vehicle's acceleration at time = 3.0 s?

- A**  $0.67 \text{ ms}^{-2}$     **B**  $1.0 \text{ ms}^{-2}$     **C**  $1.3 \text{ ms}^{-2}$     **D**  $2.0 \text{ ms}^{-2}$
- 42 The velocity-time graph below is for a stone thrown vertically up into the air. Air resistance is negligible.

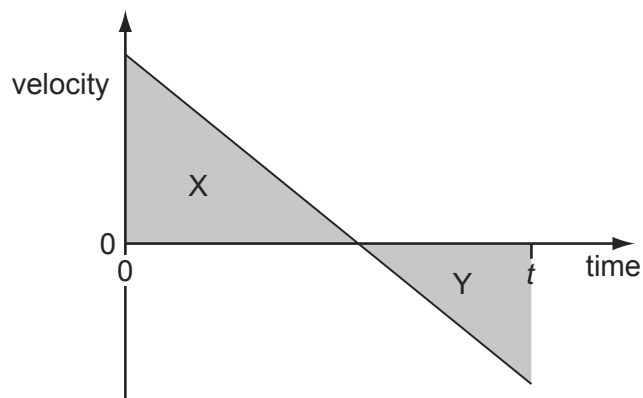

The stone is thrown up at time zero.

Area X represents a distance of 5 m. Area Y represents a distance of 3 m.

What is the displacement of the stone from its initial position at time  $t$ ?

- A** 2 m    **B** 3 m    **C** 5 m    **D** 8 m

- 43 A student throws a ball in the positive direction vertically upwards.

The ball makes an elastic collision with the ceiling, rebounds and accelerates back to the student's hand in a time of 1.2 s.

9702/12/O/N/10/Q7

Which graph best represents the acceleration of the ball from the moment it leaves the hand to the instant just before it returns to the hand?

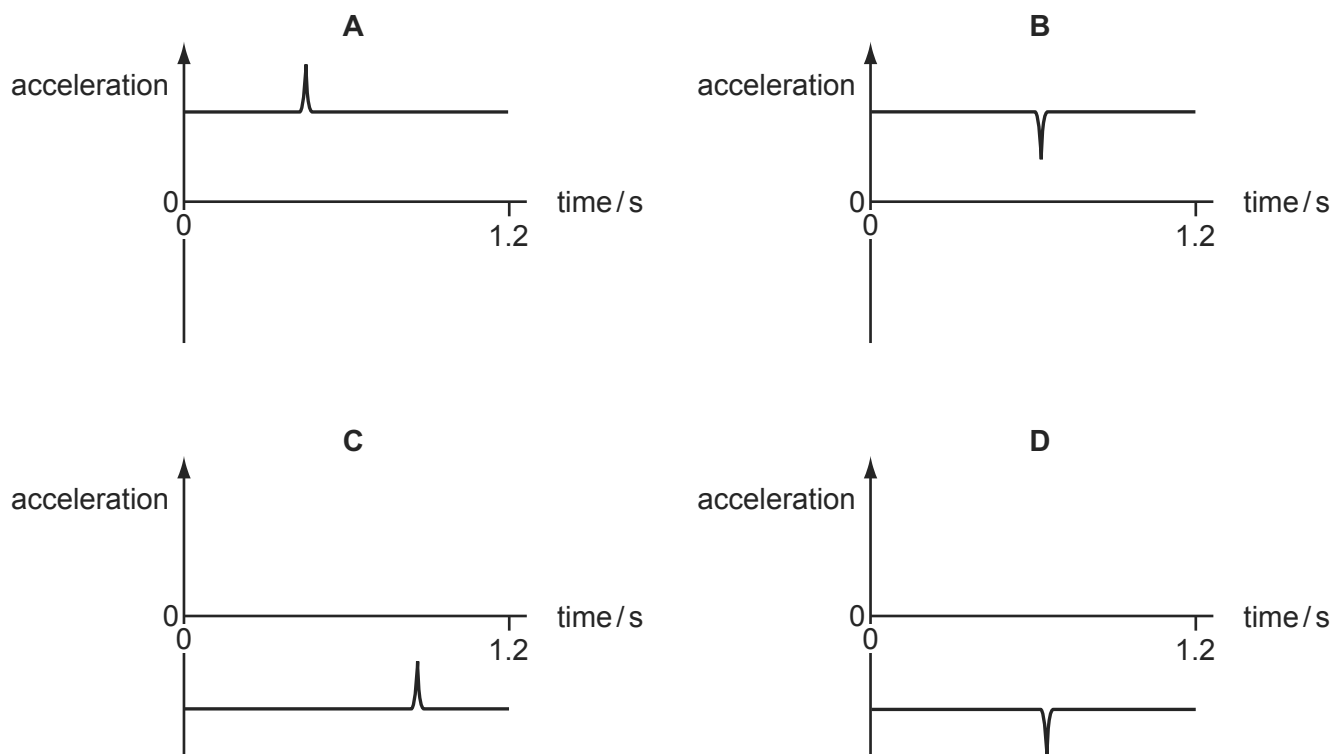

- 44 The velocity-time graph below is for a stone thrown vertically up into the air. Air resistance is negligible.

9702/13/O/N/10/Q6

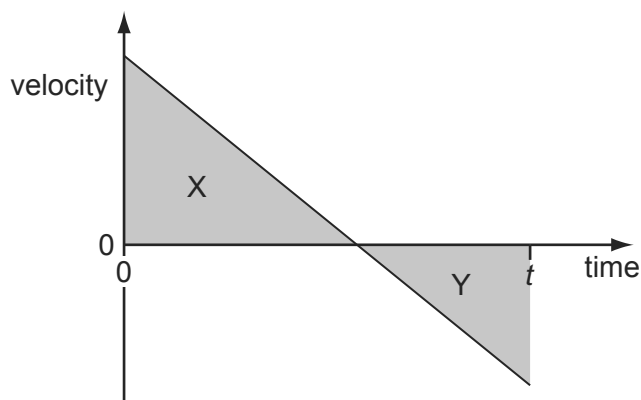

The stone is thrown up at time zero.

Area X represents a distance of 5 m. Area Y represents a distance of 3 m.

What is the displacement of the stone from its initial position at time  $t$ ?

- A** 2 m                      **B** 3 m                      **C** 5 m                      **D** 8 m

- 45 The graph shows how the acceleration of an object moving in a straight line varies with time.

9702/11/M/J/11/Q6

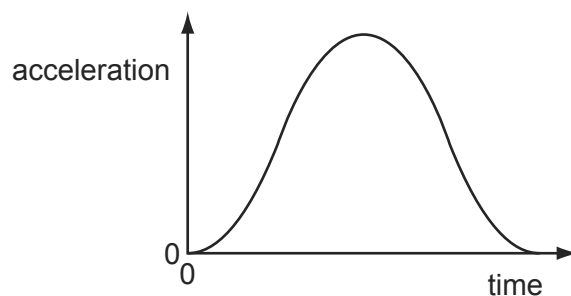

Which graph shows the variation with time of the velocity of the object?

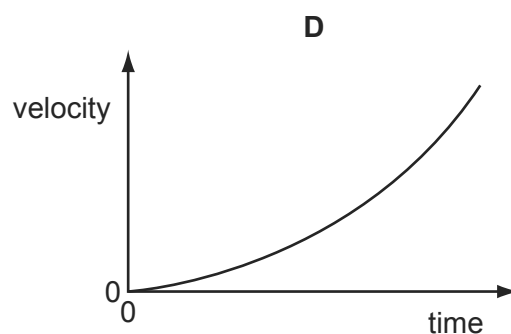
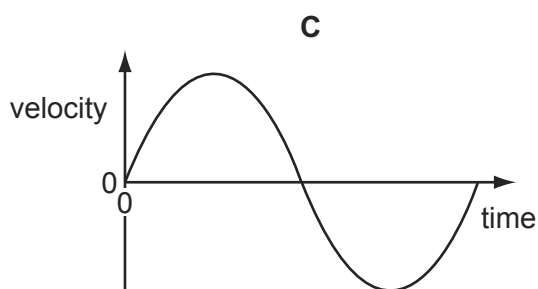
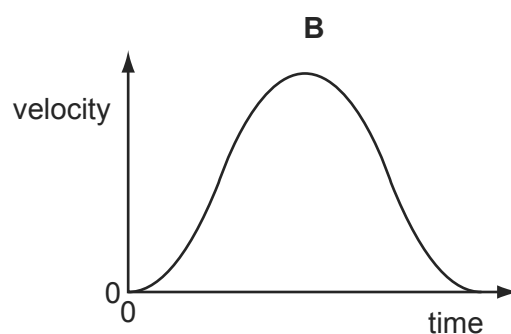
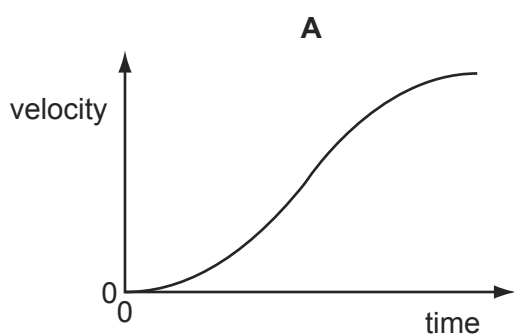

- 46 A boy throws a ball vertically upwards. It rises to a maximum height, where it is momentarily at rest, and then falls back to his hands.

9702/11/O/N/11/Q8

Which row gives the acceleration of the ball at various stages in its motion? (Take vertically upwards as positive. Ignore air resistance.)

	rising	at maximum height	falling
<b>A</b>	$-9.81 \text{ m s}^{-2}$	0	$+9.81 \text{ m s}^{-2}$
<b>B</b>	$-9.81 \text{ m s}^{-2}$	$-9.81 \text{ m s}^{-2}$	$-9.81 \text{ m s}^{-2}$
<b>C</b>	$+9.81 \text{ m s}^{-2}$	$+9.81 \text{ m s}^{-2}$	$+9.81 \text{ m s}^{-2}$
<b>D</b>	$+9.81 \text{ m s}^{-2}$	0	$-9.81 \text{ m s}^{-2}$

- 47 A ball is released from rest at time zero. After 1.0 s it bounces inelastically from a horizontal surface and rebounds, reaching the top of its first bounce after 1.5 s.

9702/11/M/J/11/Q7

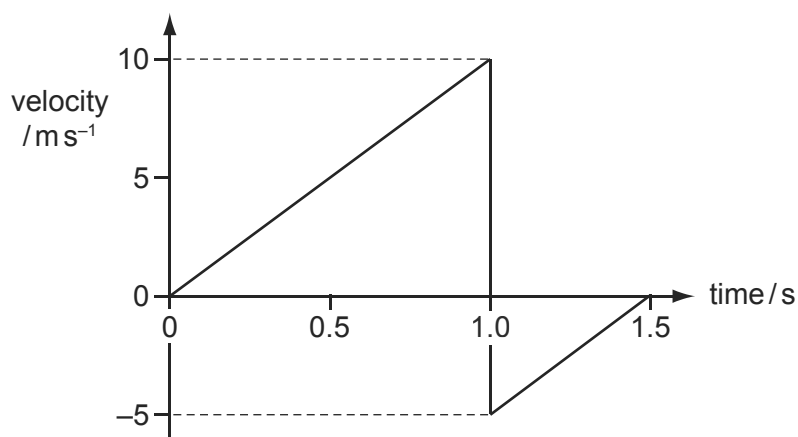

What is the total displacement of the ball from its original position after 1.5 s?

- A** 1.25 m      **B** 3.75 m      **C** 5.00 m      **D** 6.25 m
- 48 The graph shows how the acceleration of an object moving in a straight line varies with time.

9702/13/M/J/11/Q7

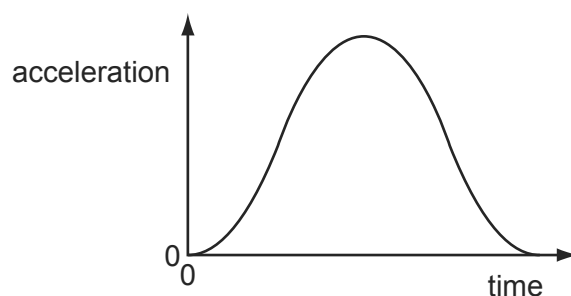

Which graph shows the variation with time of the velocity of the object?

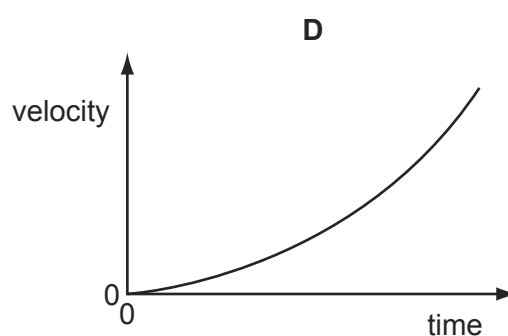
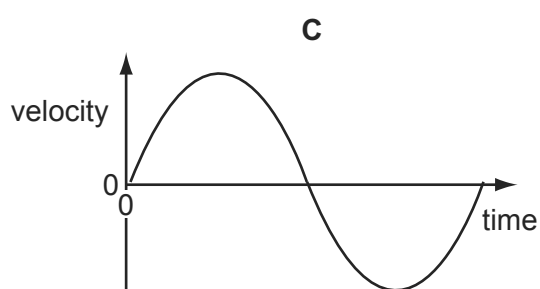
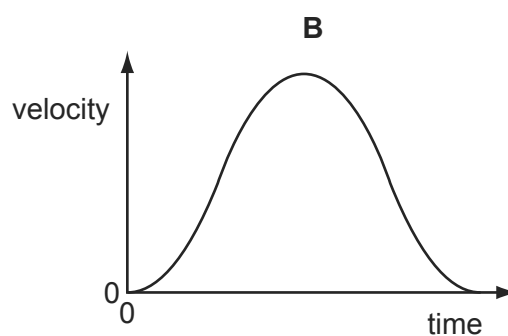
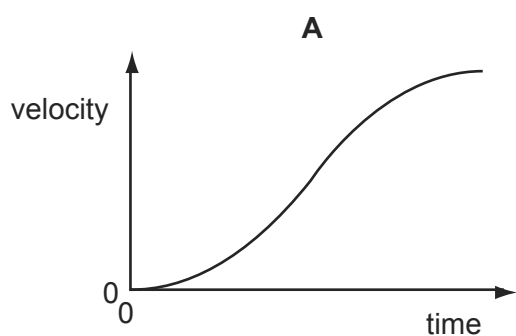

- 49 A particle moves in the manner shown by the velocity-time graph.

9702/12/M/J/11/Q7

The displacement of the particle has been measured so that it is zero at  $t = 0$ . Point Q refers to a point in its motion.

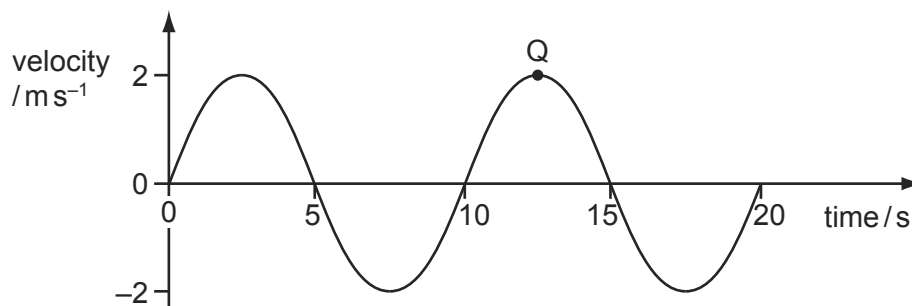

Which row of the table is correct?

	times for maximum displacement/s		acceleration at point Q/ $\text{m s}^{-2}$
<b>A</b>	2.5	12.5	2
<b>B</b>	5	15	2
<b>C</b>	2.5	12.5	0
<b>D</b>	5	15	0

- 50 A tennis ball falls freely, in air, from the top of a tall building.

9702/12/M/J/11/Q8

Which graph best represents the variation of distance  $s$  fallen with time  $t$ ?

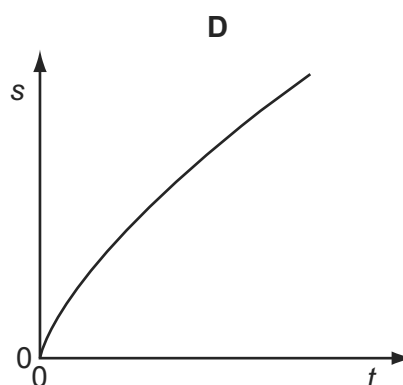
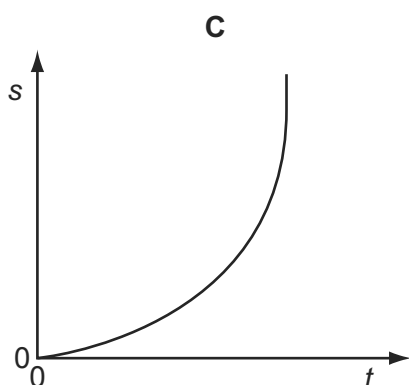
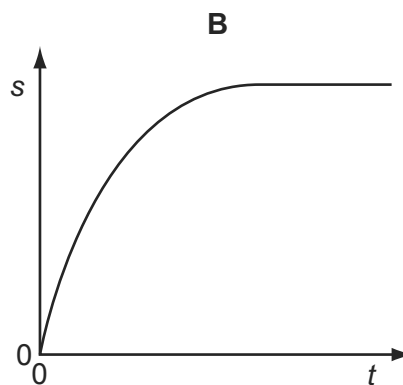
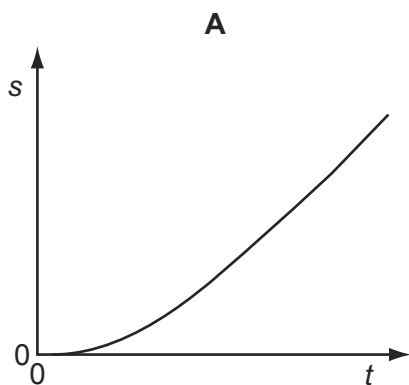

51 A small glider moves along a friction-free horizontal air track as shown below.

9702/12/M/J/11/Q9

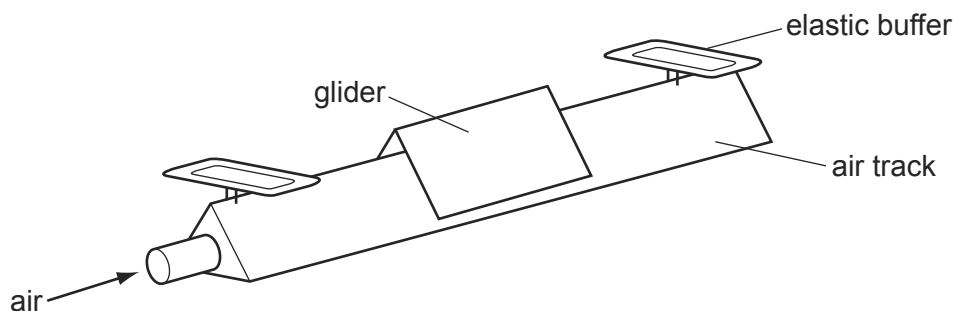

At each end of the air track there is a perfectly elastic buffer.

Which graph represents the variation with time  $t$  of the velocity  $v$  of the glider as it moves between the two buffers?

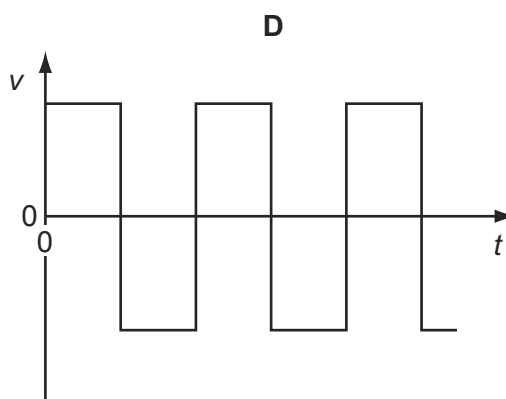
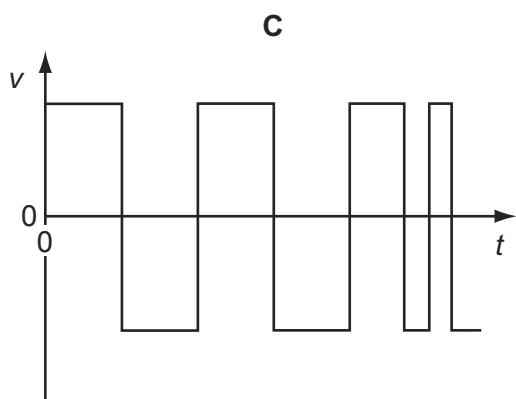
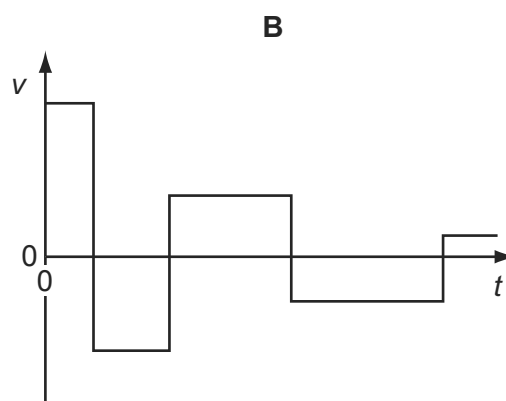
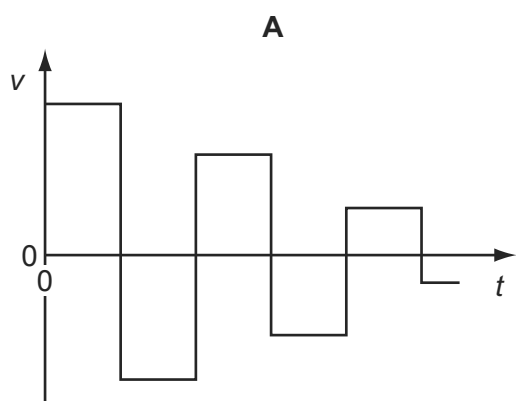

52 A brick is dislodged from a building and falls vertically under gravity.

9702/12/M/J/12/Q9

Which graph best represents the variation of its height  $h$  above the ground with time  $t$  if air resistance is negligible?

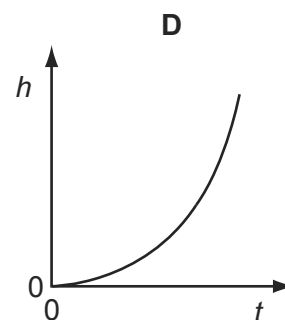
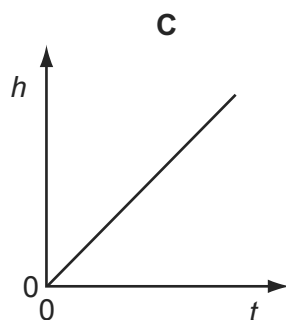
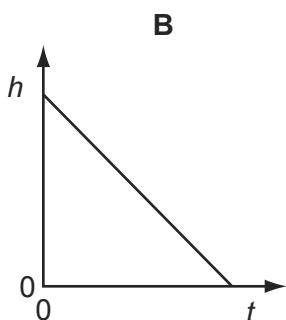
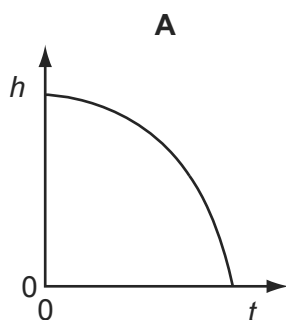



- 53 A ball is released from rest at time zero. After 1.0 s it bounces inelastically from a horizontal surface and rebounds, reaching the top of its first bounce after 1.5 s.

9702/13/M/J/11/Q8

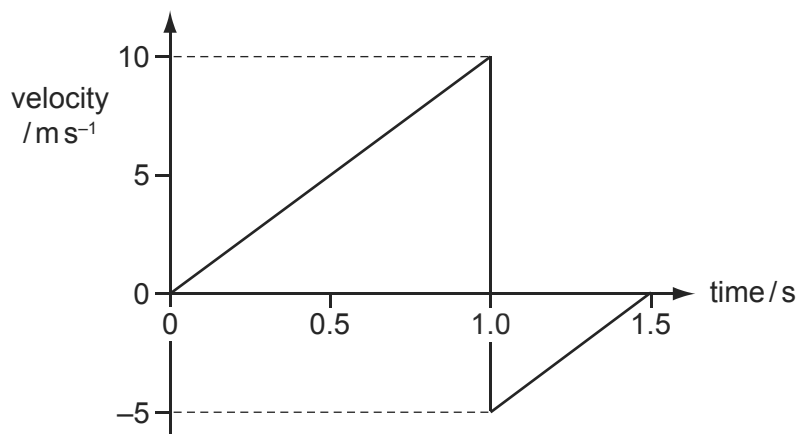

What is the total displacement of the ball from its original position after 1.5 s?

- A** 1.25 m      **B** 3.75 m      **C** 5.00 m      **D** 6.25 m
- 54 A tennis ball is released from rest at the top of a tall building.

9702/11/O/N/11/Q7

Which graph best represents the variation with time  $t$  of the acceleration  $a$  of the ball as it falls, assuming that the effect of air resistance is **not** negligible?

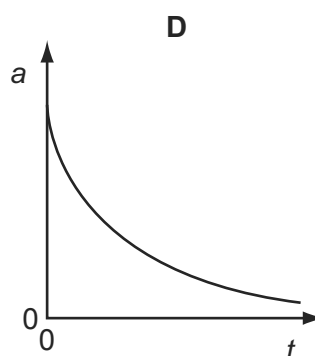
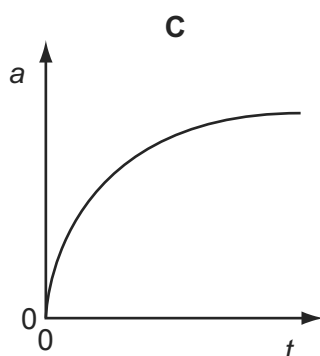
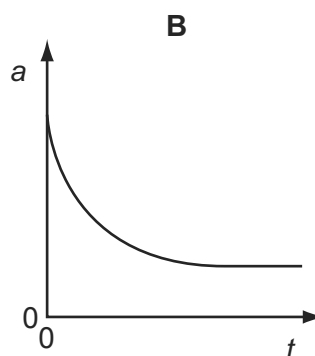
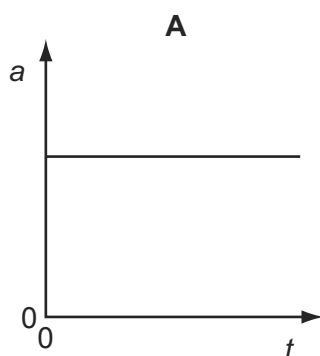

55 A ball is released from rest on a smooth slope XY.

9702/11/O/N/11/Q6

It moves down the slope, along a smooth horizontal surface YZ and rebounds inelastically at Z. Then it moves back to Y and comes to rest momentarily somewhere on XY.

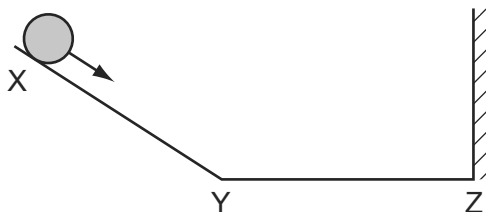

Which velocity-time graph represents the motion of the ball?

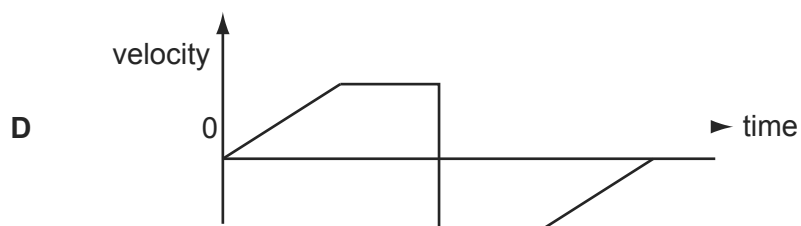
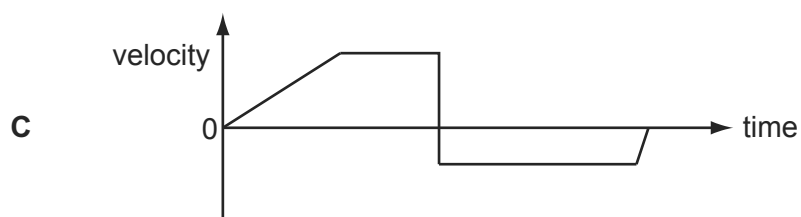
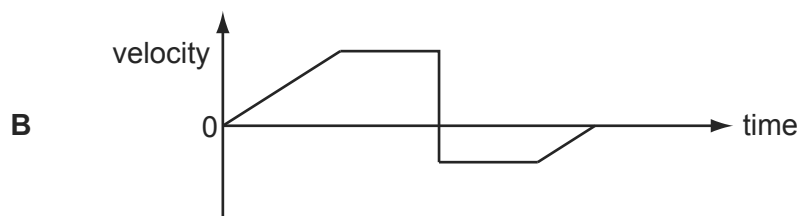
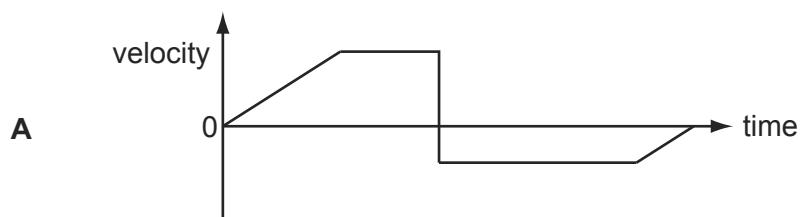

56 Which feature of a graph allows acceleration to be determined?

9702/13/M/J/12/Q6

- A** the area under a displacement-time graph
- B** the area under a velocity-time graph
- C** the slope of a displacement-time graph
- D** the slope of a velocity-time graph

57 The variation with time  $t$  of the distance  $s$  moved by a body is shown below.

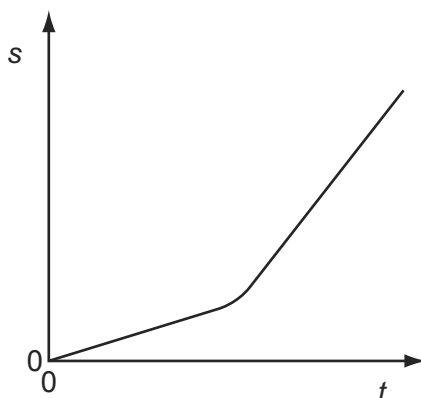

What can be deduced from the graph about the motion of the body?

- A** It accelerates continuously.
- B** It starts from rest.
- C** The distance is proportional to time.
- D** The speed changes.

58 The velocity of an object during the first five seconds of its motion is shown on the graph.

9702/12/O/N/11/Q6

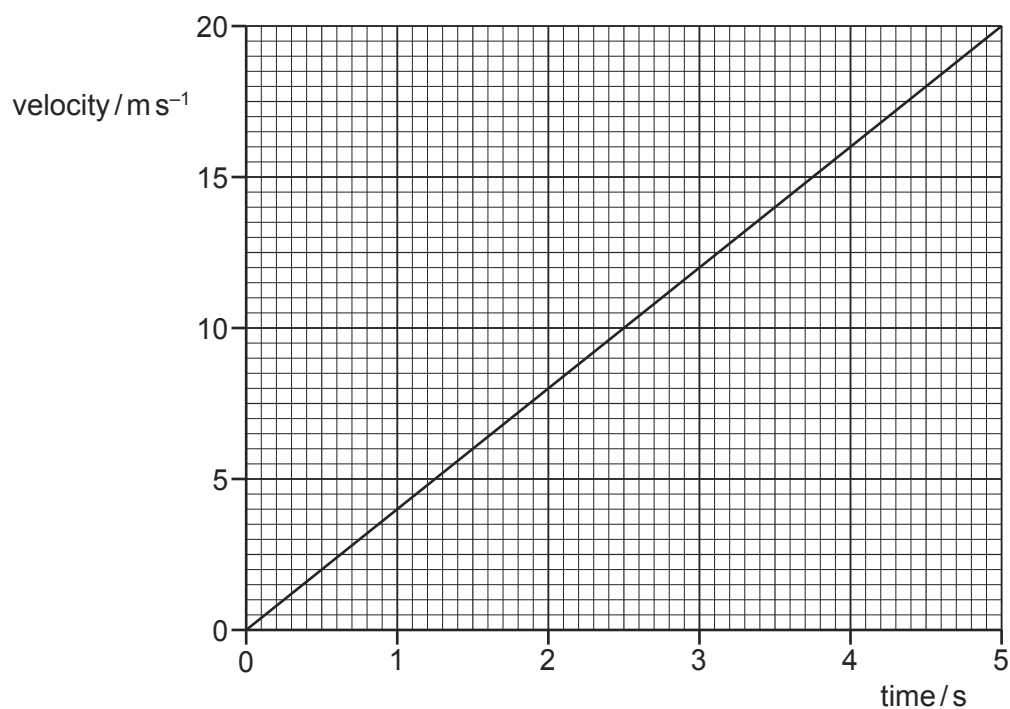

What is the distance travelled by the object in this time?

- A** 4 m
- B** 20 m
- C** 50 m
- D** 100 m

59 A tennis ball is released from rest at the top of a tall building.

9702/13/O/N/11/Q6

Which graph best represents the variation with time  $t$  of the acceleration  $a$  of the ball as it falls, assuming that the effect of air resistance is **not** negligible?

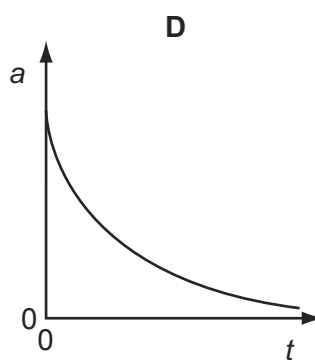
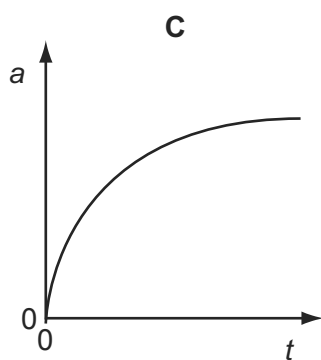
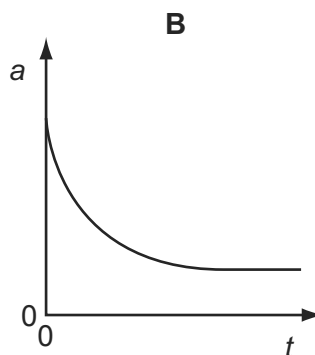
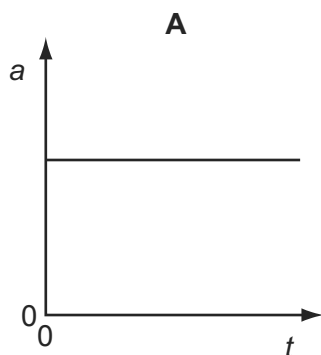

60 A golf ball is hit with the same force and direction on the Earth and on the Moon.

9702/12/O/N/12/Q10

Which diagram best represents the shapes of the paths taken by the golf ball?

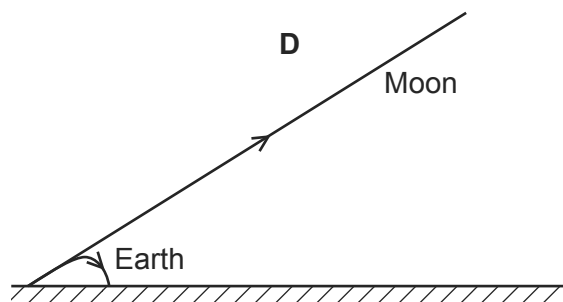
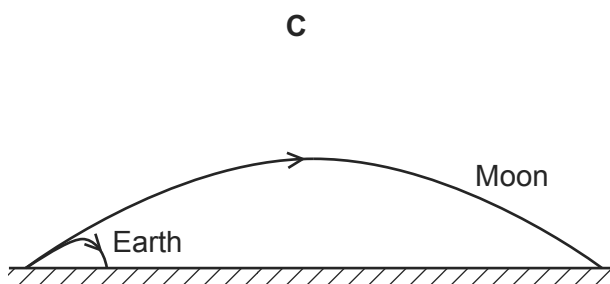
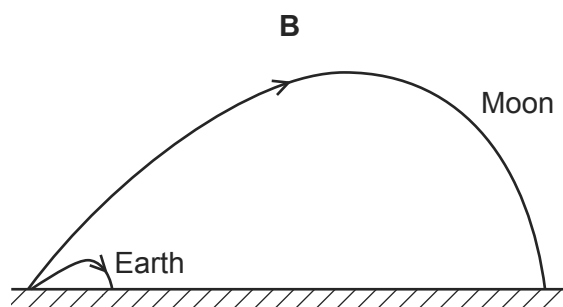
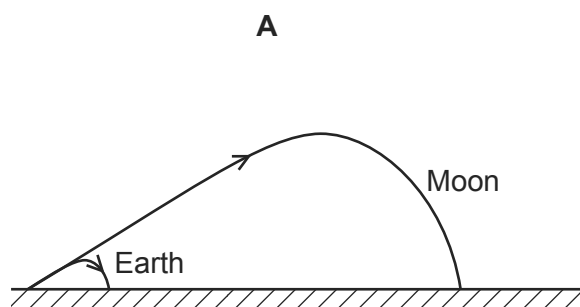

61 A ball is released from rest on a smooth slope XY.

9702/13/O/N/11/Q7

It moves down the slope, along a smooth horizontal surface YZ and rebounds inelastically at Z. Then it moves back to Y and comes to rest momentarily somewhere on XY.

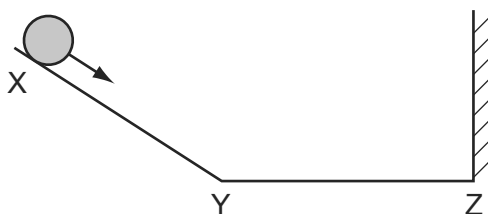

Which velocity-time graph represents the motion of the ball?

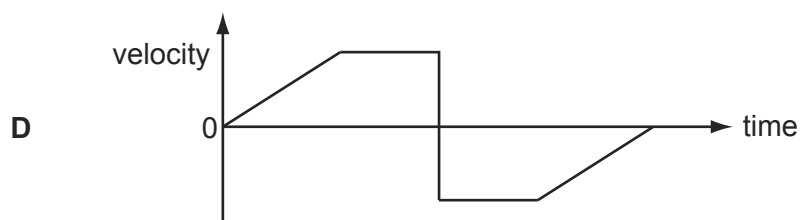
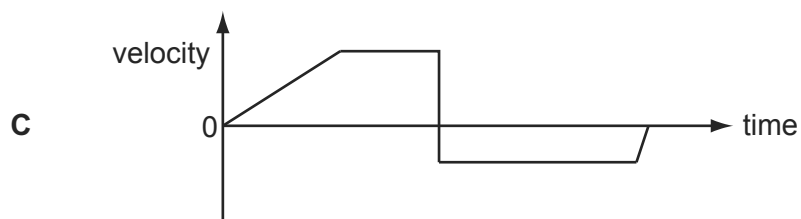
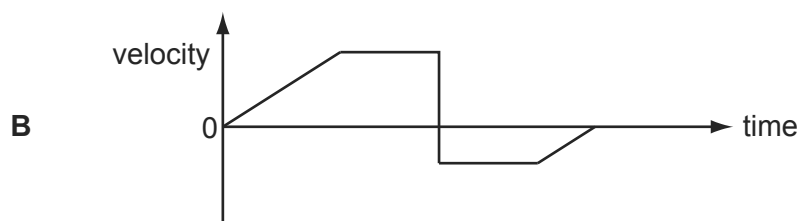
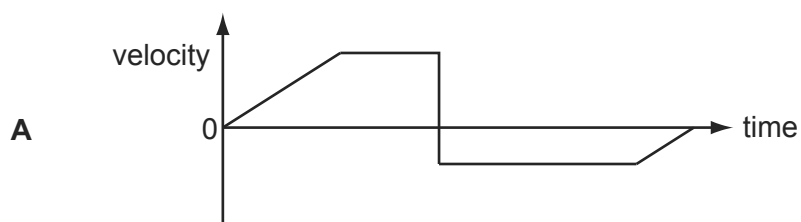

- 62 A boy throws a ball vertically upwards. It rises to a maximum height, where it is momentarily at rest, and then falls back to his hands. 9702/13/O/N/11/Q9

Which row gives the acceleration of the ball at various stages in its motion? (Take vertically upwards as positive. Ignore air resistance.)

	rising	at maximum height	falling
<b>A</b>	$-9.81 \text{ ms}^{-2}$	0	$+9.81 \text{ ms}^{-2}$
<b>B</b>	$-9.81 \text{ ms}^{-2}$	$-9.81 \text{ ms}^{-2}$	$-9.81 \text{ ms}^{-2}$
<b>C</b>	$+9.81 \text{ ms}^{-2}$	$+9.81 \text{ ms}^{-2}$	$+9.81 \text{ ms}^{-2}$
<b>D</b>	$+9.81 \text{ ms}^{-2}$	0	$-9.81 \text{ ms}^{-2}$

- 63 The graph shows how the velocity  $v$  of an object moving in a straight line varies over time  $t = 0$  to  $t = T$ . 9702/12/M/JJ/12/Q7

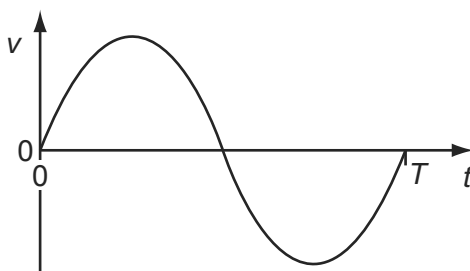

Which graph represents the displacement  $s$  of the object in the time  $t = 0$  to  $t = T$ ?

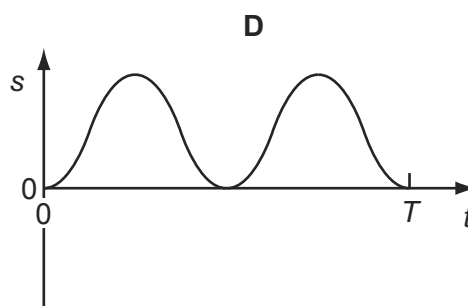
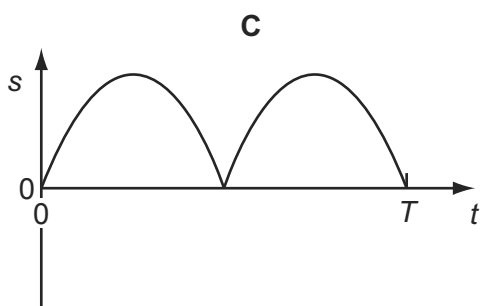
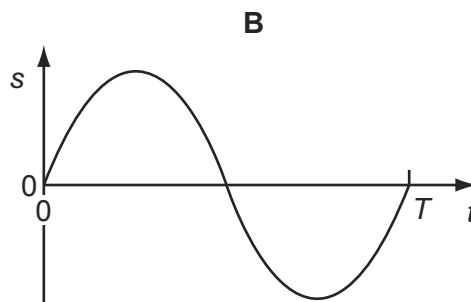
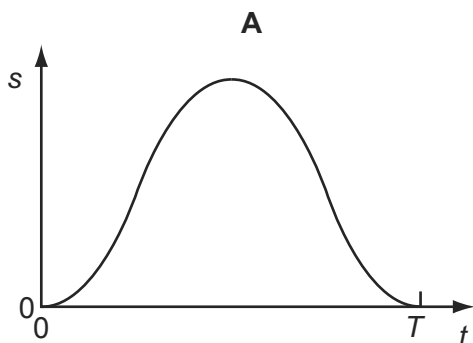

64 The graph of velocity against time for an object moving in a straight line is shown. 9702/12/O/N/12/Q9

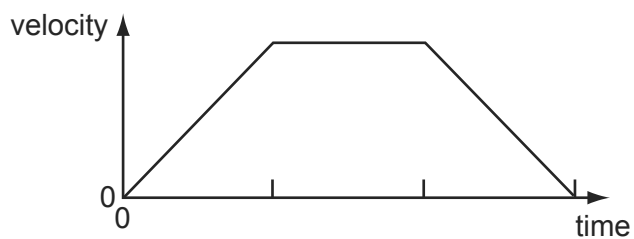

What is the corresponding graph of displacement against time?

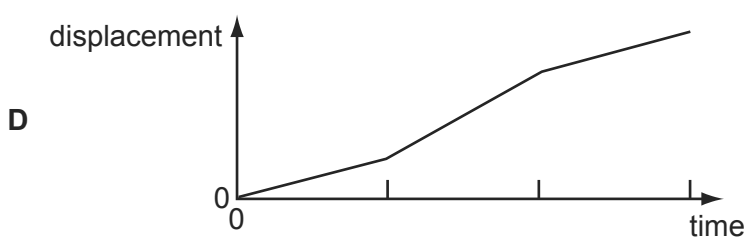
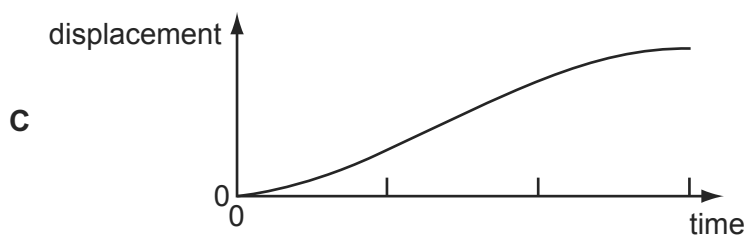
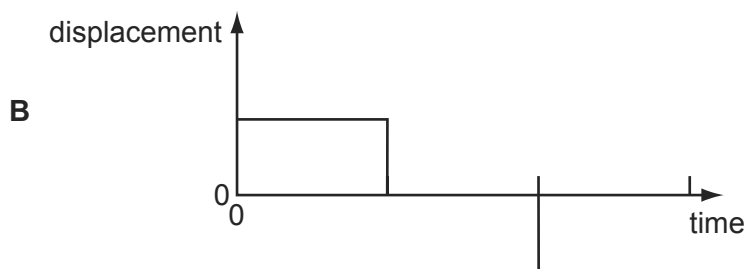
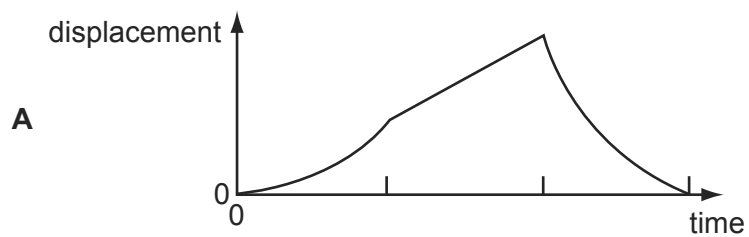

65 The dotted line shows the path of a competitor in a ski-jumping competition.

9702/12/O/N/12/Q10

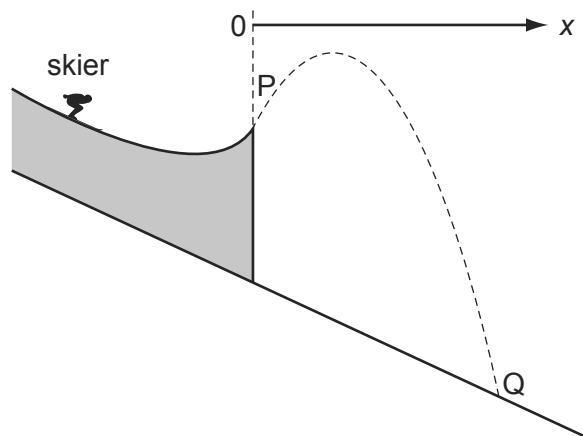

Ignoring air resistance, which graph best represents the variation of his speed  $v$  with the horizontal distance  $x$  covered from the start of his jump at P before landing at Q?

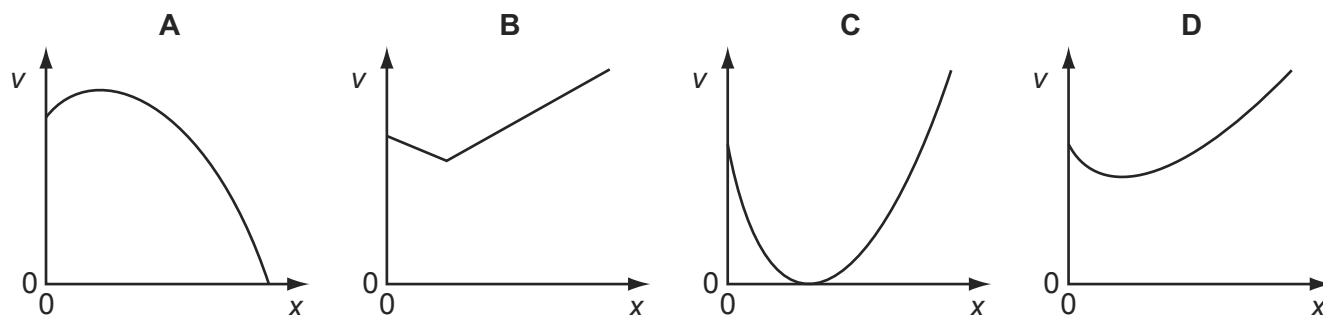

66 The velocity of a car changes as shown.

9702/12/O/N/12/Q11

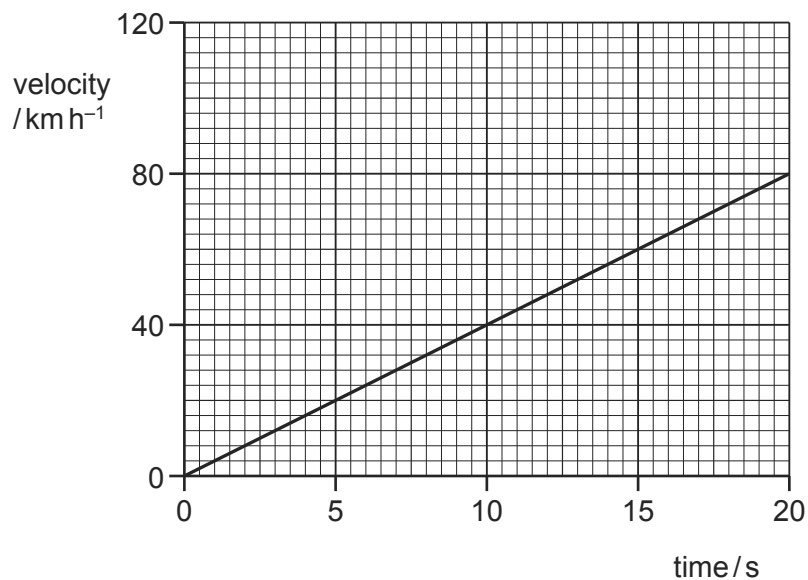

What is the acceleration of the car?

- A**  $1.1 \text{ ms}^{-2}$       **B**  $4.0 \text{ ms}^{-2}$       **C**  $224 \text{ ms}^{-2}$       **D**  $800 \text{ ms}^{-2}$



67 The velocity of an electric car changes as shown.

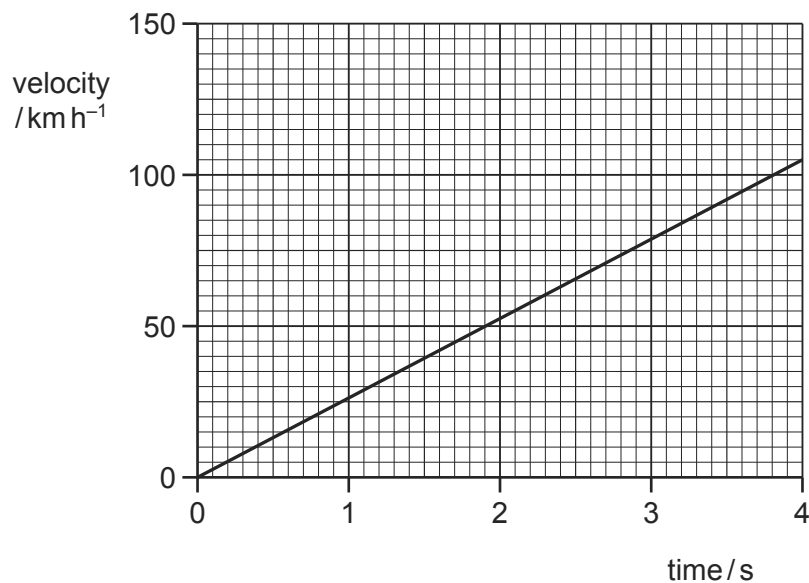

What is the acceleration of the car?

- A**  $190 \text{ ms}^{-2}$       **B**  $53 \text{ ms}^{-2}$       **C**  $26 \text{ ms}^{-2}$       **D**  $7.3 \text{ ms}^{-2}$

68 A ball is released from rest above a horizontal surface. It bounces once and is caught. 9702/1/O/N/12

9702/13/O/N/12/Q9

Which graph represents the variation with time  $t$  of the velocity  $v$  of the ball?

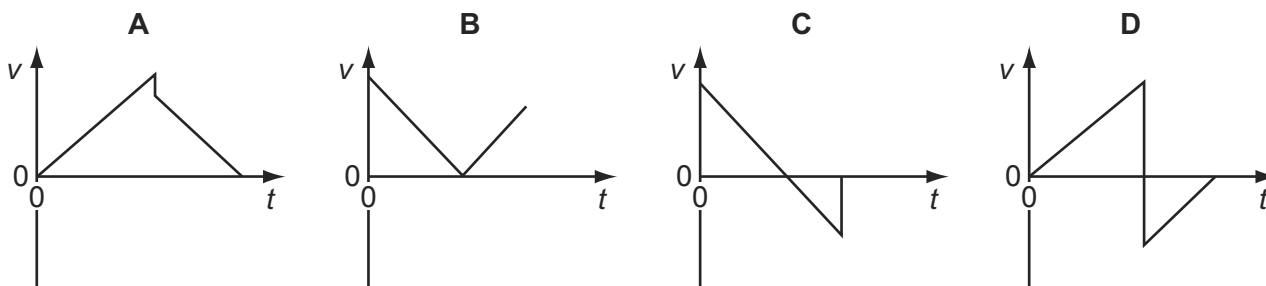

- 69 A mass on the end of a spring bounces up and down as shown, after being released at time  $t = 0$ .

9702/13/O/N/12/Q10

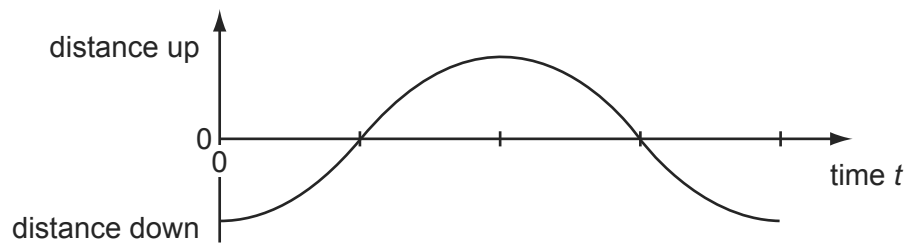

Which graph shows how the velocity varies with time?

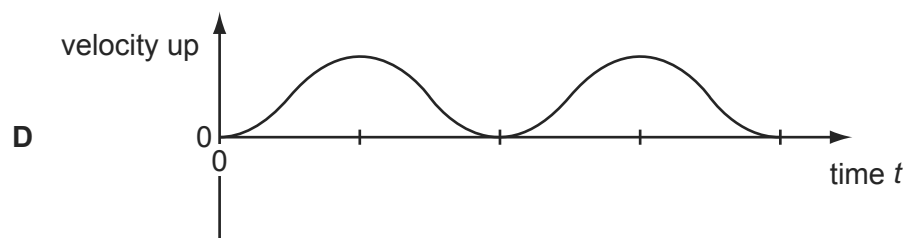
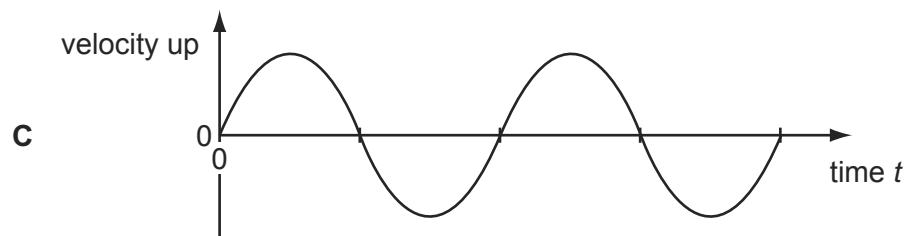
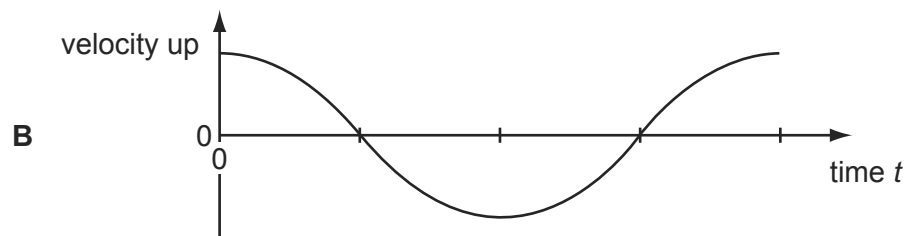
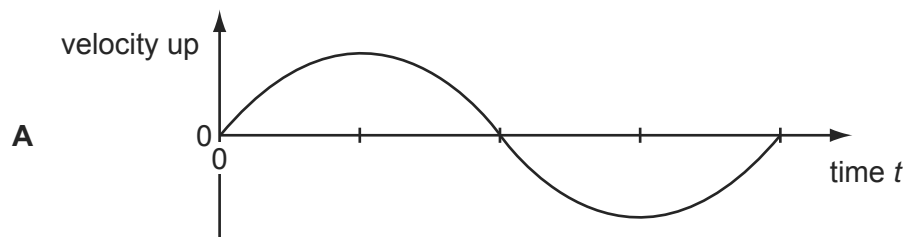

- 70 A car is stationary at traffic lights. When the traffic lights go green, the driver presses down sharply on the accelerator. The resultant horizontal force acting on the car varies with time as shown.

9702/11/M/J/13/Q9

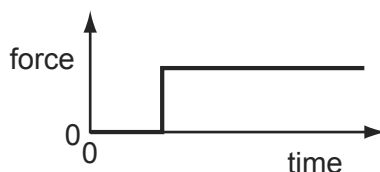

Which graph shows the variation with time of the speed of the car?

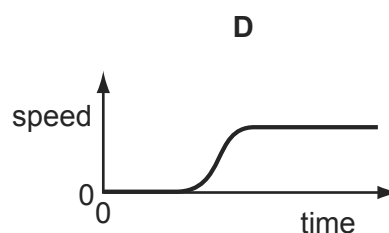
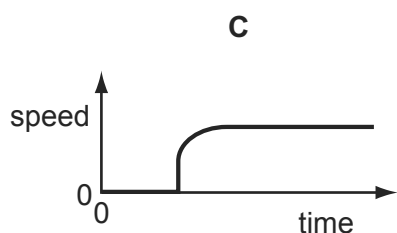
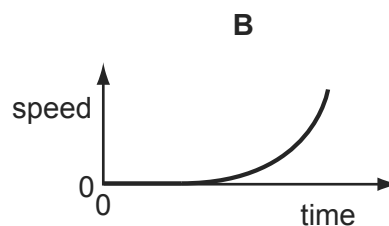
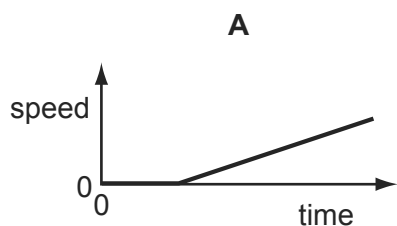

- 71 A sky diver falls vertically from a stationary balloon. She leaves the balloon at time  $t = 0$ . At time  $t = T$ , she reaches terminal velocity. Beyond the time shown in the graphs, she opens her parachute.

9702/12/M/J/13/Q6

Which graph shows the variation with time  $t$  of the force  $F$  due to air resistance?

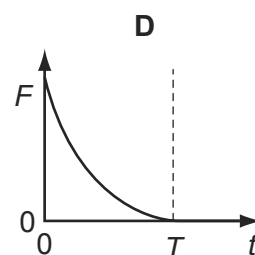
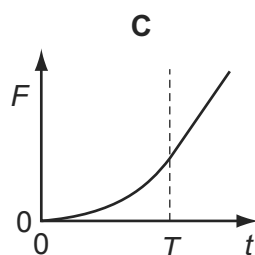
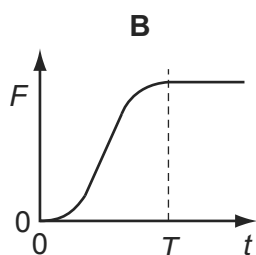
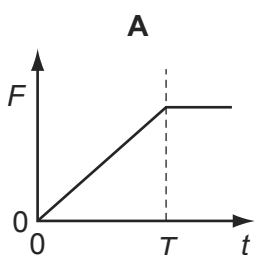

- 72 A ball is released from rest above a horizontal surface and bounces several times. 9702/12/M/J/13/Q8

The graph shows how, for this ball, a quantity  $y$  varies with time.

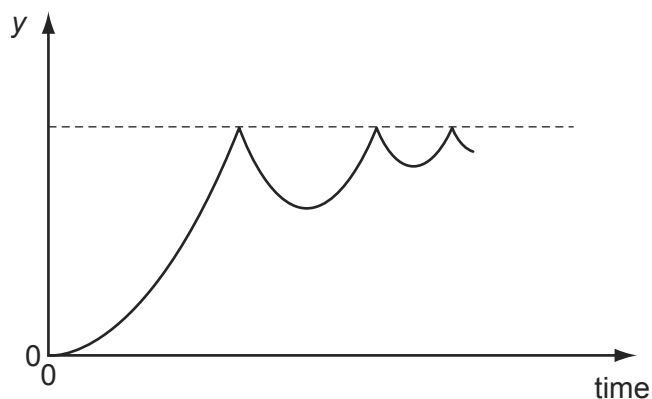

What is the quantity  $y$ ?

- A acceleration
  - B displacement
  - C kinetic energy
  - D velocity
- 73 At time  $t = 0$ , a body moves from rest with constant acceleration in a straight line. At time  $t$ , the body is distance  $s$  from its rest position. 9702/13/M/J/13/Q8

A graph is drawn of  $s$  against  $t^2$ , as shown.

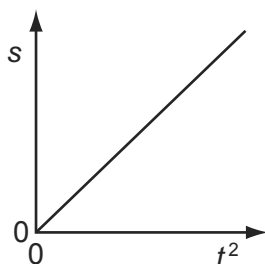

Which statement describes the acceleration of the body?

- A It is equal to half the value of the gradient of the graph.
- B It is equal to the value of the gradient of the graph.
- C It is equal to twice the value of the gradient of the graph.
- D It is equal to the reciprocal of the gradient of the graph.

74 The graph shows how velocity  $v$  varies with time  $t$  for a bungee jumper.

9702/11/O/N/13/Q7

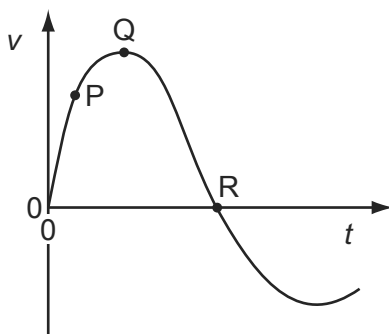

At which point is the bungee jumper momentarily at rest and at which point does she have zero acceleration?

	jumper at rest	jumper with zero acceleration
<b>A</b>	Q	P
<b>B</b>	Q	R
<b>C</b>	R	Q
<b>D</b>	R	R

75 The graph shows how the velocity  $v$  of a firework rocket changes with time  $t$ .

9702/13/O/N/13/Q7

At which point on the graph does the rocket have the greatest acceleration?

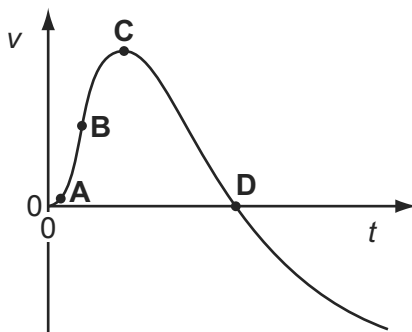

- 76 The graph shows how the acceleration of an object moving in a straight line varies with time.

9702/11/M/J/14/Q8

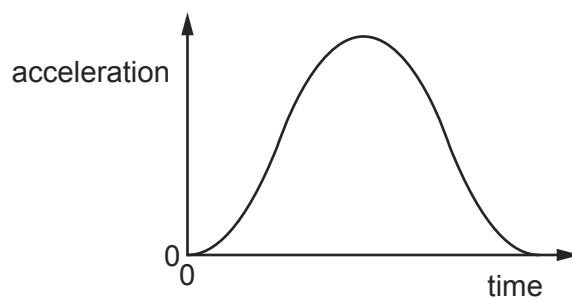

The object starts from rest.

Which graph shows the variation with time of the velocity of the object over the same time interval?

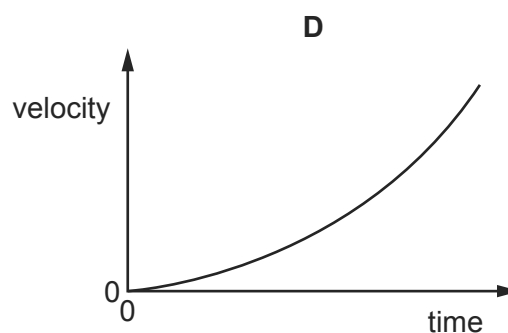
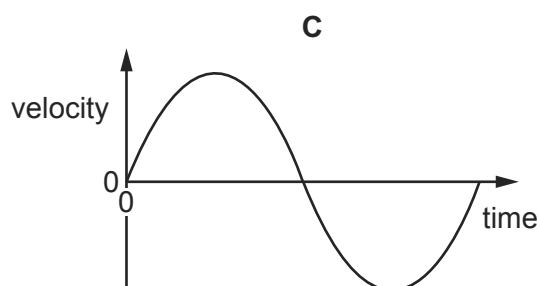
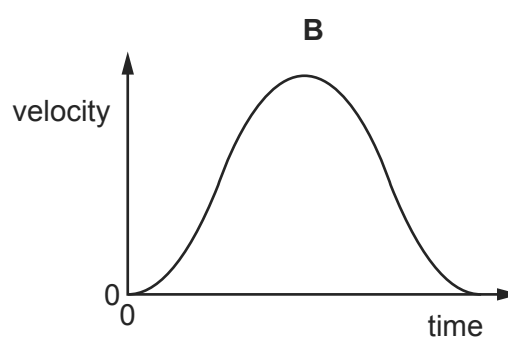
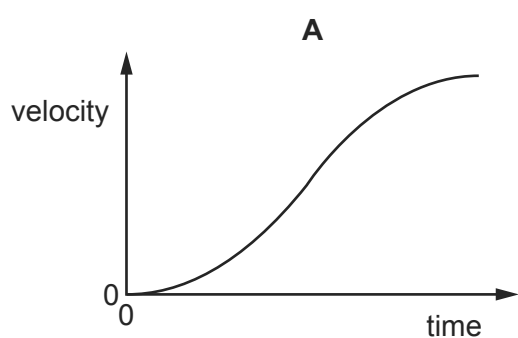

- 77 The diagram shows a velocity-time graph for a mass moving up and down on the end of a spring.

Which point represents the velocity of the mass when at the lowest point of its motion?

9702/13/O/N/14/Q7

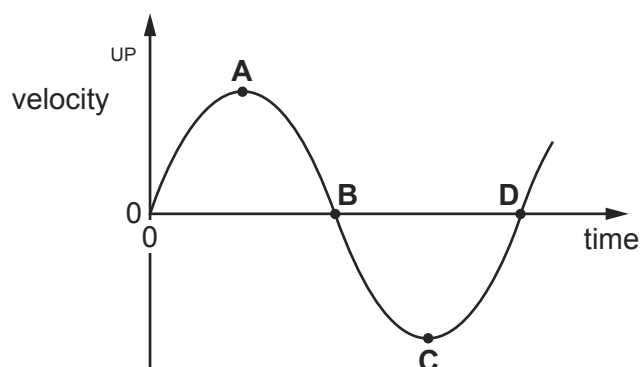

78 The graph shows how the speed  $v$  of a sprinter changes with time  $t$  during a 100 m race.

9702/13/M/J/14/Q9

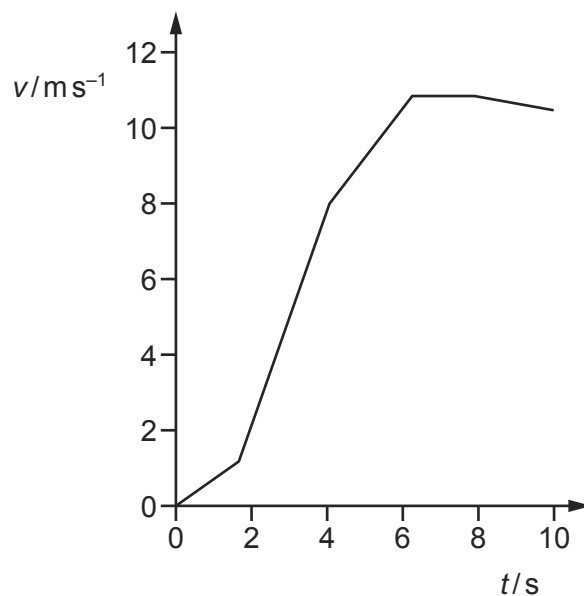

What is the best estimate of the maximum acceleration of the sprinter?

- A**  $0.5 \text{ ms}^{-2}$       **B**  $1 \text{ ms}^{-2}$       **C**  $3 \text{ ms}^{-2}$       **D**  $10 \text{ ms}^{-2}$

79 Which graph represents the motion of a car that is travelling along a straight road with a speed that increases uniformly with time?

9702/11/O/N/14/Q6

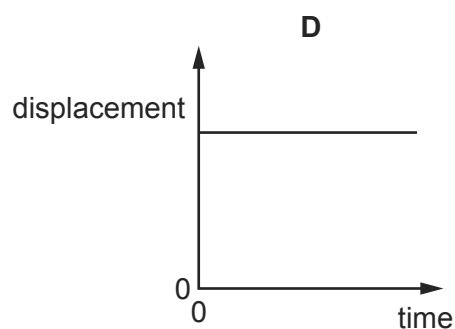
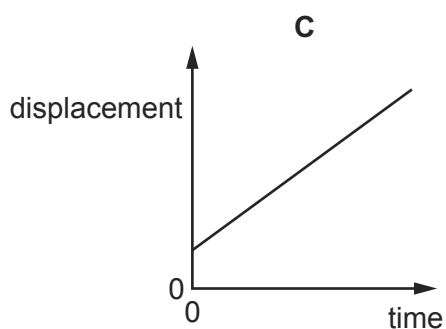
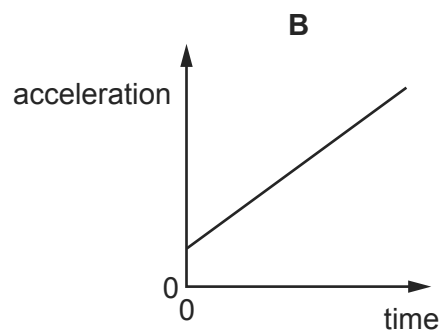
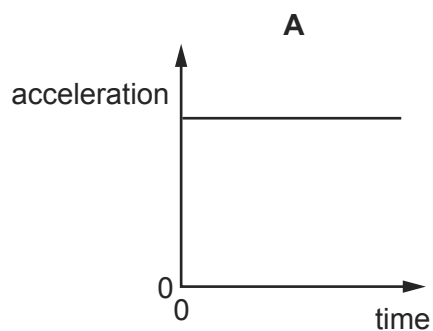

80 A ball is released from rest on a smooth slope XY.

It moves down the slope, along a smooth horizontal surface YZ and rebounds inelastically at Z. Then it moves back to Y and comes to rest momentarily somewhere on XY.

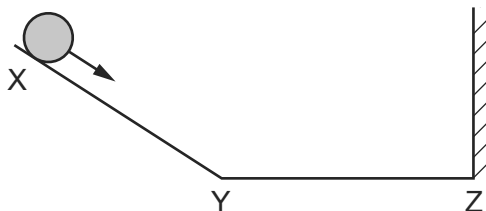

Which velocity-time graph represents the motion of the ball?

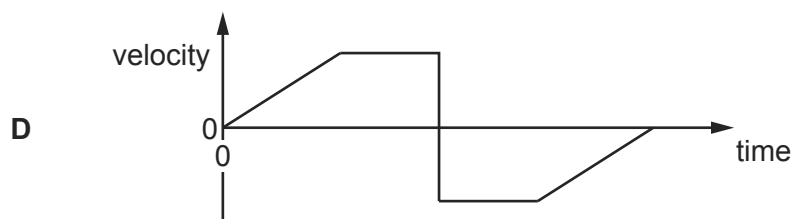
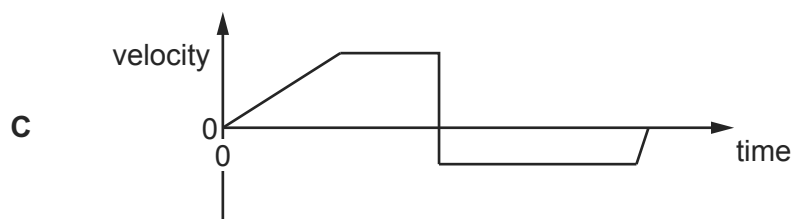
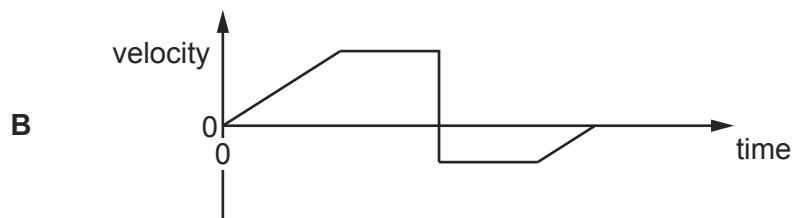
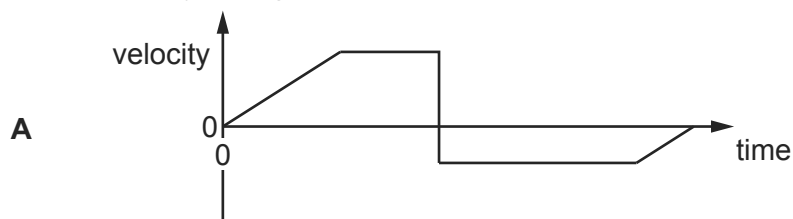



81 A wave pulse moves along a stretched rope in the direction shown.

9702/13/M/J/15/Q26

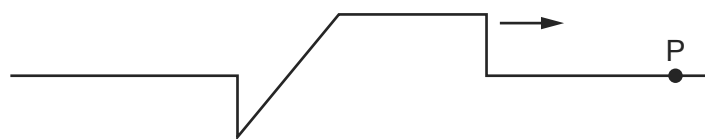

Which diagram correctly shows the variation with time  $t$  of the displacement  $s$  of the particle P in the rope?

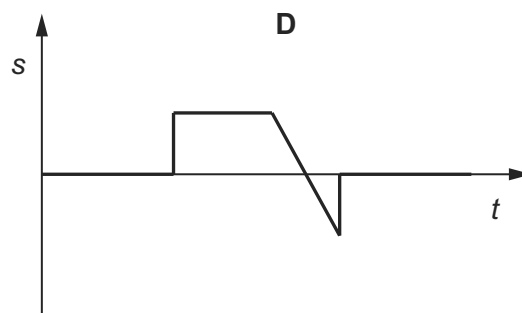
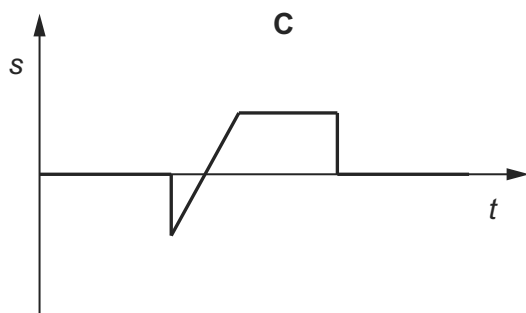
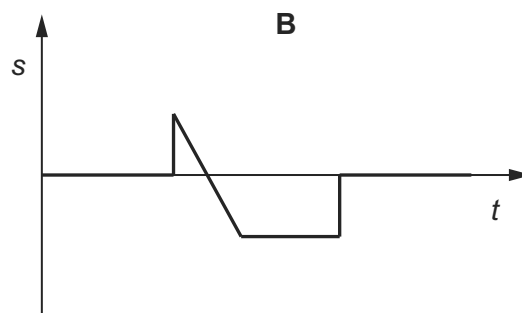
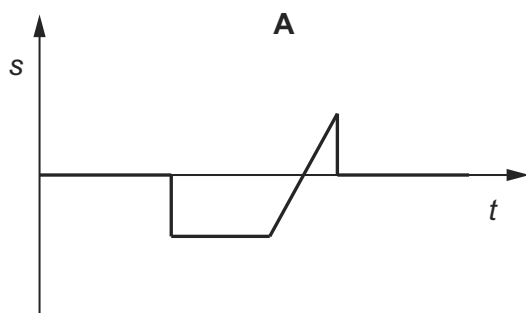

82 The velocity of an electric car changes as shown.

9702/13/M/J/15/Q8

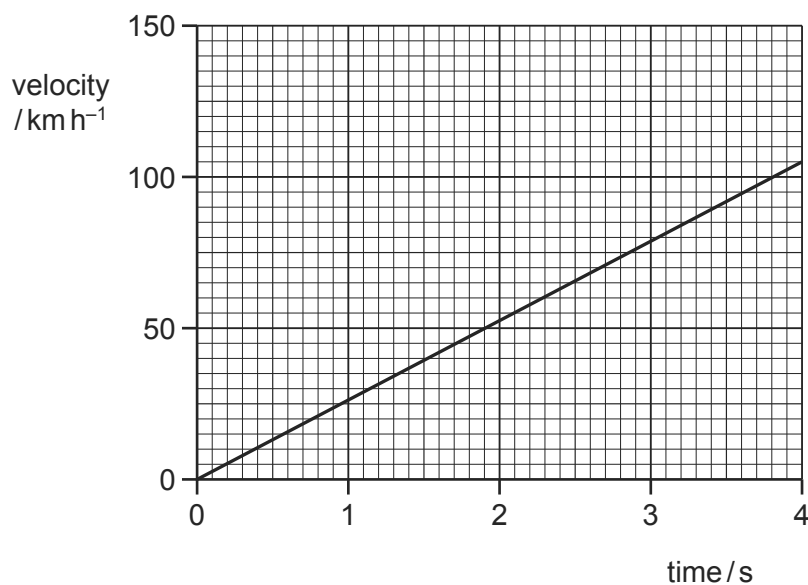

What is the acceleration of the car?

- A**  $210\text{ms}^{-2}$       **B**  $58\text{ms}^{-2}$       **C**  $26\text{ms}^{-2}$       **D**  $7.3\text{ms}^{-2}$

- 83 A raindrop falls vertically from rest in air. The variation with time of the speed of the raindrop is shown in the graph.

9702/13/M/J/15/Q7

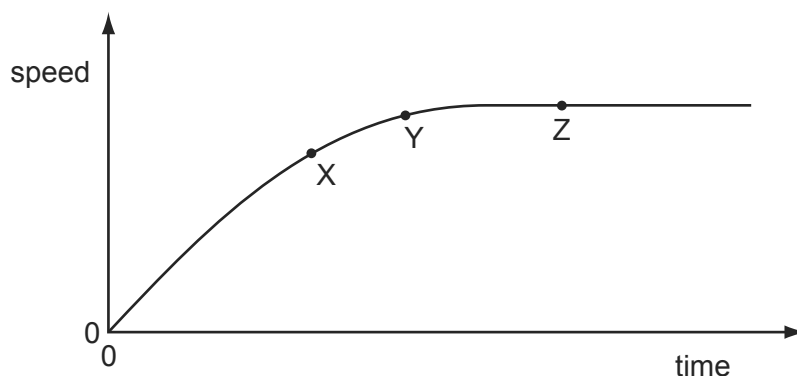

Which statement about the raindrop is correct?

- A** At point X, the raindrop has an acceleration of  $9.81 \text{ m s}^{-2}$ .
- B** At point Z, the force on the raindrop due to air resistance has reached its maximum value and so the acceleration of the raindrop has also reached its maximum value.
- C** At point Z, the force due to air resistance is equal and opposite to the weight of the raindrop and so the speed of the raindrop is zero.
- D** The resultant force on the raindrop at point Y is less than the resultant force on the raindrop at point X.
- 84 A stone is thrown horizontally from the top of a cliff. Air resistance is negligible. 9702/12/M/J/15/Q8

Which graph shows the variation with time of the vertical component of the stone's velocity?

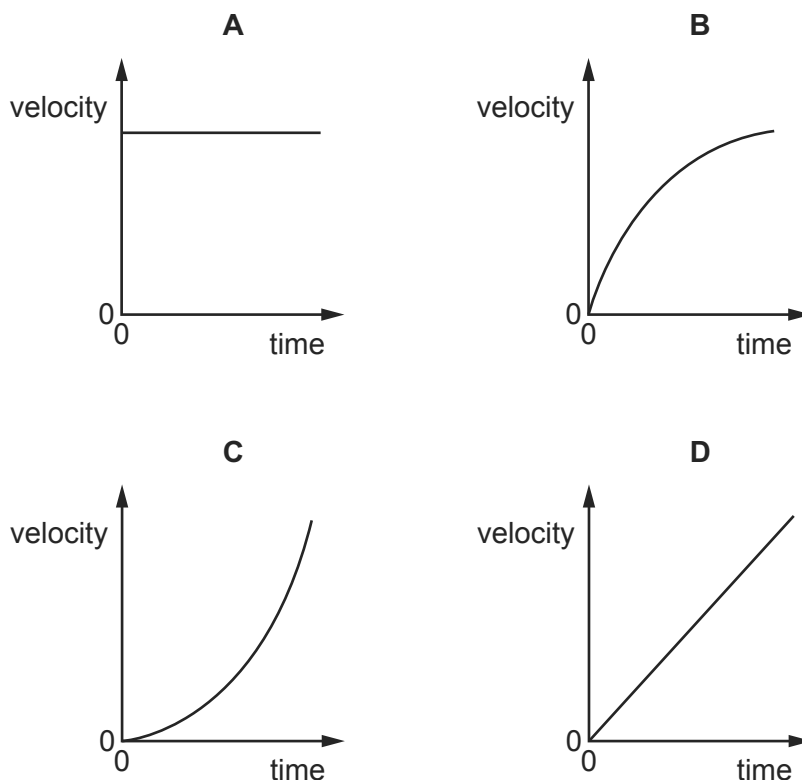

- 85 An astronaut throws a stone with a horizontal velocity near to the Moon's surface. 9702/12/M/J/15/Q12

Which row describes the horizontal and vertical forces acting on the stone after release?

	horizontal force	vertical force
<b>A</b>	constant	constant
<b>B</b>	constant	decreasing
<b>C</b>	zero	constant
<b>D</b>	zero	decreasing

- 86 A sphere is released and falls. Its initial acceleration reduces until it eventually begins to travel at constant terminal velocity. Which displacement-time graph best represents the motion of the sphere?

9702/11/M/J/15/Q7

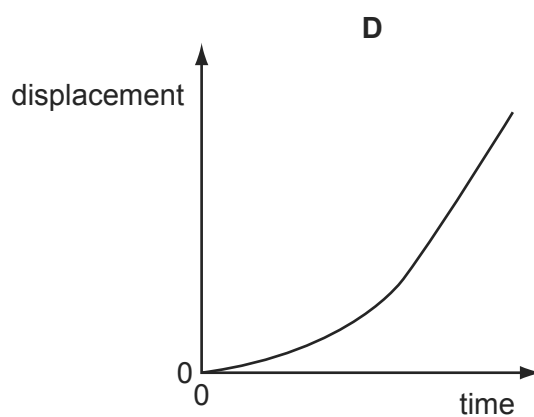
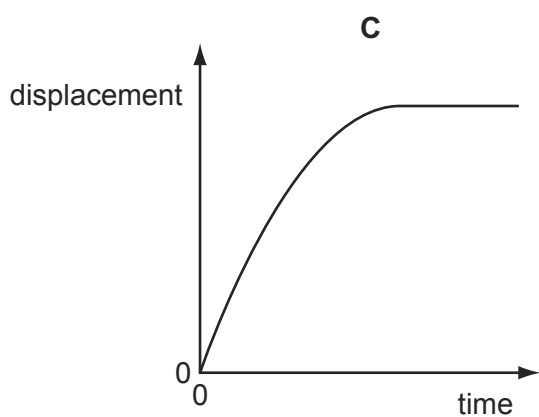
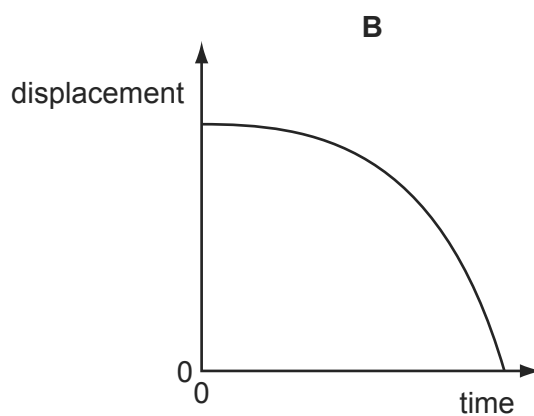
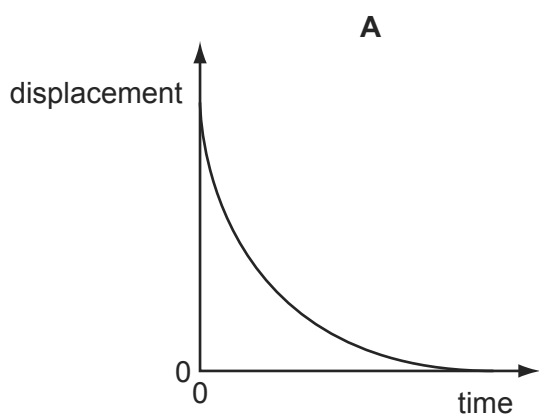

- 1 A motorcycle stunt-rider moving horizontally takes off from a point 1.25 m above the ground, landing 10 m away as shown.

9702/01/M/J/04/Q9

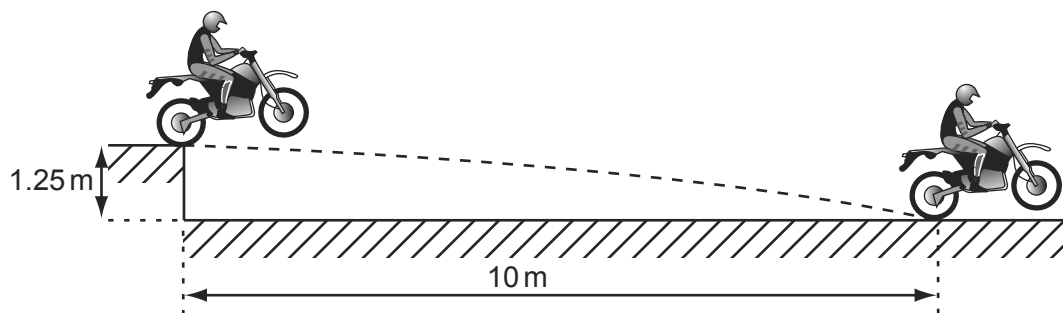

What was the speed at take-off?

- A  $5 \text{ ms}^{-1}$       B  $10 \text{ ms}^{-1}$       C  $15 \text{ ms}^{-1}$       D  $20 \text{ ms}^{-1}$

- 2 A projectile is launched at point O and follows the path OPQRS, as shown. Air resistance may be neglected.

9702/1/O/N/02/Q8

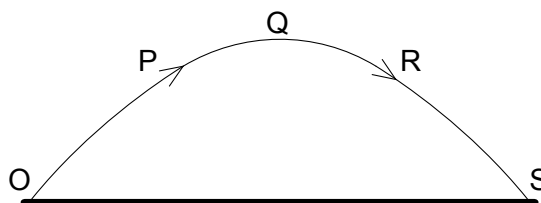

Which statement is true for the projectile when it is at the highest point Q of its path?

- A The horizontal component of the projectile's acceleration is zero.  
 B The horizontal component of the projectile's velocity is zero.  
 C The kinetic energy of the projectile is zero.  
 D The momentum of the projectile is zero.
- 3 In the absence of air resistance, a stone is thrown from P and follows a parabolic path in which the highest point reached is T. The stone reaches point Q just before landing.

9702/01/O/N/04/Q7

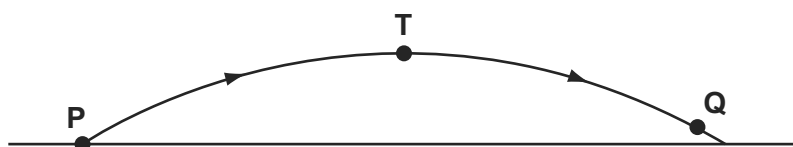

The vertical component of acceleration of the stone is

- A zero at T.  
 B greatest at T.  
 C greatest at Q.  
 D the same at Q as at T.

## Projectiles

- 4 A projectile is fired at an angle  $\alpha$  to the horizontal at a speed  $u$ , as shown.

9702/01/O/N/06/Q9

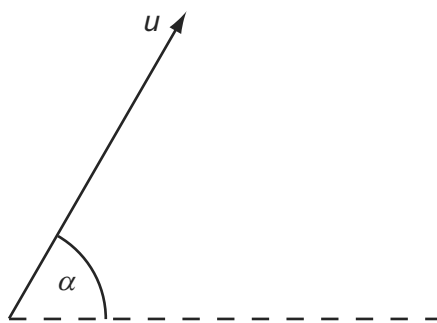

What are the vertical and horizontal components of its velocity after a time  $t$ ? Assume that air resistance is negligible. The acceleration of free fall is  $g$ .

	vertical component	horizontal component
<b>A</b>	$u \sin \alpha$	$u \cos \alpha$
<b>B</b>	$u \sin \alpha - gt$	$u \cos \alpha - gt$
<b>C</b>	$u \sin \alpha - gt$	$u \cos \alpha$
<b>D</b>	$u \cos \alpha$	$u \sin \alpha - gt$

- 5 A projectile is launched at point O and follows the path OPQRS, as shown. Air resistance may be neglected.

9702/01/M/J/05/Q9

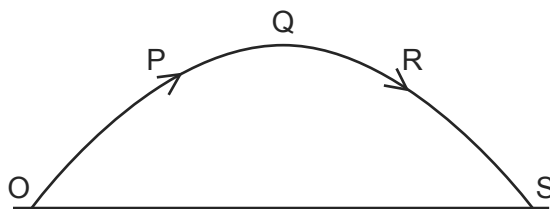

Which statement is true for the projectile when it is at the highest point Q of its path?

- A** The horizontal component of the projectile's acceleration is zero.
- B** The horizontal component of the projectile's velocity is zero.
- C** The kinetic energy of the projectile is zero.
- D** The momentum of the projectile is zero.

- 6 A stone is thrown upwards and follows a curved path.

9702/01/O/N/08/Q7

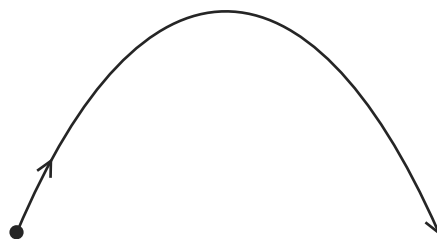

Air resistance is negligible.

Why does the path have this shape?

- A** The stone has a constant horizontal velocity and constant vertical acceleration.  
**B** The stone has a constant horizontal acceleration and constant vertical velocity.  
**C** The stone has a constant upward acceleration followed by a constant downward acceleration.  
**D** The stone has a constant upward velocity followed by a constant downward velocity.
- 7 The diagram shows the path of a golf ball.

9702/01/M/J/09/Q8

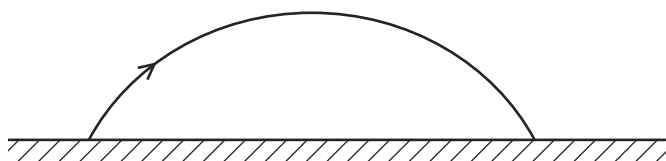

Which row describes changes in the horizontal and vertical components of the golf ball's velocity, when air resistance forces are ignored?

	horizontal	vertical
<b>A</b>	constant deceleration	constant acceleration downwards
<b>B</b>	constant deceleration	acceleration decreases upwards then increases downwards
<b>C</b>	constant velocity	constant acceleration downwards
<b>D</b>	constant velocity	acceleration decreases upwards then increases downwards

- 8 A cannon fires a cannonball with an initial speed  $v$  at an angle  $\alpha$  to the horizontal.

9702/11/M/J/13/Q3

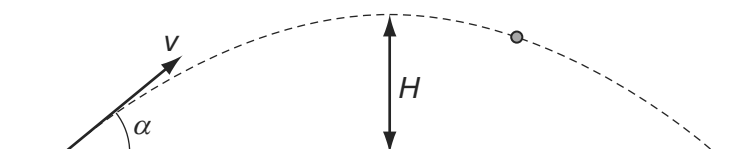

Which equation is correct for the maximum height  $H$  reached?

- A**  $H = \frac{v \sin \alpha}{2g}$     **B**  $H = \frac{g \sin \alpha}{2v}$     **C**  $H = \frac{(v \sin \alpha)^2}{2g}$     **D**  $H = \frac{g^2 \sin \alpha}{2v}$

## Projectiles

- 9 A ball is thrown horizontally in still air from the top of a very tall building. The ball is affected by air resistance. 9702/11/O/N/10/Q7

What happens to the horizontal and to the vertical components of the ball's velocity?

	horizontal component of velocity	vertical component of velocity
<b>A</b>	decreases to zero	increases at a constant rate
<b>B</b>	decreases to zero	increases to a constant value
<b>C</b>	remains constant	increases at a constant rate
<b>D</b>	remains constant	increases to a constant value

- 10 A stone is projected horizontally in a vacuum and moves along the path shown. 9702/01/O/N/05/Q11

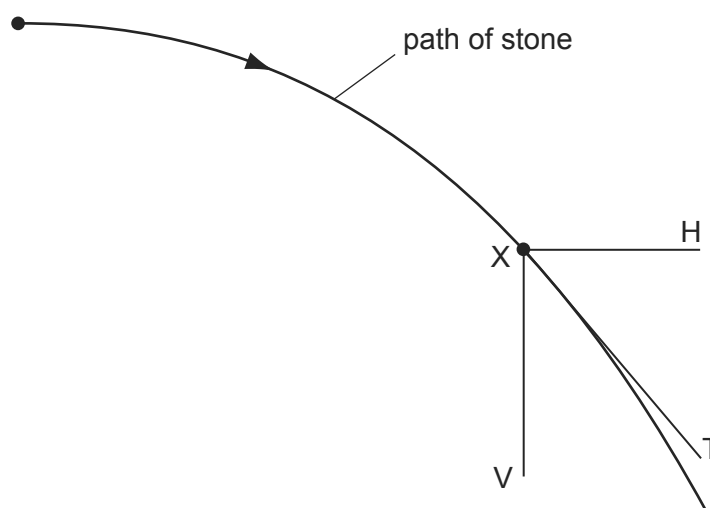

X is a point on this path. XV and XH are vertical and horizontal lines respectively through X. XT is the tangent to the path at X.

Along which directions do forces act on the stone at X?

- A** XV only      **B** XH only      **C** XV and XH      **D** XT only
- 11 A projectile is launched at  $45^\circ$  to the horizontal with initial kinetic energy  $E$ . 9702/11/O/N/14/Q16

Assuming air resistance to be negligible, what will be the kinetic energy of the projectile when it reaches its highest point?

- A**  $0.50E$       **B**  $0.71E$       **C**  $0.87E$       **D**  $E$

- 12 In the absence of air resistance, a stone is thrown from P and follows a parabolic path in which the highest point reached is T. The stone reaches point Q just before landing. 9702/11/M/J/12/Q9

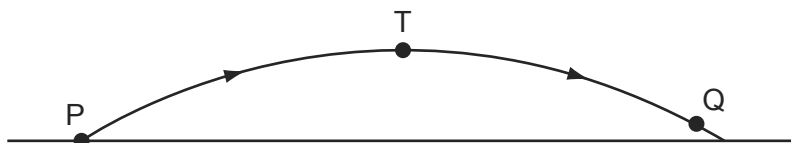

The vertical component of acceleration of the stone is

- A** zero at T.  
**B** larger at T than at Q.  
**C** larger at Q than at T.  
**D** the same at Q as at T.
- 13 A projectile is launched at point O and follows the path OPQRS, as shown. Air resistance may be neglected. 9702/12/M/J/12/Q10

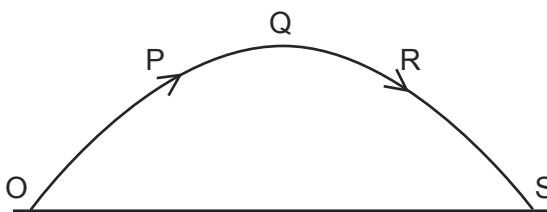

Which statement is true for the projectile when it is at the highest point Q of its path?

- A** The horizontal component of the projectile's acceleration is zero.  
**B** The horizontal component of the projectile's velocity is zero.  
**C** The kinetic energy of the projectile is zero.  
**D** The momentum of the projectile is zero.
- 14 In the absence of air resistance, a stone is thrown from P and follows a parabolic path in which the highest point reached is T. The stone reaches point Q just before landing. 9702/13/M/J/12/Q8

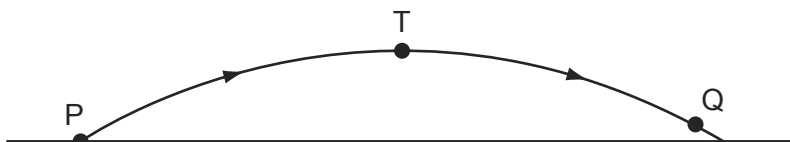

The vertical component of acceleration of the stone is

- A** zero at T.  
**B** larger at T than at Q.  
**C** larger at Q than at T.  
**D** the same at Q as at T.



15 The dotted line shows the path of a competitor in a ski-jumping competition.

9702/12/O/N/12/Q10

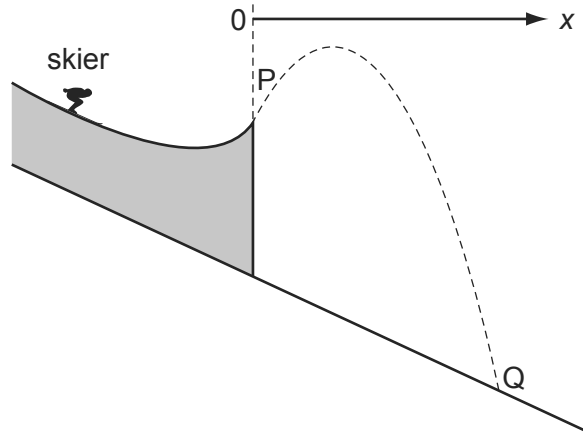

Ignoring air resistance, which graph best represents the variation of his speed  $v$  with the horizontal distance  $x$  covered from the start of his jump at P before landing at Q?

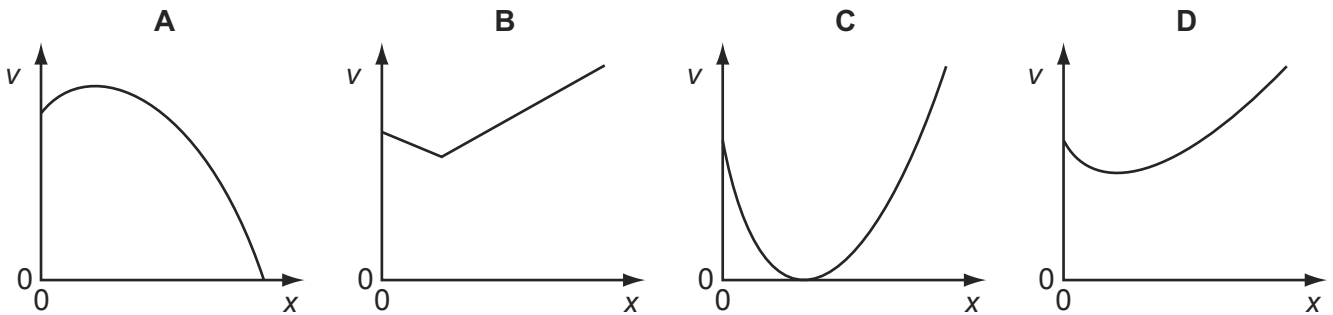

16 A golf ball is hit with the same force and direction on the Earth and on the Moon.

9702/11/O/N/12/Q10

Which diagram best represents the shapes of the paths taken by the golf ball?

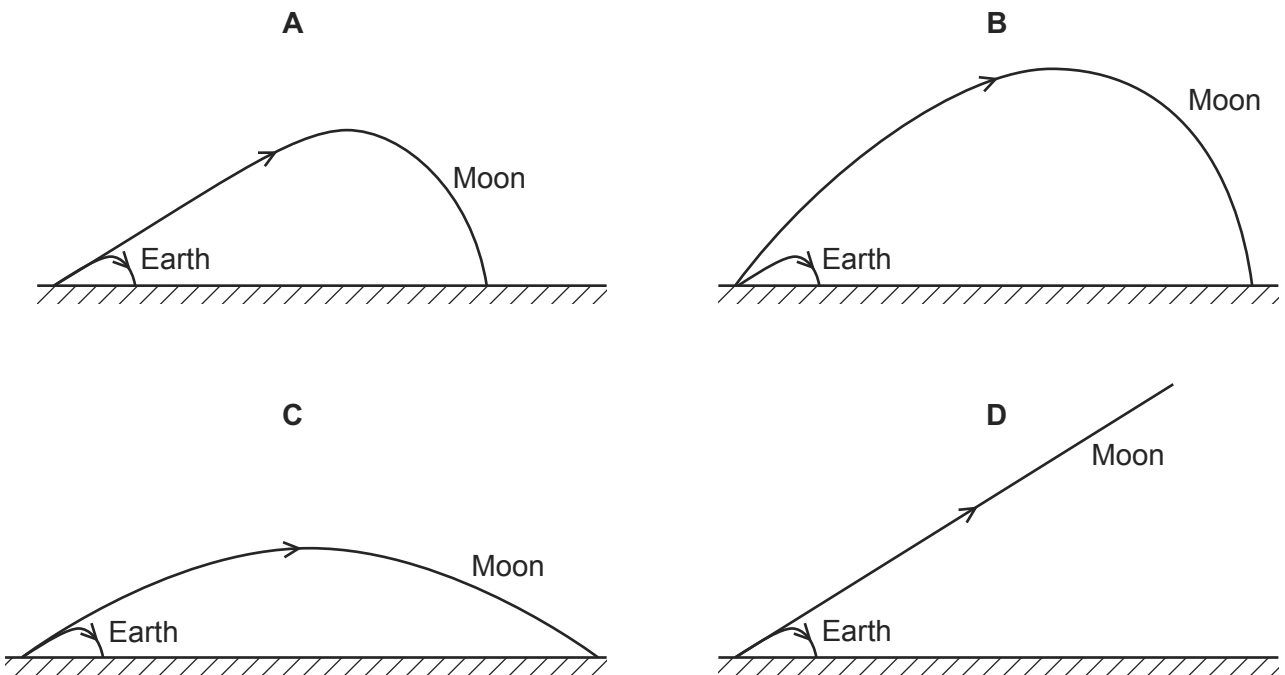

**Projectiles**

- 17 A tennis ball is thrown horizontally in air from the top of a tall building.

9702/11/M/J/14/Q6

If the effect of air resistance is **not** negligible, what happens to the horizontal and vertical components of the ball's velocity?

	horizontal component of velocity	vertical component of velocity
<b>A</b>	constant	constant
<b>B</b>	constant	increases at a constant rate
<b>C</b>	decreases to zero	increases at a constant rate
<b>D</b>	decreases to zero	increases to a maximum value

- 18 A double-ended launching device fires two identical steel balls X and Y at exactly the same time. The diagram shows the initial velocities of the balls. They are both launched horizontally, but Y has greater speed.

9702/13/M/J/13/Q7

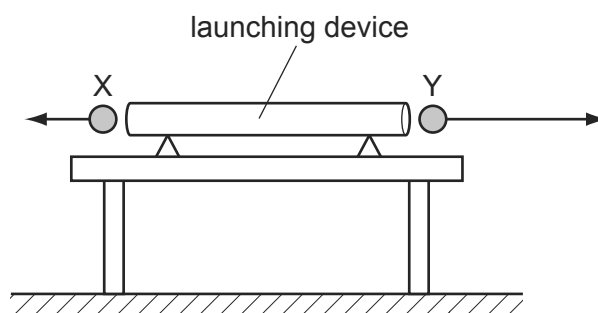

Which statement explains what an observer would see?

- A** Both X and Y reach the ground simultaneously, because air resistance will cause both to have the same final speed.
- B** Both X and Y reach the ground simultaneously, because gravitational acceleration is the same for both.
- C** X reaches the ground before Y, because X lands nearer to the launcher.
- D** Y reaches the ground before X, because Y has greater initial speed.
- 19 An object in air is thrown upwards and towards the left.

9702/11/O/N/13/Q12

Which diagram shows the force(s) acting on the body when it is at its highest point?

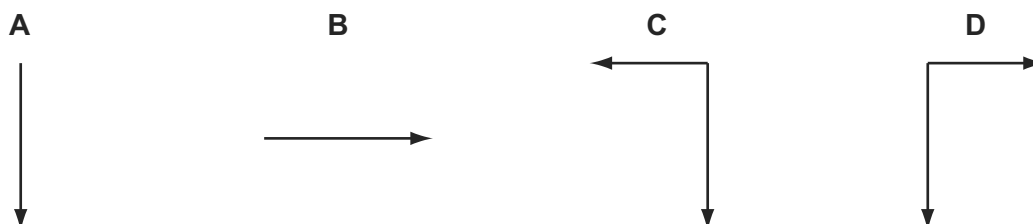

- 20 An astronaut throws a stone with a horizontal velocity near to the Moon's surface. 9702/12/M/J/15/Q12

Which row describes the horizontal and vertical forces acting on the stone after release?

	horizontal force	vertical force
<b>A</b>	constant	constant
<b>B</b>	constant	decreasing
<b>C</b>	zero	constant
<b>D</b>	zero	decreasing

- 21 A stone is thrown horizontally from the top of a cliff. Air resistance is negligible. 9702/12/M/J/15/Q8

Which graph shows the variation with time of the vertical component of the stone's velocity?

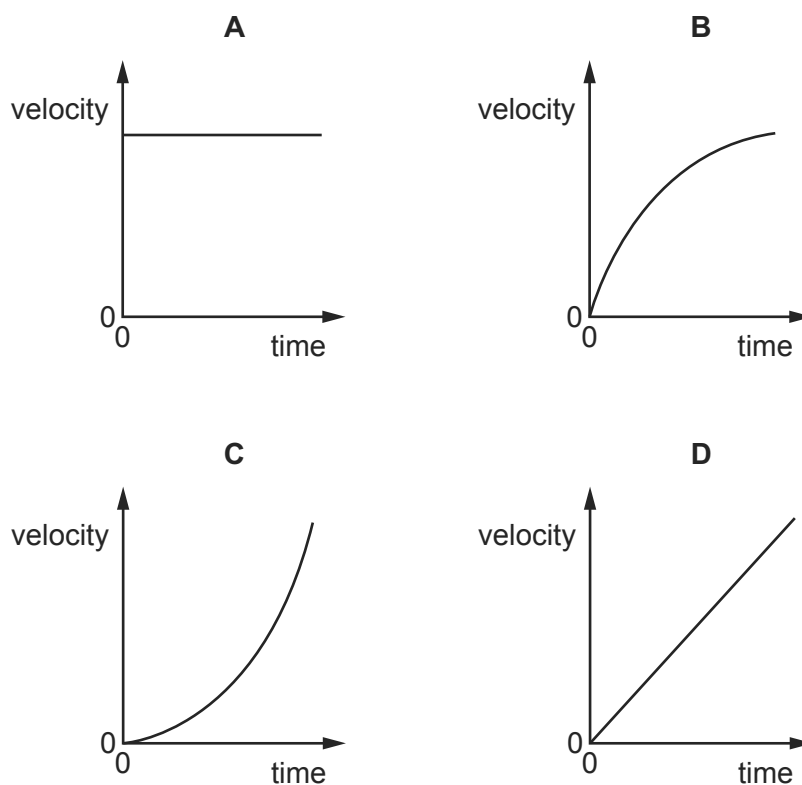

- 1 A wooden block of mass 0.60 kg is on a rough horizontal surface. A force of 12 N is applied to the block and it accelerates at  $4.0 \text{ m s}^{-2}$ .

9702/1/M/J/02/Q10

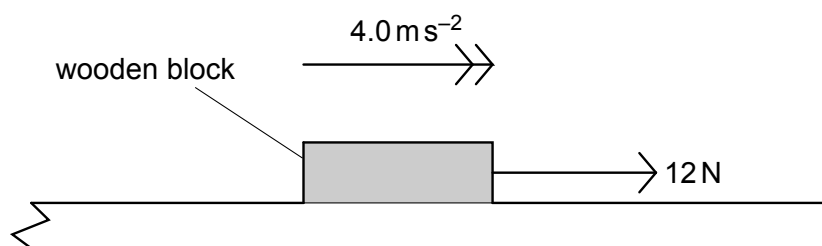

What is the magnitude of the frictional force acting on the block?

- A 2.4 N  
 B 9.6 N  
 C 14 N  
 D 16 N
- 2 A submarine descends vertically at constant velocity. The three forces acting on the submarine are viscous drag, upthrust and weight.

9702/1/M/J/02/Q12

Which relationship between their magnitudes is correct?

- A weight < drag  
 B weight = drag  
 C weight < upthrust  
 D weight > upthrust
- 3 A cylindrical block of wood has a cross-sectional area  $A$  and weight  $W$ . It is totally immersed in water with its axis vertical. The block experiences pressures  $p_t$  and  $p_b$  at its top and bottom surfaces respectively.

9702/1/M/J/02/Q14

Which of the following expressions is equal to the upthrust on the block?

- A  $(p_b - p_t)A + W$   
 B  $(p_b - p_t)$   
 C  $(p_b - p_t)A$   
 D  $(p_b - p_t)A - W$
- 4 A horizontal force of 90 N is used to push a box across a horizontal floor. The frictional force on the box is 50 N.

9702/01/O/N/04/Q16

What is the gain in kinetic energy of the box when it is moved through a distance of 6.0 m?

- A 240 J      B 300 J      C 540 J      D 840 J

- 5 A ruler of length 0.30 m is pivoted at its centre. Equal and opposite forces of magnitude 2.0 N are applied to the ends of the ruler, creating a couple as shown.

9702/1/M/J/02/Q13

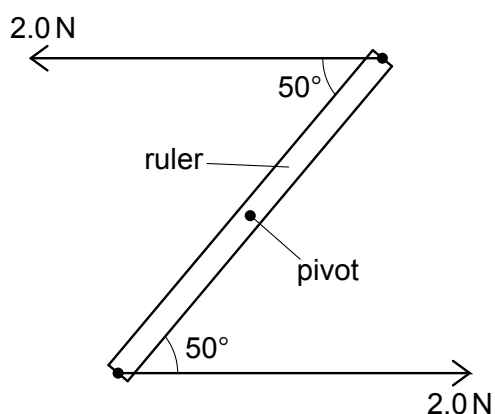

What is the magnitude of the torque of the couple on the ruler when it is in the position shown?

- A 0.23 Nm      B 0.39 Nm      C 0.46 Nm      D 0.60 Nm
- 6 Which of the following pairs of forces, acting on a circular object, constitutes a couple? 9702/1/O/N/02/Q13

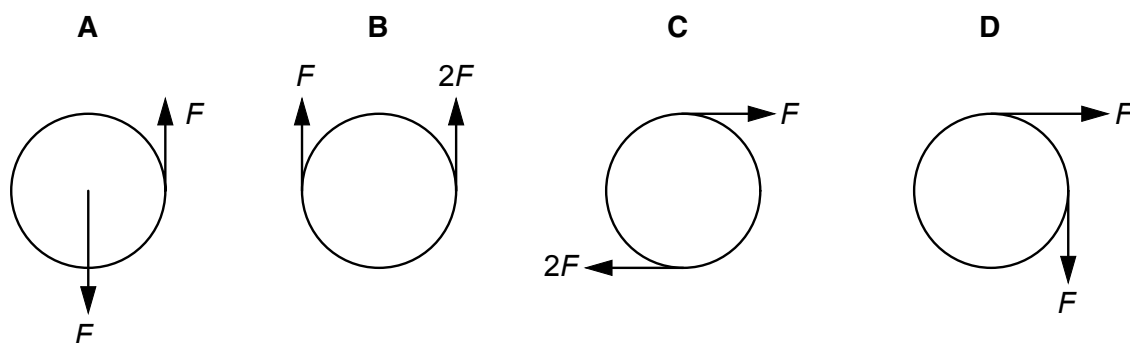

- 7 The diagrams represent systems of coplanar forces acting at a point. The lengths of the force vectors represent the magnitudes of the forces.

9702/1/O/N/02/Q15

Which system of forces is in equilibrium?

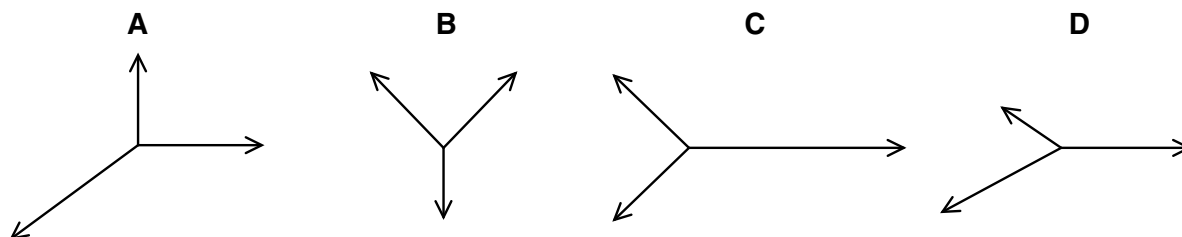

- 8 A uniform metre rule of mass 100 g is supported by a knife-edge at the 40 cm mark and a string at the 100 cm mark. The string passes round a frictionless pulley and carries a mass of 20 g as shown in the diagram.

9702/1/O/N/02/Q14

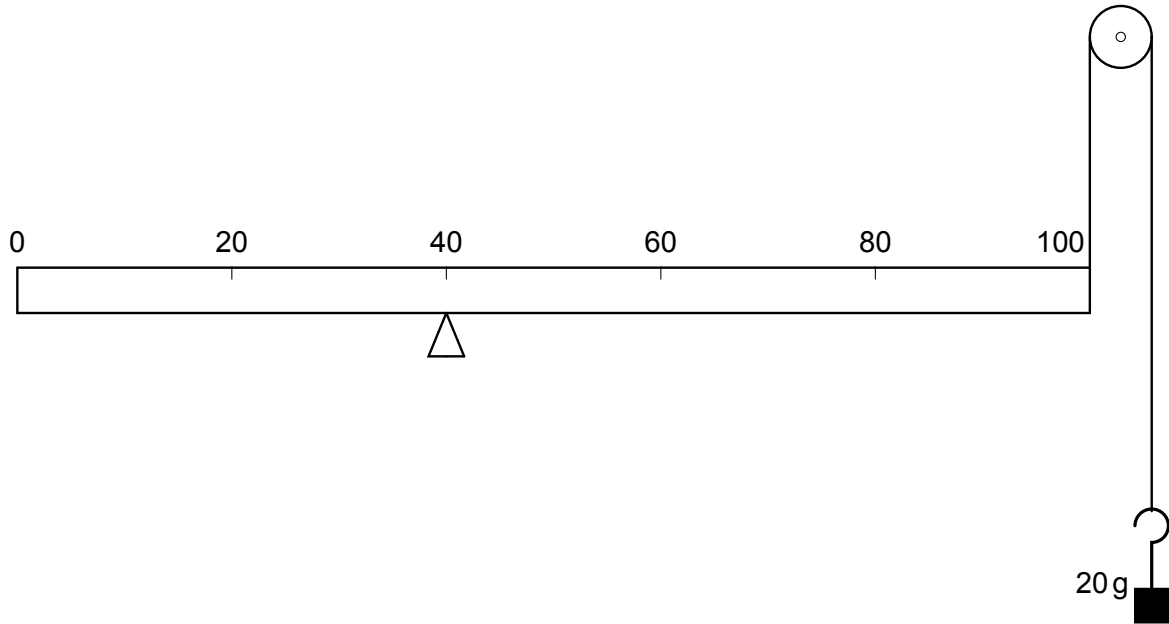

At which mark on the rule must a 50 g mass be suspended so that the rule balances?

- A 4 cm      B 36 cm      C 44 cm      D 96 cm
- 9 A car with front-wheel drive accelerates in the direction shown.

9702/01/M/J/03/Q11

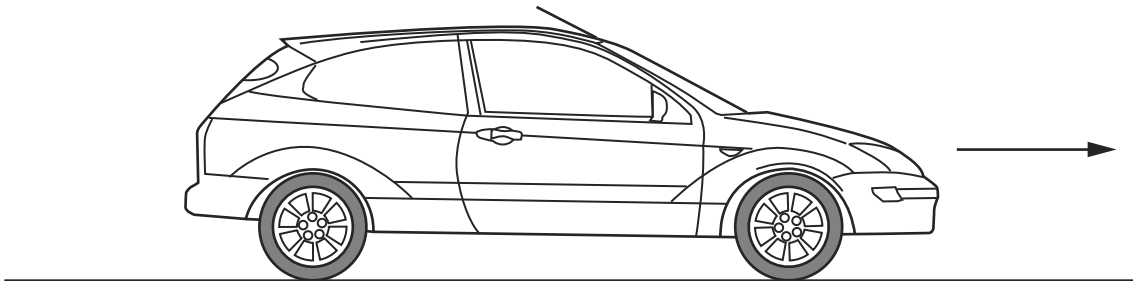

Which diagram best shows the direction of the total force exerted by the road on the front wheels?

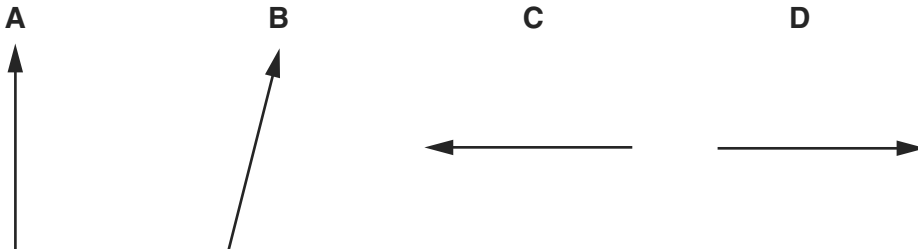

- 10 The diagram shows four forces applied to a circular object.

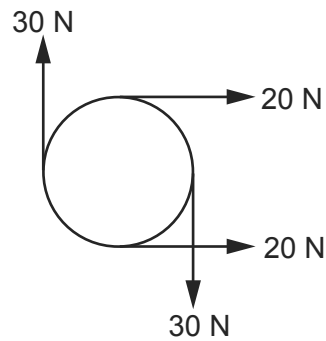

Which of the following describes the resultant force and resultant torque on the object?

	resultant force	resultant torque
<b>A</b>	zero	zero
<b>B</b>	zero	non-zero
<b>C</b>	non-zero	zero
<b>D</b>	non-zero	non-zero

- 11 A balloon is acted upon by three forces, weight, upthrust and sideways force due to the wind, as shown in the diagram.

9702/01/M/J/03/Q14

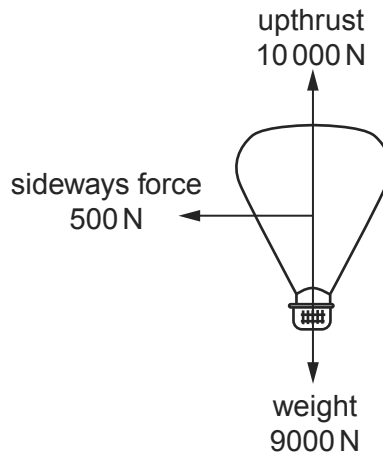

What is the vertical component of the resultant force on the balloon?

- A** 500 N      **B** 1000 N      **C** 10 000 N      **D** 10 500 N
- 12 A steel sphere is dropped vertically onto a horizontal metal plate. The sphere hits the plate with a speed  $u$ , leaves it at a speed  $v$ , and rebounds vertically to half of its original height. 9702/11/M/J/11/Q14

Which expression gives the value of  $\frac{v}{u}$ ?

- A**  $\frac{1}{2^2}$       **B**  $\frac{1}{2}$       **C**  $\frac{1}{\sqrt{2}}$       **D**  $1 - \frac{1}{\sqrt{2}}$

- 13 A ball falls from rest through air and eventually reaches a constant velocity.

For this fall, forces  $X$  and  $Y$  vary with time as shown.

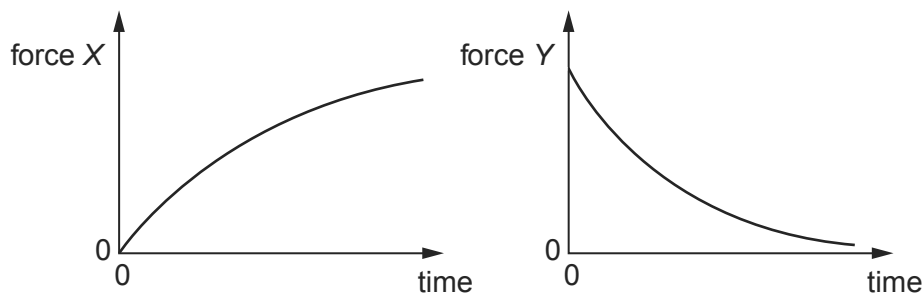

What are forces  $X$  and  $Y$ ?

	force $X$	force $Y$
<b>A</b>	air resistance	resultant force
<b>B</b>	air resistance	weight
<b>C</b>	upthrust	resultant force
<b>D</b>	upthrust	weight

- 14 A hinged door is held closed in the horizontal position by a cable.

Three forces act on the door: the weight  $W$  of the door, the tension  $T$  in the cable, and the force  $H$  at the hinge.

9702/01/O/N/03/Q16

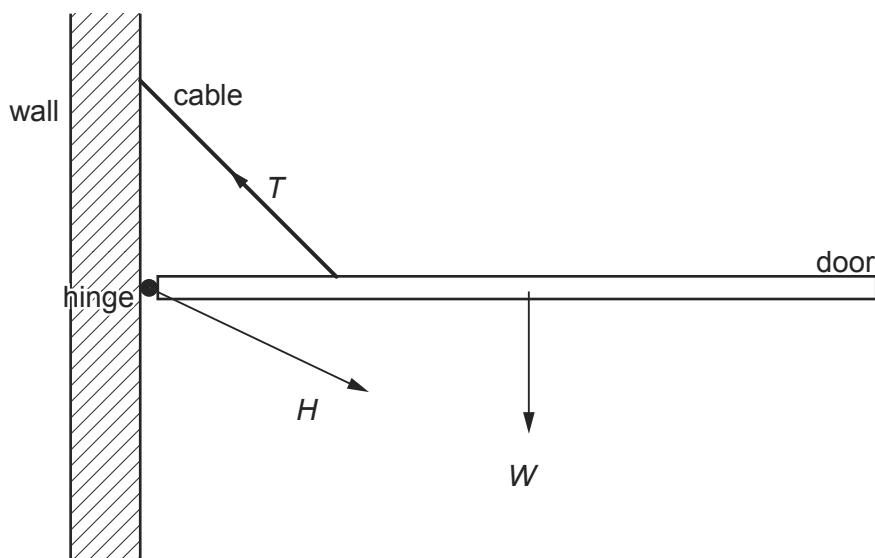

Which list gives the three forces in **increasing** order of magnitude?

- A**  $H, T, W$       **B**  $T, H, W$       **C**  $W, H, T$       **D**  $W, T, H$



- 15 A spanner is used to tighten a nut as shown.

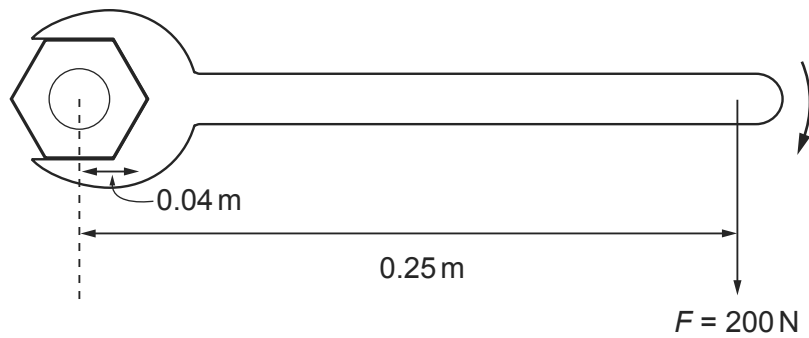

A force  $F$  is applied at right-angles to the spanner at a distance of 0.25 m from the centre of the nut. When the nut is fully tightened, the applied force is 200 N.

What is the resistive torque, in an anticlockwise direction, preventing further tightening?

- A 8 Nm  
 B 25 Nm  
 C 50 Nm  
 D 800 Nm
- 16 Two parallel forces, each of magnitude  $F$ , act on a body as shown.

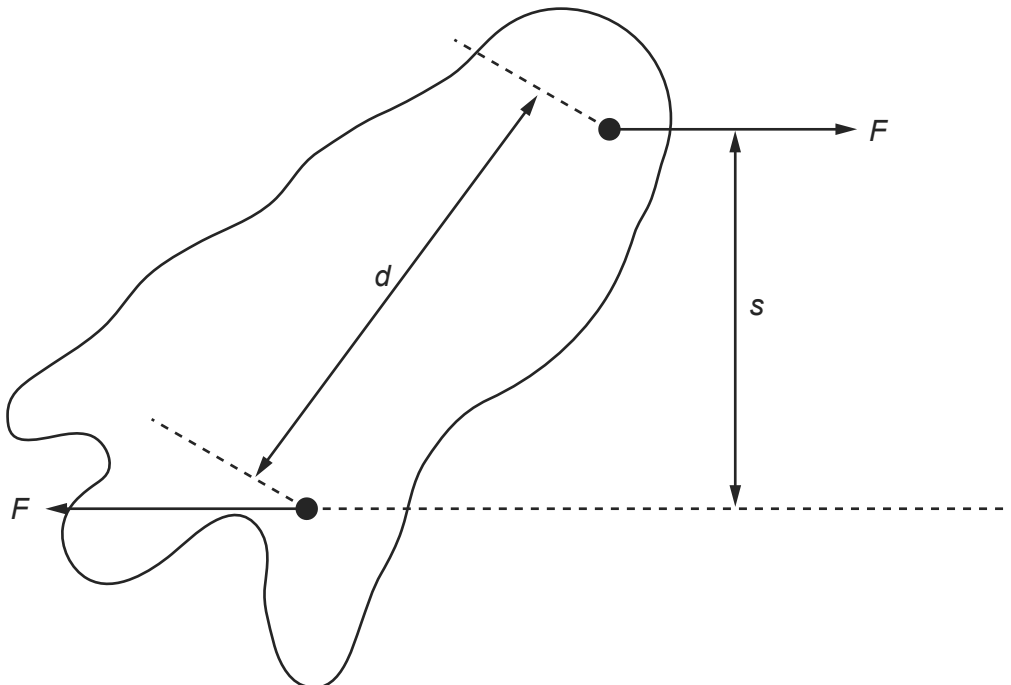

What is the magnitude of the torque on the body produced by these forces?

- A  $Fd$     B  $Fs$     C  $2Fd$     D  $2Fs$

- 17 A force  $F$  is applied to a freely moving object. At one instant of time, the object has velocity  $v$  and acceleration  $a$ .

9702/01/O/N/03/Q15

Which quantities **must** be in the same direction?

- A  $a$  and  $v$  only
- B  $a$  and  $F$  only
- C  $v$  and  $F$  only
- D  $v$ ,  $F$  and  $a$

- 18 A ball falls vertically and bounces on the ground.

9702/01/M/J/04/Q10

The following statements are about the forces acting while the ball is in contact with the ground.

Which statement is correct?

- A The force that the ball exerts on the ground is always equal to the weight of the ball.
  - B The force that the ball exerts on the ground is always equal in magnitude and opposite in direction to the force the ground exerts on the ball.
  - C The force that the ball exerts on the ground is always less than the weight of the ball.
  - D The weight of the ball is always equal in magnitude and opposite in direction to the force that the ground exerts on the ball.
- 19 An object, immersed in a liquid in a tank, experiences an upthrust.

9702/01/M/J/04/Q12

What is the physical reason for this upthrust?

- A The density of the body differs from that of the liquid.
  - B The density of the liquid increases with depth.
  - C The pressure in the liquid increases with depth.
  - D The value of  $g$  in the liquid increases with depth.
- 20 A long uniform beam is pivoted at one end. A force of 300 N is applied to hold the beam horizontally.

9702/01/O/N/04/Q13

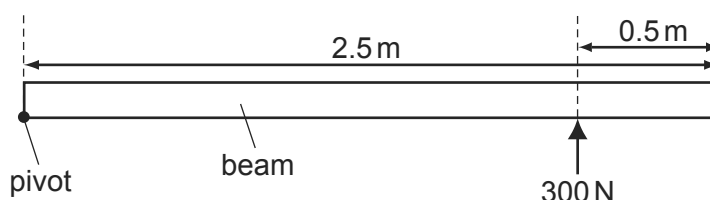

What is the weight of the beam?

- A 300 N
- B 480 N
- C 600 N
- D 960 N

- 21 A uniform beam of weight 50 N is 3.0 m long and is supported on a pivot situated 1.0 m from one end. When a load of weight  $W$  is hung from that end, the beam is in equilibrium, as shown in the diagram.

9702/01/M/J/04/Q13

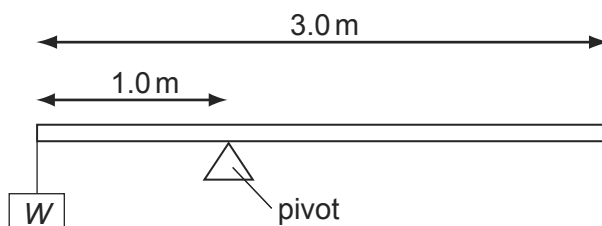

What is the value of  $W$ ?

- A** 25 N      **B** 50 N      **C** 75 N      **D** 100 N
- 22 The diagram shows a sign of weight 20 N suspended from a pole, attached to a wall. The pole is kept in equilibrium by a wire attached at point X of the pole.

9702/01/M/J/04/Q14

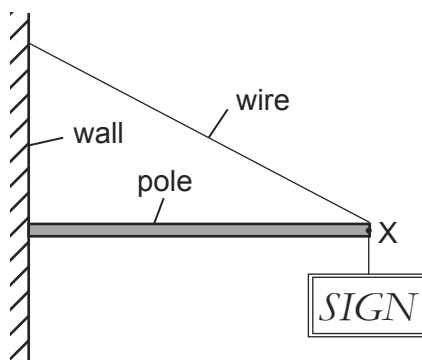

The force exerted by the pole at point X is  $F$ , and the tension in the wire is 40 N.

Which diagram represents the three forces acting at point X?

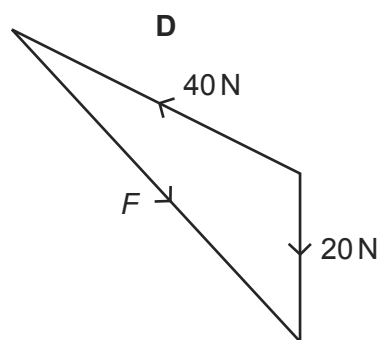
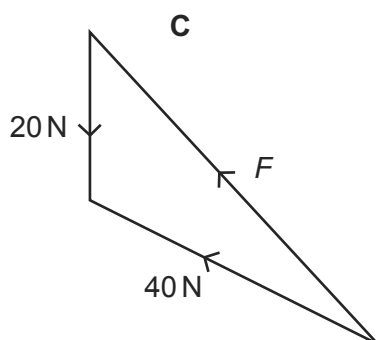
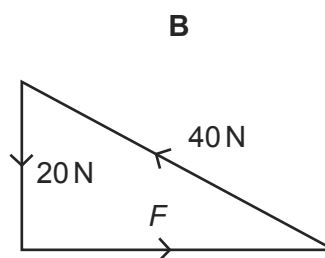
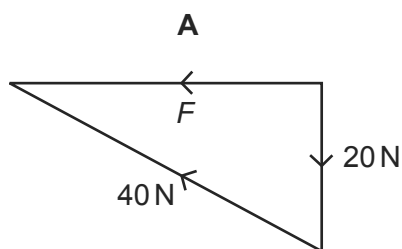

23 Which two vector diagrams represent forces in equilibrium?

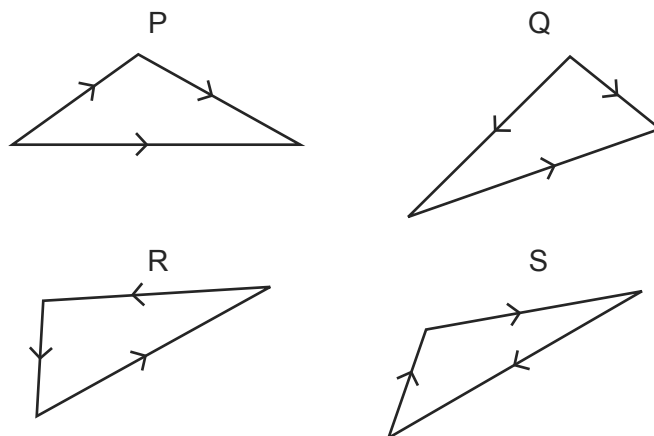

- A P and Q
- B Q and R
- C R and S
- D S and P

24 What is the centre of gravity of an object?

9702/01/M/J/05/Q12

- A the geometrical centre of the object
- B the point about which the total torque is zero
- C the point at which the weight of the object may be considered to act
- D the point through which gravity acts

25 An L-shaped rigid lever arm is pivoted at point P.

9702/01/M/J/05/Q13

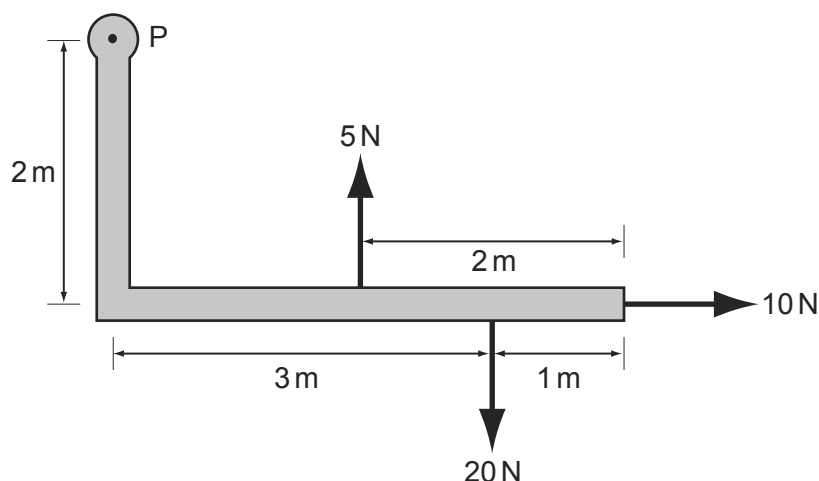

Three forces act on the lever arm, as shown in the diagram.

What is the magnitude of the resultant moment of these forces about point P?

- A 30 Nm
- B 35 Nm
- C 50 Nm
- D 90 Nm

- 26 A uniform beam of weight 100 N is pivoted at P as shown. Weights of 10 N and 20 N are attached to its ends.

9702/01/O/N/05/Q12

The length of the beam is marked off at 0.1 m intervals.

At which point should a further weight of 20 N be attached to achieve equilibrium?

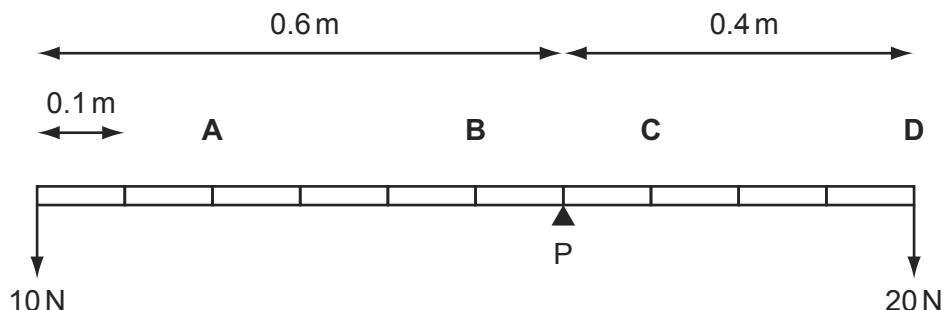

- 27 The diagram shows four forces applied to a circular object.

9702/01/O/N/05/Q13

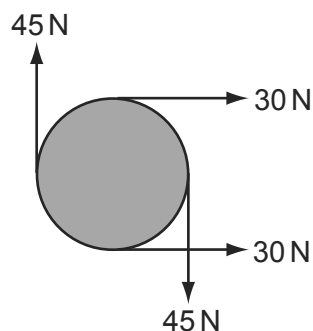

Which of the following describes the resultant force and resultant torque on the object?

9702/01/O/N/05

	resultant force	resultant torque
<b>A</b>	non-zero	non-zero
<b>B</b>	non-zero	zero
<b>C</b>	zero	non-zero
<b>D</b>	zero	zero

- 28 A cyclist is riding at a steady speed on a level road.

9702/01/M/J/06/Q10

According to Newton's third law of motion, what is equal and opposite to the backward push of the back wheel on the road?

- A** the force exerted by the cyclist on the pedals
- B** the forward push of the road on the back wheel
- C** the tension in the cycle chain
- D** the total air resistance and friction force

- 29 The diagrams show three forces acting on a body.

9702/01/M/J/06/Q13

In which diagram is the body in equilibrium?

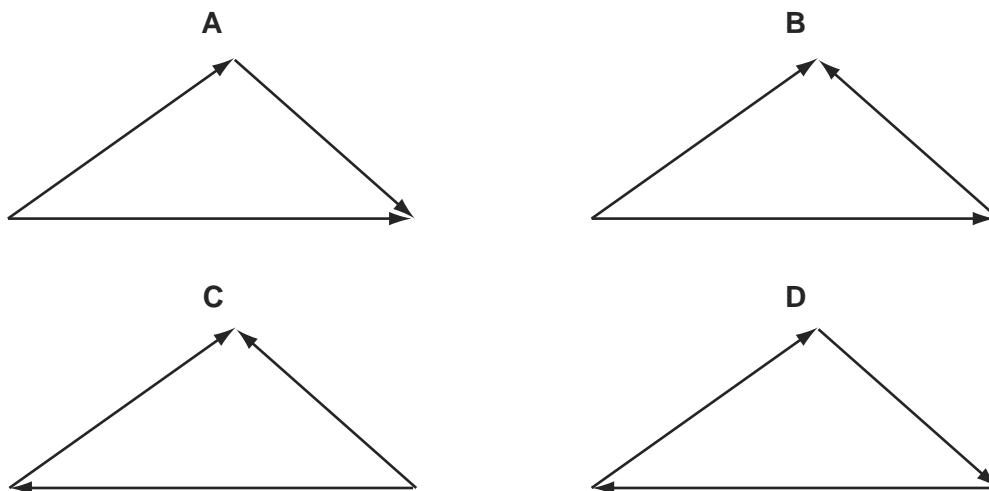

- 30 Two 8.0 N forces act at each end of a beam of length 0.60 m. The forces are parallel and act in opposite directions. The angle between the forces and the beam is  $60^\circ$ .

9702/01/M/J/07/Q13

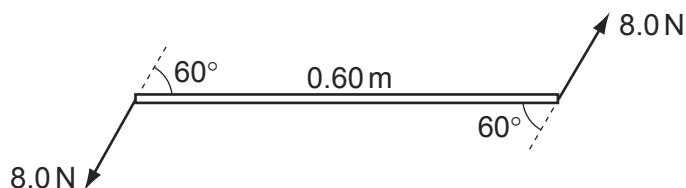

What is the torque of the couple exerted on the beam?

- A** 2.4 Nm      **B** 4.2 Nm      **C** 4.8 Nm      **D** 9.6 Nm
- 31 A block of mass 0.60 kg is on a rough horizontal surface. A force of 12 N is applied to the block and it accelerates at  $4.0 \text{ m s}^{-2}$ .

9702/01/O/N/07/Q10

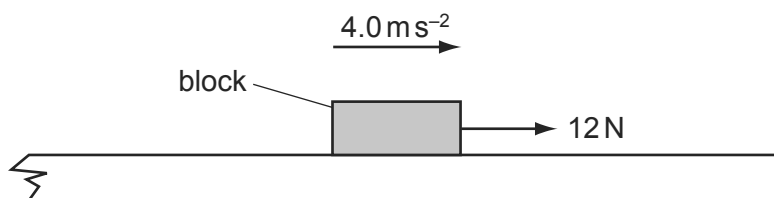

What is the magnitude of the frictional force acting on the block?

- A** 2.4 N      **B** 5.3 N      **C** 6.7 N      **D** 9.6 N

- 32 A force  $F$  is applied to a beam at a distance  $d$  from a pivot. The force acts at an angle  $\theta$  to a line perpendicular to the beam.

9702/01/M/J/06/Q14

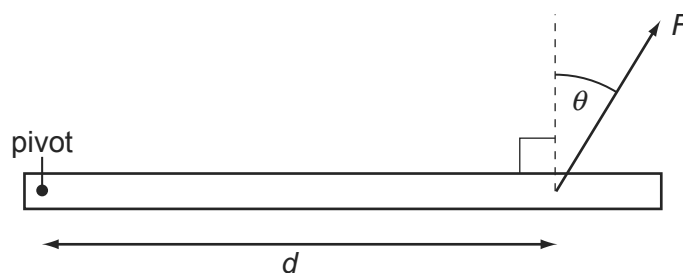

Which combination will cause the largest turning effect about the pivot?

	$F$	$d$	$\theta$
<b>A</b>	large	large	large
<b>B</b>	large	large	small
<b>C</b>	small	small	large
<b>D</b>	small	large	small

- 33 A rigid uniform bar of length 2.4 m is pivoted horizontally at its mid-point.

9702/01/M/J/06/Q15

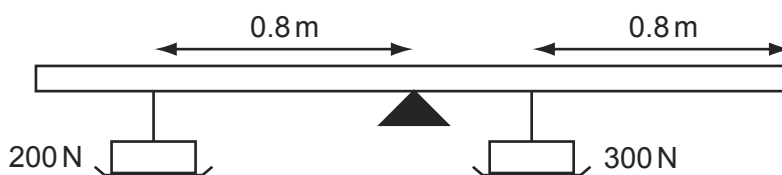

Weights are hung from two points of the bar as shown in the diagram. To maintain horizontal equilibrium, a couple is applied to the bar.

What is the torque and direction of this couple?

- A** 40 N m clockwise  
**B** 40 N m anticlockwise  
**C** 80 N m clockwise  
**D** 80 N m anticlockwise
- 34 A ball is falling at terminal speed in still air. The forces acting on the ball are upthrust, viscous drag and weight.

9702/01/M/J/08/Q12

What is the order of increasing magnitude of these three forces?

- A** upthrust  $\rightarrow$  viscous drag  $\rightarrow$  weight  
**B** viscous drag  $\rightarrow$  upthrust  $\rightarrow$  weight  
**C** viscous drag  $\rightarrow$  weight  $\rightarrow$  upthrust  
**D** weight  $\rightarrow$  upthrust  $\rightarrow$  viscous drag

- 35 A rigid circular disc of radius  $r$  has its centre at  $X$ . A number of forces of equal magnitude  $F$  act at the edge of the disc. All the forces are in the plane of the disc.

9702/01/O/N/06/Q14

Which arrangement of forces provides a moment of magnitude  $2Fr$  about  $X$ ?

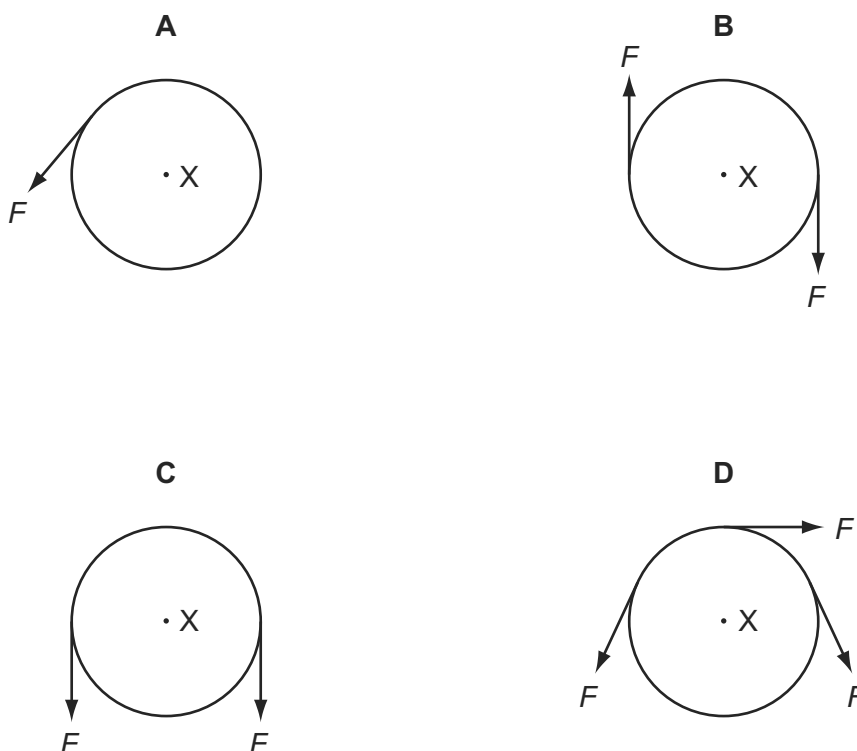

- 36 Three coplanar forces, each of magnitude  $10\text{ N}$ , act through the same point of a body in the directions shown.

9702/01/O/N/06/Q15

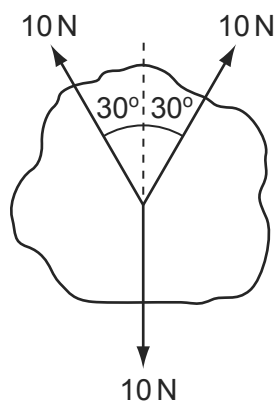

What is the magnitude of the resultant force?

- A**  $0\text{ N}$       **B**  $1.3\text{ N}$       **C**  $7.3\text{ N}$       **D**  $10\text{ N}$
- 37 A supermarket trolley, total mass  $30\text{ kg}$ , is moving at  $3.0\text{ m s}^{-1}$ . A retarding force of  $60\text{ N}$  is applied to the trolley for  $0.50\text{ s}$  in the opposite direction to the trolley's initial velocity.

9702/12/O/N/09/Q9

What is the trolley's new velocity after the application of the force?

- A**  $1.0\text{ m s}^{-1}$       **B**  $1.5\text{ m s}^{-1}$       **C**  $2.0\text{ m s}^{-1}$       **D**  $2.8\text{ m s}^{-1}$

## Forces



- 38 A car with front-wheel drive accelerates in the direction shown.

9702/01/O/N/07/Q11

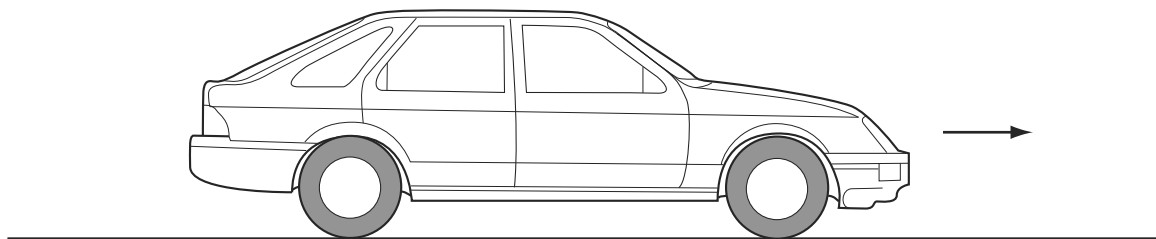

Which diagram best shows the direction of the total force exerted by the road on the front wheels?

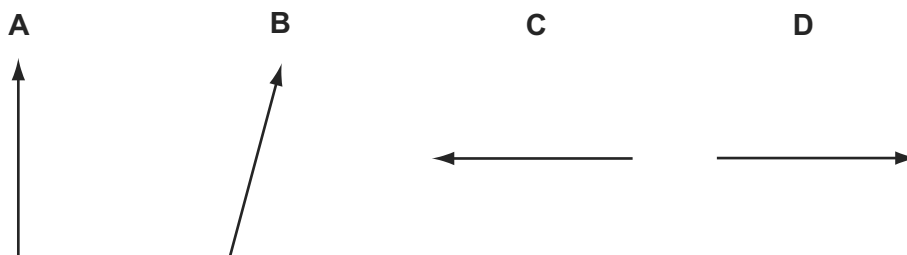

- 39 Which two vector diagrams represent forces in equilibrium?

9702/01/O/N/07/Q13

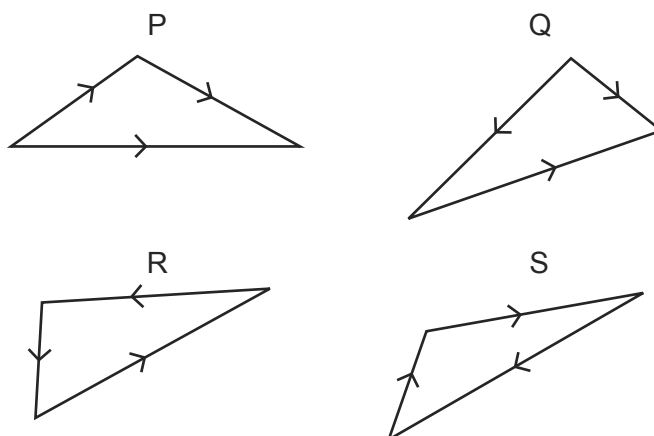

- A** P and Q      **B** Q and R      **C** R and S      **D** S and P

- 40 The diagram shows a plan view of a door which requires a moment of 12 N m to open it.

9702/01/O/N/07/Q14

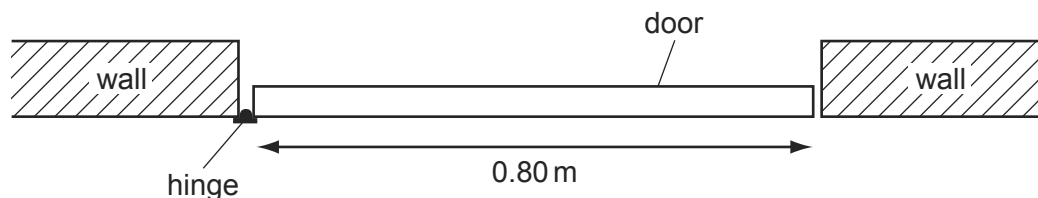

What is the minimum force that must be applied at the door's midpoint to ensure it opens?

- A** 4.8 N      **B** 9.6 N      **C** 15 N      **D** 30 N

- 41 A car of mass 750 kg has a horizontal driving force of 2.0 kN acting on it. It has a forward horizontal acceleration of  $2.0 \text{ m s}^{-2}$ . 9702/01/M/J/08/Q11

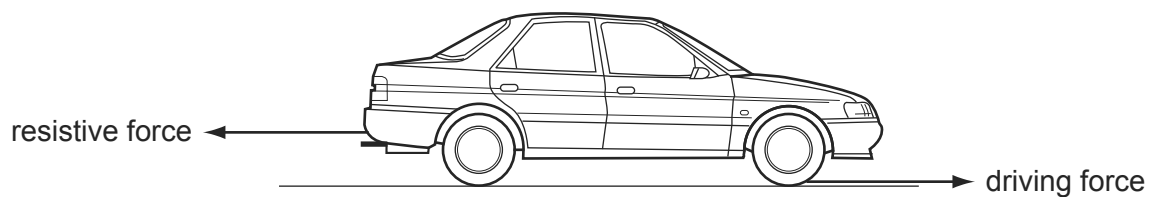

What is the resistive force acting horizontally?

- A** 0.5 kN      **B** 1.5 kN      **C** 2.0 kN      **D** 3.5 kN
- 42 Two rigid rods, XZ and YZ, are fixed to a vertical wall at points X and Y. 9702/01/M/J/08/Q13

A load of weight  $W$  is hung from point Z.

The load is not moving.

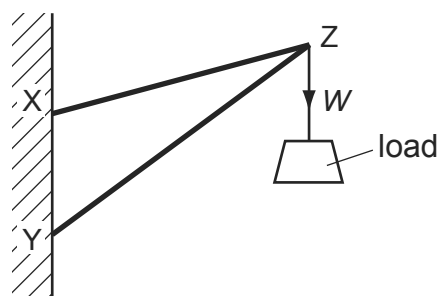

Which diagram shows the forces acting at point Z?

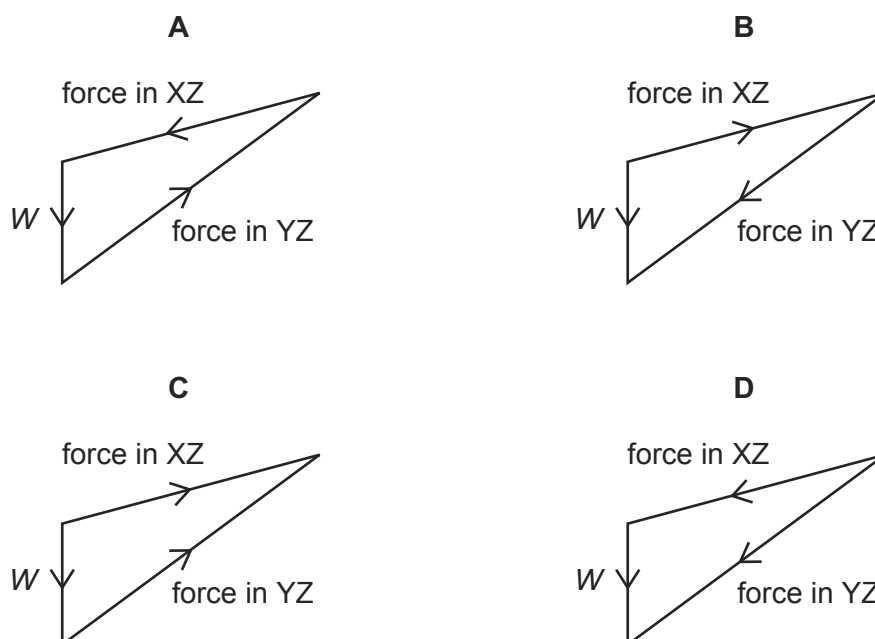

- 43 A uniform ladder rests against a vertical wall where there is negligible friction. The bottom of the ladder rests on rough ground where there is friction. The top of the ladder is at a height  $h$  above the ground and the foot of the ladder is at a distance  $2a$  from the wall.

9702/01/M/J/08/Q14

The diagram shows the forces which act on the ladder.

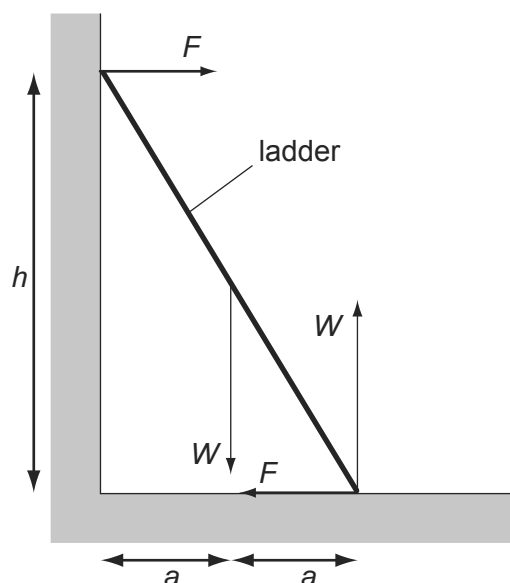

Which equation is formed by taking moments?

- |                          |                           |
|--------------------------|---------------------------|
| <b>A</b> $Wa + Fh = 2Wa$ | <b>B</b> $Fa + Wa = Fh$   |
| <b>C</b> $Wa + 2Wa = Fh$ | <b>D</b> $Wa - 2Wa = 2Fh$ |
- 44 A positive charge experiences a force  $F$  when placed at point X in a uniform electric field.

9702/01/M/J/08/Q16

The charge is then moved from point X to point Y.

Distances  $r$  and  $s$  are shown on the diagram.

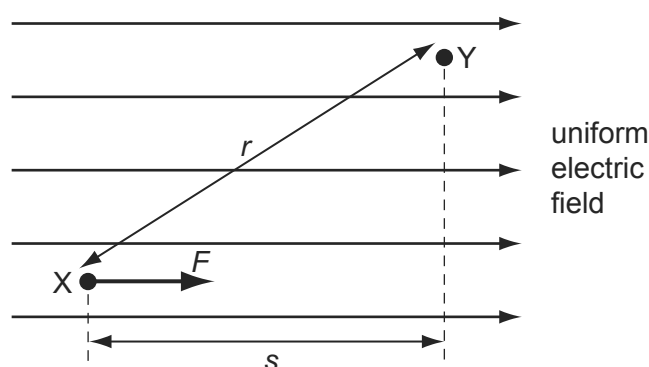

What is the change in the potential energy of the charge?

- |                            |
|----------------------------|
| <b>A</b> decreases by $Fs$ |
| <b>B</b> increases by $Fs$ |
| <b>C</b> decreases by $Fr$ |
| <b>D</b> increases by $Fr$ |

- 45 A submarine is in equilibrium in a fully submerged position.

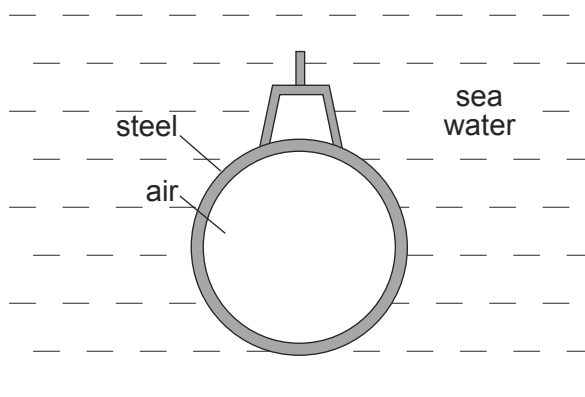

What causes the upthrust on the submarine?

- A** The air in the submarine is less dense than sea water.  
**B** The sea water exerts a greater upward force on the submarine than the weight of the steel.  
**C** The submarine displaces its own volume of sea water.  
**D** There is a difference in water pressure acting on the top and bottom of the submarine.
- 46 A box of mass 8.0 kg rests on a horizontal, rough surface. A string attached to the box passes over a smooth pulley and supports a 2.0 kg mass at its other end.

9702/01/O/N/08/Q11

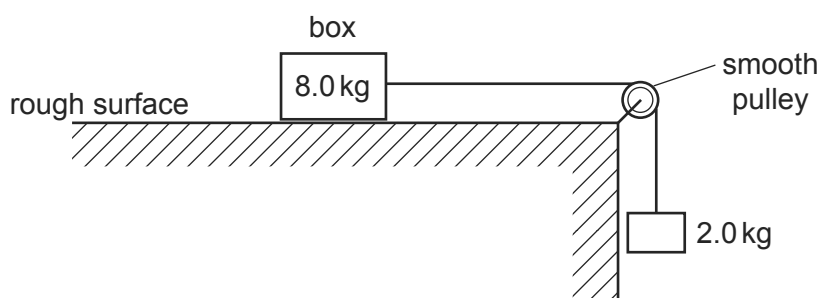

When the box is released, a friction force of 6.0 N acts on it.

What is the acceleration of the box?

- A**  $1.4 \text{ ms}^{-2}$       **B**  $1.7 \text{ ms}^{-2}$       **C**  $2.0 \text{ ms}^{-2}$       **D**  $2.5 \text{ ms}^{-2}$
- 47 An object, made from two equal masses joined by a light rod, falls with uniform speed through air. The rod remains horizontal.

9702/01/M/J/09/Q12

Which statement about the equilibrium of the system is correct?

- A** It is not in equilibrium because it is falling steadily.  
**B** It is not in equilibrium because it is in motion.  
**C** It is not in equilibrium because there is a resultant torque.  
**D** It is in equilibrium because there is no resultant force and no resultant torque.

- 48 A ball falls vertically and bounces on the ground.

9702/01/O/N/08/Q9

The following statements are about the forces acting while the ball is in contact with the ground.

Which statement is correct?

- A** The force that the ball exerts on the ground is always equal to the weight of the ball.
- B** The force that the ball exerts on the ground is always equal in magnitude and opposite in direction to the force the ground exerts on the ball.
- C** The force that the ball exerts on the ground is always less than the weight of the ball.
- D** The weight of the ball is always equal in magnitude and opposite in direction to the force that the ground exerts on the ball.
- 49 A wooden block rests on a rough board. The end of the board is then raised until the block slides down the plane of the board at constant velocity  $v$ .

9702/01/O/N/08/Q12

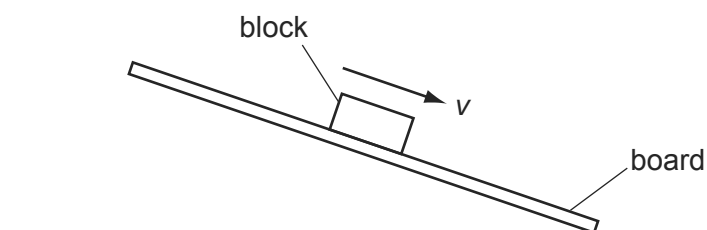

Which row describes the forces acting on the block when sliding with constant velocity?

	frictional force on block	resultant force on block
<b>A</b>	down the plane	down the plane
<b>B</b>	down the plane	zero
<b>C</b>	up the plane	down the plane
<b>D</b>	up the plane	zero

- 50 Which pair of forces acts as a couple on the circular object?

9702/01/O/N/08/Q14

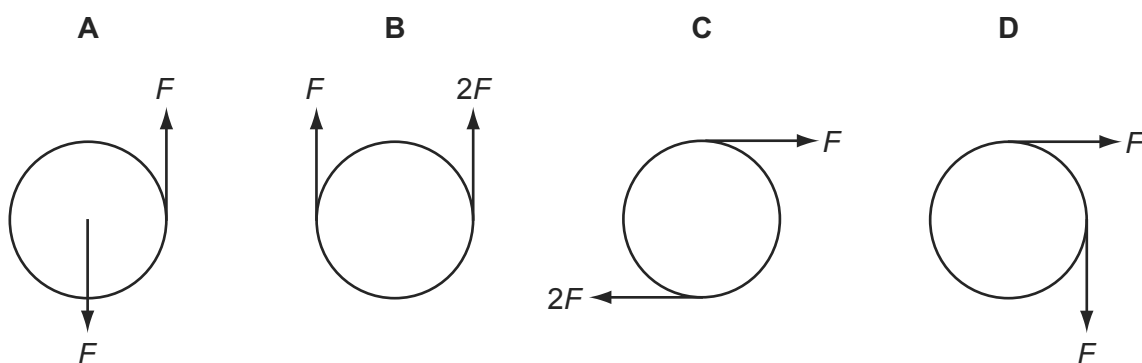

- 51 The diagram represents a sphere under water. P, Q, R, and S are forces acting on the sphere, due to the pressure of the water.

9702/01/M/J/09/Q11

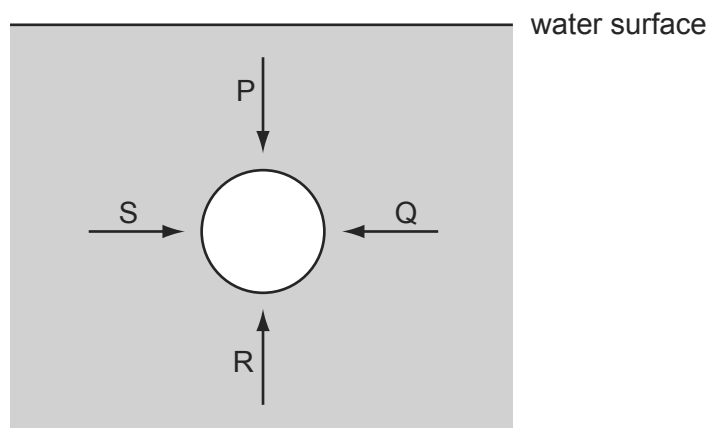

Each force acts perpendicularly to the sphere's surface. P and R act in opposite directions vertically. Q and S act in opposite directions horizontally.

Which information about the magnitudes of the forces is correct?

- A**  $P < R$  ;  $S = Q$   
**B**  $P > R$  ;  $S = Q$   
**C**  $P = R$  ;  $S = Q$   
**D**  $P = R = S = Q$
- 52 A spindle is attached at one end to the centre of a lever 1.20 m long and at its other end to the centre of a disc of radius 0.20 m. A cord is wrapped round the disc, passes over a pulley and is attached to a 900 N weight.

9702/01/M/J/09/Q13

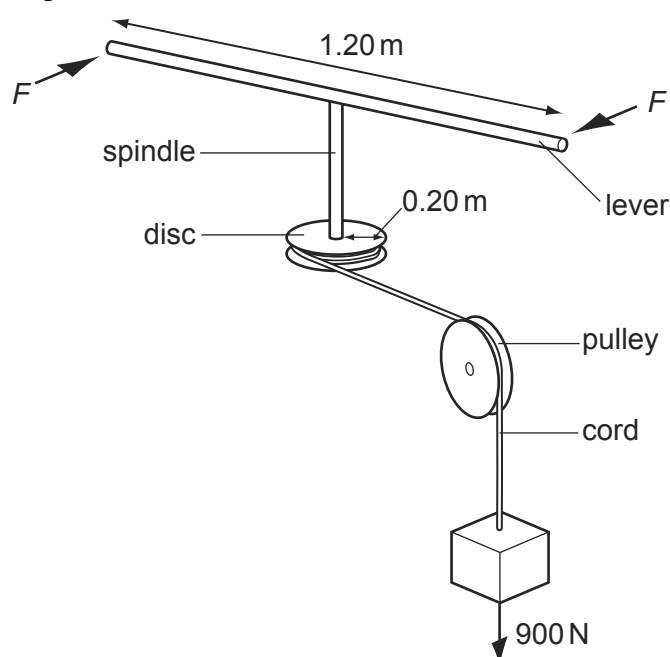

What is the minimum force  $F$ , applied to each end of the lever, that could lift the weight?

- A** 75 N      **B** 150 N      **C** 300 N      **D** 950 N

53 What is the centre of gravity of an object?

- A the geometrical centre of the object
- B the point about which the total torque is zero
- C the point at which the weight of the object may be considered to act
- D the point through which gravity acts

54 The diagrams show two ways of hanging the same picture.

9702/11/O/N/09/Q12

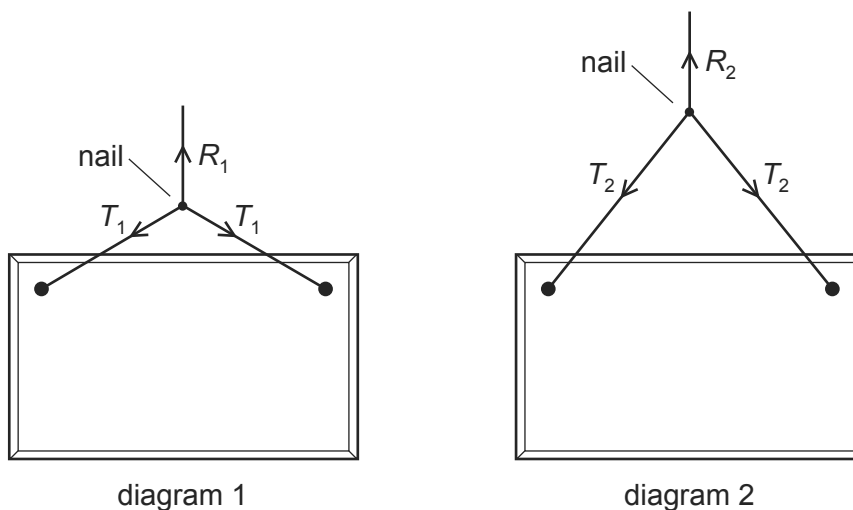

In both cases, a string is attached to the same points on the picture and looped symmetrically over a nail in a wall. The forces shown are those that act on the nail.

In diagram 1, the string loop is shorter than in diagram 2.

Which information about the magnitude of the forces is correct?

- A  $R_1 = R_2$        $T_1 = T_2$
- B  $R_1 = R_2$        $T_1 > T_2$
- C  $R_1 > R_2$        $T_1 < T_2$
- D  $R_1 < R_2$        $T_1 = T_2$

55 An object, immersed in a liquid in a tank, experiences an upthrust.

9702/12/M/J/10/Q13

What is the physical reason for this upthrust?

- A The density of the body differs from that of the liquid.
- B The density of the liquid increases with depth.
- C The pressure in the liquid increases with depth.
- D The value of  $g$  in the liquid increases with depth.

56 What is the centre of gravity of an object?

- A the geometrical centre of the object
- B the point about which the total torque is zero
- C the point at which the weight of the object may be considered to act
- D the point through which gravity acts

57 The diagrams show two ways of hanging the same picture.

9702/12/O/N/09/Q11

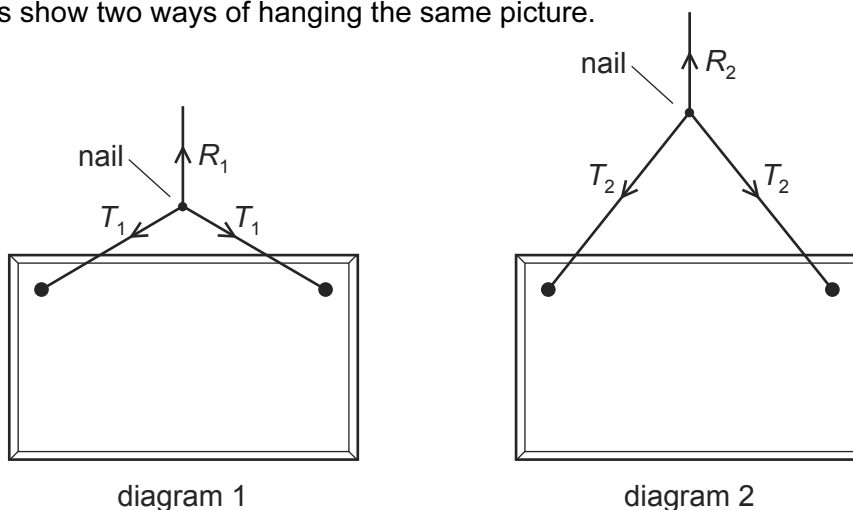

In both cases, a string is attached to the same points on the picture and looped symmetrically over a nail in a wall. The forces shown are those that act on the nail.

In diagram 1, the string loop is shorter than in diagram 2.

Which information about the magnitude of the forces is correct?

- A  $R_1 = R_2$        $T_1 = T_2$
  - B  $R_1 = R_2$        $T_1 > T_2$
  - C  $R_1 > R_2$        $T_1 < T_2$
  - D  $R_1 < R_2$        $T_1 = T_2$
- 58 A brick weighing 20N rests on an inclined plane. The weight of the brick has a component of 10N parallel with the plane. The brick also experiences a frictional force of 4N.

9702/11/M/J/10/Q11

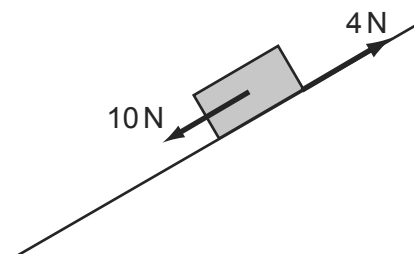

What is the acceleration of the brick down the plane? Assume that the acceleration of free fall  $g$  is equal to  $10 \text{ ms}^{-2}$ .

- A  $0.3 \text{ ms}^{-2}$
- B  $0.8 \text{ ms}^{-2}$
- C  $3.0 \text{ ms}^{-2}$
- D  $8.0 \text{ ms}^{-2}$



- 59 A brick weighing 20 N rests on an inclined plane. The weight of the brick has a component of 10 N parallel with the plane. The brick also experiences a frictional force of 4 N. 9702/12/M/J/10/Q14

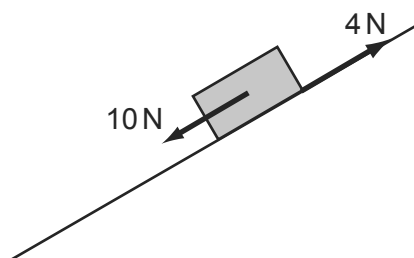

What is the acceleration of the brick down the plane? Assume that the acceleration of free fall  $g$  is equal to  $10 \text{ ms}^{-2}$ .

- A**  $0.3 \text{ ms}^{-2}$       **B**  $0.8 \text{ ms}^{-2}$       **C**  $3.0 \text{ ms}^{-2}$       **D**  $8.0 \text{ ms}^{-2}$
- 60 An object, immersed in a liquid in a tank, experiences an upthrust. 9702/13/M/J/10/Q10

What is the physical reason for this upthrust?

- A** The density of the body differs from that of the liquid.  
**B** The density of the liquid increases with depth.  
**C** The pressure in the liquid increases with depth.  
**D** The value of  $g$  in the liquid increases with depth.
- 61 A rigid L-shaped lever arm is pivoted at point P. 9702/11/O/N/10/Q13

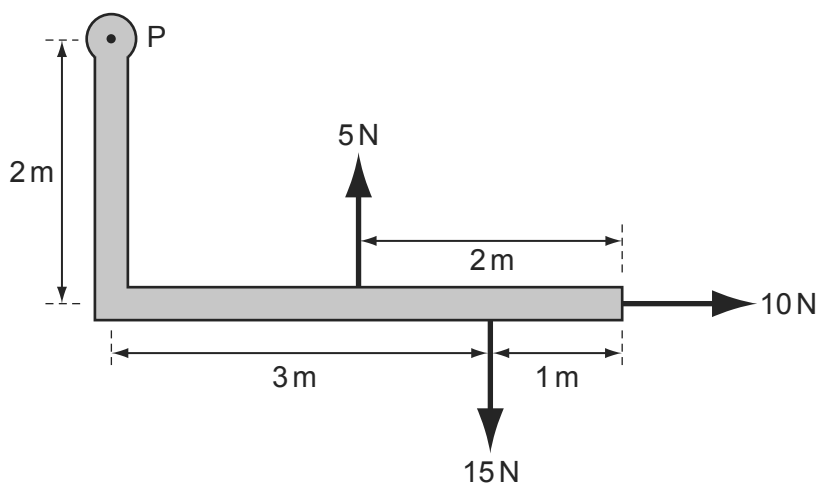

Three forces act on the lever arm, as shown in the diagram.

What is the magnitude of the resultant moment of these forces about point P?

- A** 15 Nm      **B** 20 Nm      **C** 35 Nm      **D** 75 Nm

- 62 Two parallel forces, each of magnitude  $F$ , act on a body as shown.

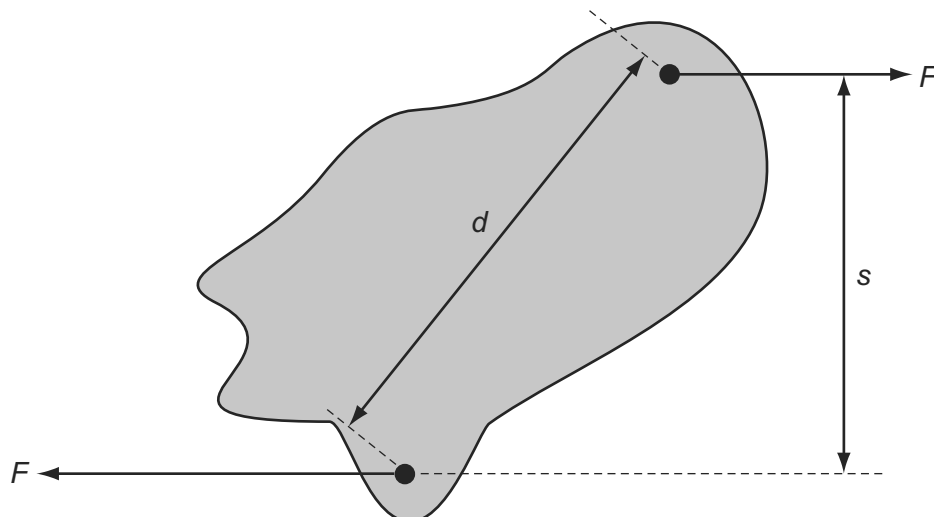

What is the magnitude of the torque on the body produced by these forces?

- A**  $Fd$                       **B**  $Fs$                       **C**  $2Fd$                       **D**  $2Fs$
- 63 A street lamp is fixed to a wall by a metal rod and a cable.

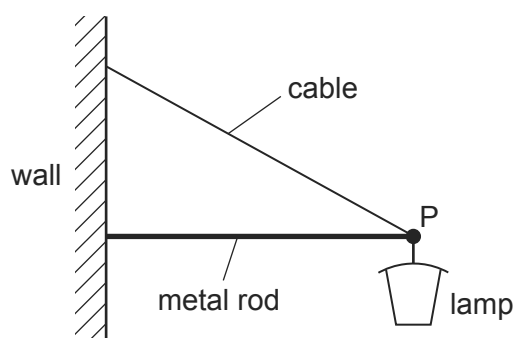

Which vector triangle represents the forces acting at point P?

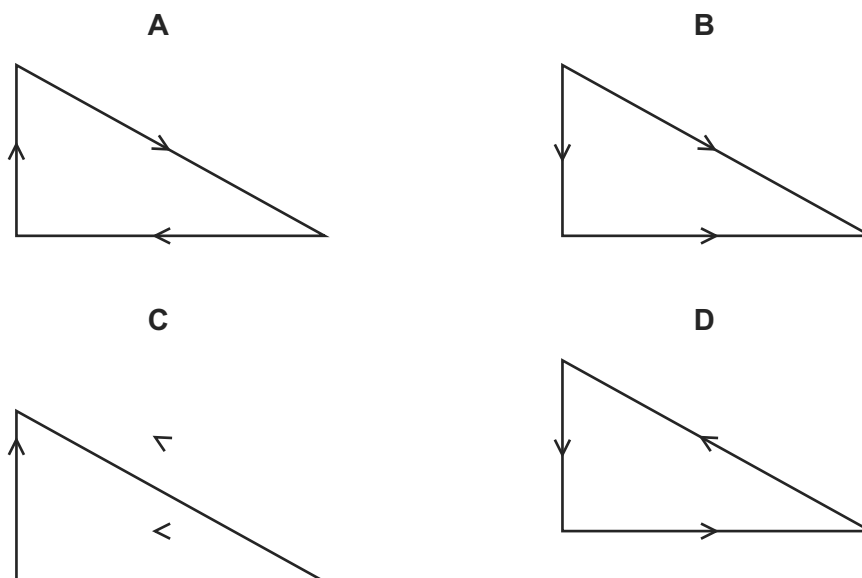

- 64 The diagram shows a rope bridge that a student makes on an adventure training course. The student has a weight  $W$ .

9702/12/O/N/10/Q11

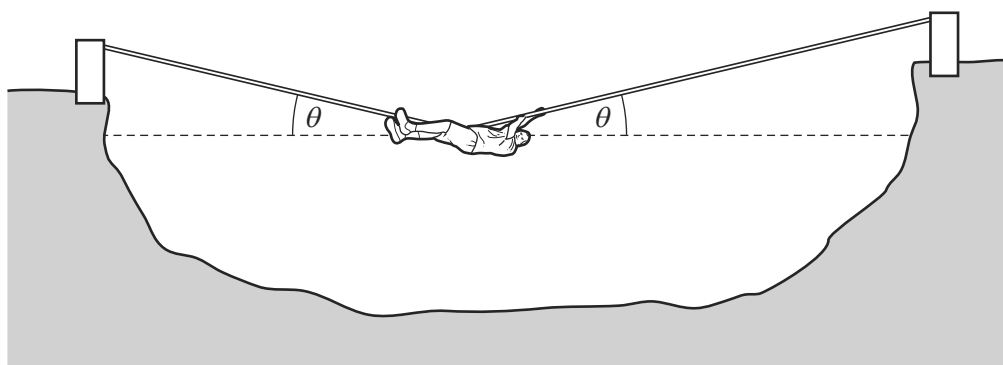

Which formula gives the tension  $T$  in the rope?

- A  $T = \frac{W}{2\cos\theta}$     B  $T = \frac{W}{2\sin\theta}$     C  $T = \frac{W}{\cos\theta}$     D  $T = \frac{W}{\sin\theta}$

- 65 A spanner is used to tighten a nut as shown.

9702/12/O/N/10/Q12

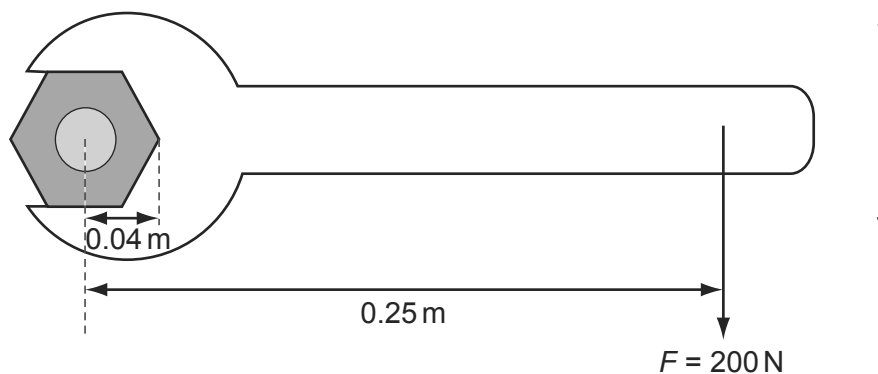

A force  $F$  is applied at right-angles to the spanner at a distance of 0.25 m from the centre of the nut. When the nut is fully tightened, the applied force is 200 N.

What is the resistive torque, in an anticlockwise direction, preventing further tightening?

- A 8 Nm    B 42 Nm    C 50 Nm    D 1250 Nm
- 66 The diagrams all show a pair of equal forces acting on a metre rule.

Which diagram shows forces that provide a couple and zero resultant force?

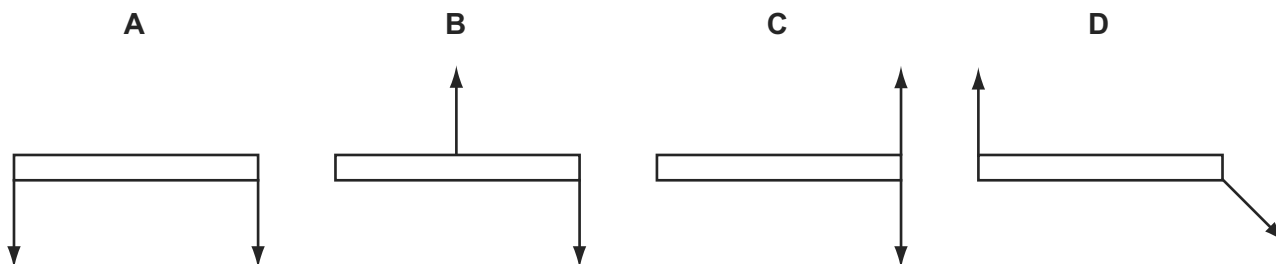

67 A street lamp is fixed to a wall by a metal rod and a cable.

9702/13/O/N/10/Q13

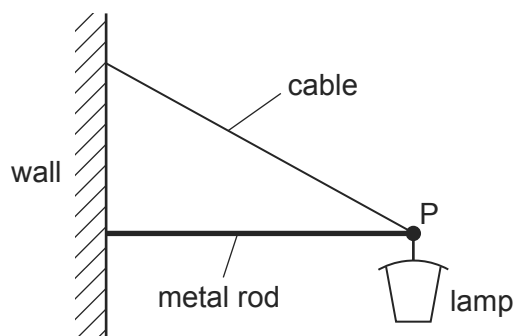

Which vector triangle represents the forces acting at point P?

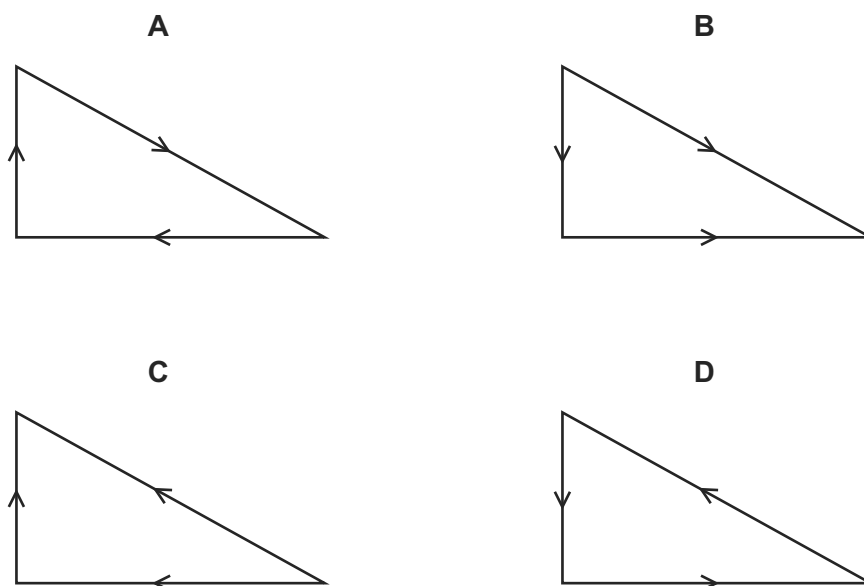

68 The diagram shows four forces applied to a circular object.

9702/11/M/J/11/Q12

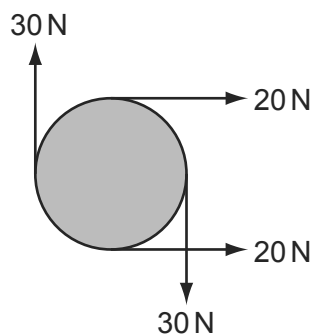

Which row describes the resultant force and resultant torque on the object?

	resultant force	resultant torque
<b>A</b>	zero	zero
<b>B</b>	zero	non-zero
<b>C</b>	non-zero	zero
<b>D</b>	non-zero	non-zero

- 69 A rigid L-shaped lever arm is pivoted at point P.

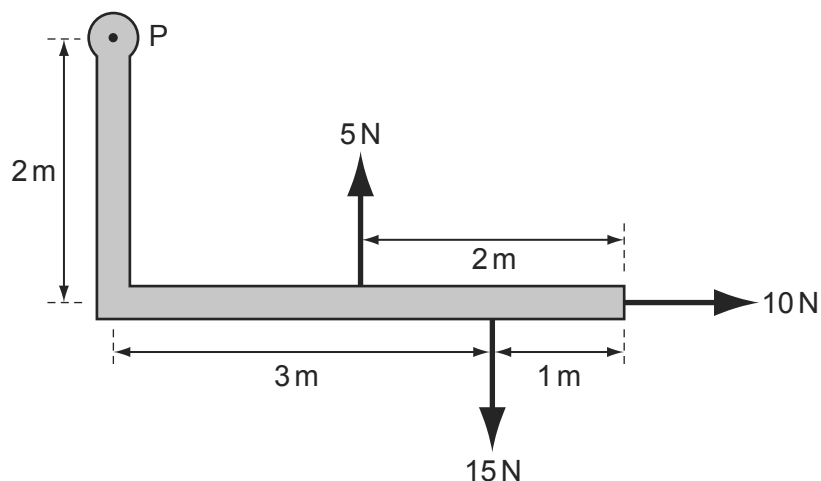

Three forces act on the lever arm, as shown in the diagram.

What is the magnitude of the resultant moment of these forces about point P?

- A** 15 Nm      **B** 20 Nm      **C** 35 Nm      **D** 75 Nm
- 70 A cable car of weight  $W$  hangs in equilibrium from its cable at point P.

The cable has tensions  $T_1$  and  $T_2$  as shown.

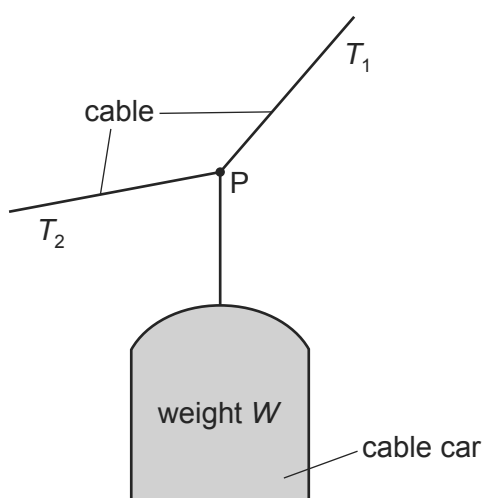

Which diagram correctly represents the forces acting at point P?

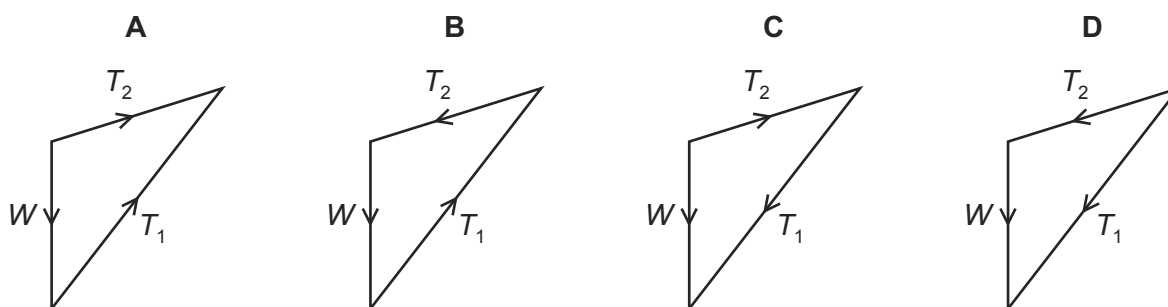

- 71 A uniform rod  $XY$  of weight  $10.0\text{ N}$  is freely hinged to a wall at  $X$ . It is held horizontal by a force  $F$  acting from  $Y$  at an angle of  $30^\circ$  to the horizontal, as shown. 9702/12/M/J/11/Q16

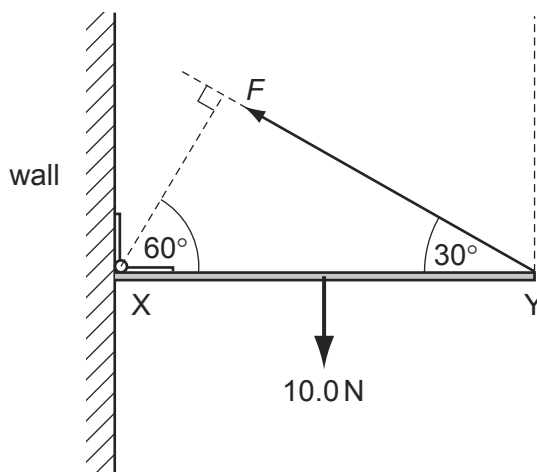

What is the value of  $F$ ?

- A**  $5.0\text{ N}$       **B**  $8.7\text{ N}$       **C**  $10.0\text{ N}$       **D**  $20.0\text{ N}$
- 72 A ladder rests in equilibrium on rough ground against a rough wall. 9702/11/O/N/11/Q13

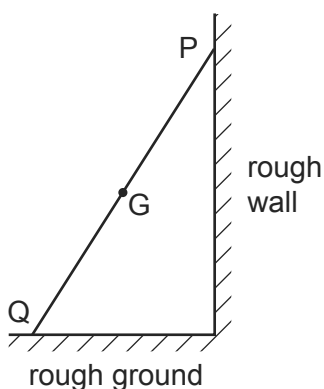

Its weight  $W$  acts through the centre of gravity  $G$ . Forces also act on the ladder at  $P$  and at  $Q$ . These forces are  $P$  and  $Q$  respectively.

Which vector triangle represents the forces on the ladder?

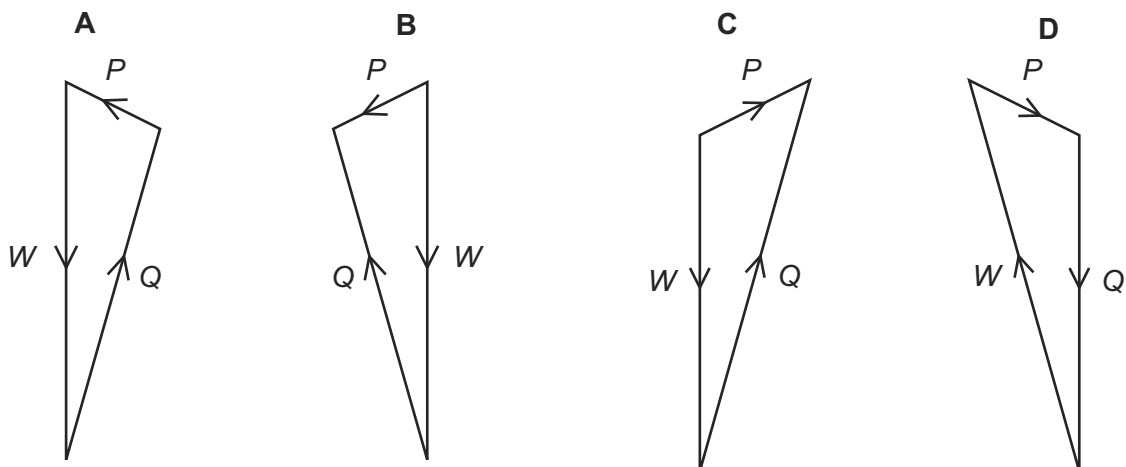

- 73 A uniform metre rule of mass 100 g is supported by a pivot at the 40 cm mark and a string at the 100 cm mark. The string passes round a frictionless pulley and carries a mass of 20 g as shown in the diagram.

9702/11/M/J/11/Q13

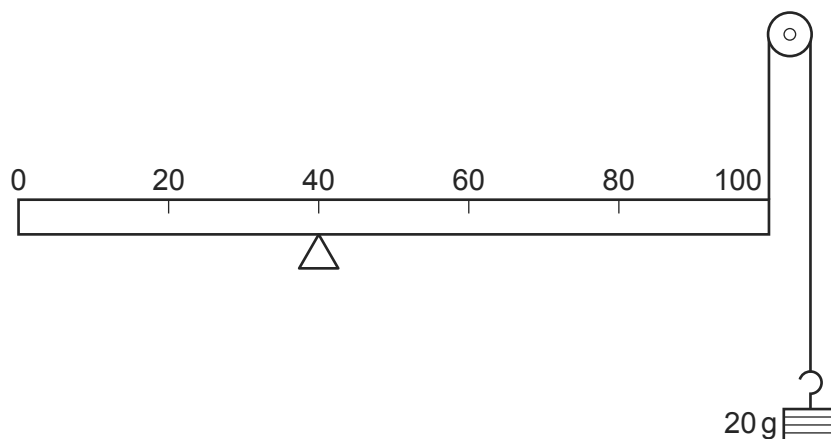

At which mark on the rule must a 50 g mass be suspended so that the rule balances?

- A** 4 cm      **B** 36 cm      **C** 44 cm      **D** 64 cm
- 74 A cable car of weight  $W$  hangs in equilibrium from its cable at point P.

9702/13/M/J/11/Q13

The cable has tensions  $T_1$  and  $T_2$  as shown.

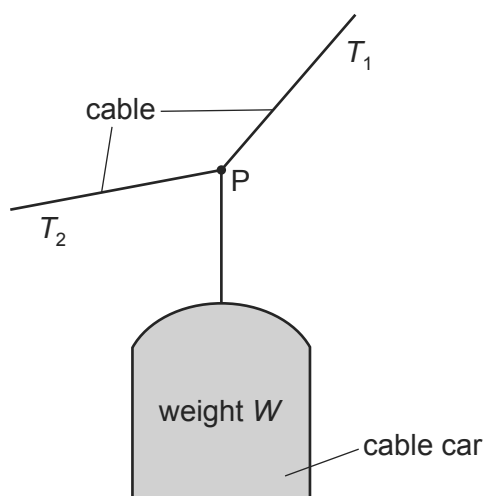

Which diagram correctly represents the forces acting at point P?

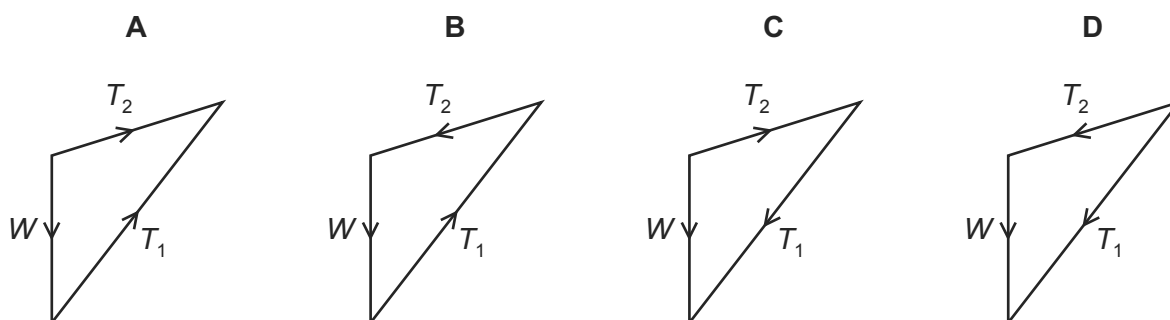

- 75 The diagram shows two fixed pins, Y and Z. A length of elastic is stretched between Y and Z and around pin X, which is attached to a trolley. 9702/12/M/J/11/Q17

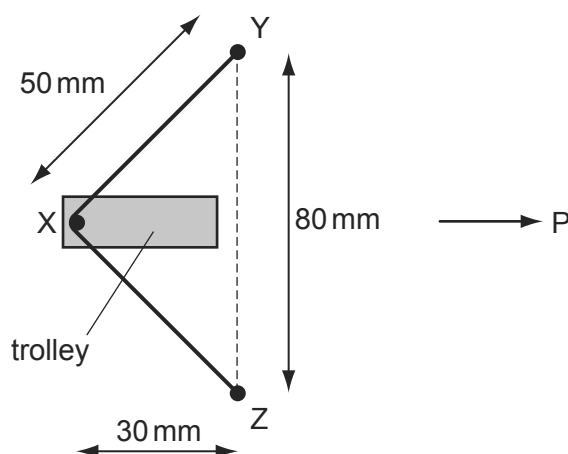

X is at the centre of the elastic and the trolley is to be propelled in the direction P at right angles to YZ. The tension in the elastic is 4 N.

What is the force accelerating the trolley in the direction P when the trolley is released?

- A** 2.4 N      **B** 3.2 N      **C** 4.8 N      **D** 6.4 N
- 76 The diagram shows four forces applied to a circular object. 9702/13/M/J/11/Q11

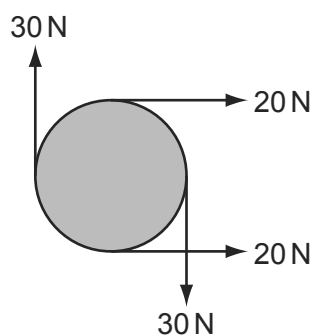

Which row describes the resultant force and resultant torque on the object?

	resultant force	resultant torque
<b>A</b>	zero	zero
<b>B</b>	zero	non-zero
<b>C</b>	non-zero	zero
<b>D</b>	non-zero	non-zero



- 77 A uniform metre rule of mass 100 g is supported by a pivot at the 40 cm mark and a string at the 100 cm mark. The string passes round a frictionless pulley and carries a mass of 20 g as shown in the diagram.

9702/13/M/J/11/Q12

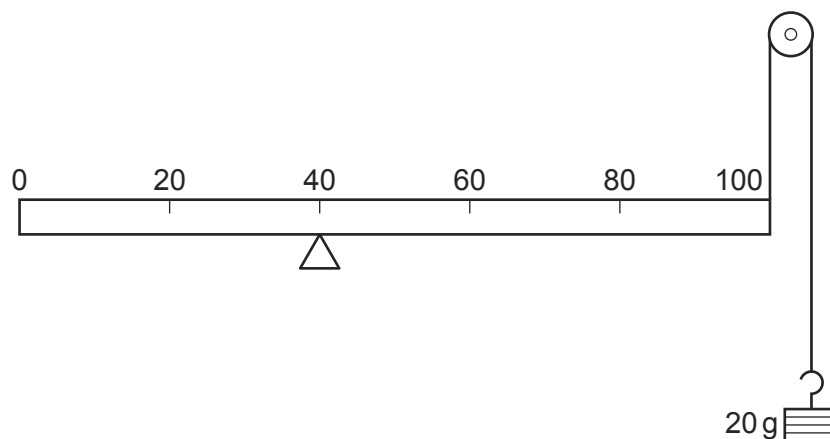

At which mark on the rule must a 50 g mass be suspended so that the rule balances?

- A** 4 cm      **B** 36 cm      **C** 44 cm      **D** 64 cm
- 78 Two parallel forces, each of magnitude  $F$ , act on a body as shown.

9702/13/O/N/10/Q15

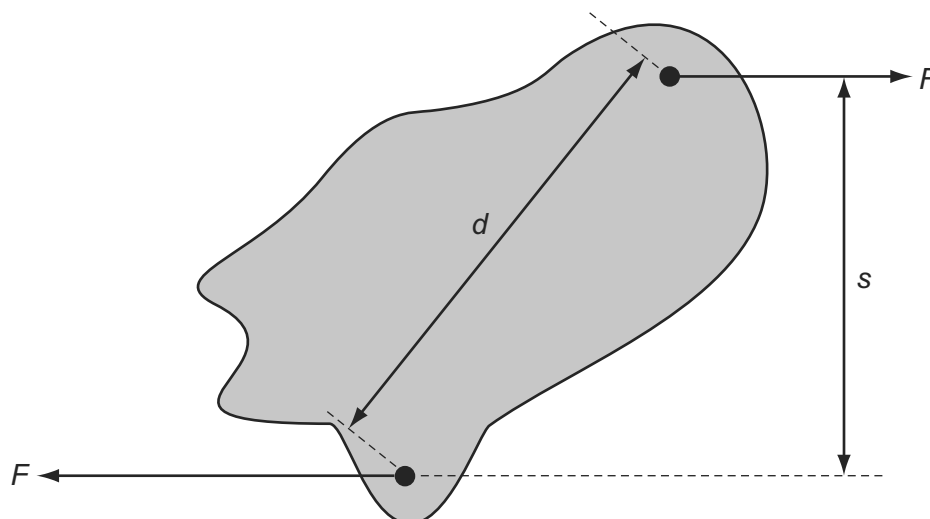

What is the magnitude of the torque on the body produced by these forces?

- A**  $Fd$       **B**  $Fs$       **C**  $2Fd$       **D**  $2Fs$
- 79 Two co-planar forces act on the rim of a wheel. The forces are equal in magnitude.

9702/12/O/N/11/Q13

Which arrangement of forces provides only a couple?

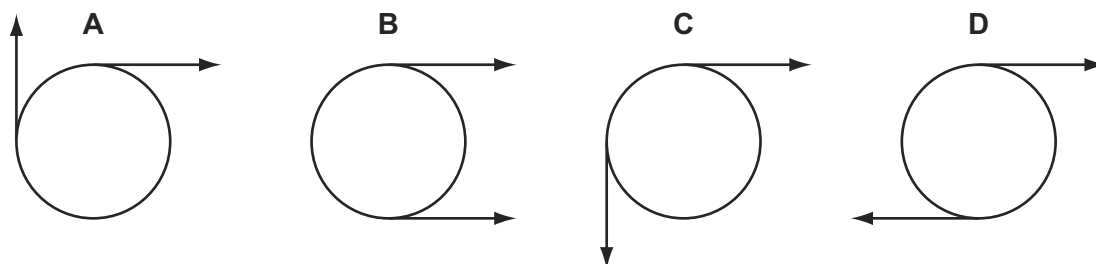

- 80 A ruler of length 0.30 m is pivoted at its centre. Equal and opposite forces of magnitude 2.0 N are applied to the ends of the ruler, creating a couple as shown. 9702/11/O/N/11/Q14

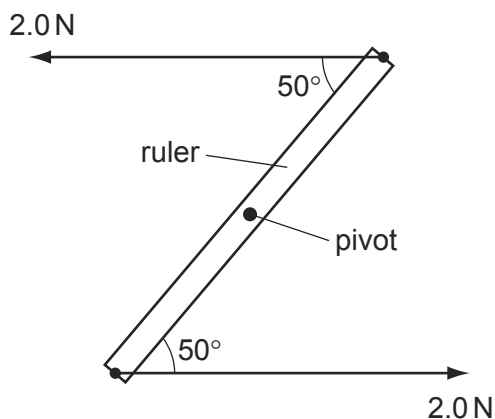

What is the magnitude of the torque of the couple on the ruler when it is in the position shown?

- A 0.23 N m      B 0.39 N m      C 0.46 N m      D 0.60 N m
- 81 The diagram shows a child's balancing game. 9702/11/O/N/11/Q15

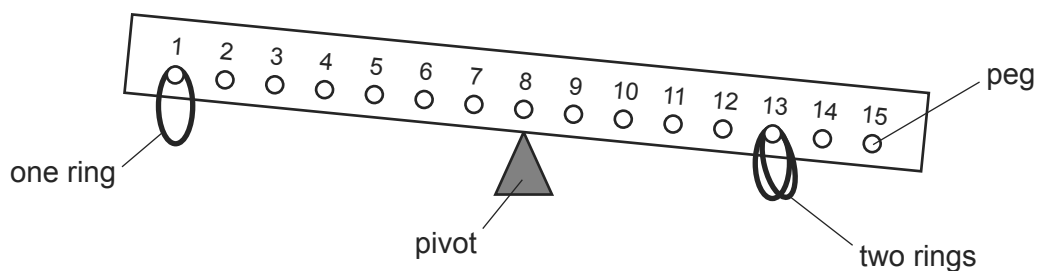

The wooden rod is uniform and all the rings are of equal mass. Two rings are hung on peg 13 and one on peg 1.

On which hook must a fourth ring be hung in order to balance the rod?

- A 2      B 3      C 5      D 6
- 82 A trailer of weight 30 kN is hitched to a cab at X, as shown in the diagram. 9702/12/O/N/11/Q14

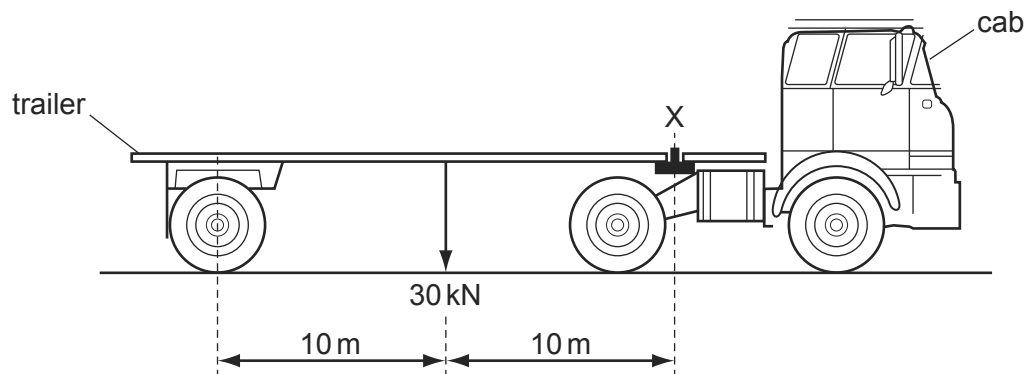

What is the upward force exerted by the cab on the trailer at X?

- A 3 kN      B 15 kN      C 30 kN      D 60 kN

- 83 Two possible displacements of an object are represented by the vectors P and Q.

9702/12/O/N/11/Q12

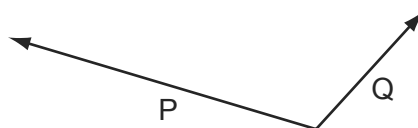

Which vector best represents the resultant displacement ( $P - Q$ ) of the object?

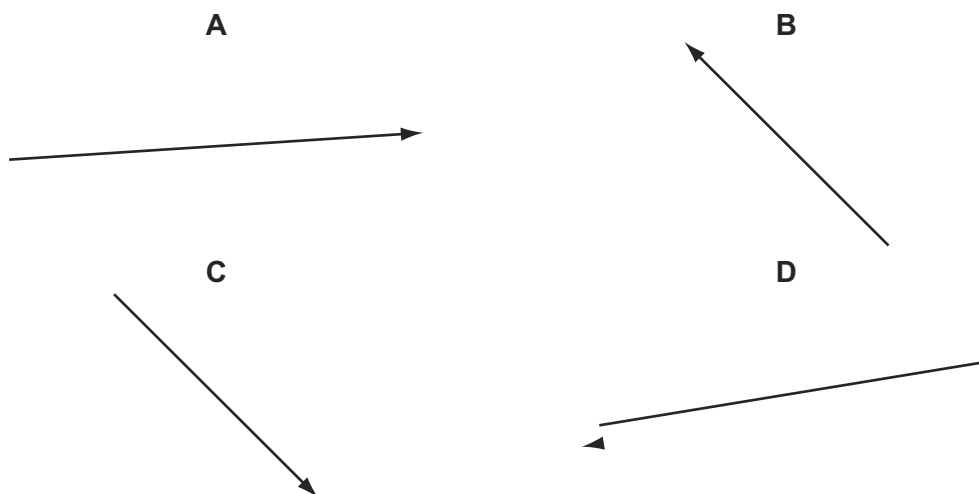

- 84 The diagram shows a child's balancing game.

9702/13/O/N/11/Q13

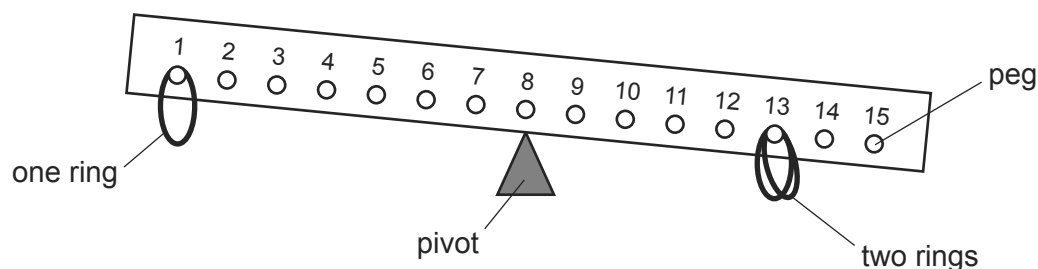

The wooden rod is uniform and all the rings are of equal mass. Two rings are hung on peg 13 and one on peg 1.

On which hook must a fourth ring be hung in order to balance the rod?

- A** 2                      **B** 3                      **C** 5                      **D** 6
- 85 A cylindrical block of wood has cross-sectional area  $A$  and weight  $W$ . It is totally immersed in water with its axis vertical. The block experiences pressures  $p_t$  and  $p_b$  at its top and bottom surfaces respectively.

9702/11/M/J/12/Q13

Which expression is equal to the upthrust on the block?

- A**  $(p_b - p_t)A + W$   
**B**  $(p_b - p_t)$   
**C**  $(p_b - p_t)A$   
**D**  $(p_b - p_t)A - W$

86 A ladder rests in equilibrium on rough ground against a rough wall.

9702/13/O/N/11/Q14

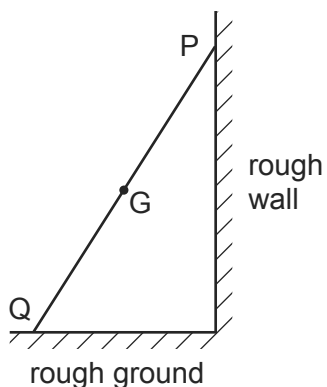

Its weight  $W$  acts through the centre of gravity  $G$ . Forces also act on the ladder at  $P$  and at  $Q$ . These forces are  $P$  and  $Q$  respectively.

Which vector triangle represents the forces on the ladder?

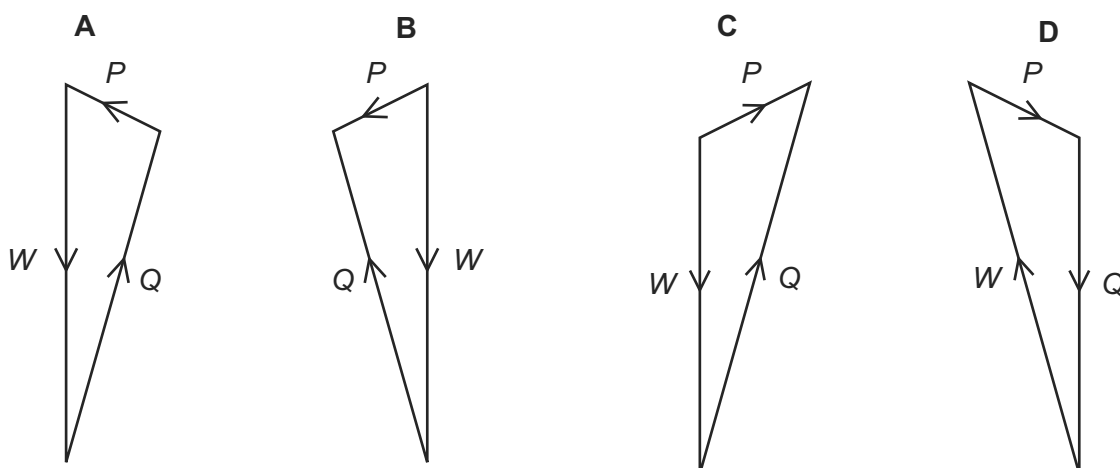

87 A ruler of length 0.30 m is pivoted at its centre. Equal and opposite forces of magnitude 2.0 N are applied to the ends of the ruler, creating a couple as shown.

9702/13/O/N/11/Q15

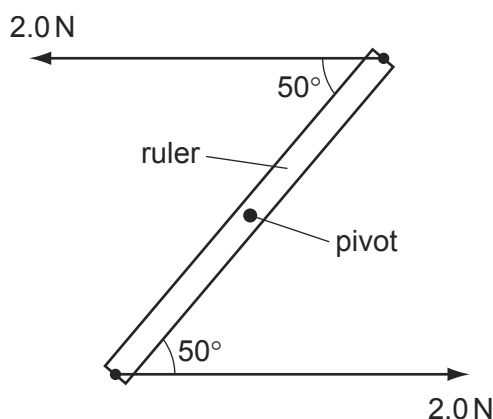

What is the magnitude of the torque of the couple on the ruler when it is in the position shown?

- A** 0.23 N m      **B** 0.39 N m      **C** 0.46 N m      **D** 0.60 N m

- 88 The diagram shows a barrel suspended from a frictionless pulley on a building. The rope supporting the barrel goes over the pulley and is secured to a stake at the bottom of the building.

9702/11/M/J/12/Q12

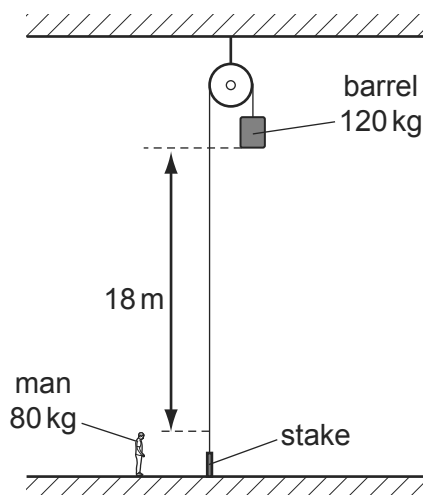

A man stands close to the stake. The bottom of the barrel is 18 m above the man's head. The mass of the barrel is 120 kg and the mass of the man is 80 kg.

The man keeps hold of the rope after untying it from the stake and is lifted upwards as the barrel falls.

What is the man's upward speed when his head is level with the bottom of the barrel? (Use  $g = 10 \text{ m s}^{-2}$ .)

- A**  $6 \text{ m s}^{-1}$       **B**  $8 \text{ m s}^{-1}$       **C**  $13 \text{ m s}^{-1}$       **D**  $19 \text{ m s}^{-1}$
- 89 A car of mass  $m$  travels at constant speed up a slope at an angle  $\theta$  to the horizontal, as shown in the diagram. Air resistance and friction provide a resistive force  $F$ .

9702/11/M/J/12/Q14

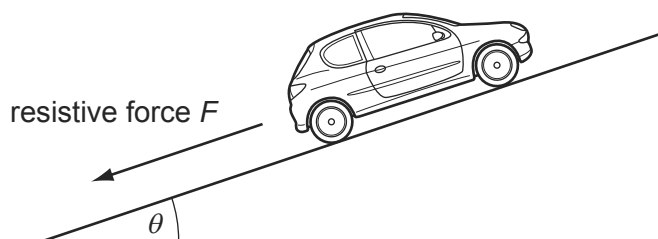

What force is needed to propel the car at this constant speed?

- A**  $mg \cos \theta$   
**B**  $mg \sin \theta$   
**C**  $mg \cos \theta + F$   
**D**  $mg \sin \theta + F$

90 The diagram shows a crane supporting a load  $L$ .

9702/11/M/J/12/Q15

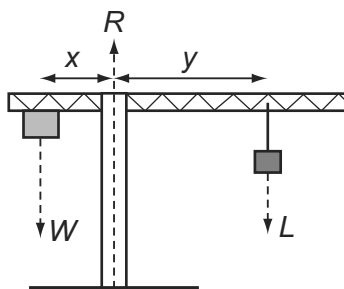

A mass provides a balancing load  $W$ . The position of the load is such that the system is perfectly balanced with  $Wx = Ly$ . The ground provides a reaction force  $R$ . The distance  $x$  does not change.

If the load is moved further out so that the distance  $y$  increases and the crane does not topple, which statement is correct?

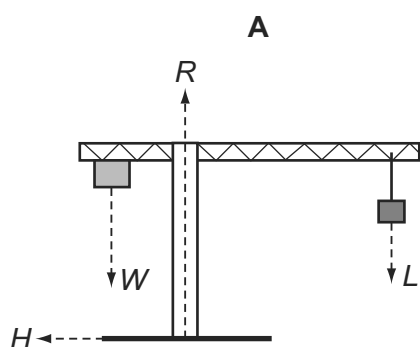

A horizontal force  $H$  acts on the base of the support column towards the left.

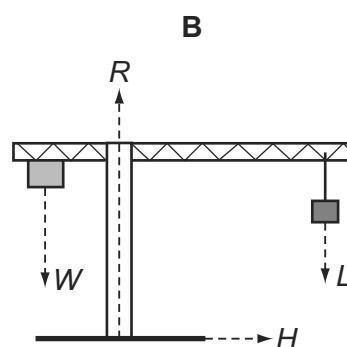

A horizontal force  $H$  acts on the base of the support column towards the right.

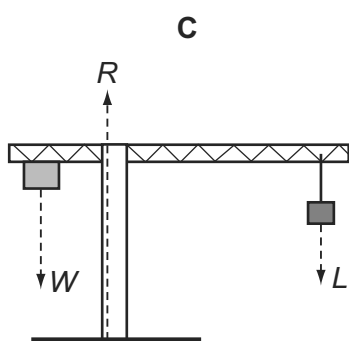

The reaction force  $R$  moves to the left.

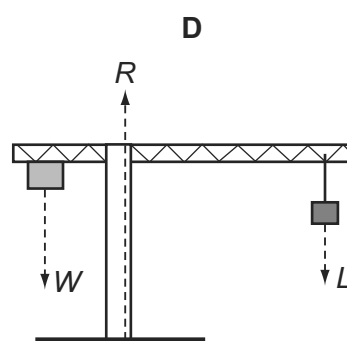

The reaction force  $R$  moves to the right.

- 91 A box of mass  $8.0\text{ kg}$  rests on a horizontal, rough surface. A string attached to the box passes over a smooth pulley and supports a  $2.0\text{ kg}$  mass at its other end.

9702/12/M/J/12/Q13

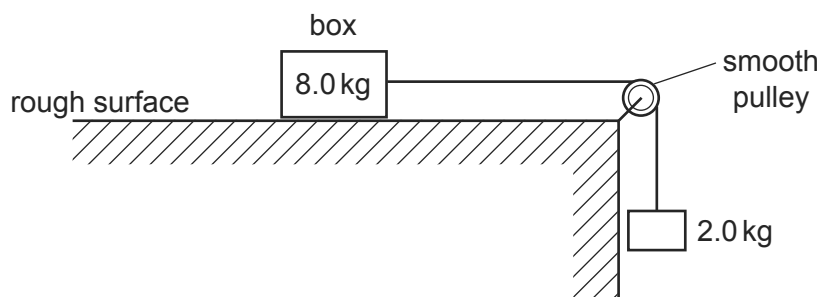

When the box is released, a frictional force of  $6.0\text{ N}$  acts on it.

What is the acceleration of the box?

- A**  $1.4\text{ ms}^{-2}$       **B**  $1.7\text{ ms}^{-2}$       **C**  $2.0\text{ ms}^{-2}$       **D**  $2.5\text{ ms}^{-2}$
- 92 A ladder is positioned on icy (frictionless) ground and is leant against a rough wall. At the instant of release it begins to slide.

9702/12/M/J/12/Q14

Which diagram correctly shows the directions of the forces  $P$ ,  $W$  and  $R$  acting on the ladder as it begins to slide?

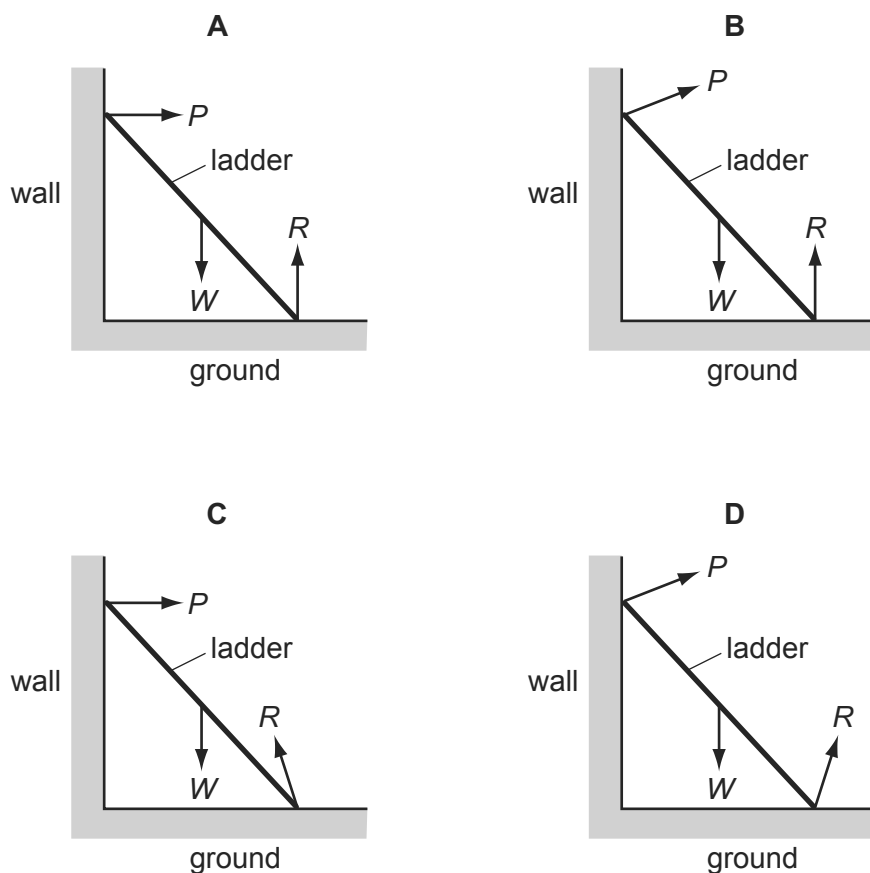

- 93 The diagram shows a solid cube with weight  $W$  and sides of length  $L$ . It is supported by a frictionless spindle that passes through the centres of two opposite vertical faces. One of these faces is shaded.

9702/12/M/J/12/Q15

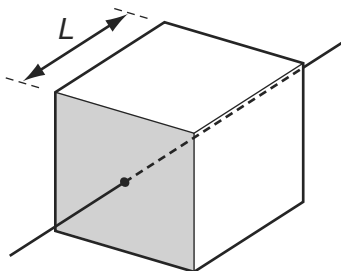

The spindle is now removed and replaced at a distance  $\frac{L}{4}$  to the right of its original position.

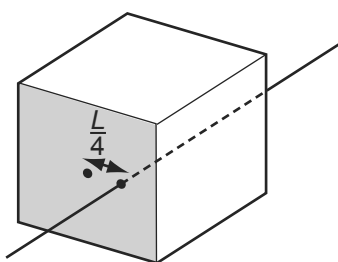

When viewing the shaded face, what is the torque of the couple that will now be needed to stop the cube from toppling?

- A  $\frac{WL}{2}$  anticlockwise
- B  $\frac{WL}{2}$  clockwise
- C  $\frac{WL}{4}$  anticlockwise
- D  $\frac{WL}{4}$  clockwise
- 94 Initially, four identical uniform blocks, each of mass  $m$  and thickness  $h$ , are spread on a table.

9702/12/M/J/12/Q17



How much work is done on the blocks in stacking them on top of one another?

- A  $3mgh$       B  $6mgh$       C  $8mgh$       D  $10mgh$



95 A sphere is released from rest in a viscous fluid.

9702/12/M/J/12/Q16

Which graph represents the variation with time  $t$  of the acceleration  $a$  of the sphere?

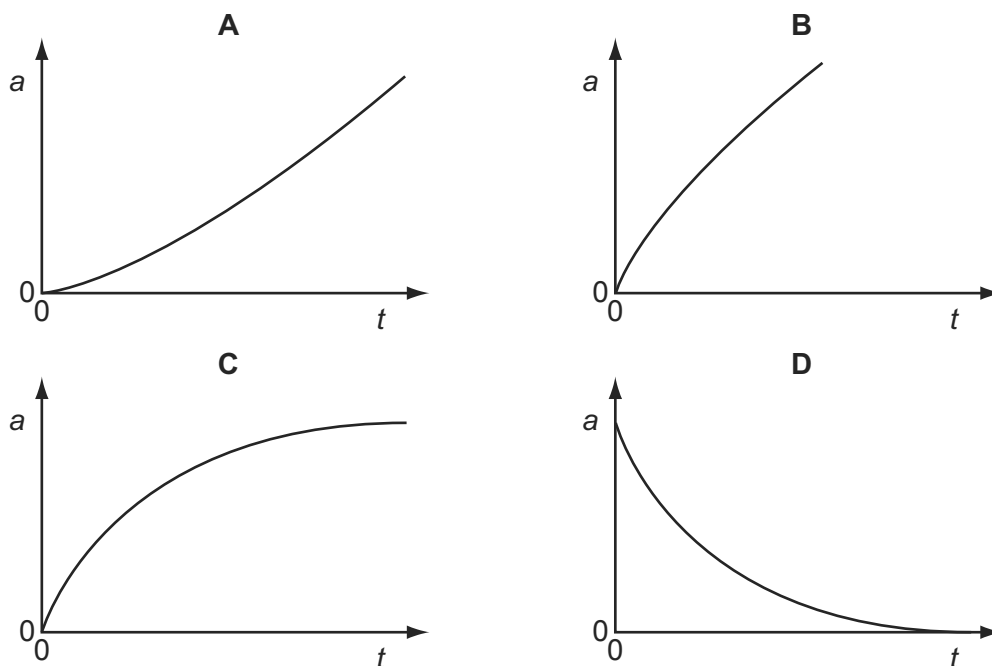

96 Each option gives a correct word equation involving force.

9702/13/M/J/12/Q11

Which option gives the definition of force?

- A** force = energy divided by displacement
- B** force = mass  $\times$  acceleration
- C** force = pressure  $\times$  area
- D** force = rate of change of momentum

97 Two similar spheres, each of mass  $m$  and travelling with speed  $v$ , are moving towards each other.

9702/13/M/J/12/Q12

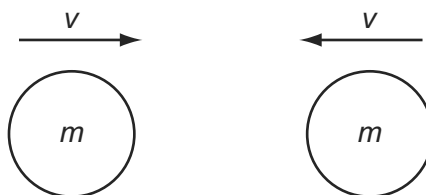

The spheres have a head-on elastic collision.

Which statement is correct?

- A** The spheres stick together on impact.
- B** The total kinetic energy after impact is  $mv^2$ .
- C** The total kinetic energy before impact is zero.
- D** The total momentum before impact is  $2mv$ .

98 The diagram shows a crane supporting a load  $L$ .

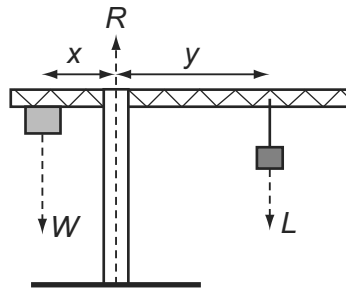

A mass provides a balancing load  $W$ . The position of the load is such that the system is perfectly balanced with  $Wx = Ly$ . The ground provides a reaction force  $R$ . The distance  $x$  does not change.

If the load is moved further out so that the distance  $y$  increases and the crane does not topple, which statement is correct?

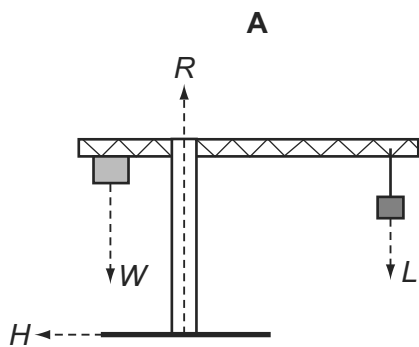

A horizontal force  $H$  acts on the base of the support column towards the left.

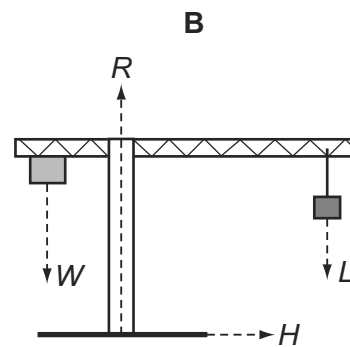

A horizontal force  $H$  acts on the base of the support column towards the right.

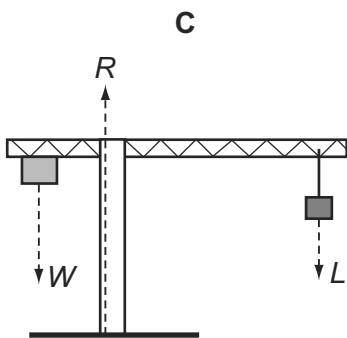

The reaction force  $R$  moves to the left.

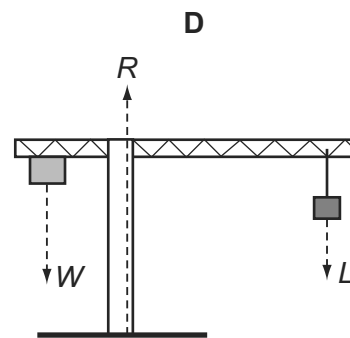

The reaction force  $R$  moves to the right.

- 99 A cylindrical block of wood has cross-sectional area  $A$  and weight  $W$ . It is totally immersed in water with its axis vertical. The block experiences pressures  $p_t$  and  $p_b$  at its top and bottom surfaces respectively.

9702/13/M/J/12/Q14

Which expression is equal to the upthrust on the block?

- A**  $(p_b - p_t)A + W$   
**B**  $(p_b - p_t)$   
**C**  $(p_b - p_t)A$   
**D**  $(p_b - p_t)A - W$

- 100 A car of mass  $m$  travels at constant speed up a slope at an angle  $\theta$  to the horizontal, as shown in the diagram. Air resistance and friction provide a resistive force  $F$ .

9702/13/M/J/12/Q15

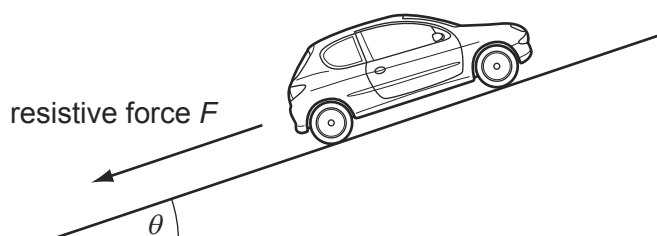

What force is needed to propel the car at this constant speed?

- A**  $mg \cos \theta$   
**B**  $mg \sin \theta$   
**C**  $mg \cos \theta + F$   
**D**  $mg \sin \theta + F$
- 101 A lorry of mass 20 000 kg has a constant resultant force  $F$  acting on it.

9702/12/O/N/12/Q15

It accelerates from  $6.0 \text{ m s}^{-1}$  to  $30.0 \text{ m s}^{-1}$  in a time of 300 s.

What is the change in momentum of the lorry and the value of  $F$ ?

	change in momentum / N s	force $F$ / N
<b>A</b>	48 000	160
<b>B</b>	480 000	1600
<b>C</b>	600 000	2000
<b>D</b>	600 000	20 000

102 A rigid uniform beam is pivoted horizontally at its midpoint.

9702/12/O/N/12/Q17

Different vertical forces are applied to different positions on the beam.

In which diagram is the beam in equilibrium?

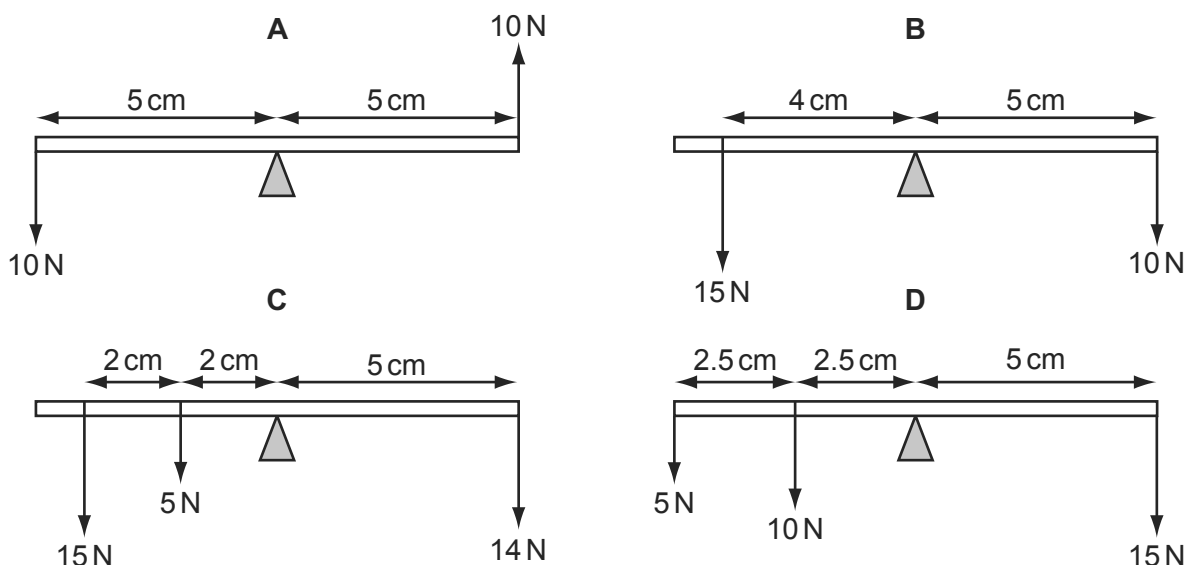

103 A picture on a wall is supported by a wire looped over a nail.

9702/12/O/N/12/Q18

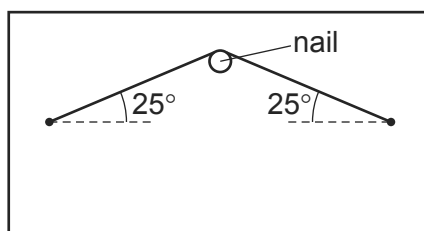

The mass of the picture is 4.2 kg.

What is the tension in the supporting wire?

- A** 5.0 N      **B** 23 N      **C** 49 N      **D** 97 N

104 A stationary body floats in water.

9702/12/O/N/12/Q16

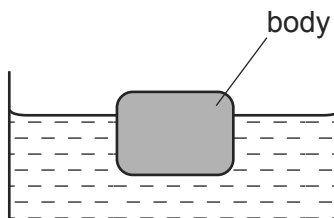

Which statement about the forces acting on the body is correct?

- A** The gravitational force is equal to the viscous force.  
**B** The gravitational force is greater than the upthrust.  
**C** The upthrust is zero.  
**D** The viscous force is zero.

- 105 The diagram shows an experiment to measure the force exerted on a ball by a horizontal air flow.

9702/11/O/N/12/Q15

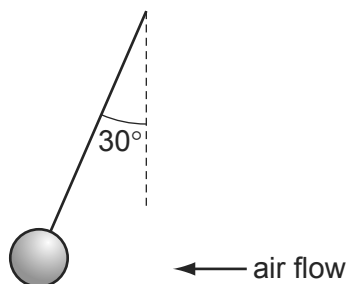

The ball is suspended by a light string and weighs 0.15 N.

The deflection of the string from vertical is  $30^\circ$ .

What is the force on the ball from the air flow?

- A** 0.075 N      **B** 0.087 N      **C** 0.26 N      **D** 0.30 N
- 106 A student balances a 30 cm ruler on a fulcrum set at the 15 cm mark. She then places a 50 g mass on the 23 cm mark and a 20 g mass on the 11 cm mark, as shown.

9702/11/O/N/12/Q16



Which mass should she place on the 7 cm mark to restore the balance?

- A** 30 g      **B** 40 g      **C** 47 g      **D** 133 g
- 107 A sledge slides down a slope at a constant velocity. The three forces that act on the sledge are the normal contact force  $C$ , the weight  $W$  and a constant frictional force  $F$ .

9702/11/O/N/12/Q17

Which diagram represents these forces acting on the sledge?

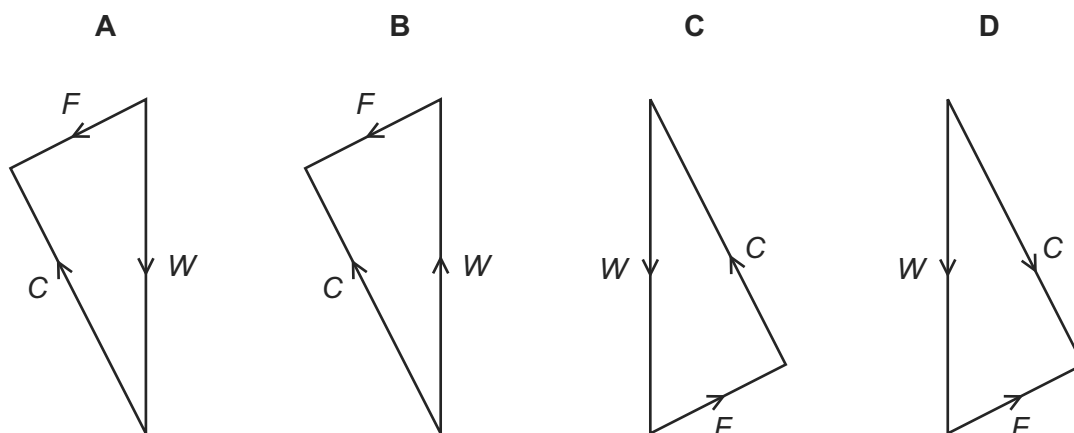

108 A hailstone, initially stationary at the base of a cloud, falls vertically towards the Earth. The diagram shows the magnitudes and directions of the forces acting on the hailstone as it starts to drop.

9702/13/O/N/12/Q15

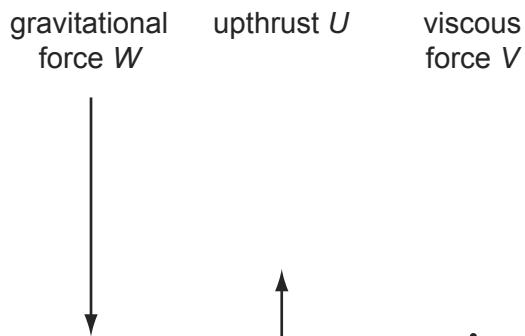

Which diagram shows the magnitudes and directions of these forces when the hailstone attains a terminal (constant) speed in the air (of uniform density)?

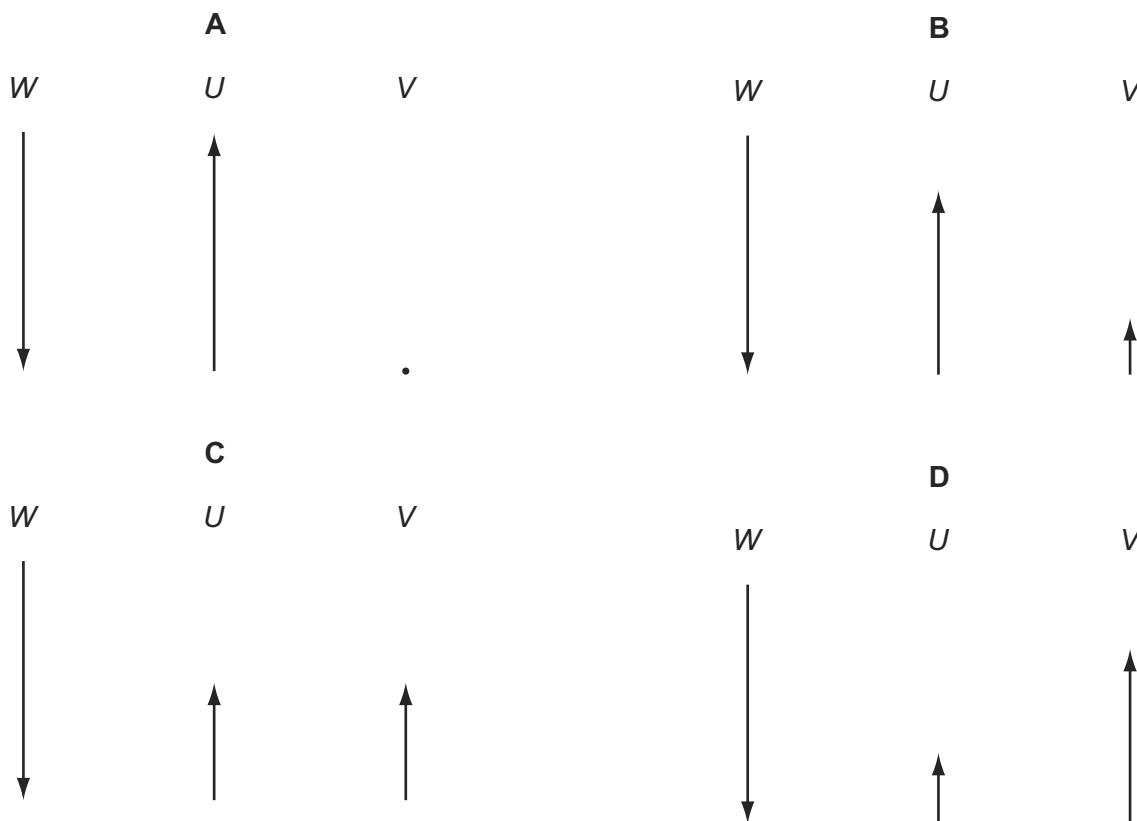

109 A car travelling with speed  $28 \text{ m s}^{-1}$  leaves a motorway on an exit road. The end of the exit road is 22 m higher than the motorway.

9702/13/O/N/12/Q18

If only the force of gravity is considered, what will be the speed of the car at the end of the exit road?

- A**  $7.3 \text{ m s}^{-1}$       **B**  $19 \text{ m s}^{-1}$       **C**  $21 \text{ m s}^{-1}$       **D**  $24 \text{ m s}^{-1}$

110 Four beams of the same length each have three forces acting on them.

9702/13/O/N/12/Q16

Which beam has both zero resultant force and zero resultant torque acting?

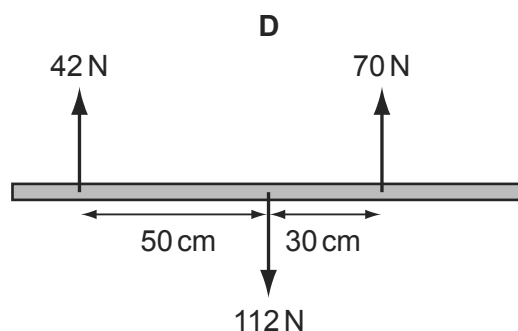
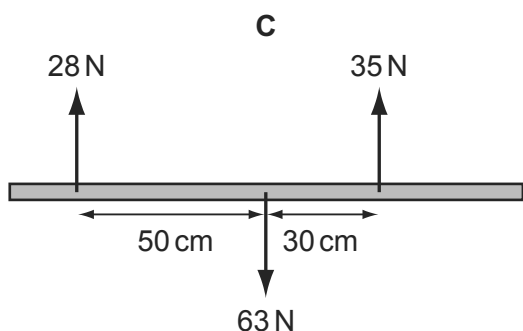
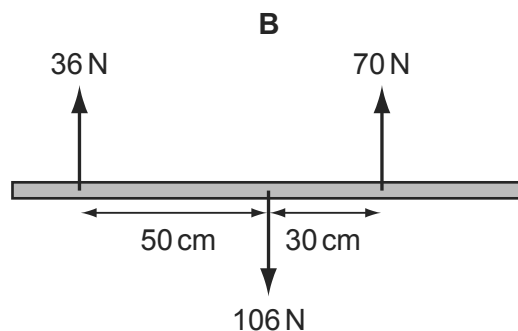
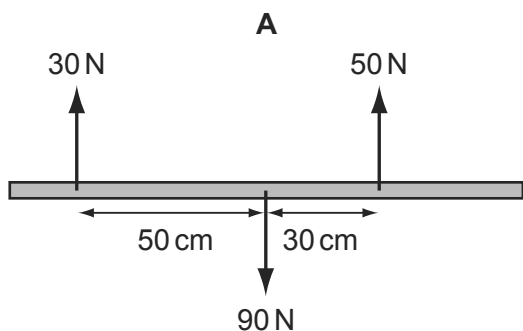

111 The diagrams show the forces acting on different bodies.

9702/13/O/N/12/Q17

Which body **cannot** be in equilibrium?

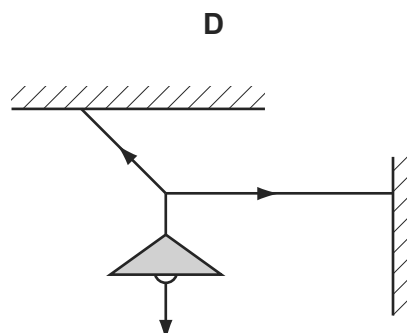
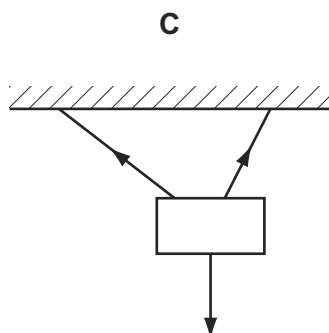
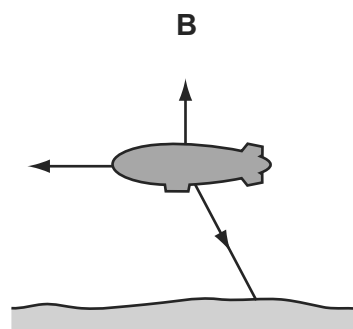
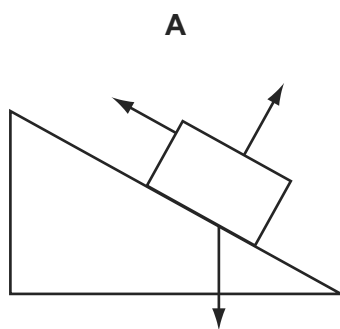

- 112 A car of mass 750 kg has a horizontal driving force of 2.0 kN acting on it. It has a forward horizontal acceleration of  $2.0 \text{ m s}^{-2}$ . 9702/11/M/J/13/Q12

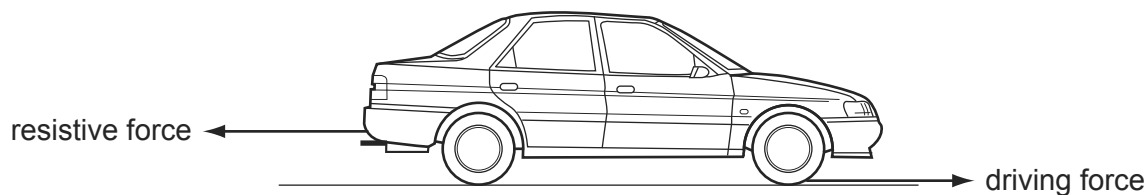

What is the resistive force acting horizontally?

- A** 0.50 kN      **B** 1.5 kN      **C** 2.0 kN      **D** 3.5 kN
- 113 The diagram represents a sphere under water. P, Q, R and S are forces acting on the sphere, due to the pressure of the water. 9702/11/M/J/13/Q15

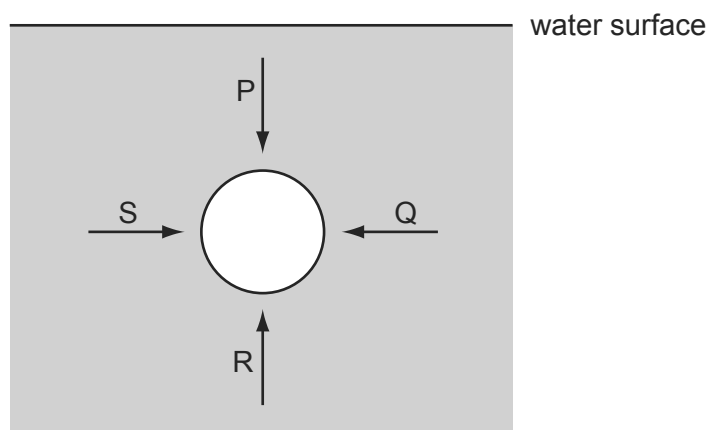

Each force acts perpendicularly to the sphere's surface. P and R act in opposite directions vertically. Q and S act in opposite directions horizontally.

Which information about the magnitudes of the forces is correct?

- A**  $P < R$  and  $S = Q$   
**B**  $P > R$  and  $S = Q$   
**C**  $P = R$  and  $S = Q$  and  $P \neq S$   
**D**  $P = R$  and  $S = Q$  and  $P = S$



- 114 A small water droplet of mass  $3.0\ \mu\text{g}$  carries a charge of  $-6.0 \times 10^{-11}\ \text{C}$ . The droplet is situated in the Earth's gravitational field between two horizontal metal plates. The potential of the upper plate is  $+500\ \text{V}$  and the potential of the lower plate is  $-500\ \text{V}$ .

9702/11/M/J/13/Q13

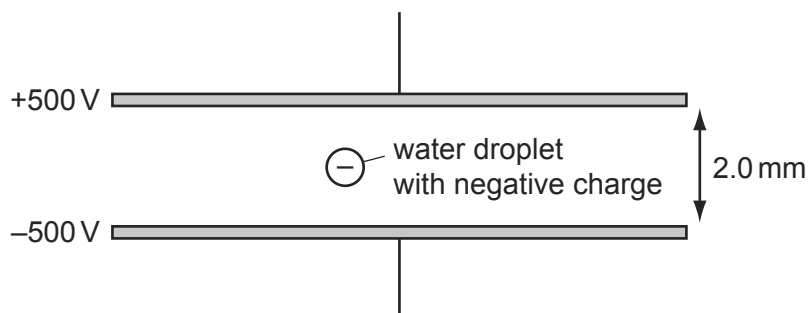

What is the motion of the droplet?

- A** It accelerates downwards.  
**B** It remains stationary.  
**C** It accelerates upwards.  
**D** It moves upwards at a constant velocity.
- 115 A horizontal bar is supported on a pivot at its centre of gravity. A fixed load is attached to one end of the bar. To keep the bar in equilibrium, a force  $F$  is applied at a distance  $x$  from the pivot.

9702/11/M/J/13/Q14

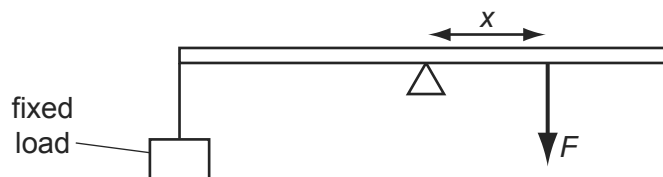

How does  $F$  vary with  $x$ ?

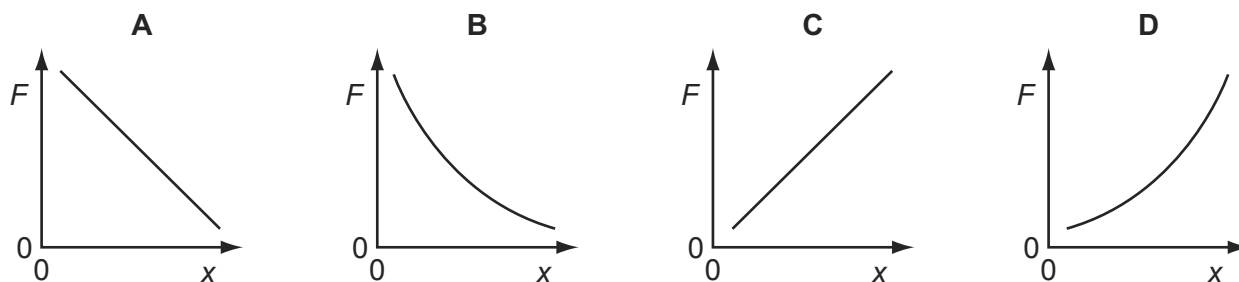

116 A hinged trapdoor is held closed in the horizontal position by a cable.

9702/11/M/J/13/Q16

Three forces act on the trapdoor: the weight  $W$  of the door, the tension  $T$  in the cable and the force  $H$  at the hinge.

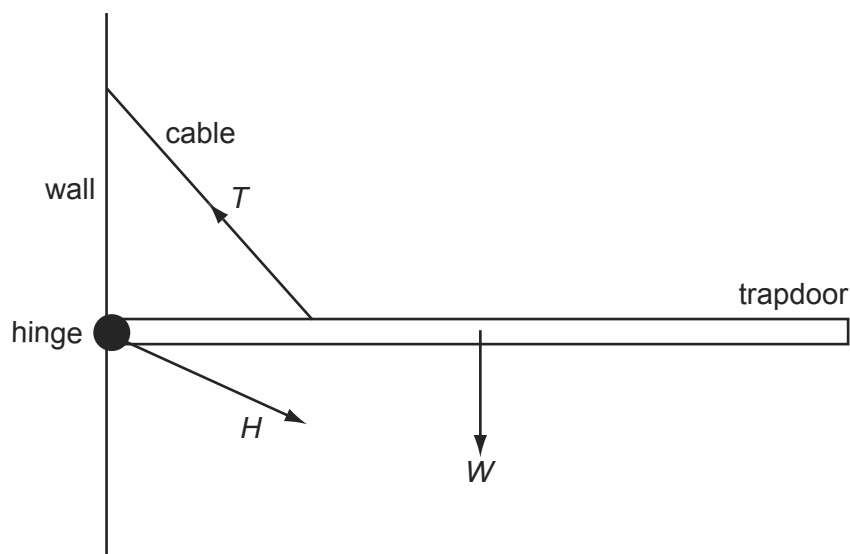

Which list gives the three forces in **increasing** order of magnitude?

- A**  $H, T, W$       **B**  $T, H, W$       **C**  $W, H, T$       **D**  $W, T, H$

117 A submarine is in equilibrium in a fully submerged position.

9702/12/M/J/13/Q11

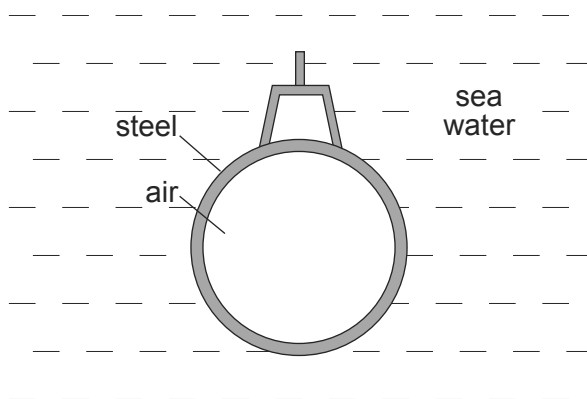

What causes the upthrust on the submarine?

- A** The air in the submarine is less dense than sea water.  
**B** The sea water exerts a greater upward force on the submarine than the weight of the steel.  
**C** The submarine displaces its own volume of sea water.  
**D** There is a difference in water pressure acting on the top and on the bottom of the submarine.

- 118 A vehicle is at rest on a slope. It is considered to have three forces acting on it to keep it in equilibrium.

9702/12/M/J/13/Q12

They are its weight  $W$ , a normal reaction force  $R$  and a frictional force  $F$ .

Which triangle of forces is correct?

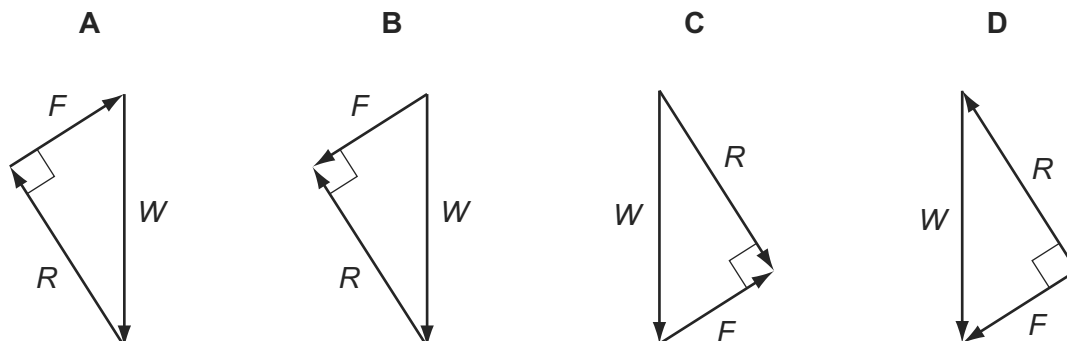

- 119 All external forces on a body cancel out.

9702/12/M/J/13/Q13

Which statement **must** be correct?

- A** The body does not move.  
**B** The momentum of the body remains unchanged.  
**C** The speed of the body remains unchanged.  
**D** The total energy (kinetic and potential) of the body remains unchanged.
- 120 A uniform beam of mass 1.4 kg is pivoted at P as shown. The beam has a length of 0.60 m and P is 0.20 m from one end. Loads of 3.0 kg and 6.0 kg are suspended 0.35 m and 0.15 m from the pivot as shown.

9702/12/M/J/13/Q14

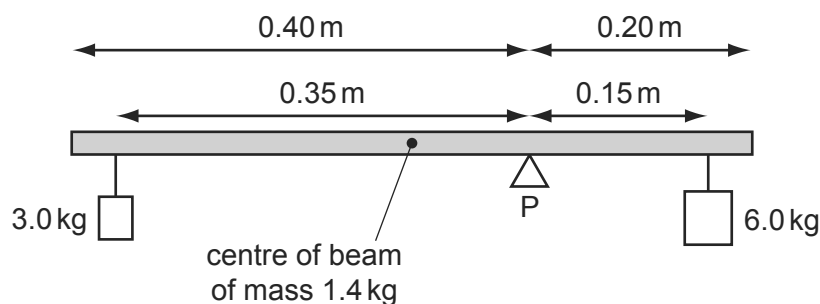

What torque must be applied to the beam in order to maintain it in equilibrium?

- A** 0.010 Nm    **B** 0.10 Nm    **C** 0.29 Nm    **D** 2.8 Nm

- 121 A lift (elevator) consists of a passenger car supported by a cable which runs over a light, frictionless pulley to a balancing weight. The balancing weight falls as the passenger car rises.

9702/13/M/J/13/Q9

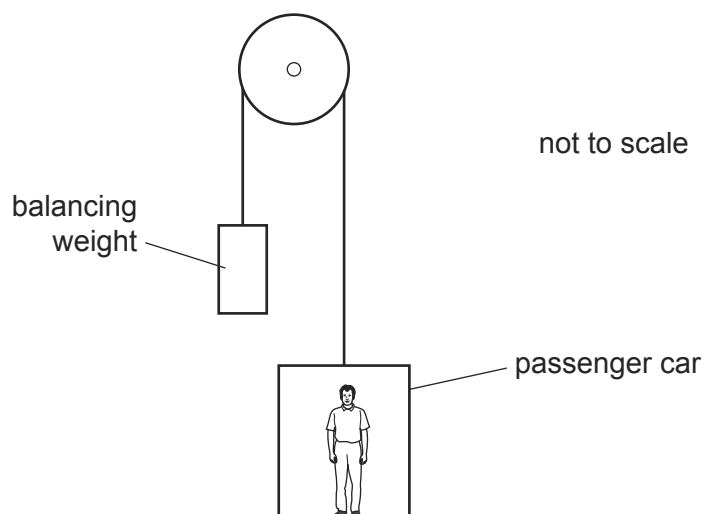

Some masses are shown in the table.

	mass / kg
passenger car	520
balancing weight	640
passenger	80

What is the magnitude of the acceleration of the car when carrying just one passenger and when the pulley is free to rotate?

- A**  $0.032 \text{ ms}^{-2}$     **B**  $0.32 \text{ ms}^{-2}$     **C**  $0.61 \text{ ms}^{-2}$     **D**  $0.65 \text{ ms}^{-2}$
- 122 A wooden block rests on a rough board. The end of the board is then raised until the block slides down the plane of the board at constant velocity  $v$ .

9702/13/M/J/13/Q13

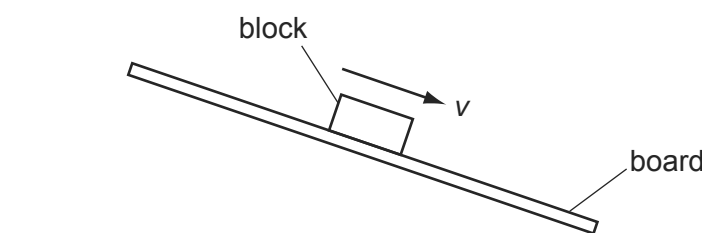

Which row describes the forces acting on the block when sliding with constant velocity?

	frictional force on block	resultant force on block
<b>A</b>	down the plane	down the plane
<b>B</b>	down the plane	zero
<b>C</b>	up the plane	down the plane
<b>D</b>	up the plane	zero

- 123 The diagrams show a negative electric charge situated in a uniform electric field and a mass situated in a uniform gravitational field.

9702/13/M/J/13/Q12

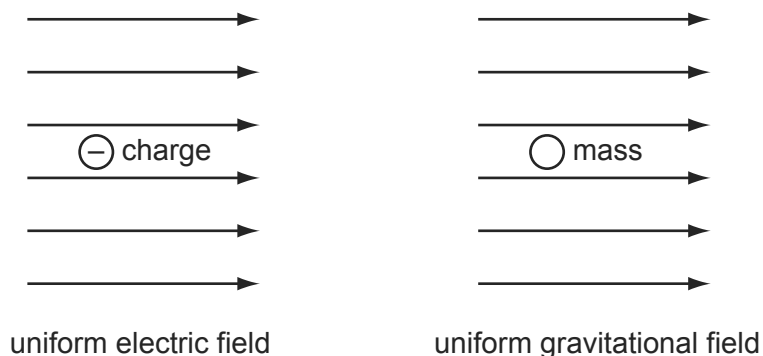

Which row shows the directions of the forces acting on the charge and on the mass?

	charge	mass
<b>A</b>		
<b>B</b>		
<b>C</b>		
<b>D</b>		

- 124 A uniform metre rule of weight 2.0 N is pivoted at the 60 cm mark. A 4.0 N weight is suspended from one end, causing the rule to rotate about the pivot.

9702/11/O/N/13/Q15

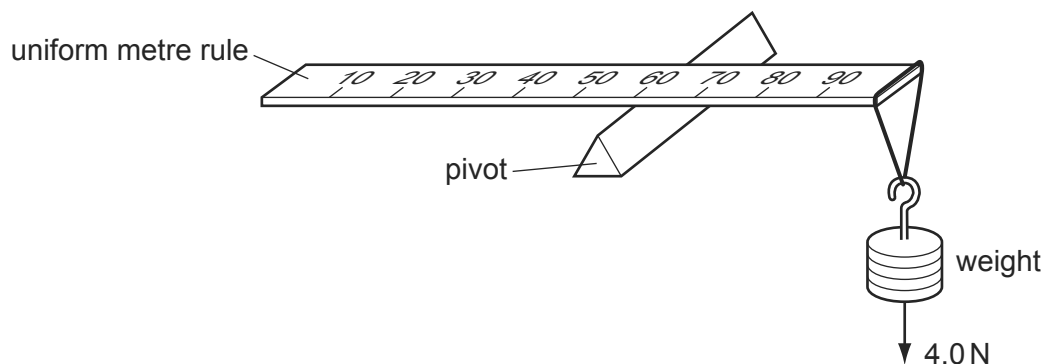

At the instant when the rule is horizontal, what is the resultant turning moment about the pivot?

- A** zero                      **B** 1.4 N m                      **C** 1.6 N m                      **D** 1.8 N m

- 125 An astronaut of mass  $m$  in a spacecraft experiences a gravitational force  $F = mg$  when stationary on the launchpad.

9702/11/O/N/13/Q10

What is the gravitational force on the astronaut when the spacecraft is launched vertically upwards with an acceleration of  $0.2g$ ?

- A**  $1.2mg$       **B**  $mg$       **C**  $0.8mg$       **D**  $0$

- 126 What is meant by the mass and by the weight of an object on the Earth?

9702/11/O/N/13/Q9

	mass	weight
<b>A</b>	its momentum divided by its velocity	the work done in lifting it one metre
<b>B</b>	the gravitational force on it	the property that resists its acceleration
<b>C</b>	the pull of the Earth on it	its mass divided by the acceleration of free fall
<b>D</b>	the property that resists its acceleration	the pull of the Earth on it

- 127 A man holds a 100 N load stationary in his hand. The combined weight of the forearm and hand is 20 N. The forearm is held horizontal, as shown.

9702/11/M/J/14/Q12

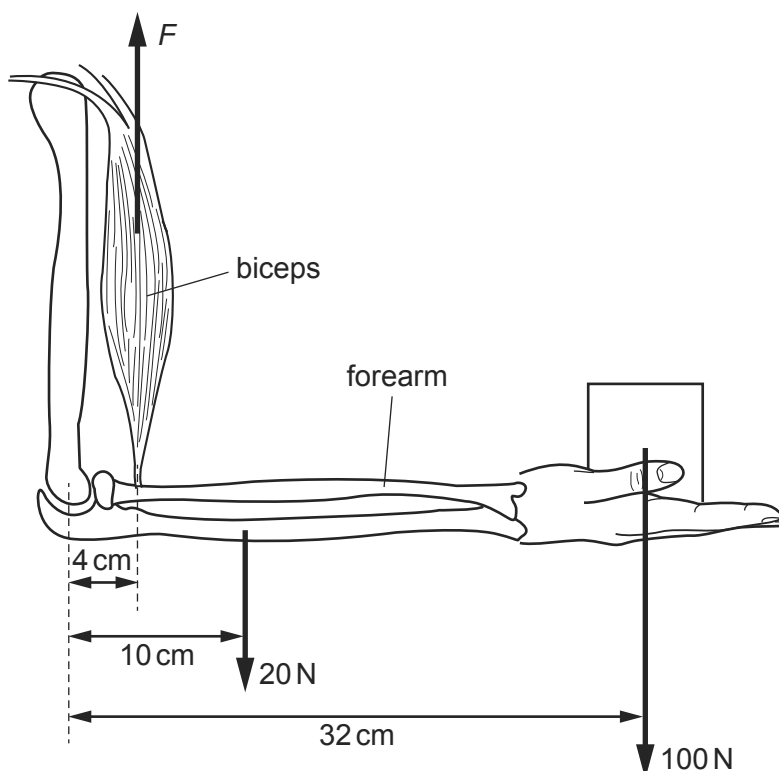

What is the vertical force  $F$  needed in the biceps?

- A** 750 N      **B** 800 N      **C** 850 N      **D** 900 N

128 A cupboard is attached to a wall by a screw.

9702/13/O/N/13/Q14

Which force diagram shows the cupboard in equilibrium, with the weight  $W$  of the cupboard, the force  $S$  that the screw exerts on the cupboard and the force  $R$  that the wall exerts on the cupboard?

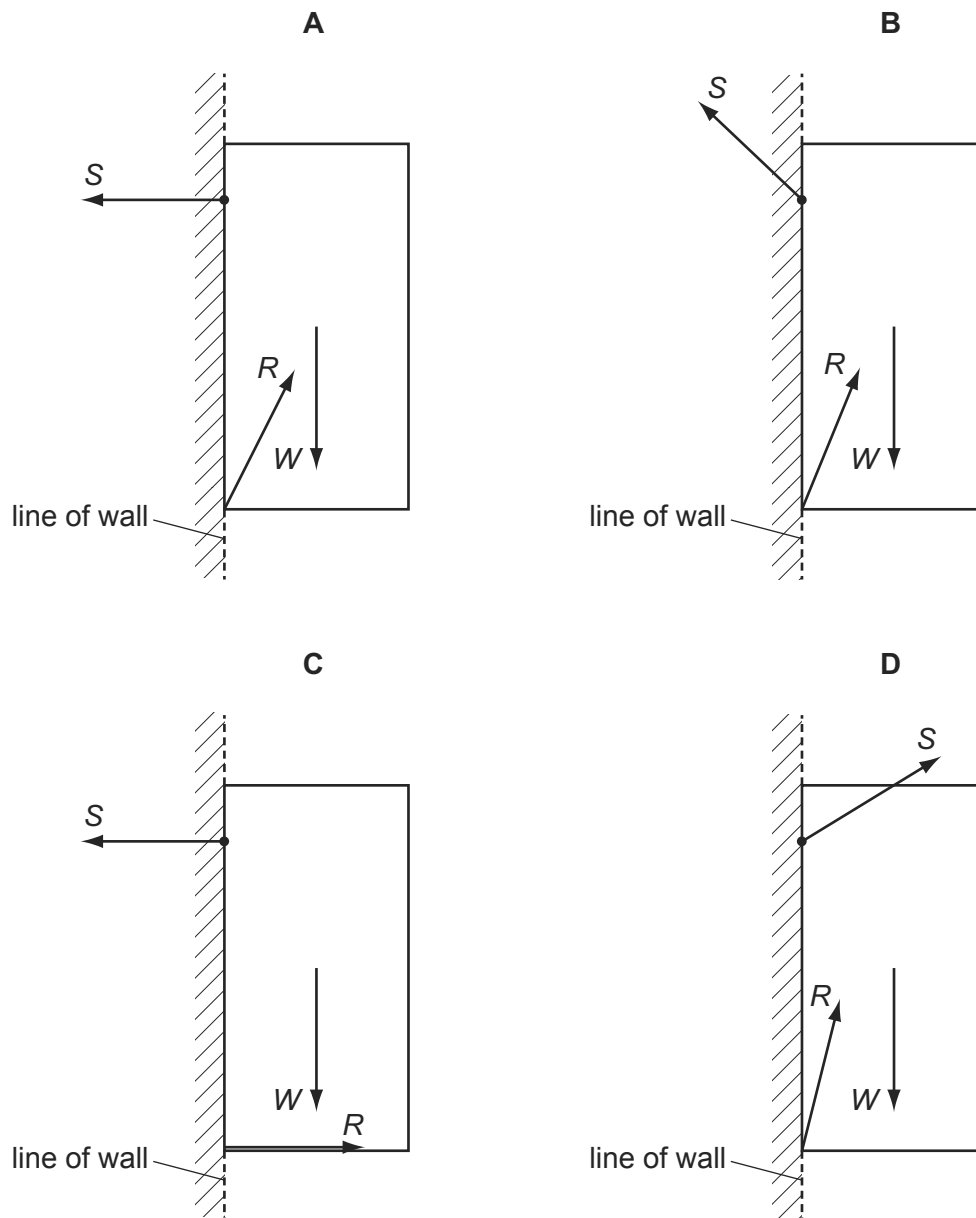

129 The diagrams show two ways of hanging the same picture.

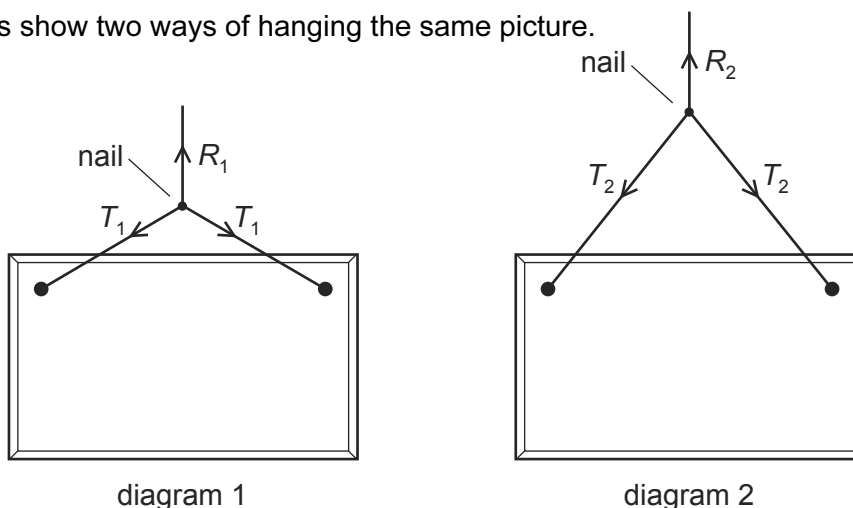

In both cases, a string is attached to the same points on the picture and looped symmetrically over a nail in a wall. The forces shown are those that act on the nail.

In diagram 1, the string loop is shorter than in diagram 2.

Which information about the magnitude of the forces is correct?

- A**  $R_1 = R_2$        $T_1 = T_2$
- B**  $R_1 = R_2$        $T_1 > T_2$
- C**  $R_1 > R_2$        $T_1 < T_2$
- D**  $R_1 < R_2$        $T_1 = T_2$

130 A diving board of length 5.0 m is hinged at one end and supported 2.0 m from this end by a spring of spring constant  $10 \text{ kN m}^{-1}$ . A child of mass 40 kg stands at the far end of the board. 9702/13/O/N/13/Q15

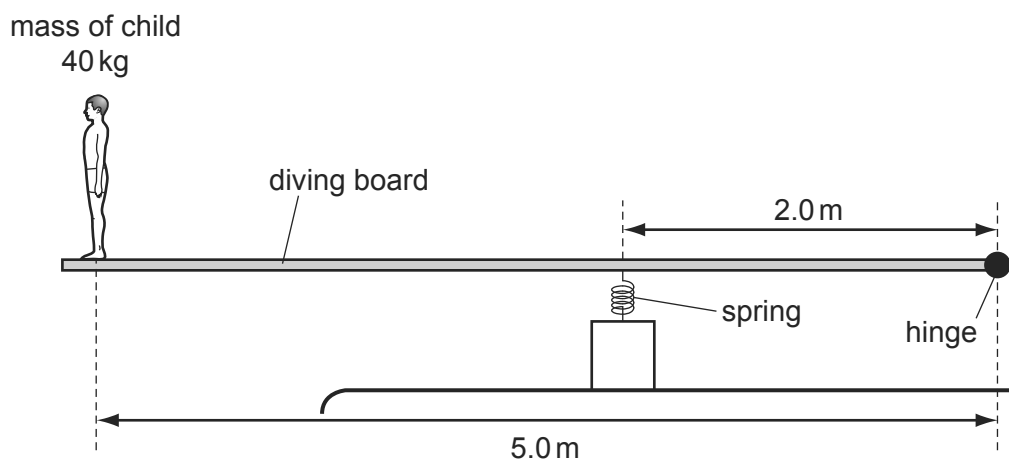

What is the extra compression of the spring caused by the child standing on the end of the board?

- A** 1.0 cm
- B** 1.6 cm
- C** 9.8 cm
- D** 16 cm



131 The diagram shows four forces applied to a circular object.

9702/12/M/J/14/Q13

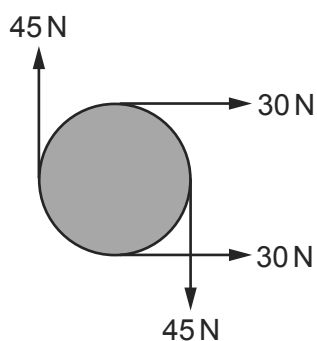

Which of the following describes the resultant force and resultant torque on the object?

	resultant force	resultant torque
<b>A</b>	non-zero	non-zero
<b>B</b>	non-zero	zero
<b>C</b>	zero	non-zero
<b>D</b>	zero	zero

132 A spindle is attached at one end to the centre of a lever of length 1.20 m and at its other end to the centre of a disc of radius 0.20 m. A string is wrapped round the disc, passes over a pulley and is attached to a 900 N weight.

9702/11/M/J/14/Q13

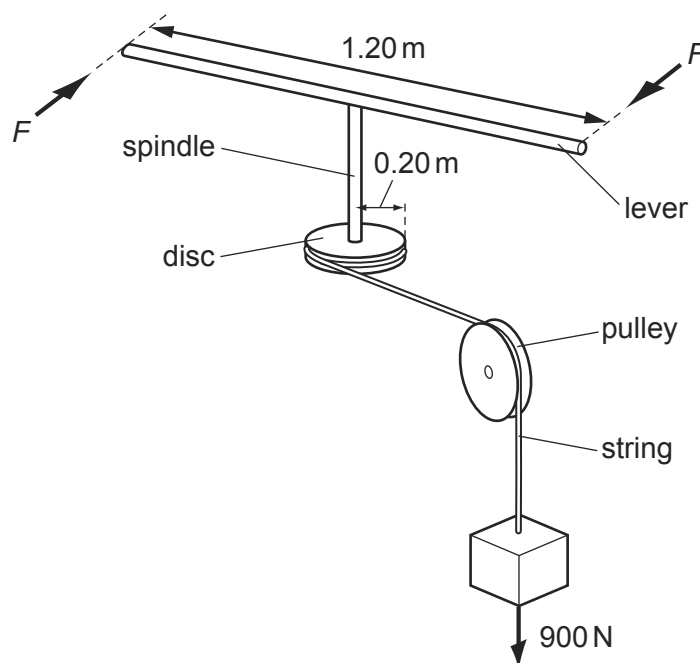

What is the minimum force  $F$ , applied to each end of the lever, that could lift the weight?

- A** 75 N      **B** 150 N      **C** 300 N      **D** 950 N

- 133 A tiny oil droplet with mass  $6.9 \times 10^{-13}$  kg is at rest in an electric field of electric field strength  $2.1 \times 10^7$  NC<sup>-1</sup>, as shown.

9702/12/M/J/14/Q12

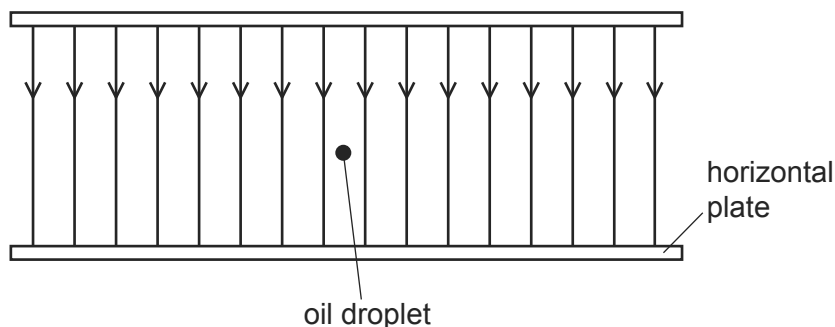

The weight of the droplet is exactly balanced by the electrical force on the droplet.

What is the charge on the droplet?

- A**  $3.3 \times 10^{-20}$  C  
**B**  $-3.3 \times 10^{-20}$  C  
**C**  $3.2 \times 10^{-19}$  C  
**D**  $-3.2 \times 10^{-19}$  C
- 134 The graph shows the variation with time of the speed of a raindrop falling vertically through air.

9702/12/M/J/14/Q11

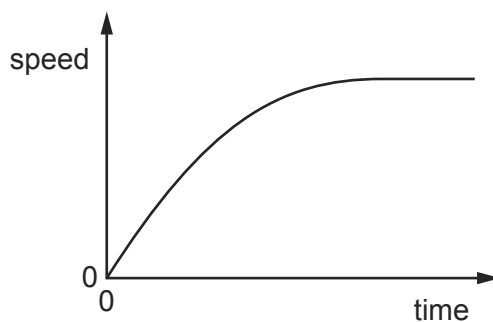

Which statement is correct?

- A** The acceleration decreases to produce a steady speed.  
**B** The acceleration increases as the speed increases.  
**C** The air resistance decreases as the speed increases.  
**D** The resultant force increases as the speed increases.

135 What is the condition for an object to be in equilibrium?

- A The object's velocity and the resultant torque on it must both be zero.
- B The object's velocity must be zero.
- C The resultant force and the resultant torque on the object must both be zero.
- D The resultant force on the object must be zero.

136 A uniform beam is pivoted at P as shown. Weights of 10 N and 20 N are attached to its ends.

The length of the beam is marked at 0.1 m intervals. The weight of the beam is 100 N.

At which point should a further weight of 20 N be attached to achieve equilibrium?

9702/13/M/J/14/Q15

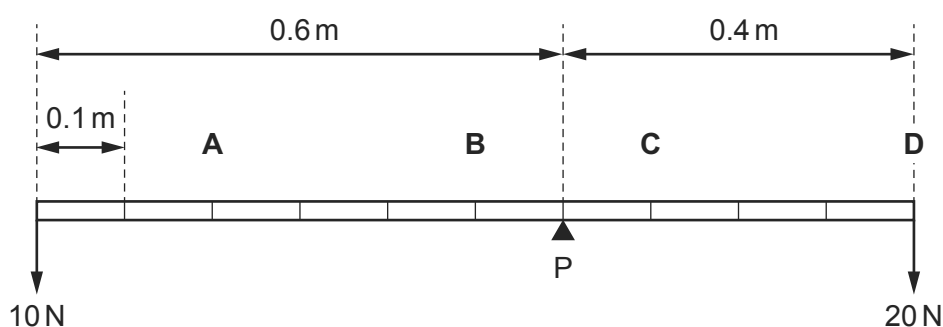

137 A uniform solid cuboid of concrete of dimensions  $0.50\text{ m} \times 1.20\text{ m} \times 0.40\text{ m}$  and weight 4000 N rests on a flat surface with the 1.20 m edge vertical as shown in diagram 1.

9702/13/M/J/14/Q14

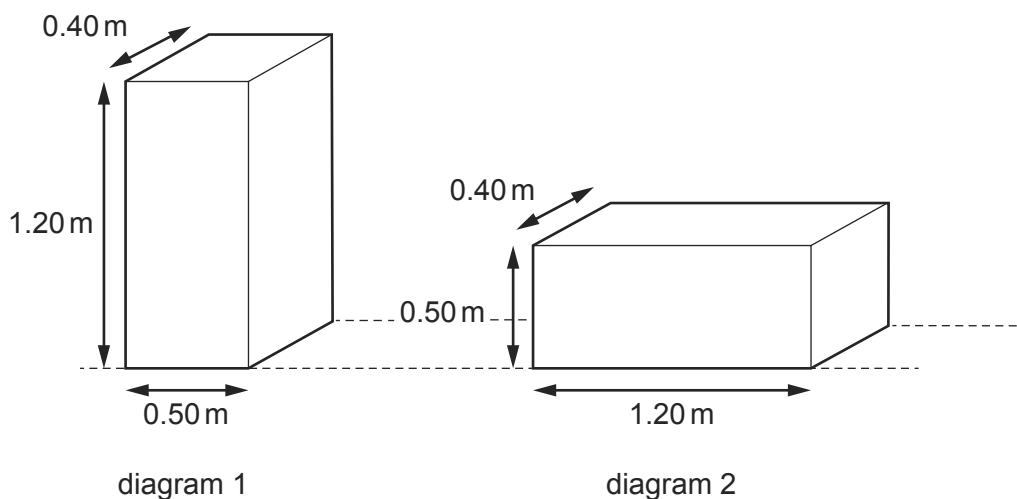

What is the minimum energy required to roll the cuboid through  $90^\circ$  to the position shown in diagram 2 with the 0.50 m edge vertical?

- A 200 J
- B 400 J
- C 1400 J
- D 2600 J

- 138 A cylinder of weight  $W$  is placed on a smooth slope. The contact force of the slope on the cylinder is  $R$ . A thread is attached to the surface of the cylinder. The other end of the thread is fixed.

9702/13/O/N/14/Q13

Which diagram shows the cylinder in equilibrium?

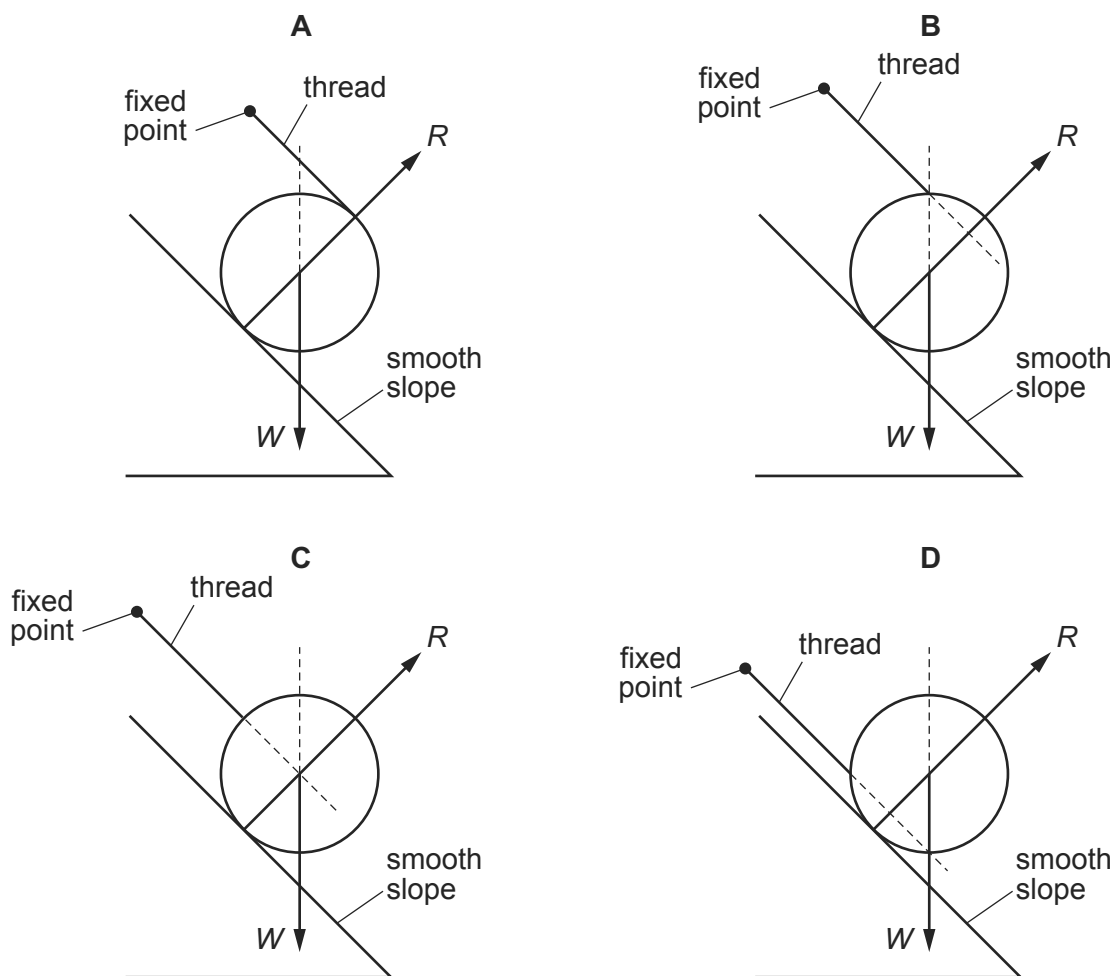

- 139 A sealed cylindrical steel can is situated below the surface of water.

9702/13/O/N/14/Q12

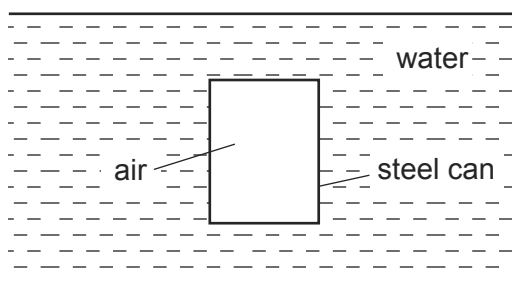

What is the origin of the upthrust that acts on the can?

- A The air pressure in the can is less than the water pressure outside the can.
- B The average density of the air and steel is less than the density of water.
- C The water pressure on the bottom of the can is greater than the water pressure on the top.
- D The weight of displaced water acts upwards on the can.

- 140 A uniform metre rule of mass 100 g is supported by a pivot at the 40 cm mark and a string at the 100 cm mark. The string passes round a frictionless pulley and carries a mass of 20 g as shown in the diagram.

9702/13/O/N/14/Q14

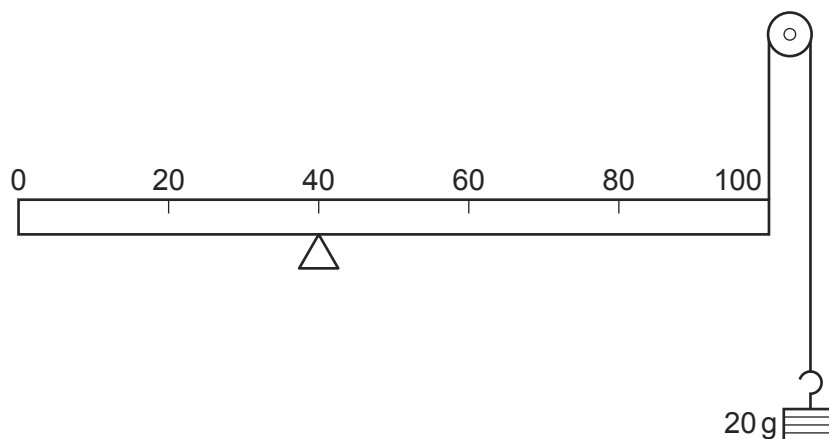

At which mark on the rule must a 50 g mass be suspended so that the rule balances?

- A** 4 cm                      **B** 36 cm                      **C** 44 cm                      **D** 64 cm
- 141 A glider is descending at constant speed at an angle of  $15^\circ$  to the horizontal. The diagram shows the directions of the lift  $L$ , air resistance  $R$  and weight  $W$  acting on the glider.

9702/11/O/N/14/Q10

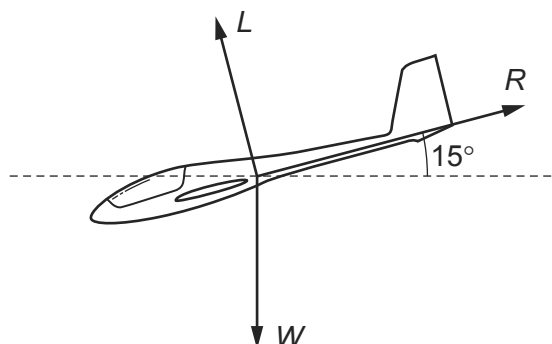

Which vector triangle could represent the forces acting on the glider?

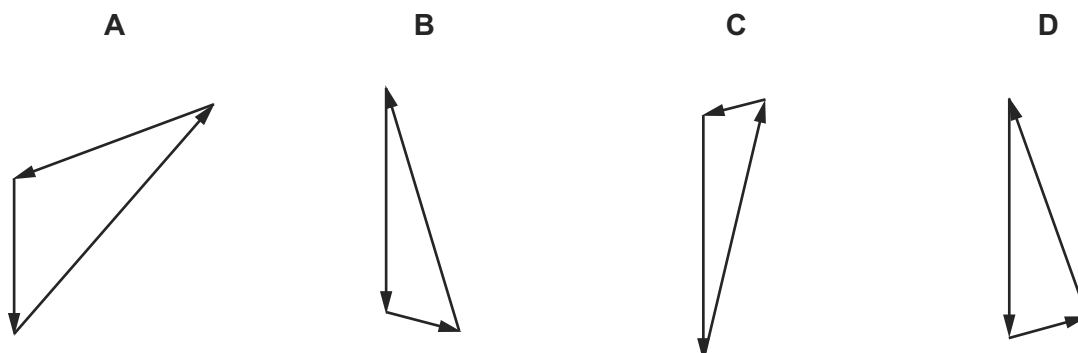

- 142 A ball is falling at terminal speed in still air. The forces acting on the ball are upthrust, viscous drag and weight.

9702/11/O/N/14/Q11

What is the order of increasing magnitude of these three forces?

- A** upthrust  $\rightarrow$  viscous drag  $\rightarrow$  weight  
**B** viscous drag  $\rightarrow$  upthrust  $\rightarrow$  weight  
**C** viscous drag  $\rightarrow$  weight  $\rightarrow$  upthrust  
**D** weight  $\rightarrow$  upthrust  $\rightarrow$  viscous drag
- 143 A uniform ladder rests against a vertical wall where there is negligible friction. The bottom of the ladder rests on rough ground where there is friction. The top of the ladder is at a height  $h$  above the ground and the foot of the ladder is at a distance  $2a$  from the wall.

9702/11/O/N/14/Q12

The diagram shows the forces that act on the ladder.

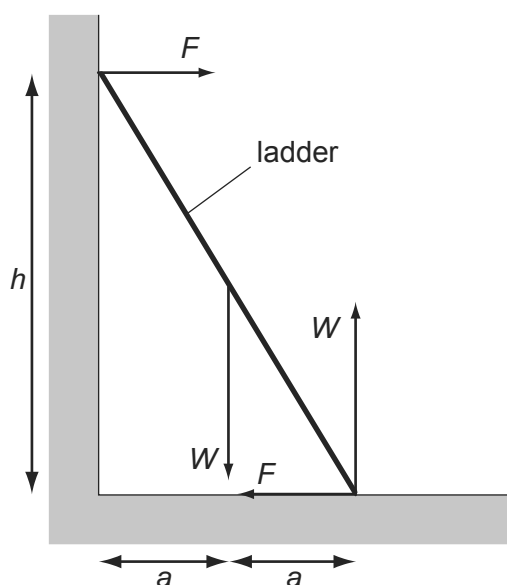

Which equation is formed by taking moments?

- A**  $Wa + Fh = 2Wa$   
**B**  $Fa + Wa = Fh$   
**C**  $Wa + 2Wa = Fh$   
**D**  $Wa - 2Wa = 2Fh$

- 144 Four cuboids with identical length, breadth and height are immersed in water. The cuboids are held at the same depth and in identical orientations by vertical rods, as shown.

9702/13/M/J/15/Q14

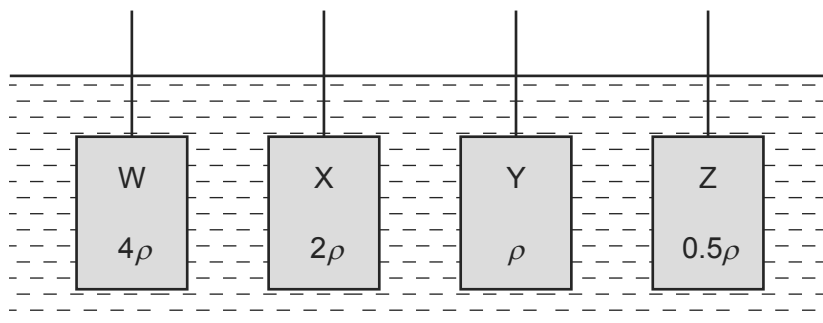

Water has density  $\rho$ .

Cuboid W is made of material of density  $4\rho$ .

Cuboid X is made of material of density  $2\rho$ .

Cuboid Y is made of material of density  $\rho$ .

Cuboid Z is made of material of density  $0.5\rho$ .

Which statement is correct?

- A** The upthrust of the water on each of the cuboids is the same.
- B** The upthrust of the water on W is twice the upthrust of the water on X.
- C** The upthrust of the water on X is twice the upthrust of the water on W.
- D** The upthrust of the water on Y is zero.
- 145 The diagrams represent systems of coplanar forces acting at a point. The lengths of the force vectors represent the magnitudes of the forces.

9702/13/M/J/15/Q16

Which system of forces is in equilibrium?

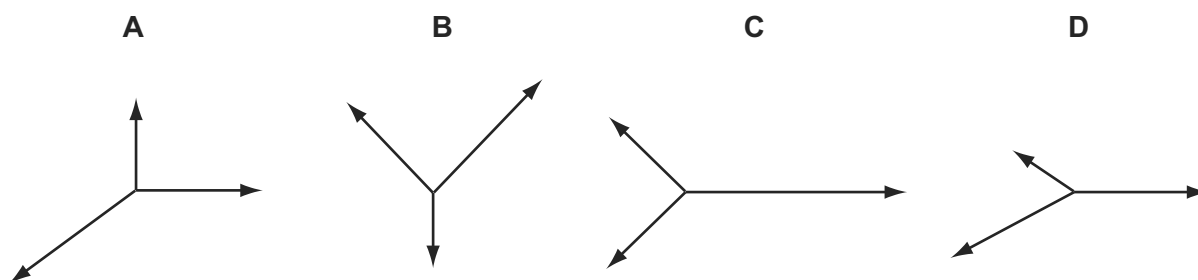

- 146 What is a reasonable estimate of the average gravitational force acting on a fully grown woman standing on the Earth?

9702/11/M/J/15/Q10

- A** 60 N      **B** 250 N      **C** 350 N      **D** 650 N

- 147 An air bubble in a tank of water is rising with constant velocity. The forces acting on the bubble are  $X$ ,  $Y$  and  $Z$  as shown.

9702/13/M/J/15/Q15

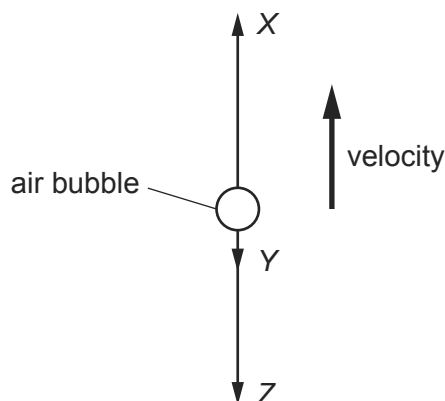

What describes the three forces?

- A**  $Z$  is the viscous drag on the bubble,  $Y$  is the weight of the bubble,  $X$  is the upthrust on the bubble and  $X = Y + Z$ .
- B**  $Z$  is the viscous drag on the bubble,  $Y$  is the weight of the bubble,  $X$  is the upthrust on the bubble and  $X > Y + Z$ .
- C**  $Z$  is the weight of the bubble,  $Y$  is the viscous drag on the bubble,  $X$  is the upthrust on the bubble and  $X = Y + Z$ .
- D**  $Z$  is the weight of the bubble,  $Y$  is the viscous drag on the bubble,  $X$  is the upthrust on the bubble and  $X > Y + Z$ .
- 148 A child on a sledge slides down a hill with acceleration  $a$ . The hill makes an angle  $\theta$  with the horizontal.

9702/11/M/J/15/Q12

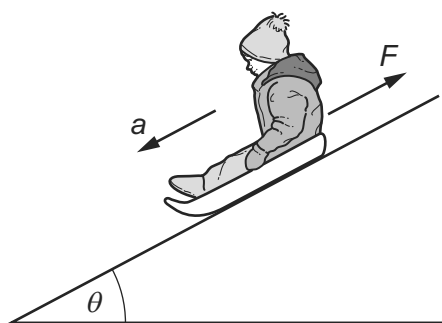

The total mass of the child and the sledge is  $m$ . The acceleration of free fall is  $g$ .

What is the friction force  $F$ ?

- A**  $m(g \cos \theta - a)$
- B**  $m(g \cos \theta + a)$
- C**  $m(g \sin \theta - a)$
- D**  $m(g \sin \theta + a)$



- 149 A ladder is positioned on icy (frictionless) ground and is leant against a rough wall. At the instant of release it begins to slide.

9702/12/M/J/15/Q14

Which diagram correctly shows the directions of the forces  $P$ ,  $W$  and  $R$  acting on the ladder as it slides?

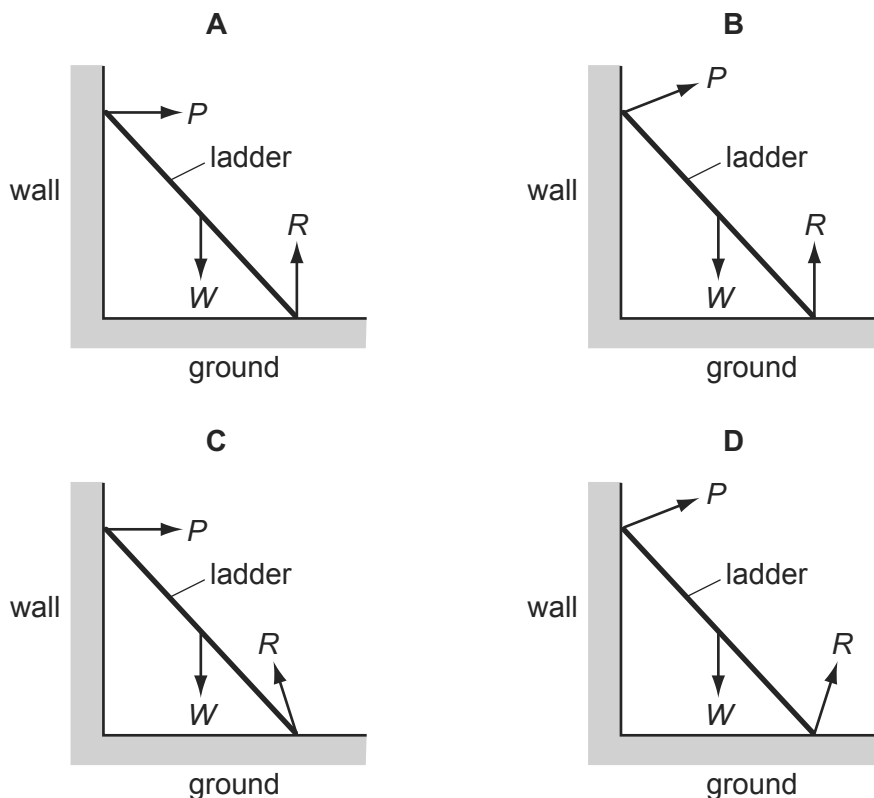

- 150 A uniform metre rule is pivoted at the 34.0 cm mark, as shown.

9702/11/M/J/15/Q15

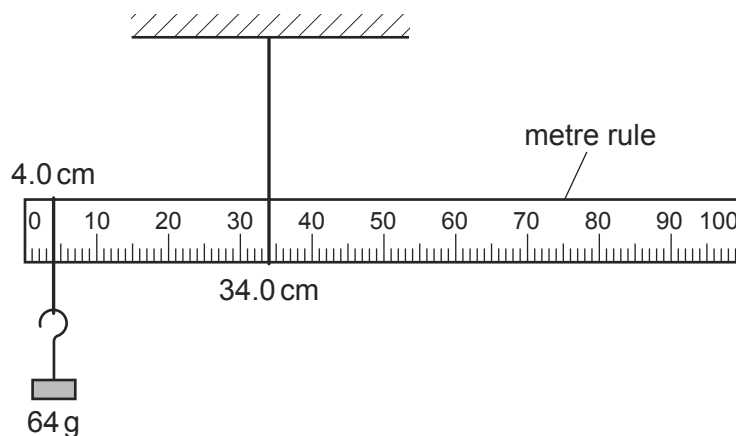

The rule balances when a 64 g mass is hung from the 4.0 cm mark.

What is the mass of the metre rule?

- A** 38 g      **B** 44 g      **C** 120 g      **D** 136 g

- 151 A box of mass 8.0 kg rests on a horizontal rough surface. A string attached to the box passes over a smooth pulley and supports a 2.0 kg mass at its other end.

9702/11/M/J/15/Q13

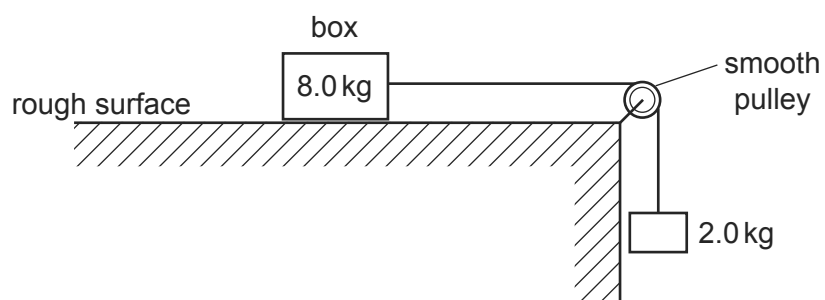

When the box is released, a frictional force of 6.0 N acts on it.

What is the acceleration of the box?

- A**  $1.4 \text{ m s}^{-2}$       **B**  $1.7 \text{ m s}^{-2}$       **C**  $2.0 \text{ m s}^{-2}$       **D**  $2.6 \text{ m s}^{-2}$

- 1 Two similar spheres, each of mass  $m$  and travelling with speed  $v$ , are moving towards each other.

9702/1/M/J/02/Q9



The spheres have a head-on elastic collision.

Which statement is correct?

- A** The spheres stick together on impact.  
**B** The total kinetic energy after impact is  $mv^2$ .  
**C** The total kinetic energy before impact is zero.  
**D** The total momentum before impact is  $2mv$ .
- 2 A body, initially at rest, explodes into two masses  $M_1$  and  $M_2$  that move apart with speeds  $v_1$  and  $v_2$  respectively.

9702/1/M/J/02/Q11

What is the ratio  $\frac{v_1}{v_2}$ ?

- A**  $\frac{M_1}{M_2}$       **B**  $\frac{M_2}{M_1}$       **C**  $\left(\frac{M_1}{M_2}\right)^{\frac{1}{2}}$       **D**  $\left(\frac{M_2}{M_1}\right)^{\frac{1}{2}}$

- 3 Two spheres A and B approach each other along the same straight line with speeds  $u_A$  and  $u_B$ . The spheres collide and move off with speeds  $v_A$  and  $v_B$ , both in the same direction as the initial direction of sphere A, as shown below.

9702/1/O/N/02/Q11

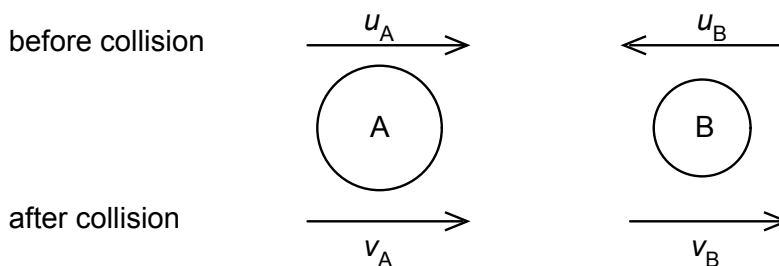

Which equation applies to an elastic collision?

- A**  $u_A + u_B = v_B - v_A$   
**B**  $u_A - u_B = v_B - v_A$   
**C**  $u_A - u_B = v_B + v_A$   
**D**  $u_A + u_B = v_B + v_A$

- 4 Two equal masses travel towards each other on a frictionless air track at speeds of  $60 \text{ cm s}^{-1}$  and  $30 \text{ cm s}^{-1}$ . They stick together on impact. 9702/1/O/N/02/Q12



What is the speed of the masses after impact?

- A  $15 \text{ cm s}^{-1}$     B  $20 \text{ cm s}^{-1}$     C  $30 \text{ cm s}^{-1}$     D  $45 \text{ cm s}^{-1}$
- 5 Two blocks X and Y, of masses  $m$  and  $3m$  respectively, are accelerated along a smooth horizontal surface by a force  $F$  applied to block X as shown. 9702/01/M/J/03/Q10

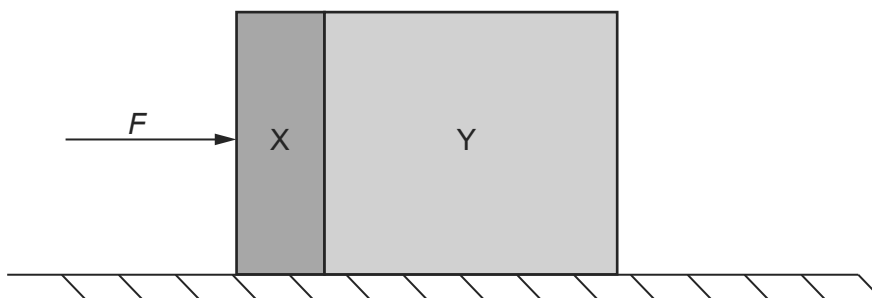

What is the magnitude of the force exerted by block X on block Y during this acceleration?

- A  $\frac{F}{4}$     B  $\frac{F}{3}$     C  $\frac{F}{2}$     D  $\frac{3F}{4}$
- 6 A ball of mass  $2 \text{ kg}$  travelling at  $8 \text{ m s}^{-1}$  strikes a ball of mass  $4 \text{ kg}$  travelling at  $2 \text{ m s}^{-1}$ . Both balls are moving along the same straight line as shown. 9702/01/M/J/03/Q12

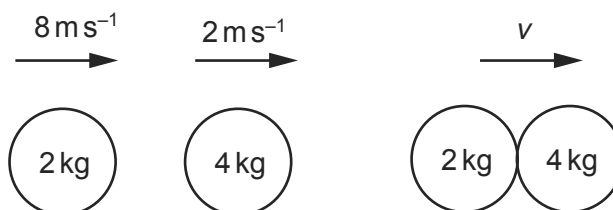

After collision, both balls move at the same velocity  $v$ .

What is the magnitude of the velocity  $v$ ?

- A  $4 \text{ m s}^{-1}$     B  $5 \text{ m s}^{-1}$     C  $6 \text{ m s}^{-1}$     D  $8 \text{ m s}^{-1}$

7 A mass accelerates uniformly when the resultant force acting on it

9702/01/O/N/03/Q10

- A is zero.
- B is constant but not zero.
- C increases uniformly with respect to time.
- D is proportional to the displacement from a fixed point.

8 A molecule of mass  $m$  travelling horizontally with velocity  $u$  hits a vertical wall at right angles to the wall. It then rebounds horizontally with the same speed.

9702/01/O/N/03/Q11

What is its change in momentum?

- A zero
- B  $mu$
- C  $-mu$
- D  $-2mu$

9 Two balls X and Y approach each other along the same straight line and collide elastically.

Their speeds are  $u_X$  and  $u_Y$  respectively. After the collision they move apart with speeds  $v_X$  and  $v_Y$  respectively. Their directions are shown on the diagram.

9702/01/O/N/03/Q12

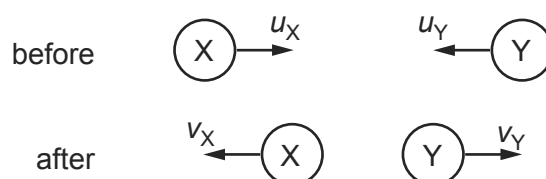

Which of the following equations is correct?

- A  $u_X + u_Y = v_X + v_Y$
- B  $u_X + u_Y = v_X - v_Y$
- C  $u_X - u_Y = v_X + v_Y$
- D  $u_X - u_Y = v_X - v_Y$

10 Two equal masses travel towards each other on a frictionless air track at speeds of  $60 \text{ cm s}^{-1}$  and  $40 \text{ cm s}^{-1}$ . They stick together on impact.

9702/01/M/J/05/Q11



What is the speed of the masses after impact?

- A  $10 \text{ cm s}^{-1}$
- B  $20 \text{ cm s}^{-1}$
- C  $40 \text{ cm s}^{-1}$
- D  $50 \text{ cm s}^{-1}$

- 11 A ball falls vertically and bounces on the ground.

9702/01/M/J/04/Q10

The following statements are about the forces acting while the ball is in contact with the ground.

Which statement is correct?

- A** The force that the ball exerts on the ground is always equal to the weight of the ball.
- B** The force that the ball exerts on the ground is always equal in magnitude and opposite in direction to the force the ground exerts on the ball.
- C** The force that the ball exerts on the ground is always less than the weight of the ball.
- D** The weight of the ball is always equal in magnitude and opposite in direction to the force that the ground exerts on the ball.
- 12 The diagram shows a situation just before a head-on collision. A lorry of mass 20 000 kg is travelling at  $20.0 \text{ m s}^{-1}$  towards a car of mass 900 kg travelling at  $30.0 \text{ m s}^{-1}$  towards the lorry.

9702/01/M/J/04/Q11

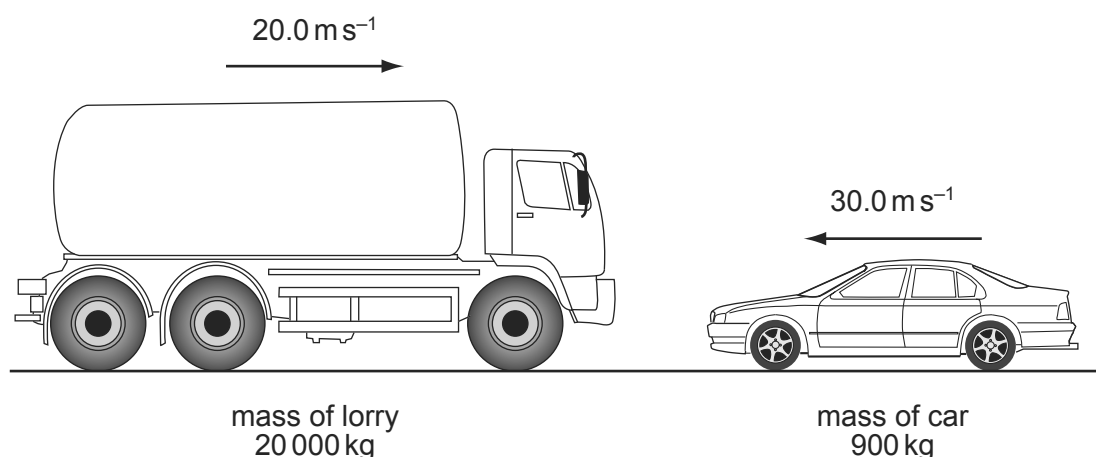

What is the magnitude of the total momentum?

- A** 373 kNs      **B** 427 kNs      **C** 3600 kNs      **D** 4410 kNs
- 13 Which of the following is a statement of the principle of conservation of momentum? 9702/01/O/N/03/Q9
- A** Momentum is the product of mass and velocity.
- B** In an elastic collision, momentum is constant.
- C** The momentum of an isolated system is constant.
- D** The force acting on a body is proportional to its rate of change of momentum.
- 14 Two railway trucks of masses  $m$  and  $3m$  move towards each other in opposite directions with speeds  $2v$  and  $v$  respectively. These trucks collide and stick together. 9702/01/M/J/06/Q12

What is the speed of the trucks after the collision?

- A**  $\frac{v}{4}$       **B**  $\frac{v}{2}$       **C**  $v$       **D**  $\frac{5v}{4}$

- 15 A particle of mass  $m$  strikes a vertical rigid wall perpendicularly from the left with velocity  $v$ .

9702/01/O/N/04/Q11

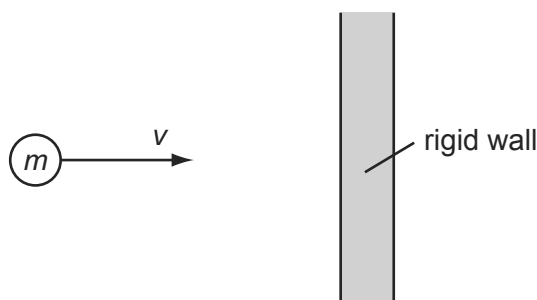

If the collision is perfectly elastic, the total change in momentum of the particle that occurs as a result of the collision is

- A**  $2mv$  to the right.
- B**  $2mv$  to the left.
- C**  $mv$  to the right.
- D**  $mv$  to the left.
- 16 Which is **not** one of Newton's laws of motion? 9702/01/M/J/05/Q10
- A** The total momentum of a system of interacting bodies remains constant, providing no external force acts.
- B** The rate of change of momentum of a body is directly proportional to the external force acting on the body and takes place in the direction of the force.
- C** If body A exerts a force on body B, then body B exerts an equal and oppositely-directed force on body A.
- D** A body continues in a state of rest or of uniform motion in a straight line unless acted upon by some external force.
- 17 A constant mass undergoes uniform acceleration. 9702/01/O/N/04/Q10
- Which of the following is a correct statement about the resultant force acting on the mass?
- A** It increases uniformly with respect to time.
- B** It is constant but not zero.
- C** It is proportional to the displacement from a fixed point.
- D** It is proportional to the velocity.
- 18 What is the centre of gravity of an object? 9702/01/M/J/05/Q12
- A** the geometrical centre of the object
- B** the point about which the total torque is zero
- C** the point at which the weight of the object may be considered to act
- D** the point through which gravity acts

- 19 Which is a statement of the principle of conservation of momentum? 9702/01/O/N/05/Q9
- A** A force is equal to the rate of change of momentum of the body upon which it acts.
- B** In a perfectly elastic collision, the relative momentum of the bodies before impact is equal to their relative momentum after impact.
- C** The momentum of a body is the product of the mass of the body and its velocity.
- D** The total momentum of a system of interacting bodies remains constant, providing no external force acts.

- 20 The gravitational field strength on the surface of planet P is one tenth of that on the surface of planet Q. 9702/01/O/N/05/Q10

On the surface of P, a body has its mass measured to be 1.0 kg and its weight measured to be 1.0 N.

What results are obtained for measurements of the mass and weight of the same body on the surface of planet Q?

	mass on Q	weight on Q
<b>A</b>	1.0 kg	0.1 N
<b>B</b>	1.0 kg	10 N
<b>C</b>	10 kg	10 N
<b>D</b>	10 kg	100 N

- 21 A cyclist is riding at a steady speed on a level road. 9702/01/M/J/06/Q10

According to Newton's third law of motion, what is equal and opposite to the backward push of the back wheel on the road?

- A** the force exerted by the cyclist on the pedals
- B** the forward push of the road on the back wheel
- C** the tension in the cycle chain
- D** the total air resistance and friction force
- 22 In perfectly elastic collisions between two atoms, it is always true to say that 9702/01/M/J/06/Q11
- A** the initial speed of one atom will be the same as the final speed of the other atom.
- B** the relative speed of approach between the two atoms equals their relative speed of separation.
- C** the total momentum must be conserved, but a small amount of the total kinetic energy may be lost in the collision.
- D** whatever their initial states of motion, neither atom can be stationary after the collision.



- 23 A force  $F$  is applied to a freely moving object. At one instant of time, the object has velocity  $v$  and acceleration  $a$ . 9702/01/O/N/06/Q10

Which quantities **must** be in the same direction?

- A**  $a$  and  $v$  only  
**B**  $a$  and  $F$  only  
**C**  $v$  and  $F$  only  
**D**  $v$ ,  $F$  and  $a$

- 24 The diagram shows two identical spheres X and Y. 9702/01/O/N/06/Q11

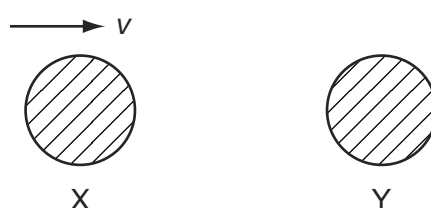

Initially X moves with speed  $v$  directly towards Y. Y is stationary. The spheres collide elastically.

What happens?

	X	Y
<b>A</b>	moves with speed $\frac{1}{2}v$ to the right	moves with speed $\frac{1}{2}v$ to the right
<b>B</b>	moves with speed $v$ to the left	remains stationary
<b>C</b>	moves with speed $\frac{1}{2}v$ to the left	moves with speed $\frac{1}{2}v$ to the right
<b>D</b>	stops	moves with speed $v$ to the right

- 25 The diagram shows a cannon ball fired from a cannon. 9702/01/O/N/06/Q12

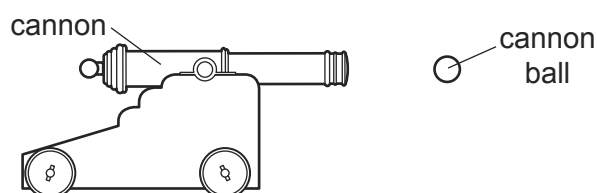

The mass of the cannon is 1000 kg and the mass of the cannon ball is 10 kg.

The recoil velocity of the cannon is  $5 \text{ m s}^{-1}$  horizontally.

What is the horizontal velocity of the cannon ball?

- A**  $200 \text{ m s}^{-1}$       **B**  $500 \text{ m s}^{-1}$       **C**  $2000 \text{ m s}^{-1}$       **D**  $5000 \text{ m s}^{-1}$

- 26 An object has an initial velocity  $u$ . It is subjected to a constant force  $F$  for  $t$  seconds, causing a constant acceleration  $a$ . The force is **not** in the same direction as the initial velocity. 9702/01/M/J/07/Q7

A vector diagram is drawn to find the final velocity  $v$ .

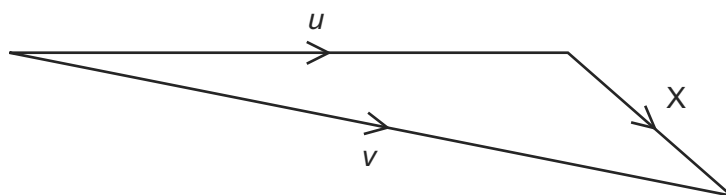

What is the length of side X of the vector diagram?

- A**  $F$                       **B**  $Ft$                       **C**  $at$                       **D**  $u + at$
- 27 What is meant by the weight of an object? 9702/01/M/J/07/Q9
- A** the gravitational field acting on the object  
**B** the gravitational force acting on the object  
**C** the mass of the object multiplied by gravity  
**D** the object's mass multiplied by its acceleration
- 28 The graph shows the variation with time of the momentum of a ball as it is kicked in a straight line. 9702/01/M/J/07/Q10

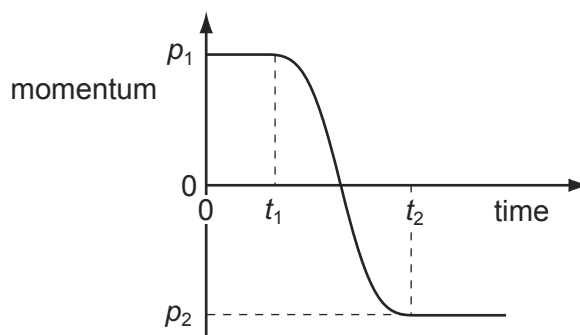

Initially, the momentum is  $p_1$  at time  $t_1$ . At time  $t_2$  the momentum is  $p_2$ .

What is the magnitude of the average force acting on the ball between times  $t_1$  and  $t_2$ ?

- A**  $\frac{p_1 - p_2}{t_2}$                       **B**  $\frac{p_1 - p_2}{t_2 - t_1}$                       **C**  $\frac{p_1 + p_2}{t_2}$                       **D**  $\frac{p_1 + p_2}{t_2 - t_1}$
- 29 Which statement about Newton's laws of motion is correct? 9702/01/M/J/09/Q7
- A** The first law follows from the second law.  
**B** The third law follows from the second law.  
**C** Conservation of energy is a consequence of the third law.  
**D** Conservation of linear momentum is a consequence of the first law.

- 30 A lorry of mass  $20\,000\text{ kg}$  is travelling at  $20.0\text{ m s}^{-1}$ . A car of mass  $900\text{ kg}$  is travelling at  $30.0\text{ m s}^{-1}$  towards the lorry. 9702/01/M/J/07/Q11

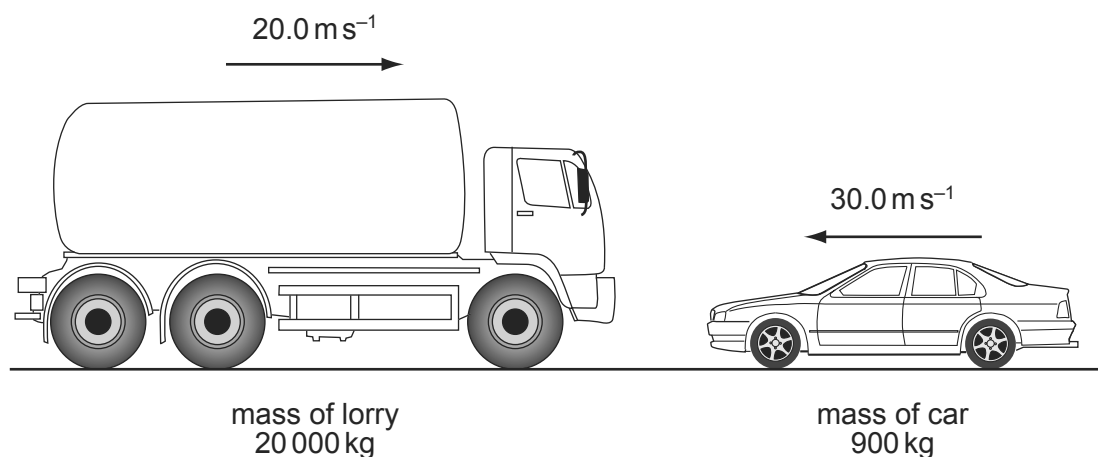

What is the magnitude of the total momentum?

- A**  $209\text{ kN s}$       **B**  $373\text{ kN s}$       **C**  $427\text{ kN s}$       **D**  $1045\text{ kN s}$
- 31 The diagram shows the masses and velocities of two trolleys about to collide. 9702/01/M/J/07/Q12



After the impact they move off together.

What is the total kinetic energy of the trolleys after the collision?

- A**  $1.3\text{ J}$       **B**  $12\text{ J}$       **C**  $18\text{ J}$       **D**  $19\text{ J}$
- 32 Which is a statement of the principle of conservation of momentum? 9702/01/M/J/08/Q9

- A** Momentum is the product of mass and velocity.  
**B** Momentum is conserved only in elastic collisions.  
**C** Momentum is conserved by all bodies in a collision.  
**D** Momentum is conserved providing no external forces act.

- 33 Which statement about a ball that strikes a tennis racket and rebounds is **always** correct? 9702/12/O/N/09/Q7

- A** Total kinetic energy of the ball is conserved.  
**B** Total kinetic energy of the system is conserved.  
**C** Total momentum of the ball is conserved.  
**D** Total momentum of the system is conserved.

- 34 Two equal masses X and Y are moving towards each other on a frictionless air track as shown. The masses make an elastic collision. 9702/01/M/J/08/Q10

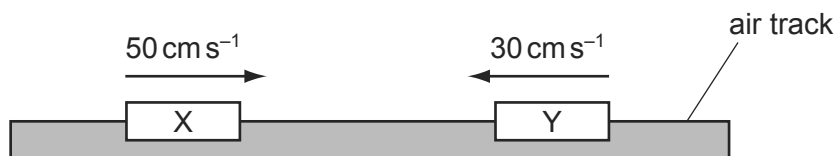

Which row gives possible velocities for the two masses after the collision?

	velocity of X	velocity of Y
<b>A</b>	zero	20 cm s <sup>-1</sup> to the right
<b>B</b>	10 cm s <sup>-1</sup> to the right	10 cm s <sup>-1</sup> to the right
<b>C</b>	20 cm s <sup>-1</sup> to the left	zero
<b>D</b>	30 cm s <sup>-1</sup> to the left	50 cm s <sup>-1</sup> to the right

- 35 A car of mass 750 kg has a horizontal driving force of 2.0 kN acting on it. It has a forward horizontal acceleration of 2.0 m s<sup>-2</sup>. 9702/01/O/N/08/Q11

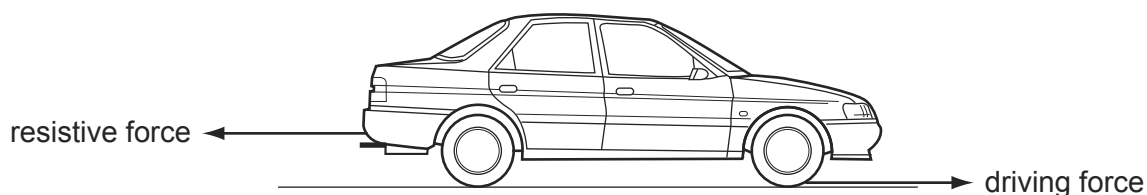

What is the resistive force acting horizontally?

- A** 0.5 kN      **B** 1.5 kN      **C** 2.0 kN      **D** 3.5 kN
- 36 Two spheres approach each other along the same straight line. Their speeds are  $u_1$  and  $u_2$  before collision, and  $v_1$  and  $v_2$  after collision, in the directions shown below. 9702/01/O/N/08/Q10

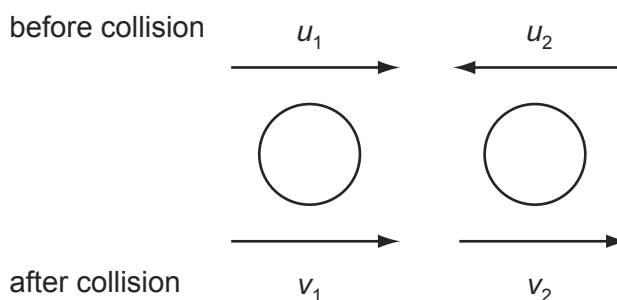

Which equation is correct if the collision is perfectly elastic?

- A**  $u_1 - u_2 = v_2 + v_1$   
**B**  $u_1 - u_2 = v_2 - v_1$   
**C**  $u_1 + u_2 = v_2 + v_1$   
**D**  $u_1 + u_2 = v_2 - v_1$

- 37 A ball falls vertically and bounces on the ground.

The following statements are about the forces acting while the ball is in contact with the ground.

Which statement is correct?

- A** The force that the ball exerts on the ground is always equal to the weight of the ball.
- B** The force that the ball exerts on the ground is always equal in magnitude and opposite in direction to the force the ground exerts on the ball.
- C** The force that the ball exerts on the ground is always less than the weight of the ball.
- D** The weight of the ball is always equal in magnitude and opposite in direction to the force that the ground exerts on the ball.
- 38 A tennis ball of mass 100 g is struck by a tennis racket. The velocity of the ball is changed as shown.

9702/01/M/J/09/Q9

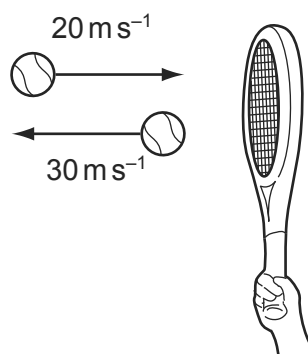

What is the magnitude of the change in momentum of the ball?

- A**  $1 \text{ kg m s}^{-1}$       **B**  $5 \text{ kg m s}^{-1}$       **C**  $1000 \text{ kg m s}^{-1}$       **D**  $5000 \text{ kg m s}^{-1}$
- 39 A stationary body explodes into two components of masses  $m$  and  $2m$ .

9702/01/M/J/09/Q10

The components gain kinetic energies  $X$  and  $Y$  respectively.

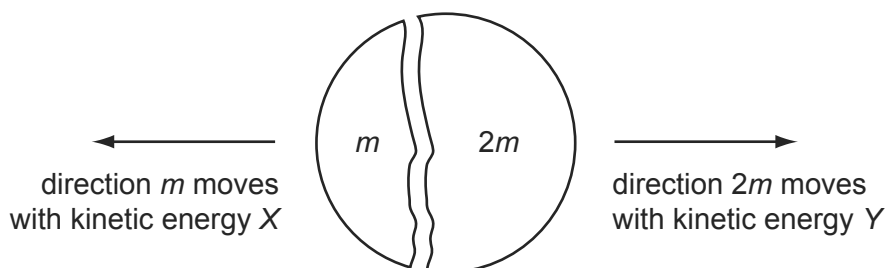

What is the value of the ratio  $\frac{X}{Y}$ ?

- A**  $\frac{1}{4}$       **B**  $\frac{1}{2}$       **C**  $\frac{2}{1}$       **D**  $\frac{4}{1}$

- 40 The diagram shows two spherical masses approaching each other head-on at an equal speed  $u$ . One has mass  $2m$  and the other has mass  $m$ . 9702/12/O/N/09/Q8



Which diagram, showing the situation after the collision, shows the result of an elastic collision?

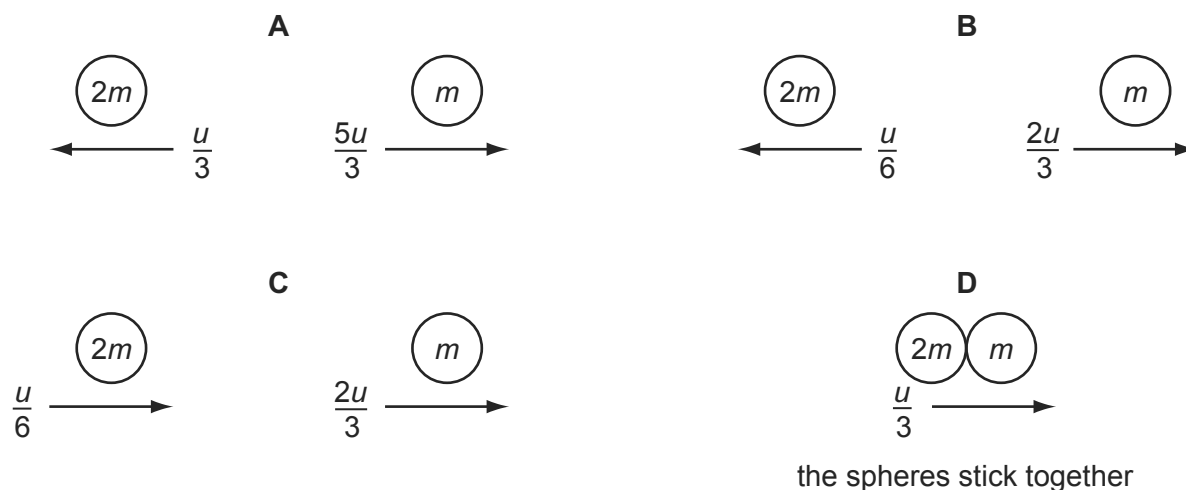

- 41 A supermarket trolley, total mass  $30\text{ kg}$ , is moving at  $3.0\text{ m s}^{-1}$ . A retarding force of  $60\text{ N}$  is applied to the trolley for  $0.50\text{ s}$  in the opposite direction to the trolley's initial velocity. 9702/12/O/N/09/Q9

What is the trolley's new velocity after the application of the force?

- A**  $1.0\text{ m s}^{-1}$       **B**  $1.5\text{ m s}^{-1}$       **C**  $2.0\text{ m s}^{-1}$       **D**  $2.8\text{ m s}^{-1}$
- 42 Two equal masses travel towards each other on a frictionless air track at speeds of  $60\text{ cm s}^{-1}$  and  $40\text{ cm s}^{-1}$ . They stick together on impact. 9702/11/M/J/10/Q10



What is the speed of the masses after impact?

- A**  $10\text{ cm s}^{-1}$       **B**  $20\text{ cm s}^{-1}$       **C**  $40\text{ cm s}^{-1}$       **D**  $50\text{ cm s}^{-1}$
- 43 A body, initially at rest, explodes into two masses  $M_1$  and  $M_2$  that move apart with speeds  $v_1$  and  $v_2$  respectively. 9702/11/O/N/10/Q11

What is the ratio  $\frac{v_1}{v_2}$ ?

- A**  $\frac{M_1}{M_2}$       **B**  $\frac{M_2}{M_1}$       **C**  $\sqrt{\frac{M_1}{M_2}}$       **D**  $\sqrt{\frac{M_2}{M_1}}$

- 44 The diagram shows two identical spheres X and Y.

9702/11/M/J/10/Q12

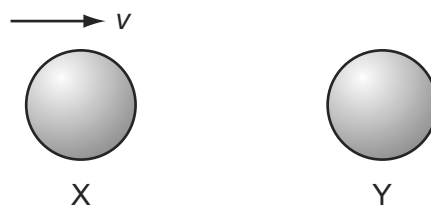

Initially, X moves with speed  $v$  directly towards Y. Y is stationary. The spheres collide elastically.

What happens?

	X	Y
<b>A</b>	moves with speed $\frac{1}{2}v$ to the right	moves with speed $\frac{1}{2}v$ to the right
<b>B</b>	moves with speed $v$ to the left	remains stationary
<b>C</b>	moves with speed $\frac{1}{2}v$ to the left	moves with speed $\frac{1}{2}v$ to the right
<b>D</b>	stops	moves with speed $v$ to the right

- 45 The diagram shows two identical spheres X and Y.

9702/13/M/J/10/Q9

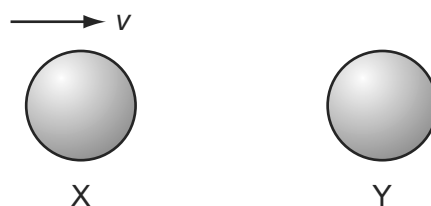

Initially, X moves with speed  $v$  directly towards Y. Y is stationary. The spheres collide elastically.

What happens?

	X	Y
<b>A</b>	moves with speed $\frac{1}{2}v$ to the right	moves with speed $\frac{1}{2}v$ to the right
<b>B</b>	moves with speed $v$ to the left	remains stationary
<b>C</b>	moves with speed $\frac{1}{2}v$ to the left	moves with speed $\frac{1}{2}v$ to the right
<b>D</b>	stops	moves with speed $v$ to the right

- 46 Which defines the weight of a body?

9702/12/O/N/10/Q10

- A** the amount of matter in the body
- B** the force of gravity on the body
- C** the number of particles in the body
- D** the product of the body's volume and density

- 47 The diagram shows two identical spheres X and Y.

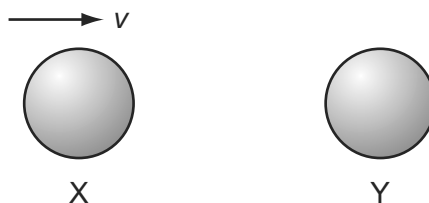

Initially, X moves with speed  $v$  directly towards Y. Y is stationary. The spheres collide elastically.

What happens?

	X	Y
<b>A</b>	moves with speed $\frac{1}{2}v$ to the right	moves with speed $\frac{1}{2}v$ to the right
<b>B</b>	moves with speed $v$ to the left	remains stationary
<b>C</b>	moves with speed $\frac{1}{2}v$ to the left	moves with speed $\frac{1}{2}v$ to the right
<b>D</b>	stops	moves with speed $v$ to the right

- 48 Two equal masses travel towards each other on a frictionless air track at speeds of  $60 \text{ cm s}^{-1}$  and  $40 \text{ cm s}^{-1}$ . They stick together on impact. 9702/12/M/J/10/Q11



What is the speed of the masses after impact?

- A**  $10 \text{ cm s}^{-1}$       **B**  $20 \text{ cm s}^{-1}$       **C**  $40 \text{ cm s}^{-1}$       **D**  $50 \text{ cm s}^{-1}$
- 49 Two equal masses travel towards each other on a frictionless air track at speeds of  $60 \text{ cm s}^{-1}$  and  $40 \text{ cm s}^{-1}$ . They stick together on impact. 9702/13/M/J/10/Q12



What is the speed of the masses after impact?

- A**  $10 \text{ cm s}^{-1}$       **B**  $20 \text{ cm s}^{-1}$       **C**  $40 \text{ cm s}^{-1}$       **D**  $50 \text{ cm s}^{-1}$
- 50 A molecule of mass  $m$  travelling horizontally with velocity  $u$  hits a vertical wall at right-angles to its velocity. It then rebounds horizontally with the same speed. 9702/11/M/J/11/Q10

What is its change in momentum?

- A** zero      **B**  $mu$       **C**  $-mu$       **D**  $-2mu$



- 51 The gravitational field strength on the surface of planet P is one tenth of that on the surface of planet Q. 9702/11/O/N/10/Q10

On the surface of P, a body has a mass of 1.0 kg and a weight of 1.0 N.

What are the mass and weight of the same body on the surface of planet Q?

	mass on Q/kg	weight on Q/N
<b>A</b>	1.0	0.1
<b>B</b>	1.0	10
<b>C</b>	10	10
<b>D</b>	10	100

- 52 Two experiments are carried out using two trolleys of equal mass. All moving parts of the trolleys are frictionless, as is the surface that the trolleys move over. In both experiments, trolley X moves towards trolley Y, which is initially stationary. 9702/11/O/N/10/Q12



After the collision in experiment 1, X is stationary and Y moves off to the right.

After the collision in experiment 2, the trolleys join and move off together.

What types of collision occur in these experiments?

	experiment 1	experiment 2
<b>A</b>	elastic	elastic
<b>B</b>	elastic	inelastic
<b>C</b>	inelastic	elastic
<b>D</b>	inelastic	inelastic

- 53 A body, initially at rest, explodes into two masses  $M_1$  and  $M_2$  that move apart with speeds  $v_1$  and  $v_2$  respectively. 9702/13/O/N/10/Q9

What is the ratio  $\frac{v_1}{v_2}$ ?

- A**  $\frac{M_1}{M_2}$       **B**  $\frac{M_2}{M_1}$       **C**  $\sqrt{\frac{M_1}{M_2}}$       **D**  $\sqrt{\frac{M_2}{M_1}}$

- 54 The momentum of an object changes from  $160 \text{ kg m s}^{-1}$  to  $240 \text{ kg m s}^{-1}$  in 2 s. 9702/12/M/J/11/Q11

What is the mean resultant force on the object during the change?

- A** 40 N      **B** 80 N      **C** 200 N      **D** 400 N

- 55 A particle of mass  $2m$  and velocity  $v$  strikes a wall.

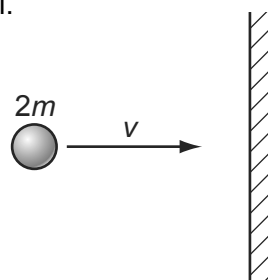

The particle rebounds along the same path after colliding with the wall. The collision is inelastic.

What is a possible change in the momentum of the ball during the collision?

- A**  $mv$                       **B**  $2mv$                       **C**  $3mv$                       **D**  $4mv$
- 56 The gravitational field strength on the surface of planet P is one tenth of that on the surface of planet Q. 9702/13/O/N/10/Q8

On the surface of P, a body has a mass of 1.0 kg and a weight of 1.0 N.

What are the mass and weight of the same body on the surface of planet Q?

	mass on Q/kg	weight on Q/N
<b>A</b>	1.0	0.1
<b>B</b>	1.0	10
<b>C</b>	10	10
<b>D</b>	10	100

- 57 Two experiments are carried out using two trolleys of equal mass. All moving parts of the trolleys are frictionless, as is the surface that the trolleys move over. In both experiments, trolley X moves towards trolley Y, which is initially stationary. 9702/13/O/N/10/Q10



After the collision in experiment 1, X is stationary and Y moves off to the right.

After the collision in experiment 2, the trolleys join and move off together.

What types of collision occur in these experiments?

	experiment 1	experiment 2
<b>A</b>	elastic	elastic
<b>B</b>	elastic	inelastic
<b>C</b>	inelastic	elastic
<b>D</b>	inelastic	inelastic

- 58 A body has a weight of 58.9 N when on the Earth. On the Moon, the acceleration of free fall is  $1.64 \text{ ms}^{-2}$ . 9702/11/M/J/11/Q8

What are the weight and the mass of the body when it is on the Moon?

	weight / N	mass / kg
<b>A</b>	9.85	1.00
<b>B</b>	9.85	6.00
<b>C</b>	58.9	1.00
<b>D</b>	58.9	6.00

- 59 A body of mass  $m$ , moving at velocity  $v$ , collides with a stationary body of the same mass and sticks to it. 9702/11/M/J/11/Q9

Which row describes the momentum and kinetic energy of the two bodies after the collision?

	momentum	kinetic energy
<b>A</b>	$mv$	$\frac{1}{4}mv^2$
<b>B</b>	$mv$	$\frac{1}{8}mv^2$
<b>C</b>	$2mv$	$\frac{1}{2}mv^2$
<b>D</b>	$2mv$	$mv^2$

- 60 A force  $F$  is applied to a freely moving object. At one instant of time, the object has velocity  $v$  and acceleration  $a$ . 9702/12/M/J/11/Q10

Which quantities **must** be in the same direction?

- A**  $a$  and  $v$  only  
**B**  $a$  and  $F$  only  
**C**  $v$  and  $F$  only  
**D**  $v$ ,  $F$  and  $a$
- 61 A car accelerates in a straight line. 9702/12/M/J/11/Q12

A graph of the momentum of the car is plotted against time.

What is evaluated by finding the gradient of the graph at a particular time?

- A** the acceleration of the car  
**B** the resultant force on the car  
**C** the kinetic energy of the car  
**D** the power supplied to the car

- 62 The diagram shows a particle P, travelling at speed  $v$ , about to collide with a stationary particle Q of the same mass. The collision is perfectly elastic. 9702/12/M/J/11/Q13

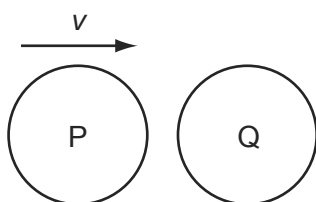

Which statement describes the motion of P and of Q immediately after the collision?

- A** P rebounds with speed  $\frac{1}{2}v$  and Q acquires speed  $\frac{1}{2}v$ .  
**B** P rebounds with speed  $v$  and Q remains stationary.  
**C** P and Q both travel in the same direction with speed  $\frac{1}{2}v$ .  
**D** P comes to a standstill and Q acquires speed  $v$ .
- 63 A molecule of mass  $m$  travelling horizontally with velocity  $u$  hits a vertical wall at right-angles to its velocity. It then rebounds horizontally with the same speed. 9702/13/M/J/11/Q9

What is its change in momentum?

- A** zero      **B**  $mu$       **C**  $-mu$       **D**  $-2mu$
- 64 A body of mass  $m$ , moving at velocity  $v$ , collides with a stationary body of the same mass and sticks to it.

Which row describes the momentum and kinetic energy of the two bodies after the collision? 9702/13/M/J/11/Q10

	momentum	kinetic energy
<b>A</b>	$mv$	$\frac{1}{4}mv^2$
<b>B</b>	$mv$	$\frac{1}{8}mv^2$
<b>C</b>	$2mv$	$\frac{1}{2}mv^2$
<b>D</b>	$2mv$	$mv^2$

- 65 A body has a weight of 58.9 N when on the Earth. On the Moon, the acceleration of free fall is  $1.64 \text{ m s}^{-2}$ . 9702/13/M/J/11/Q6

What are the weight and the mass of the body when it is on the Moon?

	weight/N	mass/kg
<b>A</b>	9.85	1.00
<b>B</b>	9.85	6.00
<b>C</b>	58.9	1.00
<b>D</b>	58.9	6.00

- 66 What is the **definition** of the force on a body?
- A the mass of the body multiplied by its acceleration
  - B the power input to the body divided by its velocity
  - C the rate of change of momentum of the body
  - D the work done on the body divided by its displacement

- 67 A car accelerates from rest. The graph shows the momentum of the car plotted against time.

9702/11/O/N/11/Q11

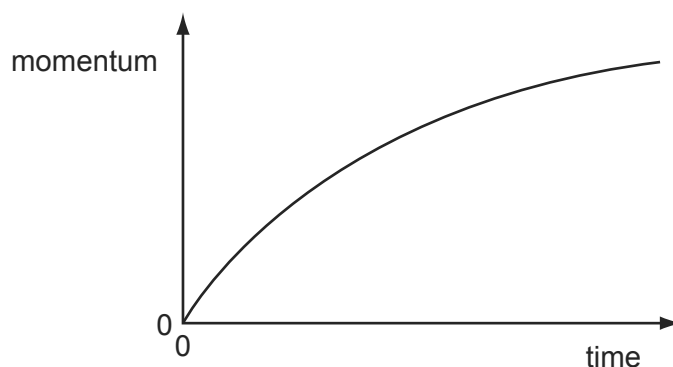

What is the meaning of the gradient of the graph at a particular time?

- A the resultant force on the car
  - B the velocity of the car
  - C the kinetic energy of the car
  - D the rate of change of kinetic energy of the car
- 68 An ice-hockey puck slides along a horizontal, frictionless ice-rink surface. It collides inelastically with a wall at right angles to its path, and then rebounds along its original path.

9702/11/O/N/11/Q12

Which graph shows the variation with time  $t$  of the momentum  $p$  of the puck?

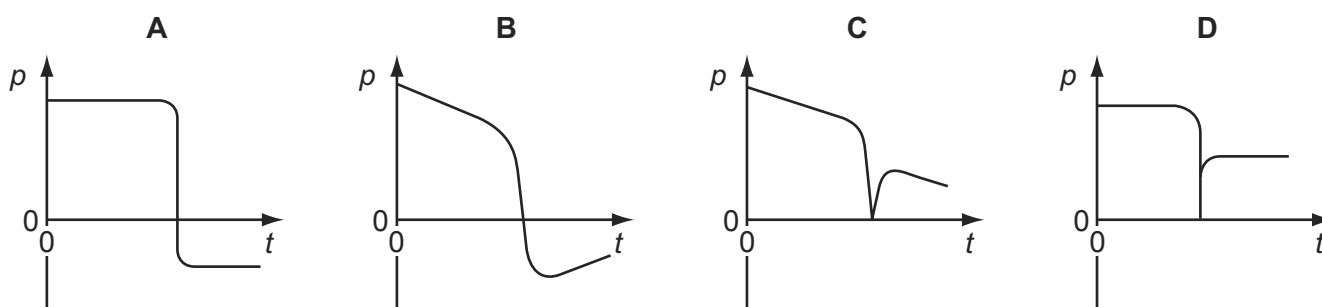

- 69 An object of mass 20 kg is travelling at a constant speed of  $6.0 \text{ m s}^{-1}$ .

9702/12/O/N/11/Q11

It collides with an object of mass 12 kg travelling at a constant speed of  $15 \text{ m s}^{-1}$  in the opposite direction. The objects stick together.

What is the speed of the objects immediately after the collision?

- A  $1.9 \text{ m s}^{-1}$
- B  $9.0 \text{ m s}^{-1}$
- C  $9.4 \text{ m s}^{-1}$
- D  $21 \text{ m s}^{-1}$

- 70 A golf ball is hit by a club. The graph shows the variation with time of the force exerted on the ball by the club.

9702/12/O/N/11/Q9

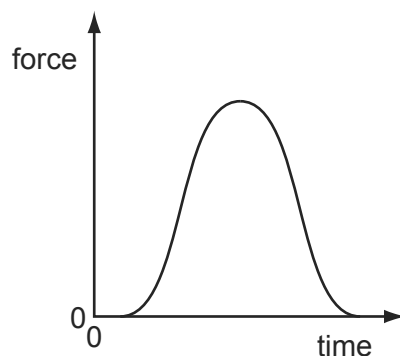

Which quantity, for the time of contact, **cannot** be found from the graph?

- A** the average force on the ball  
**B** the change in momentum of the ball  
**C** the contact time between the ball and the club  
**D** the maximum acceleration of the ball
- 71 A group of students investigating the principle of conservation of momentum use a small truck travelling over a frictionless surface.

9702/12/O/N/11/Q10

Sand is dropped into the truck as it passes X. At Y, a trapdoor in the bottom of the truck opens and the sand falls out.



How does the velocity of the truck change when the sand is added to the truck at X and then leaves the truck at Y?

	at X	at Y
<b>A</b>	decreases	increases
<b>B</b>	decreases	stays the same
<b>C</b>	stays the same	increases
<b>D</b>	stays the same	stays the same

- 72 What is the **definition** of the force on a body?
- A** the mass of the body multiplied by its acceleration  
**B** the power input to the body divided by its velocity  
**C** the rate of change of momentum of the body  
**D** the work done on the body divided by its displacement

- 73 An ice-hockey puck slides along a horizontal, frictionless ice-rink surface. It collides inelastically with a wall at right angles to its path, and then rebounds along its original path. 9702/13/O/N/11/Q10

Which graph shows the variation with time  $t$  of the momentum  $p$  of the puck?

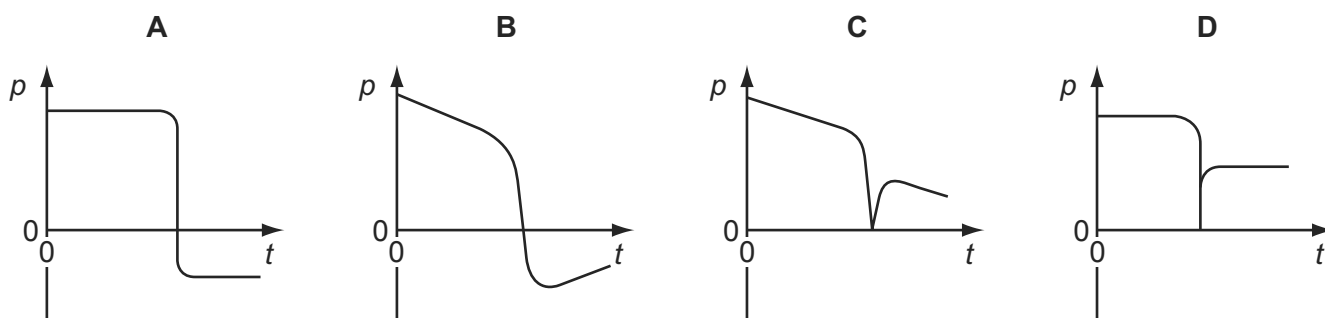

- 74 A car accelerates from rest. The graph shows the momentum of the car plotted against time. 9702/13/O/N/11/Q12

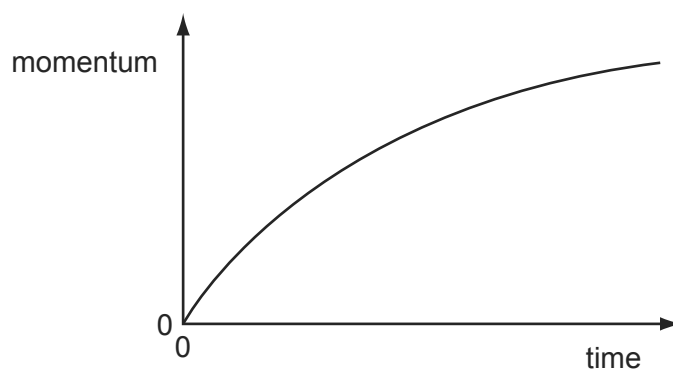

What is the meaning of the gradient of the graph at a particular time?

- A** the resultant force on the car  
**B** the velocity of the car  
**C** the kinetic energy of the car  
**D** the rate of change of kinetic energy of the car
- 75 Which row correctly states whether momentum and kinetic energy are conserved in an inelastic collision in which there are no external forces? 9702/12/M/J/12/Q11

	momentum	kinetic energy
<b>A</b>	conserved	conserved
<b>B</b>	conserved	not conserved
<b>C</b>	not conserved	conserved
<b>D</b>	not conserved	not conserved

- 76 Two spheres approach each other along the same straight line. Their speeds are  $u_1$  and  $u_2$  before collision. After the collision, the spheres separate with speeds  $v_1$  and  $v_2$  in the directions shown below.

9702/12/M/J/12/Q12



Which equation must be correct if the collision is perfectly elastic?

- A**  $u_1 - u_2 = v_2 + v_1$
- B**  $u_1 - u_2 = v_2 - v_1$
- C**  $u_1 + u_2 = v_2 + v_1$
- D**  $u_1 + u_2 = v_2 - v_1$
- 77 Each option gives a correct word equation involving force.

9702/12/M/J/12/Q10

Which option gives the definition of force?

- A** force = energy divided by displacement
- B** force = mass  $\times$  acceleration
- C** force = pressure  $\times$  area
- D** force = rate of change of momentum
- 78 Two similar spheres, each of mass  $m$  and travelling with speed  $v$ , are moving towards each other.

9702/12/M/J/12/Q11

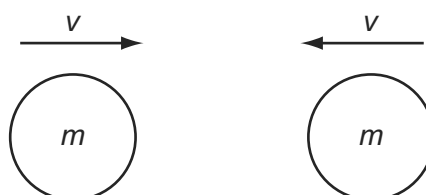

The spheres have a head-on elastic collision.

Which statement is correct?

- A** The spheres stick together on impact.
- B** The total kinetic energy after impact is  $mv^2$ .
- C** The total kinetic energy before impact is zero.
- D** The total momentum before impact is  $2mv$ .



- 79 Each option gives a correct word equation involving force.

Which option gives the definition of force?

- A force = energy divided by displacement
- B force = mass  $\times$  acceleration
- C force = pressure  $\times$  area
- D force = rate of change of momentum

- 80 Two similar spheres, each of mass  $m$  and travelling with speed  $v$ , are moving towards each other.

9702/13/M/J/12/Q12

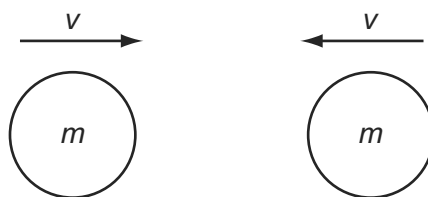

The spheres have a head-on elastic collision.

Which statement is correct?

- A The spheres stick together on impact.
- B The total kinetic energy after impact is  $mv^2$ .
- C The total kinetic energy before impact is zero.
- D The total momentum before impact is  $2mv$ .

- 81 The velocity of a car changes as shown.

9702/12/O/N/12/Q11

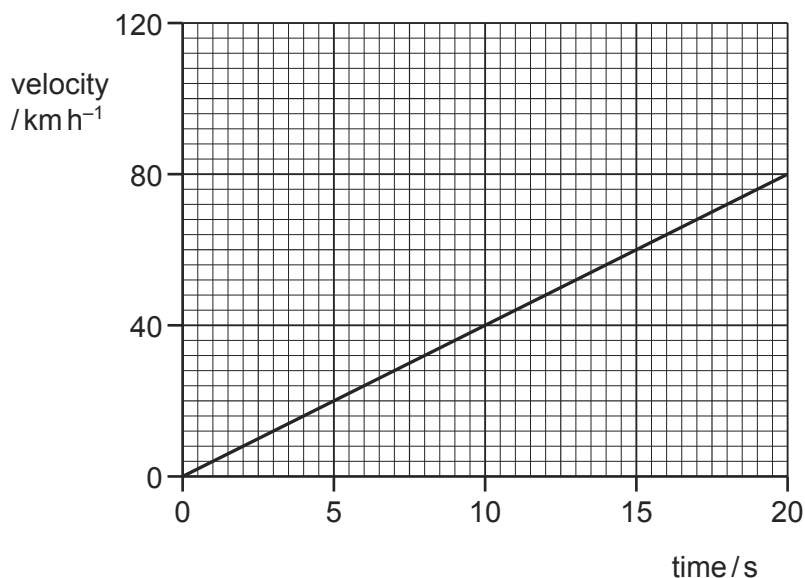

What is the acceleration of the car?

- A  $1.1 \text{ ms}^{-2}$
- B  $4.0 \text{ ms}^{-2}$
- C  $224 \text{ ms}^{-2}$
- D  $800 \text{ ms}^{-2}$

- 82 Two identical, perfectly elastic spheres have the same mass  $m$ . They travel towards each other with the same speed  $v$  along a horizontal frictionless surface.

9702/12/O/N/12/Q13

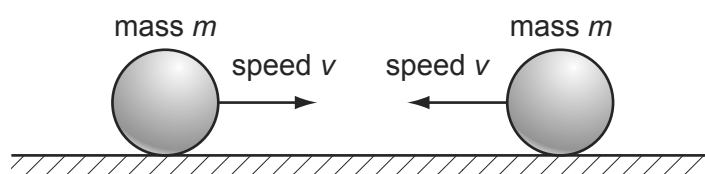

Which statement about the sum of the kinetic energies of the spheres is correct?

- A** The sum of their kinetic energies before impact is zero.  
**B** The sum of their kinetic energies before impact is  $\frac{1}{2}mv^2$ .  
**C** The sum of their kinetic energies after impact is zero.  
**D** The sum of their kinetic energies after impact is  $mv^2$ .
- 83 A 1.2 kg mass is supported by a person's hand and two newton-meters as shown.

9702/12/O/N/12/Q14

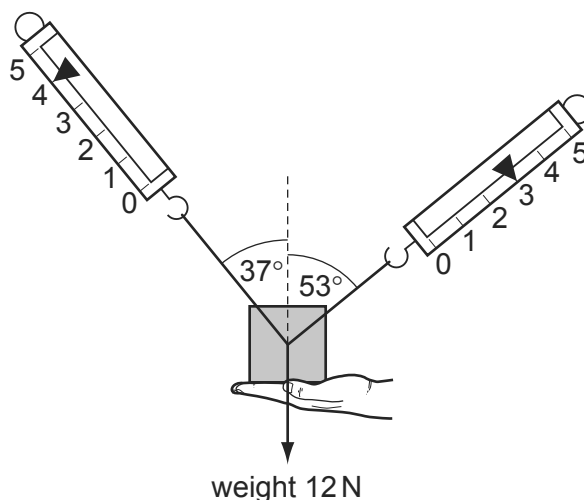

When the person's hand is removed, what is the initial vertical acceleration of the mass?

- A**  $0.6 \text{ ms}^{-2}$       **B**  $2 \text{ ms}^{-2}$       **C**  $4 \text{ ms}^{-2}$       **D**  $6 \text{ ms}^{-2}$
- 84 A ball of mass 0.5 kg is thrown against a wall at a speed of  $12 \text{ ms}^{-1}$ . It bounces back with a speed of  $8 \text{ ms}^{-1}$ . The collision lasts for 0.10 s.

9702/12/O/N/12/Q12

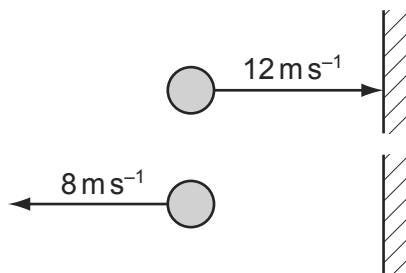

What is the average force on the ball due to the collision?

- A** 0.2 N      **B** 1 N      **C** 20 N      **D** 100 N

85 A lorry of mass 20 000 kg has a constant resultant force  $F$  acting on it.

It accelerates from  $6.0 \text{ m s}^{-1}$  to  $30.0 \text{ m s}^{-1}$  in a time of 300 s.

What is the change in momentum of the lorry and the value of  $F$ ?

	change in momentum / N s	force $F$ / N
<b>A</b>	48 000	160
<b>B</b>	480 000	1600
<b>C</b>	600 000	2000
<b>D</b>	600 000	20 000

86 A stationary body floats in water.

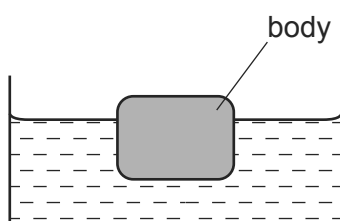

Which statement about the forces acting on the body is correct?

- A** The gravitational force is equal to the viscous force.
- B** The gravitational force is greater than the upthrust.
- C** The upthrust is zero.
- D** The viscous force is zero.

87 An object travelling with velocity  $v$  strikes a wall and rebounds as shown.

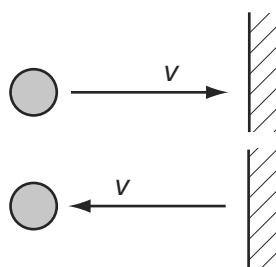

Which property of the object is **not** conserved?

- A** kinetic energy
- B** mass
- C** momentum
- D** speed

- 88 A particle X has speed  $v$  and collides with a stationary identical particle Y. The collision is perfectly elastic.

9702/11/O/N/12/Q12

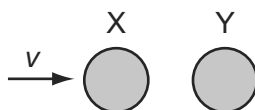

What are the speed and direction of motion of each of the two particles after the collision?

	X	Y
<b>A</b>	stationary	$v$ to the right
<b>B</b>	$\frac{v}{2}$ to the right	$\frac{v}{2}$ to the right
<b>C</b>	$\frac{v}{2}$ to the left	$\frac{v}{2}$ to the right
<b>D</b>	$v$ to the left	stationary

- 89 A mass of 2.0 kg rests on a frictionless surface. It is attached to a 1.0 kg mass by a light, thin string which passes over a frictionless pulley. The 1.0 kg mass is released and it accelerates downwards.

9702/11/O/N/12/Q13

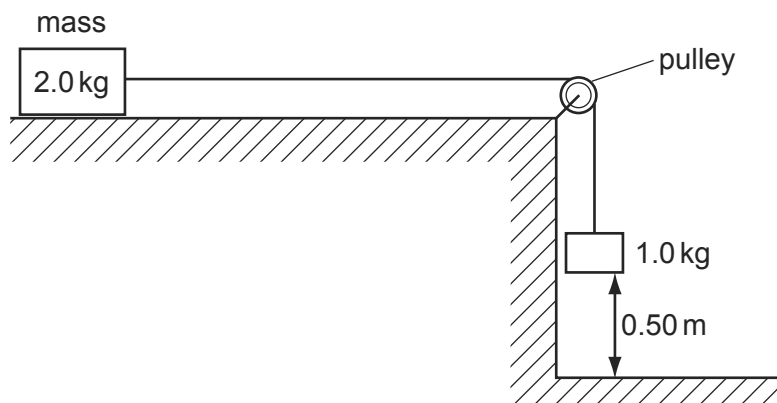

What is the speed of the 2.0 kg mass as the 1.0 kg mass hits the floor, having fallen a distance of 0.50 m?

- A**  $1.8 \text{ ms}^{-1}$       **B**  $2.2 \text{ ms}^{-1}$       **C**  $3.1 \text{ ms}^{-1}$       **D**  $9.8 \text{ ms}^{-1}$

- 90 A lead pellet is shot vertically upwards into a clay block that is stationary at the moment of impact but is able to rise freely after impact.

9702/11/O/N/12/Q14

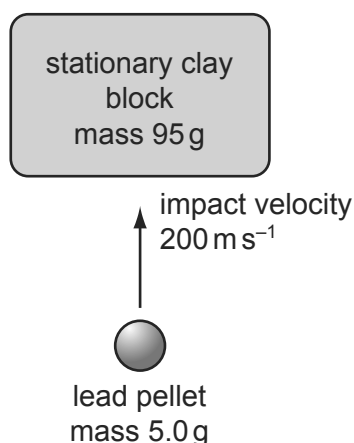

The pellet hits the block with an initial velocity of 200 m s<sup>-1</sup>. It embeds itself in the block and does not emerge.

How high above its initial position will the block rise?  
(Mass of pellet = 5.0 g; mass of clay block = 95 g.)

- A** 5.1 m      **B** 5.6 m      **C** 10 m      **D** 2000 m
- 91 The diagram shows two spherical masses approaching each other head-on at an equal speed  $u$ . One is of mass  $m$  and the other of mass  $2m$ .

9702/13/O/N/12/Q11



Which diagram, showing the situation after the collision, is **not** consistent with the principle of conservation of momentum?

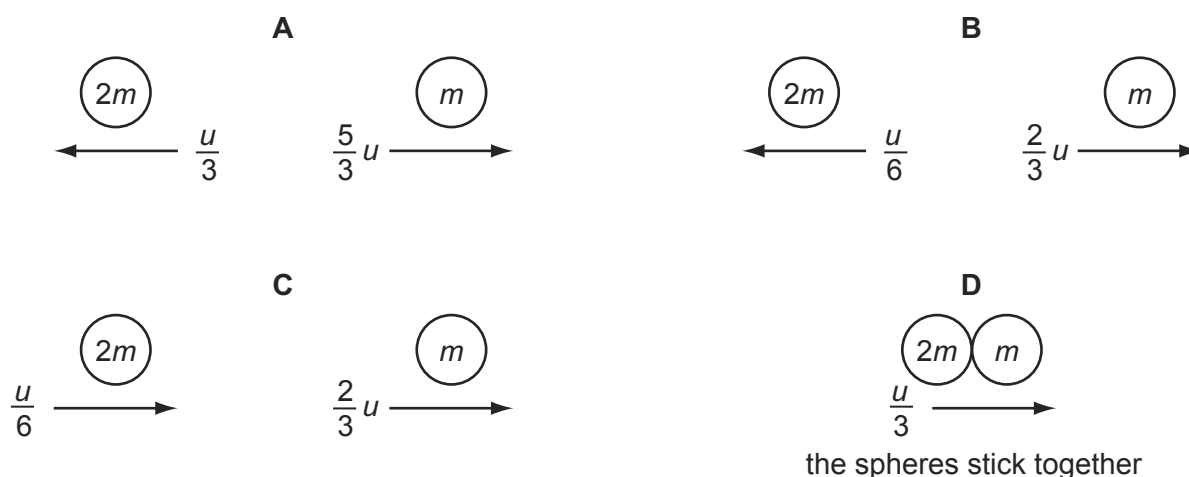

- 92 A molecule of mass  $m$  travelling at speed  $v$  hits a wall in a direction perpendicular to the wall. The collision is elastic. 9702/13/O/N/12/Q12

What are the changes in the kinetic energy and in the momentum of the molecule caused by the collision?

	change in momentum	change in kinetic energy
<b>A</b>	0	0
<b>B</b>	0	$mv^2$
<b>C</b>	$2mv$	0
<b>D</b>	$mv^2$	0

- 93 The IKAROS satellite has mass 320 kg and moves through space using a solar sail of area  $20\text{ m}^2$ . The average solar wind pressure is  $1.0 \times 10^{-5}\text{ N m}^{-2}$ . 9702/13/O/N/12/Q13

What is the acceleration of the satellite caused by the solar wind?

- A**  $3.1 \times 10^{-8}\text{ m s}^{-2}$   
**B**  $6.3 \times 10^{-7}\text{ m s}^{-2}$   
**C**  $3.2 \times 10^{-3}\text{ m s}^{-2}$   
**D**  $6.4 \times 10^{-2}\text{ m s}^{-2}$
- 94 The graph shows the momentum of a cyclist over a period of 8.0 s. 9702/13/O/N/12/Q14

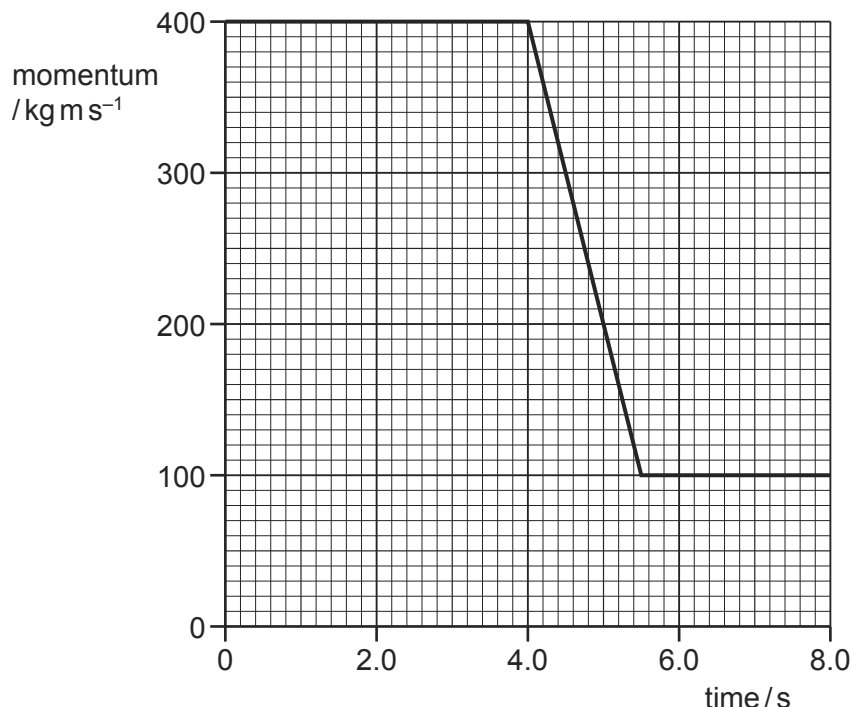

At time 4.0 s, she applies the brakes.

What is the resultant force on the cyclist during the period when the brakes are applied?

- A** 55 N      **B** 200 N      **C** 270 N      **D** 450 N

95 Which of the following is a statement of the principle of conservation of momentum? 9702/11/M/J/13/Q10

- A In an elastic collision momentum is constant.
- B Momentum is the product of mass and velocity.
- C The force acting on a body is proportional to its rate of change of momentum.
- D The momentum of an isolated system is constant.

96 A stationary nucleus has nucleon number  $A$ .

9702/13/M/J/13/Q10

The nucleus decays by emitting a proton with speed  $v$  to form a new nucleus with speed  $u$ . The new nucleus and the proton move away from one another in opposite directions.

Which equation gives  $v$  in terms of  $A$  and  $u$ ?

- A  $v = \left(\frac{A}{4} - 1\right)u$
- B  $v = (A - 1)u$
- C  $v = Au$
- D  $v = (A + 1)u$

97 A strong wind of speed  $33 \text{ m s}^{-1}$  blows against a wall. The density of the air is  $1.2 \text{ kg m}^{-3}$ . The wall has an area of  $12 \text{ m}^2$  at right angles to the wind velocity. The air has its speed reduced to zero when it hits the wall.

9702/12/M/J/13/Q9

What is the approximate force exerted by the air on the wall?

- A 330 N
- B 400 N
- C 480 N
- D 16000 N

98 Two spheres travel along the same line with velocities  $u_1$  and  $u_2$ . They collide and after collision their velocities are  $v_1$  and  $v_2$ .

9702/13/M/J/13/Q11



Which collision is **not** elastic?

	$u_1/\text{ms}^{-1}$	$u_2/\text{ms}^{-1}$	$v_1/\text{ms}^{-1}$	$v_2/\text{ms}^{-1}$
A	2	-5	-5	-2
B	3	-3	0	6
C	3	-2	1	6
D	5	2	3	6

- 99 A 2.0 kg mass travelling at  $3.0 \text{ m s}^{-1}$  on a frictionless surface collides head-on with a stationary 1.0 kg mass. The masses stick together on impact. 9702/11/M/J/13/Q11

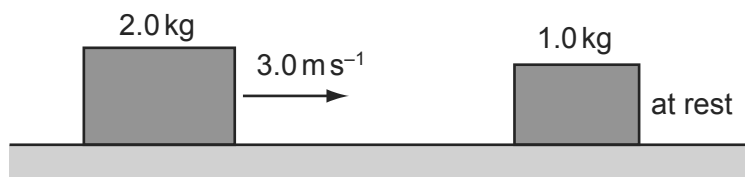

How much kinetic energy is lost on impact?

- A** zero      **B** 2.0 J      **C** 2.4 J      **D** 3.0 J
- 100 Two bodies travelling in a straight line collide in a perfectly elastic collision. Which of the following statements **must** be correct? 9702/12/M/J/13/Q10
- A** The initial speed of one body will be the same as the final speed of the other body.
- B** The relative speed of approach between the two bodies equals their relative speed of separation.
- C** The total momentum is conserved but the total kinetic energy will be reduced.
- D** One of the bodies will be stationary at one instant.
- 101 A moving thorium nucleus  ${}_{90}^{230}\text{Th}$  spontaneously emits an  $\alpha$ -particle. The nucleus formed is a radium nucleus  ${}_{88}^{226}\text{Ra}$ , as shown. 9702/13/O/N/13/Q10

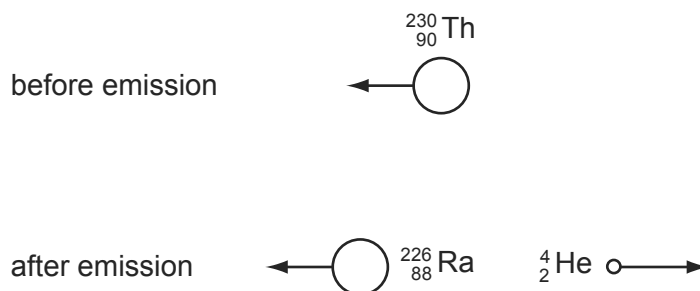

Which statement is correct?

- A** The kinetic energy of the  $\alpha$ -particle equals the kinetic energy of the radium nucleus.
- B** The momentum of the  $\alpha$ -particle equals the momentum of the radium nucleus.
- C** The total momentum before the emission equals the total momentum after the emission.
- D** The velocity of the  $\alpha$ -particle equals the velocity of the radium nucleus.



- 102 A lead pellet of mass 10.0 g is shot horizontally into a stationary wooden block of mass 100 g. The pellet hits the block with an impact velocity of  $250 \text{ m s}^{-1}$ . It embeds itself in the block and it does not emerge.

9702/13/O/N/13/Q13

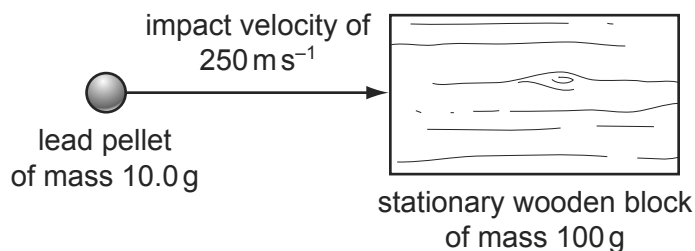

What will be the speed of the block immediately after the pellet is embedded?

- A**  $23 \text{ m s}^{-1}$       **B**  $25 \text{ m s}^{-1}$       **C**  $75 \text{ m s}^{-1}$       **D**  $79 \text{ m s}^{-1}$
- 103 A beam of  $\alpha$ -particles collides with a lead sheet. Each  $\alpha$ -particle in the beam has a mass of  $6.6 \times 10^{-27} \text{ kg}$  and a speed of  $1.5 \times 10^7 \text{ m s}^{-1}$ .

9702/11/O/N/13/Q11

$5.0 \times 10^4$   $\alpha$ -particles per second collide with an area of  $1.0 \text{ cm}^2$  of lead. Almost all of the  $\alpha$ -particles are absorbed by the lead so that they have zero speed after collision.

What is an estimate of the average pressure exerted on the lead by the  $\alpha$ -particles?

- A**  $5.0 \times 10^{-15} \text{ Pa}$   
**B**  $5.0 \times 10^{-13} \text{ Pa}$   
**C**  $5.0 \times 10^{-11} \text{ Pa}$   
**D**  $5.0 \times 10^{-9} \text{ Pa}$
- 104 An isolated system consists of two bodies on which no external forces act. The two bodies collide with each other and stick together on impact.

9702/13/O/N/13/Q11

Which row correctly compares the total kinetic energy and the total momentum of the bodies before and after the collision?

	total kinetic energy before and after the collision	total momentum before and after the collision
<b>A</b>	different	different
<b>B</b>	different	the same
<b>C</b>	the same	different
<b>D</b>	the same	the same

- 105 An object of mass  $4.0\text{ kg}$  moving with a speed of  $3.0\text{ m s}^{-1}$  strikes a stationary object in an inelastic collision. 9702/11/M/J/14/Q9

Which statement is correct?

- A** After collision, the total kinetic energy is  $18\text{ J}$ .
- B** After collision, the total kinetic energy is less than  $18\text{ J}$ .
- C** Before collision, the total kinetic energy is  $12\text{ J}$ .
- D** Before collision, the total kinetic energy is less than  $12\text{ J}$ .

- 106 The graph shows how the momentum of a motorcycle changes with time. 9702/11/M/J/14/Q10

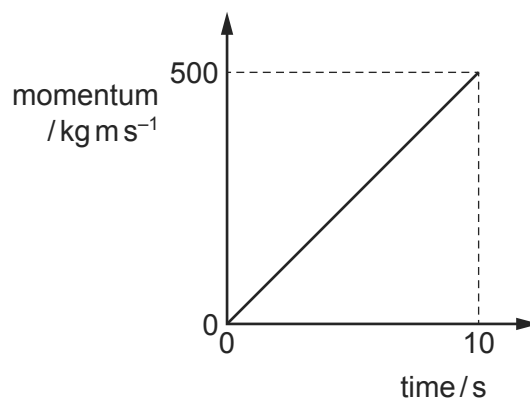

What is the resultant force on the motorcycle?

- A**  $50\text{ N}$
  - B**  $500\text{ N}$
  - C**  $2500\text{ N}$
  - D**  $5000\text{ N}$
- 107 Two train carriages each of mass  $5000\text{ kg}$  roll toward one another on a level track. One is travelling at  $2.00\text{ m s}^{-1}$  and the other at  $1.00\text{ m s}^{-1}$ , as shown. 9702/12/M/J/14/Q7

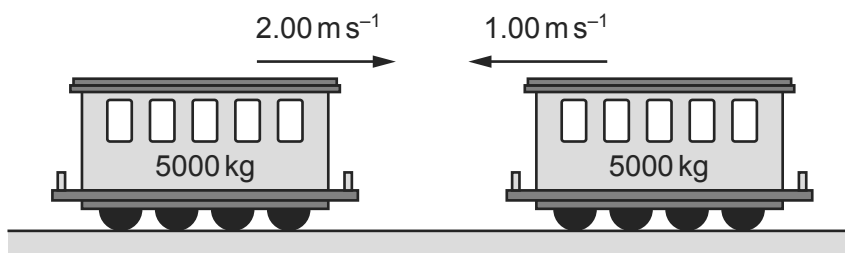

They collide and join together.

What is the kinetic energy lost during the collision?

- A**  $1250\text{ J}$
- B**  $7500\text{ J}$
- C**  $11250\text{ J}$
- D**  $12500\text{ J}$

108 A resultant force causes a body to accelerate.

9702/12/M/J/14/Q8

What is equal to the resultant force?

- A the acceleration of the body per unit mass
- B the change in kinetic energy of the body per unit time
- C the change in momentum of the body per unit time
- D the change in velocity of the body per unit time

109 A ship of mass  $8.4 \times 10^7$  kg is approaching a harbour with speed  $16.4 \text{ ms}^{-1}$ . By using reverse thrust it can maintain a constant total stopping force of 920 000 N.

9702/12/M/J/14/Q9

How long will it take to stop?

- A 15 seconds
- B 150 seconds
- C 25 minutes
- D 250 minutes

110 A tractor of mass 1000 kg is connected by a tow-bar to a trailer of mass 1000 kg. The total resistance to motion has a constant value of 4000 N. One quarter of this resistance acts on the trailer.

9702/12/M/J/14/Q10

When the tractor and trailer are moving along horizontal ground at a constant speed of  $6 \text{ ms}^{-1}$ , what is the force exerted on the tractor by the tow-bar?

- A 0 N
- B 1000 N
- C 3000 N
- D 4000 N

111 A tennis ball is dropped onto a table and bounces back up. The table exerts a force  $F$  on the ball.

Which graph best shows the variation with time  $t$  of the force  $F$  while the ball is in contact with the table?

9702/13/M/J/14/Q10

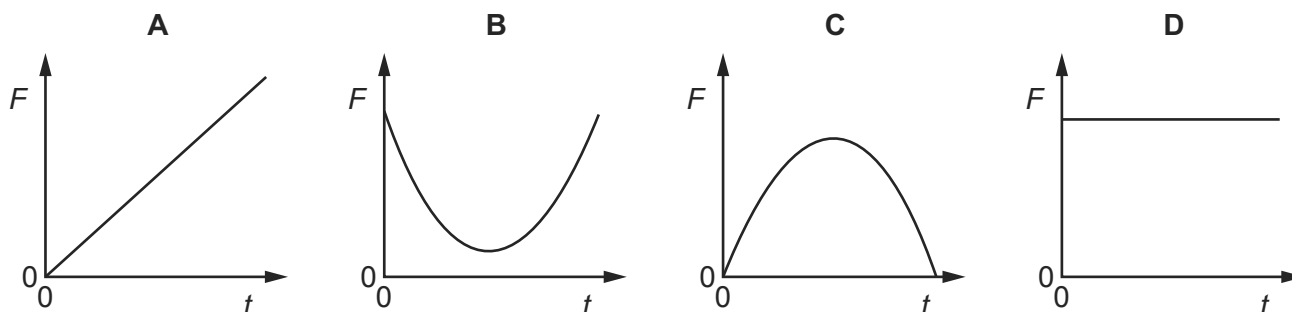

- 112 A resultant force of 10 N acts on a body for a time of 2.0 s.

9702/13/M/J/14/Q11

Which graph could show the variation with time  $t$  of the momentum  $p$  of the body?

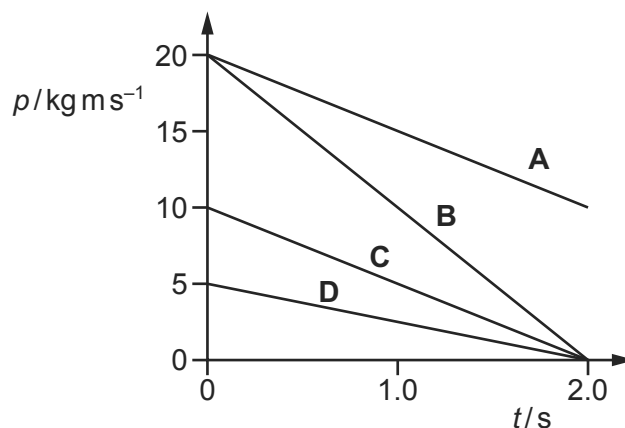

- 113 A stationary body explodes into two components of masses  $m$  and  $2m$ .

9702/13/M/J/14/Q12

The components gain kinetic energies  $X$  and  $Y$  respectively.

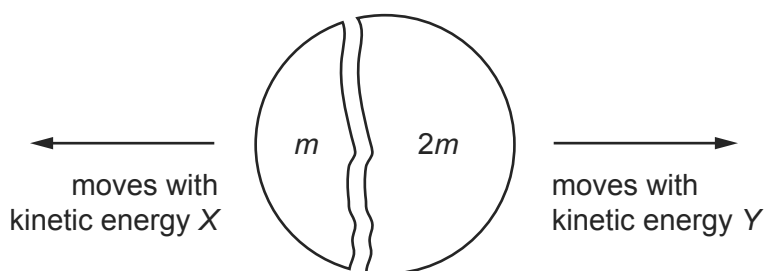

What is the value of the ratio  $\frac{X}{Y}$ ?

**A**  $\frac{1}{4}$

**B**  $\frac{1}{2}$

**C**  $\frac{2}{1}$

**D**  $\frac{4}{1}$

- 114 A body experiences a varying resultant force that causes its momentum to vary, as shown in the graph.

9702/13/O/N/14/Q10

At which point does the resultant force have the largest value?

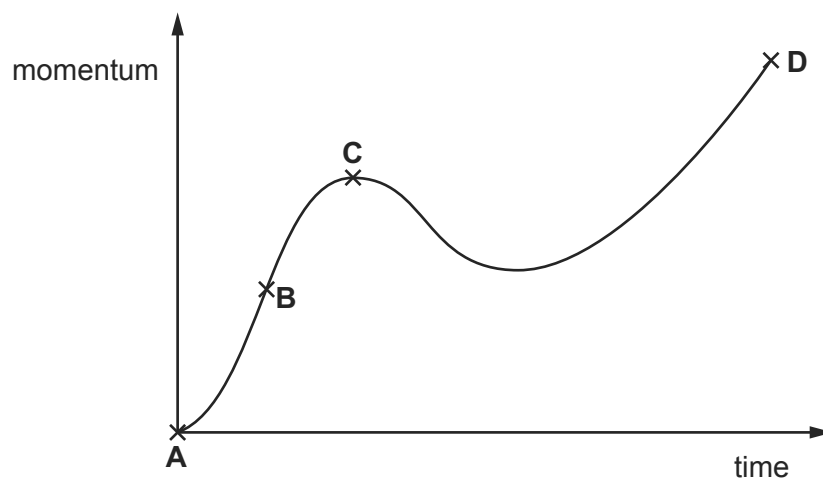

- 115 A golf ball of mass  $m$  is dropped onto a hard surface from a height  $h_1$  and rebounds to a height  $h_2$ . 9702/13/O/N/14/Q11

The momentum of the golf ball just as it reaches the surface is different from its momentum just as it leaves the surface.

What is the total change in the momentum of the golf ball between these two instants? (Ignore air resistance.)

- A**  $m\sqrt{2gh_1} - m\sqrt{2gh_2}$   
**B**  $m\sqrt{2gh_1} + m\sqrt{2gh_2}$   
**C**  $m\sqrt{2g(h_1 - h_2)}$   
**D**  $m\sqrt{2g(h_1 + h_2)}$

- 116 The diagram shows a particle X, with kinetic energy  $E_k$ , about to collide with a stationary particle Y. Both particles have the same mass. 9702/13/O/N/14/Q16



After colliding, X and Y travel onwards together as a single larger particle.

How much kinetic energy is lost in the collision?

- A** 0                      **B**  $\frac{E_k}{4}$                       **C**  $\frac{E_k}{2}$                       **D**  $\frac{3E_k}{4}$

- 117 Two railway trucks of masses  $m$  and  $3m$  move towards each other in opposite directions with speeds  $2v$  and  $v$  respectively. These trucks collide and stick together. 9702/11/O/N/14/Q9

What is the speed of the trucks after the collision?

- A**  $\frac{v}{4}$                       **B**  $\frac{v}{2}$                       **C**  $v$                       **D**  $\frac{5v}{4}$

- 118 What is the principle of conservation of momentum? 9702/11/O/N/14/Q7

- A** Force is equal to the rate of change of momentum.  
**B** Momentum is the product of mass and velocity.  
**C** The total momentum of a system remains constant provided no external force acts on it.  
**D** The total momentum of two bodies after collision is equal to their total momentum before collision.

- 119 Water is pumped through a hose-pipe at a rate of 90 kg per minute. It emerges from the hose-pipe horizontally with a speed of  $20 \text{ m s}^{-1}$ . 9702/11/O/N/14/Q8

Which force is required from a person holding the hose-pipe to prevent it moving backwards?

- A** 30 N                      **B** 270 N                      **C** 1800 N                      **D** 10 800 N

- 120 Which of the following is a statement of the principle of conservation of momentum?

9702/13/M/J/15/Q10

- A** Momentum is the product of mass and velocity.  
**B** In an elastic collision, momentum is constant.  
**C** The momentum of an isolated system is constant.  
**D** The force acting on a body is proportional to its rate of change of momentum.

- 121 A wooden block is freely supported on brackets at a height of 4.0 m above the ground, as shown.

9702/13/M/J/15/Q13

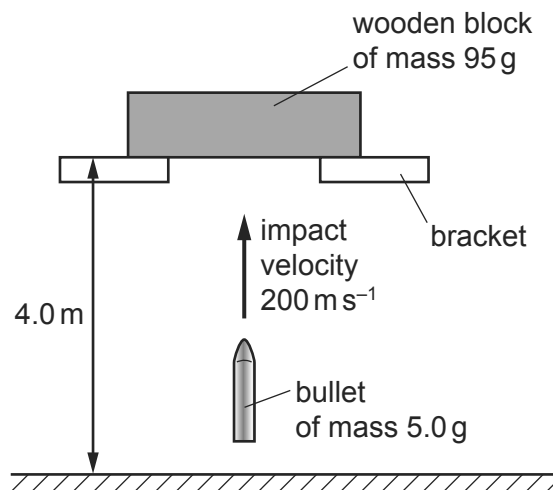

A bullet of mass 5.0 g is shot vertically upwards into the wooden block of mass 95 g. It embeds itself in the block. The impact causes the block to rise above its supporting brackets.

The bullet hits the block with a velocity of  $200 \text{ m s}^{-1}$ . How far above the ground will the block be at the maximum height of its path?

- A** 5.1 m                      **B** 5.6 m                      **C** 9.1 m                      **D** 9.6 m

- 122 A moving object strikes a stationary object. The collision is inelastic. The objects move off together.

9702/13/M/J/15/Q11

Which row shows the possible values of total momentum and total kinetic energy for the system before and after the collision?

	total momentum before collision / $\text{kg ms}^{-1}$	total momentum after collision / $\text{kg ms}^{-1}$	total kinetic energy before collision / J	total kinetic energy after collision / J
<b>A</b>	6	2	90	30
<b>B</b>	6	6	30	90
<b>C</b>	6	6	90	30
<b>D</b>	6	6	90	90

- 123 Two balls X and Y are moving towards each other with speeds of  $5 \text{ ms}^{-1}$  and  $15 \text{ ms}^{-1}$  respectively.

9702/13/M/J/15/Q12

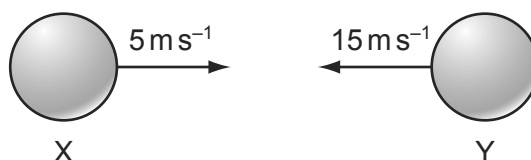

They make a perfectly elastic head-on collision and ball Y moves to the right with a speed of  $7 \text{ ms}^{-1}$ .

What is the speed and direction of ball X after the collision?

- A**  $3 \text{ ms}^{-1}$  to the left  
**B**  $13 \text{ ms}^{-1}$  to the left  
**C**  $3 \text{ ms}^{-1}$  to the right  
**D**  $13 \text{ ms}^{-1}$  to the right
- 124 A firework rocket is fired vertically upwards. The fuel burns and produces a constant upwards force on the rocket. After 5 seconds there is no fuel left. Air resistance is negligible.

9702/12/M/J/15/Q10

What is the acceleration before and after 5 seconds?

	before 5 seconds	after 5 seconds
<b>A</b>	constant	constant
<b>B</b>	constant	zero
<b>C</b>	increasing	constant
<b>D</b>	increasing	zero

- 125 Trolley X, moving along a horizontal frictionless track, collides with a stationary trolley Y. The two trolleys become attached and move off together. 9702/12/M/J/15/Q11

Which statement about this interaction is correct?

- A** Some of the kinetic energy of trolley X is changed to momentum in the collision.  
**B** Some of the momentum of trolley X is changed to kinetic energy in the collision.  
**C** Trolley X loses some of its momentum as heat in the collision.  
**D** Trolley X shares its momentum with trolley Y but some of its kinetic energy is lost.
- 126 What is a reasonable estimate of the average gravitational force acting on a fully grown woman standing on the Earth? 9702/11/M/J/15/Q10

- A** 60 N                      **B** 250 N                      **C** 350 N                      **D** 650 N

- 127 A molecule of mass  $m$  travelling at speed  $v$  hits a wall in a direction perpendicular to the wall. The collision is elastic. 9702/11/M/J/15/Q11

What are the changes in the momentum and in the kinetic energy of the molecule caused by the collision?

	change in momentum	change in kinetic energy
<b>A</b>	0	0
<b>B</b>	0	$mv^2$
<b>C</b>	$2mv$	0
<b>D</b>	$mv^2$	0

- 128 What is the **definition** of the force on a body? 9702/11/M/J/15/Q14

- A** the mass of the body multiplied by its acceleration  
**B** the power input to the body divided by its velocity  
**C** the rate of change of momentum of the body  
**D** the work done on the body divided by its displacement



1 Which of the following correctly defines the terms *stress*, *strain* and *Young modulus*?

9702/1/M/J/02/Q22

	stress	strain	Young modulus
<b>A</b>	(force) x (area)	(extension) x (original length)	(stress) / (strain)
<b>B</b>	(force) x (area)	(extension) / (original length)	(stress) x (strain)
<b>C</b>	(force) / (area)	(extension) / (original length)	(stress) / (strain)
<b>D</b>	(force) / (area)	(extension) x (original length)	(stress) x (strain)

2 A wire is stretched by 8 mm when a load of 60 N is applied. 9702/1/M/J/02/Q23

What will be the extension of a wire of the same material having four times the cross-sectional area and twice the original length, when the same load is applied?

- A** 2 mm      **B** 4 mm      **C** 8 mm      **D** 16 mm

3 The tension in a spring of natural length  $l_0$  is first increased from zero to  $T_1$ , causing the length to increase to  $l_1$ . The tension is then reduced to  $T_2$ , causing the length to decrease to  $l_2$  (as shown).

9702/1/M/J/02/Q24

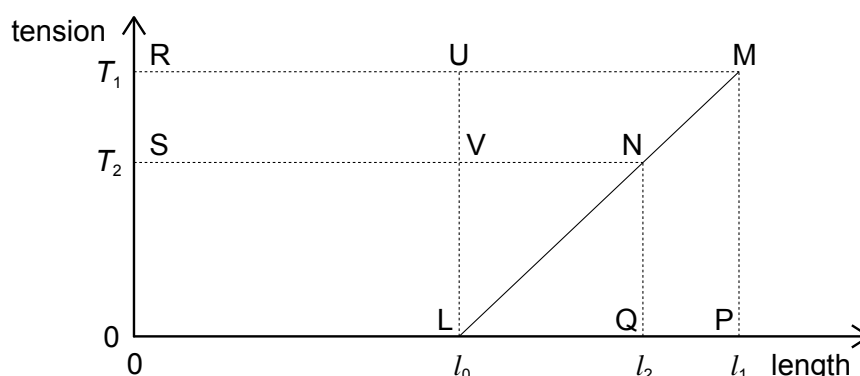

Which area of the graph represents the work done by the spring during this reduction in length?

- A** MLP      **B** MNQP      **C** MNSR      **D** MPLU

4 Two springs P and Q both obey Hooke's law. They have spring constants  $2k$  and  $k$  respectively.

The springs are stretched, separately, by a force that is gradually increased from zero up to a certain maximum value, the same for each spring. The work done in stretching spring P is  $W_P$ , and the work done in stretching spring Q is  $W_Q$ .

9702/1/O/N/02/Q24

How is  $W_P$  related to  $W_Q$ ?

- A**  $W_P = \frac{1}{4}W_Q$       **B**  $W_P = \frac{1}{2}W_Q$       **C**  $W_P = 2W_Q$       **D**  $W_P = 4W_Q$

- 5 The variation of the extension  $x$  of a spring with applied force  $F$  is shown. 9702/1/O/N/02/Q23

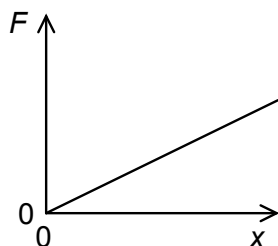

Which shaded area represents the work done when the extension is increased from  $x_1$  to  $x_2$ ?

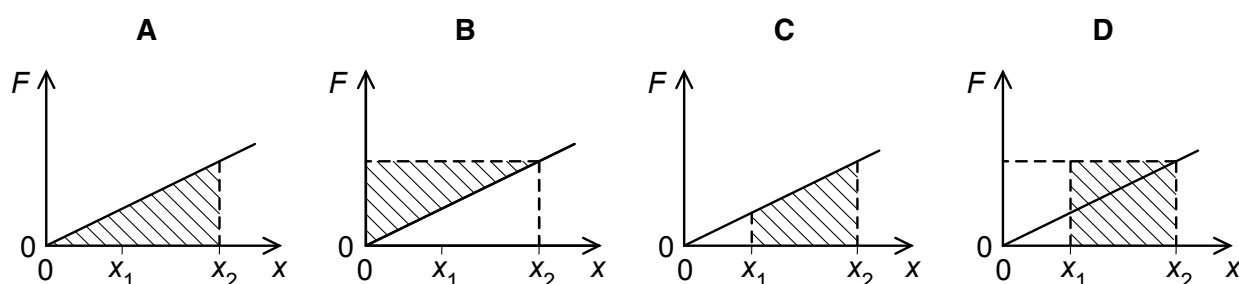

- 6 A suspended copper wire is gradually loaded until it is stretched just beyond the elastic limit, and it is then gradually unloaded. 9702/01/M/J/03/Q19

Which graph (with arrows indicating the sequence) best illustrates the variation of the tensile stress with longitudinal strain?

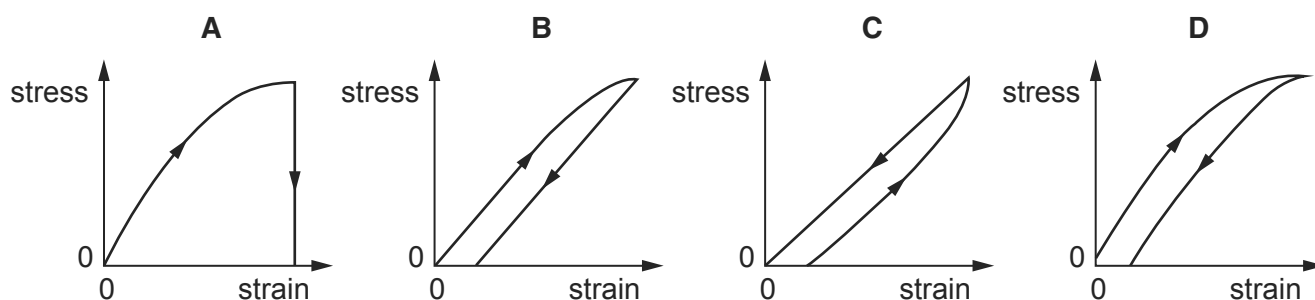

- 7 What is the ultimate tensile stress of a material? 9702/01/M/J/03/Q21

- A the stress at which the material becomes ductile
- B the stress at which the material breaks
- C the stress at which the material deforms plastically
- D the stress at which the material reaches its elastic limit

- 8 A beam, the weight of which may be neglected, is supported by three identical springs. When a weight  $W$  is hung from the middle of the beam, the extension of each spring is  $x$ .

9702/01/M/J/03/Q22

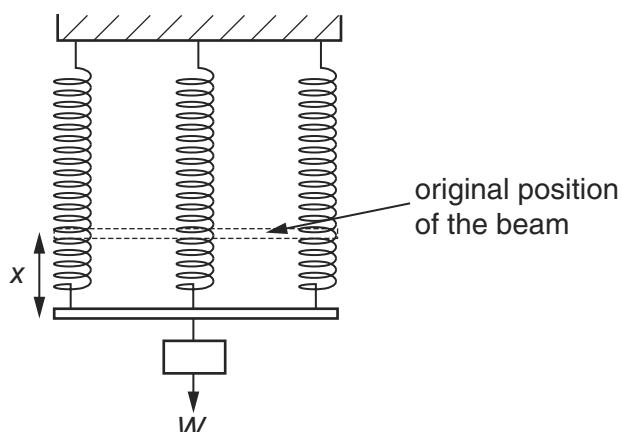

The middle spring and the weight are removed.

What is the extension when a weight of  $2W$  is hung from the middle of the beam?

- A  $\frac{3x}{2}$       B  $\frac{4x}{3}$       C  $2x$       D  $3x$

- 9 What is the Young modulus of a metal? 9702/01/O/N/03/Q21

- A extension / force  
 B force / extension  
 C strain / stress  
 D stress / strain

- 10 The graph shows how the extension of a spring varies with the force used to stretch it. 9702/01/O/N/03/Q22

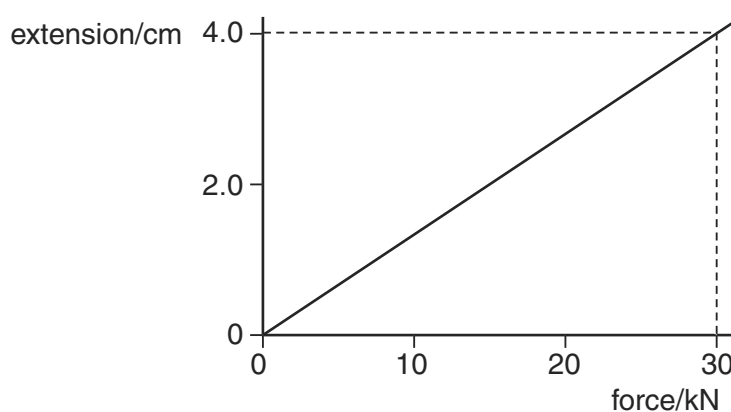

What is the strain energy stored in the spring when the extension is 4.0 cm?

- A 60 J      B 120 J      C 600 J      D 1200 J

- 11 The graph shown was plotted in an experiment on a metal wire. 9702/01/M/J/04/Q22

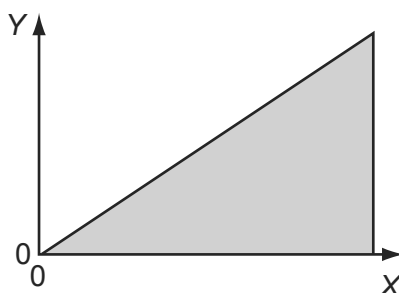

The shaded area represents the total strain energy stored in stretching the wire.

How should the axes be labelled?

	Y	X
<b>A</b>	force	extension
<b>B</b>	mass	extension
<b>C</b>	strain	energy
<b>D</b>	stress	strain

- 12 Nylon breaks when the stress within it reaches  $1 \times 10^9$  Pa. 9702/01/M/J/04/Q23

Which range includes the heaviest load that could be lifted by a nylon thread of diameter 1 mm?

- A** 2 N to 20 N  
**B** 20 N to 200 N  
**C** 200 N to 2000 N  
**D** 2000 N to 20 000 N
- 13 The table shows a load applied to four wires and the cross-sectional area of each. 9702/01/O/N/04/Q22

Which of the wires is subjected to the greatest stress?

	load / N	cross-sectional area / mm <sup>2</sup>
<b>A</b>	1500	0.25
<b>B</b>	2000	1.0
<b>C</b>	3000	0.56
<b>D</b>	5000	2.3

- 14 The force  $F$  required to extend a sample of rubber by a distance  $x$  is found to vary as shown.

9702/01/O/N/04/Q23

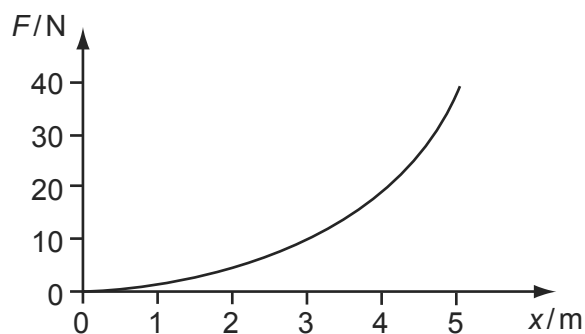

The energy stored in the rubber for an extension of 5 m is

- A** less than 100 J.  
**B** 100 J.  
**C** between 100 J and 200 J.  
**D** more than 200 J.
- 15 A number of similar springs, each having the same spring constant, are joined in three arrangements X, Y and Z. The same load is applied to each. 9702/01/M/J/05/Q20

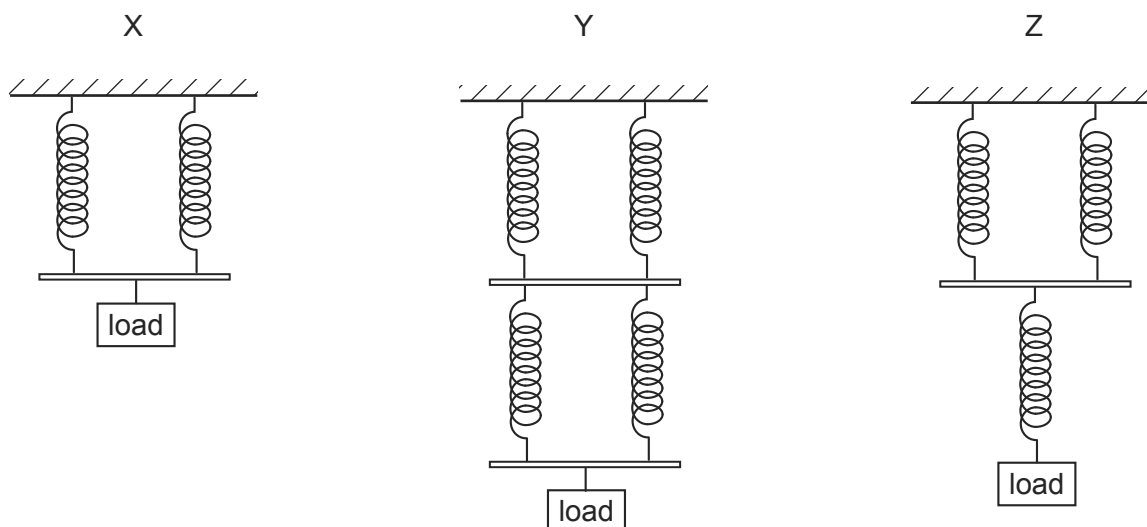

What is the order of increasing extension for these arrangements?

	smallest	→	largest
<b>A</b>	X	Y	Z
<b>B</b>	Z	X	Y
<b>C</b>	Z	Y	X
<b>D</b>	Y	X	Z

- 16 Cylindrical samples of steel, glass and rubber are each subjected to a gradually increasing tensile force  $F$ . The extensions  $e$  are measured and graphs are plotted as shown below. 9702/01/M/J/05/Q21

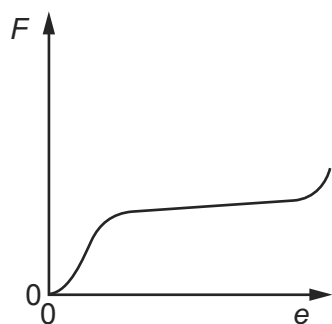

graph X

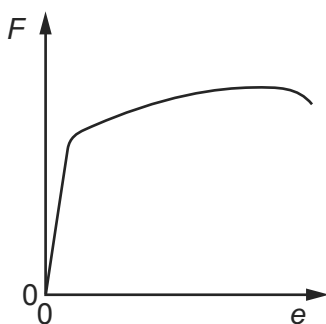

graph Y

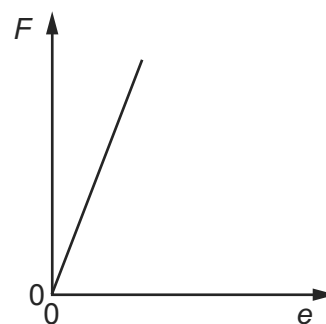

graph Z

Which row correctly relates the graphs to the materials?

	steel	glass	rubber
<b>A</b>	X	Y	Z
<b>B</b>	X	Z	Y
<b>C</b>	Y	X	Z
<b>D</b>	Y	Z	X

- 17 Two steel wires P and Q have lengths  $l$  and  $2l$  respectively, and cross-sectional areas  $A$  and  $\frac{A}{2}$  respectively. Both wires obey Hooke's law. 9702/01/M/J/05/Q22

What is the ratio  $\frac{\text{tension in P}}{\text{tension in Q}}$  when both wires are stretched to the same extension?

- A**  $\frac{1}{4}$       **B**  $\frac{1}{2}$       **C**  $\frac{2}{1}$       **D**  $\frac{4}{1}$

- 18 In describing the behaviour of a spring, the spring constant is used. 9702/01/M/J/06/Q21

Different loads are used to extend the spring by different amounts.

To find the spring constant, which quantities are required?

- A** the elastic limit and the loads  
**B** the elastic limit, extensions and the length of the spring  
**C** the loads and the extensions of the spring  
**D** the loads and the length of the spring

- 19 What is the unit of the Young modulus? 9702/01/O/N/06/Q23

- A**  $\text{Nm}^{-1}$       **B**  $\text{Nm}$       **C**  $\text{Nm}^{-2}$       **D**  $\text{Nm}^2$

- 20 A wire stretches 8 mm under a load of 60 N. 9702/01/O/N/05/Q21

A second wire of the same material, with half the diameter and a quarter of the original length of the first wire, is stretched by the same load.

Assuming that Hooke's law is obeyed, what is the extension of this wire?

- A** 1 mm      **B** 4 mm      **C** 8 mm      **D** 16 mm
- 21 A ductile material is stretched by a tensile force to a point beyond its elastic limit. The tensile force is then reduced to zero. The graph of force against extension is shown below. 9702/01/O/N/05/Q20

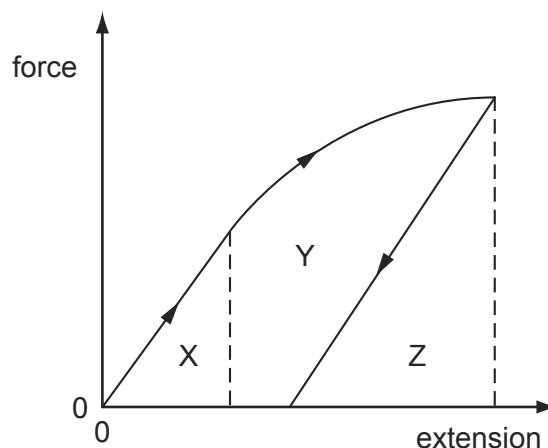

Which area represents the net work done on the sample?

- A** X      **B** X + Y      **C** Y + Z      **D** Z
- 22 The graph shows the behaviour of a sample of a metal when it is stretched until it starts to undergo plastic deformation. 9702/01/M/J/06/Q22

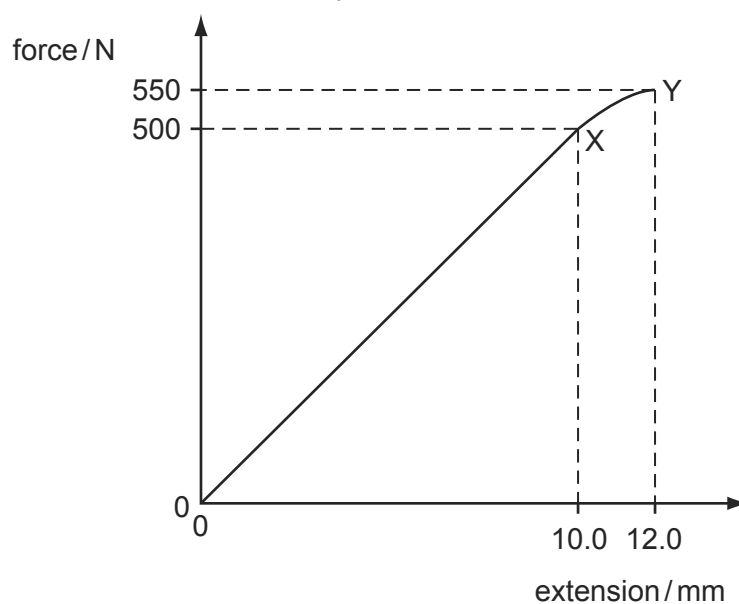

What is the total work done in stretching the sample from zero extension to 12.0 mm? Simplify the calculation by treating the region XY as a straight line.

- A** 3.30 J      **B** 3.55 J      **C** 3.60 J      **D** 6.60 J

23 What is represented by the gradient of a graph of force (vertical axis) against extension (horizontal axis)? 9702/01/O/N/06/Q22

- A elastic limit
- B spring constant
- C stress
- D the Young modulus

24 A piece of copper is drawn into a continuous wire. 9702/01/M/J/07/Q17

What behaviour is the copper exhibiting?

- A brittle only
- B elastic only
- C plastic only
- D both brittle and elastic

25 The force-extension graph of a particular sample of rubber as a load is applied and then removed is shown. 9702/01/M/J/07/Q18

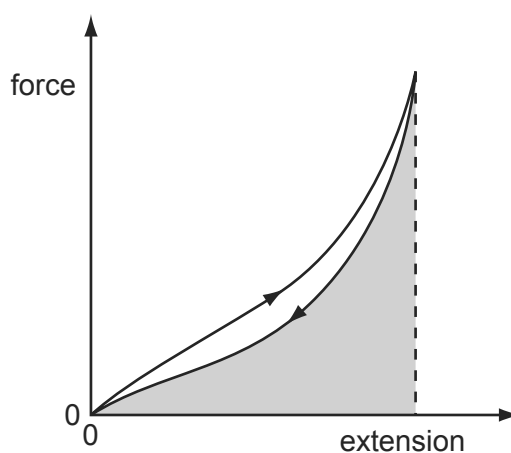

What does the shaded area represent?

- A the energy transformed into heat during the complete cycle
- B the recoverable elastic potential energy stored at maximum extension
- C the work done on the sample while loading
- D the work done on the sample while unloading



- 26 A spring of unextended length 0.50 m is stretched by a force of 2.0 N to a new length of 0.90 m. The variation of its length with tension is as shown. 9702/01/M/J/07/Q19

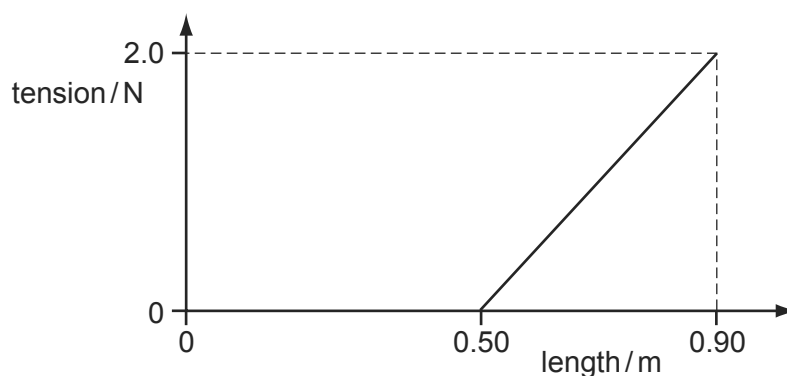

How much strain energy is stored in the spring?

- A** 0.40 J      **B** 0.80 J      **C** 0.90 J      **D** 1.8 J
- 27 A simple crane consists of a rigid vertical pillar supporting a horizontal beam. 9702/01/M/J/07/Q20

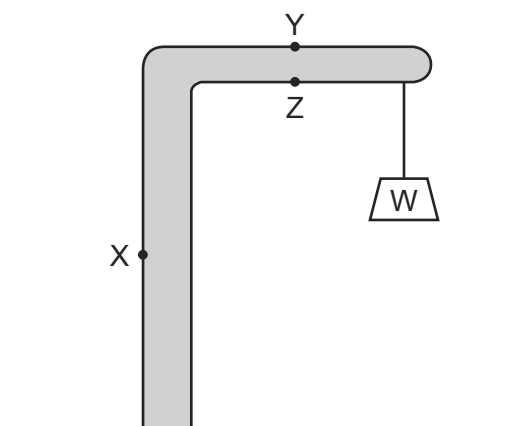

A weight  $W$  is lifted by a rope at the end of the beam.

What are the forces at points  $X$ ,  $Y$  and  $Z$  due to the weight  $W$ ?

	force at $X$	force at $Y$	force at $Z$
<b>A</b>	tension	compression	tension
<b>B</b>	tension	tension	compression
<b>C</b>	compression	tension	compression
<b>D</b>	compression	compression	compression

28 What is plastic deformation? 9702/01/O/N/07/Q19

- A** Plastic deformation occurs when strain is not proportional to stress but when the load is removed the material returns to its original length.
- B** Plastic deformation occurs if, when the load is removed, the material contracts but a permanent stretching has occurred.
- C** Plastic deformation occurs until the extension is no longer proportional to the load.
- D** Plastic deformation occurs when the material extends so that strain is directly proportional to stress.

29 The graph shows how the length of a particular rubber cord varies as force is applied. 9702/01/O/N/07/Q20

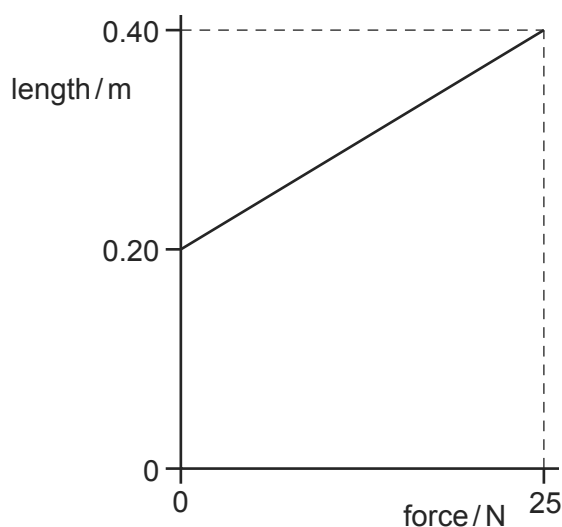

What is the maximum strain energy in this deformed rubber cord?

- A** 2.5 J
- B** 5.0 J
- C** 7.5 J
- D** 10 J

30 The Young modulus of steel is determined using a length of steel wire and is found to have the value  $E$ .

Another experiment is carried out using a wire of the same steel, but of twice the length and half the diameter.

What value is obtained for the Young modulus in the second experiment? 9702/01/M/J/08/Q24

- A**  $\frac{1}{4}E$
- B**  $\frac{1}{2}E$
- C**  $E$
- D**  $2E$

31 Which properties best describe modelling clay? 9702/01/O/N/08/Q19

- A** brittle and ductile
- B** ductile and elastic
- C** elastic and plastic
- D** plastic and ductile

- 32 A sample of metal is subjected to a force which increases to a maximum value and then decreases back to zero. A force-extension graph for the sample is shown. 9702/01/M/J/08/Q22

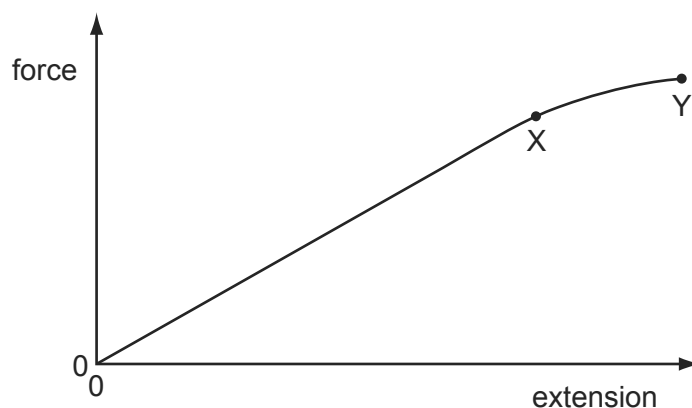

When the sample contracts it follows the same force-extension curve as when it was being stretched.

What is the behaviour of the metal between X and Y?

- A both elastic and plastic
  - B elastic but not plastic
  - C plastic but not elastic
  - D not elastic and not plastic
- 33 A spring of original length 100 mm is compressed by a force. The graph shows the variation of the length  $L$  of the spring with the compressing force  $F$ . 9702/01/M/J/08/Q23

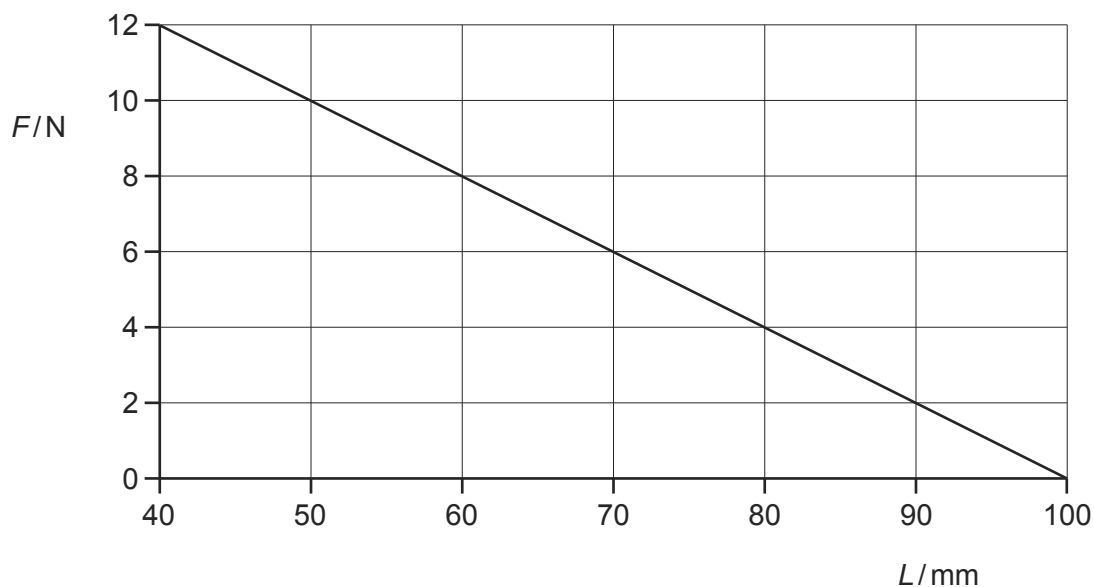

What is the energy stored in the spring when the length is 70 mm?

- A 0.090 J
- B 0.21 J
- C 0.27 J
- D 0.63 J

- 34 Why does the pressure of a gas increase when the gas is compressed at constant temperature?
- A** The gas molecules collide more often with each other.  
**B** The gas molecules expand under pressure.  
**C** The gas molecules hit the walls of the container more frequently.  
**D** The gas molecules travel faster.

- 35 Four materials are formed into rods of the same dimensions. 9702/01/M/J/09/Q19

At room temperature, which can sustain the largest plastic deformation?

- A** the ductile material aluminium  
**B** the brittle material carbon  
**C** the brittle material glass  
**D** the ductile material steel
- 36 Two steel wires P and Q have lengths  $l$  and  $2l$  respectively, and cross-sectional areas  $A$  and  $\frac{A}{2}$  respectively. Both wires obey Hooke's law. 9702/01/M/J/09/Q20

What is the ratio  $\frac{\text{tension in P}}{\text{tension in Q}}$  when both wires are stretched to the same extension?

- A**  $\frac{1}{4}$       **B**  $\frac{1}{2}$       **C**  $\frac{2}{1}$       **D**  $\frac{4}{1}$

- 37 A rubber band is stretched by hanging weights on it and the force-extension graph is plotted from the results. 9702/01/M/J/09/Q21

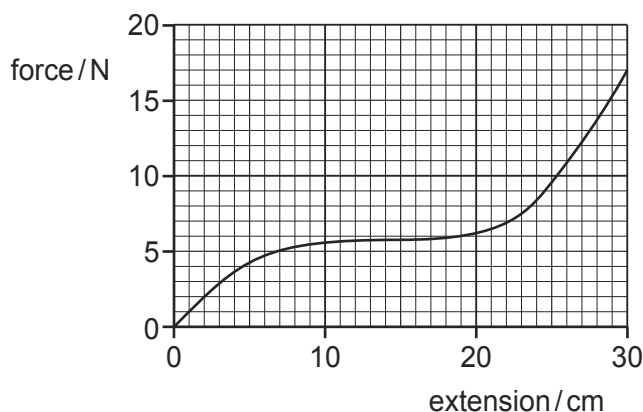

What is the best estimate of the strain energy stored in the rubber band when it is extended 30 cm?

- A** 2.0 J      **B** 2.6 J      **C** 5.1 J      **D** 200 J

- 38 A number of similar springs, each having the same spring constant, are joined in four arrangements. The same load is applied to each.

Which arrangement gives the greatest extension?

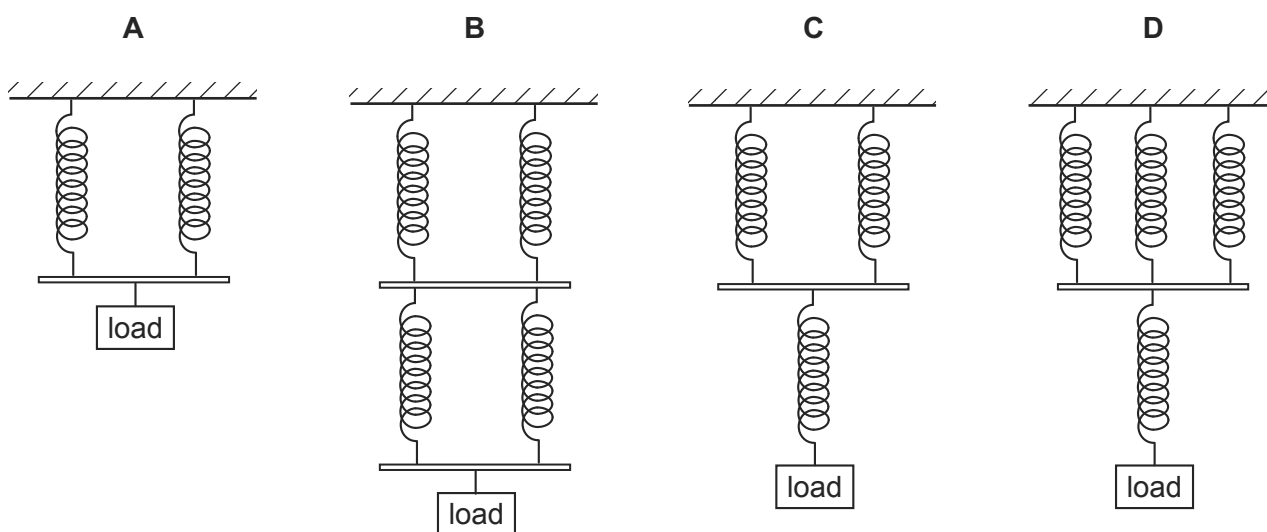

- 39 The graphs show how force varies with extension and stress varies with strain for the loading of a metal wire. 9702/01/O/N/08/Q22

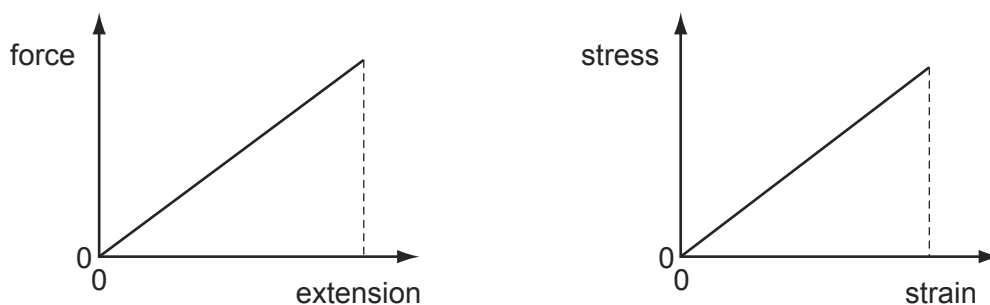

The Young modulus for this wire is equal to

- A** the gradient of the force-extension graph.  
**B** the area between the force-extension graph and the extension axis.  
**C** the gradient of the stress-strain graph.  
**D** the area between the stress-strain graph and the strain axis.
- 40 For a wire, Hooke's law is obeyed for a tension  $F$  and extension  $x$ . The Young modulus for the material of the wire is  $E$ .

Which expression represents the elastic strain energy stored in the wire?

- A**  $\frac{1}{2} Ex$       **B**  $Ex$       **C**  $\frac{1}{2} Fx$       **D**  $Fx$

- 41 Which row best defines elastic and plastic behaviour of a material? 9702/11/O/N/09/Q20

	elastic behaviour of a material	plastic behaviour of a material
<b>A</b>	extends only within the limit of proportionality	extends beyond the limit of proportionality
<b>B</b>	has a linear force-extension curve	has a horizontal force-extension curve
<b>C</b>	obeys Hooke's Law	extends continuously under a steady load
<b>D</b>	returns to its original shape and size	suffers permanent deformation

- 42 The graph shows the non-linear force-extension curve for a wire made from a new composite material. 9702/11/O/N/09/Q21

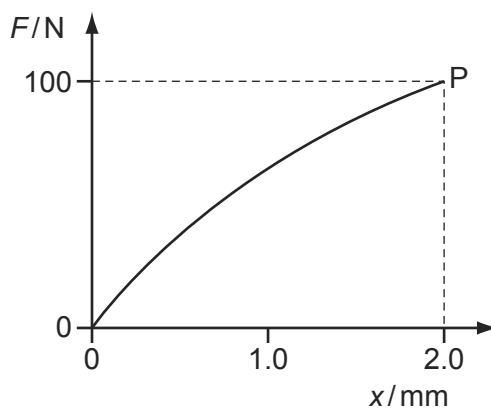

What could be the value of the strain energy stored in the wire when it is stretched to point P?

- A** 0.09 J      **B** 0.10 J      **C** 0.11 J      **D** 0.20 J
- 43 A steel string on an electric guitar has the following properties. 9702/11/O/N/09/Q22

$$\text{diameter} = 5.0 \times 10^{-4} \text{ m}$$

$$\text{Young modulus} = 2.0 \times 10^{11} \text{ Pa}$$

$$\text{tension} = 20 \text{ N}$$

The string snaps, and contracts elastically.

By what percentage does a length  $l$  of a piece of the string contract?

- A**  $5.1 \times 10^{-4} \%$     **B**  $5.1 \times 10^{-2} \%$     **C**  $1.3 \times 10^{-4} \%$     **D**  $1.3 \times 10^{-2} \%$
- 44 Which row best defines elastic and plastic behaviour of a material? 9702/12/O/N/09/Q19

	elastic behaviour of a material	plastic behaviour of a material
<b>A</b>	extends only within the limit of proportionality	extends beyond the limit of proportionality
<b>B</b>	has a linear force-extension curve	has a horizontal force-extension curve
<b>C</b>	obeys Hooke's Law	extends continuously under a steady load
<b>D</b>	returns to its original shape and size	suffers permanent deformation

- 45 The graph shows the non-linear force-extension curve for a wire made from a new composite material. 9702/12/O/N/09/Q20

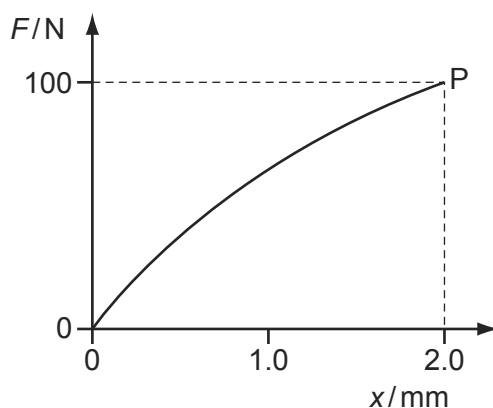

What could be the value of the strain energy stored in the wire when it is stretched to point P?

- A** 0.09J      **B** 0.10J      **C** 0.11J      **D** 0.20J
- 46 A steel string on an electric guitar has the following properties. 9702/12/O/N/09/Q21

$$\text{diameter} = 5.0 \times 10^{-4} \text{ m}$$

$$\text{Young modulus} = 2.0 \times 10^{11} \text{ Pa}$$

$$\text{tension} = 20 \text{ N}$$

The string snaps, and contracts elastically.

By what percentage does a length  $l$  of a piece of the string contract?

- A**  $5.1 \times 10^{-4}\%$     **B**  $5.1 \times 10^{-2}\%$     **C**  $1.3 \times 10^{-4}\%$     **D**  $1.3 \times 10^{-2}\%$
- 47 In stress-strain experiments on metal wires, the stress axis is often marked in units of  $10^8$  Pa and the strain axis is marked as a percentage. This is shown for a particular wire in the diagram. 9702/11/M/J/10/Q19

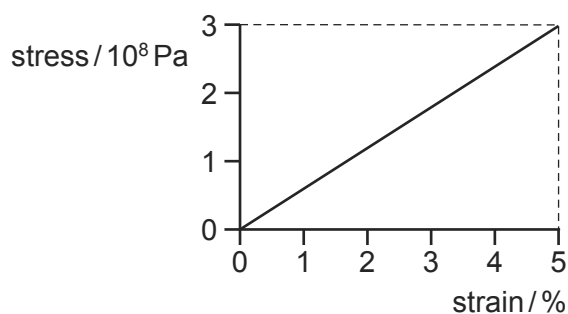

What is the value of the Young modulus for the material of the wire?

- A**  $6.0 \times 10^7$  Pa    **B**  $7.5 \times 10^8$  Pa    **C**  $1.5 \times 10^9$  Pa    **D**  $6.0 \times 10^9$  Pa

- 48 A spring is compressed by a force. The graph shows the compressing force  $F$  plotted against the length  $L$  of the spring. 9702/11/M/J/10/Q20

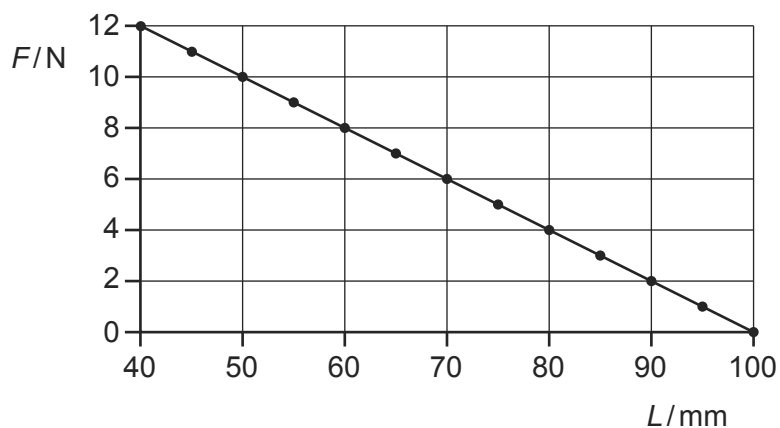

What is the spring constant of this spring?

- A**  $0.2 \text{ Nm}^{-1}$       **B**  $5 \text{ Nm}^{-1}$       **C**  $100 \text{ Nm}^{-1}$       **D**  $200 \text{ Nm}^{-1}$
- 49 Which graph represents the force-extension relationship of a rubber band that is stretched almost to its breaking point? 9702/11/M/J/10/Q21

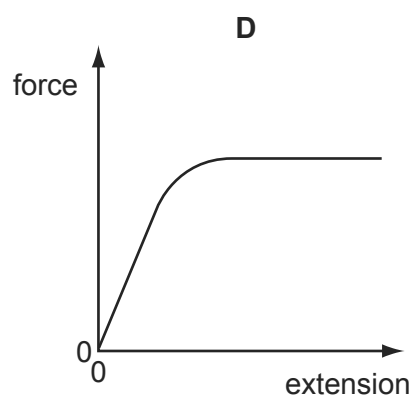
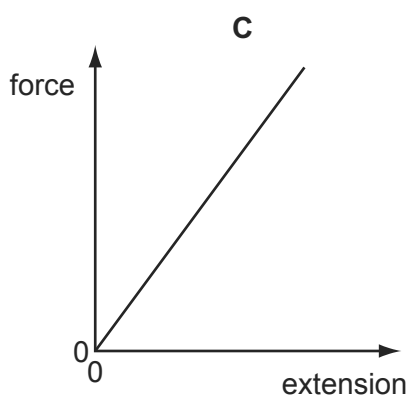
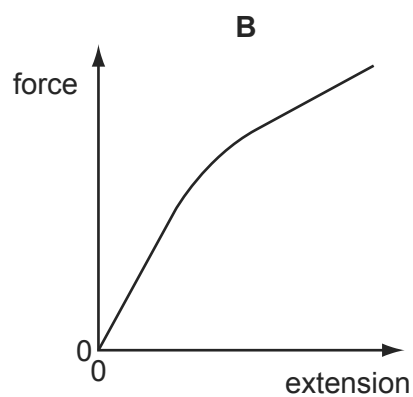
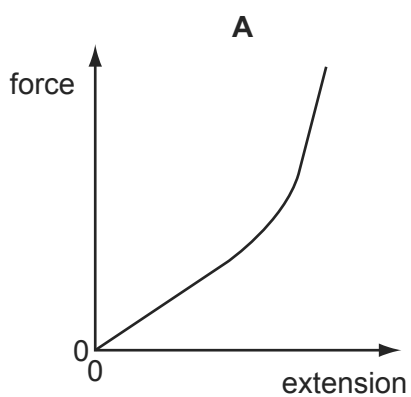



- 50 A spring is compressed by a force. The graph shows the compressing force  $F$  plotted against the length  $L$  of the spring. 9702/12/M/J/10/Q19

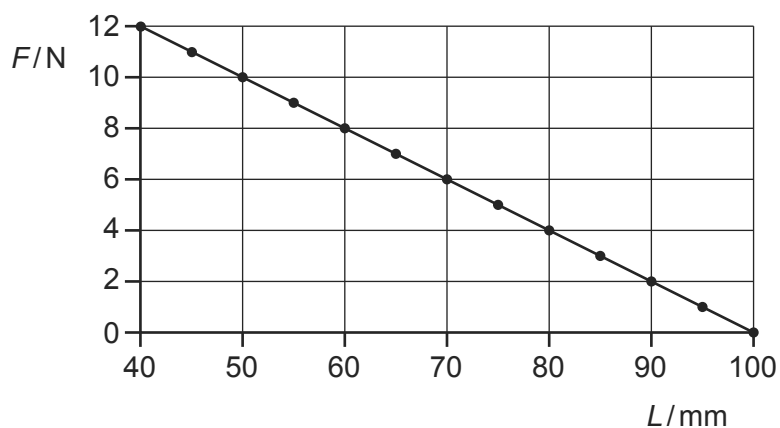

What is the spring constant of this spring?

- A  $0.2 \text{ Nm}^{-1}$       B  $5 \text{ Nm}^{-1}$       C  $100 \text{ Nm}^{-1}$       D  $200 \text{ Nm}^{-1}$
- 51 Which graph represents the force-extension relationship of a rubber band that is stretched almost to its breaking point? 9702/12/M/J/10/Q20

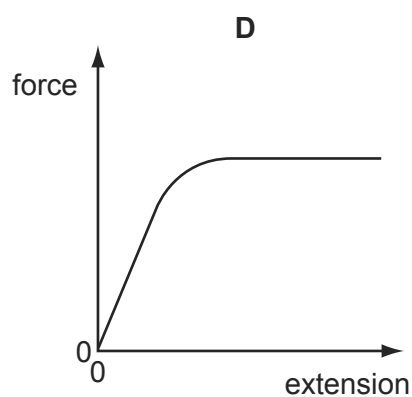
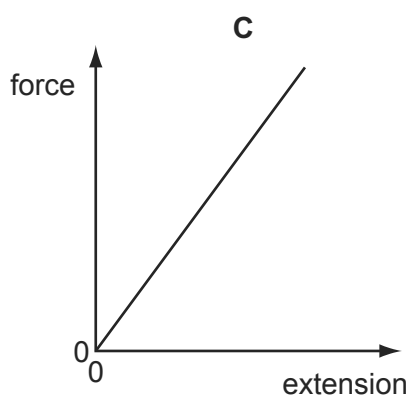
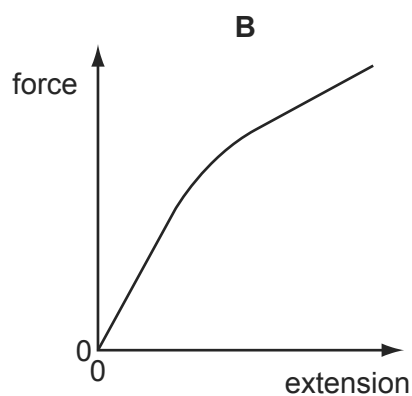
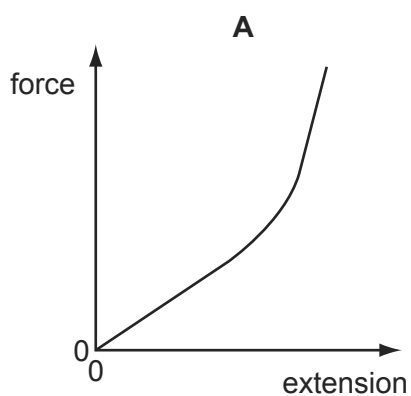

- 52 In stress-strain experiments on metal wires, the stress axis is often marked in units of  $10^8$  Pa and the strain axis is marked as a percentage. This is shown for a particular wire in the diagram.

9702/12/M/J/10/Q21

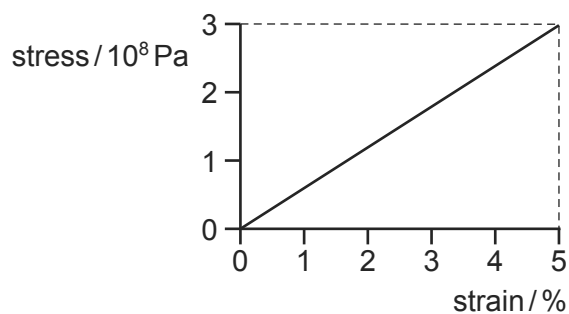

What is the value of the Young modulus for the material of the wire?

- A**  $6.0 \times 10^7$  Pa    **B**  $7.5 \times 10^8$  Pa    **C**  $1.5 \times 10^9$  Pa    **D**  $6.0 \times 10^9$  Pa
- 53 Which graph represents the force-extension relationship of a rubber band that is stretched almost to its breaking point? 9702/13/M/J/10/Q19

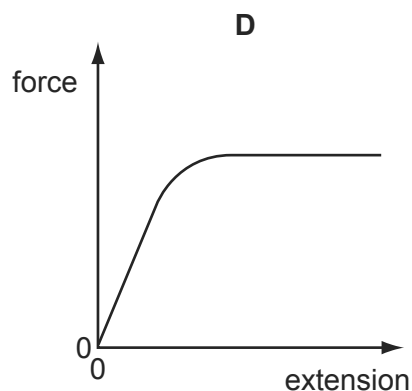
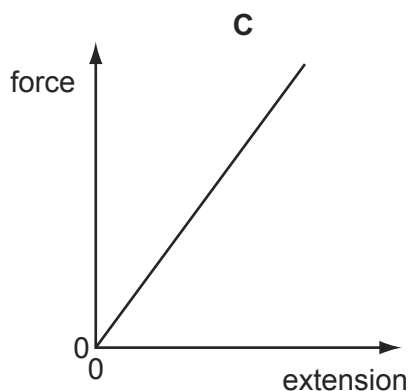
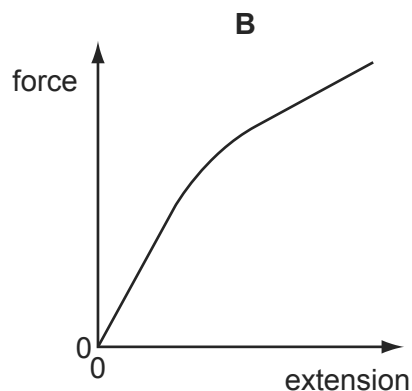
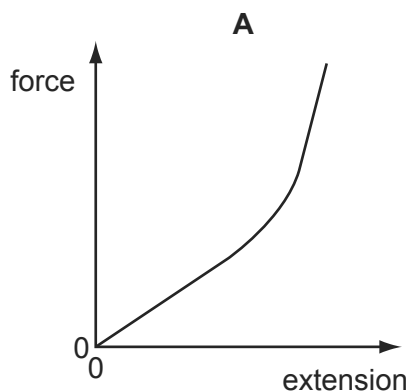

- 54 In which order of magnitude are the frequencies of electromagnetic waves in the visible spectrum? 9702/12/M/J/11/Q25
- A**  $10^{12}$  Hz    **B**  $10^{13}$  Hz    **C**  $10^{14}$  Hz    **D**  $10^{15}$  Hz

- 55 In stress-strain experiments on metal wires, the stress axis is often marked in units of  $10^8$  Pa and the strain axis is marked as a percentage. This is shown for a particular wire in the diagram.

9702/13/M/J/10/Q20

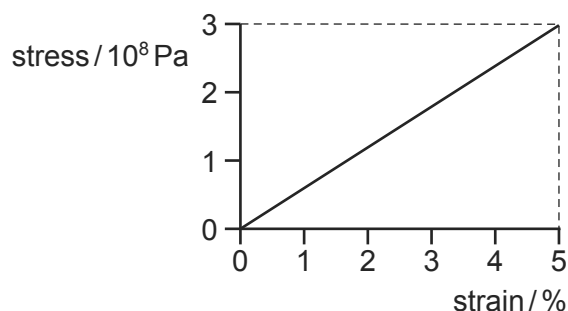

What is the value of the Young modulus for the material of the wire?

- A**  $6.0 \times 10^7$  Pa    **B**  $7.5 \times 10^8$  Pa    **C**  $1.5 \times 10^9$  Pa    **D**  $6.0 \times 10^9$  Pa
- 56 A spring is compressed by a force. The graph shows the compressing force  $F$  plotted against the length  $L$  of the spring. 9702/13/M/J/10/Q21

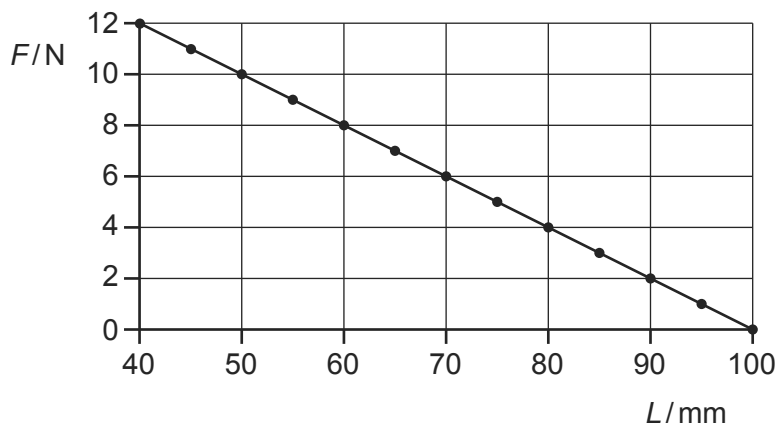

What is the spring constant of this spring?

- A**  $0.2 \text{ N m}^{-1}$     **B**  $5 \text{ N m}^{-1}$     **C**  $100 \text{ N m}^{-1}$     **D**  $200 \text{ N m}^{-1}$
- 57 Using monochromatic light, interference fringes are produced on a screen placed a distance  $D$  from a pair of slits of separation  $a$ . The separation of the fringes is  $x$ . 9702/13/M/J/10/Q22

Both  $a$  and  $D$  are now doubled.

What is the new fringe separation?

- A**  $\frac{x}{2}$     **B**  $x$     **C**  $2x$     **D**  $4x$
- 58 The pressure at sea level is approximately  $100\,000$  Pa. The density of sea water is  $1030 \text{ kg m}^{-3}$ .

What is the approximate pressure 80 m below the surface of the sea? 9702/12/O/N/10/Q20

- A**  $100\,000$  Pa    **B**  $180\,000$  Pa    **C**  $800\,000$  Pa    **D**  $900\,000$  Pa

- 59 The graph shows how force depends on extension for a certain spring. 9702/11/O/N/10/Q21

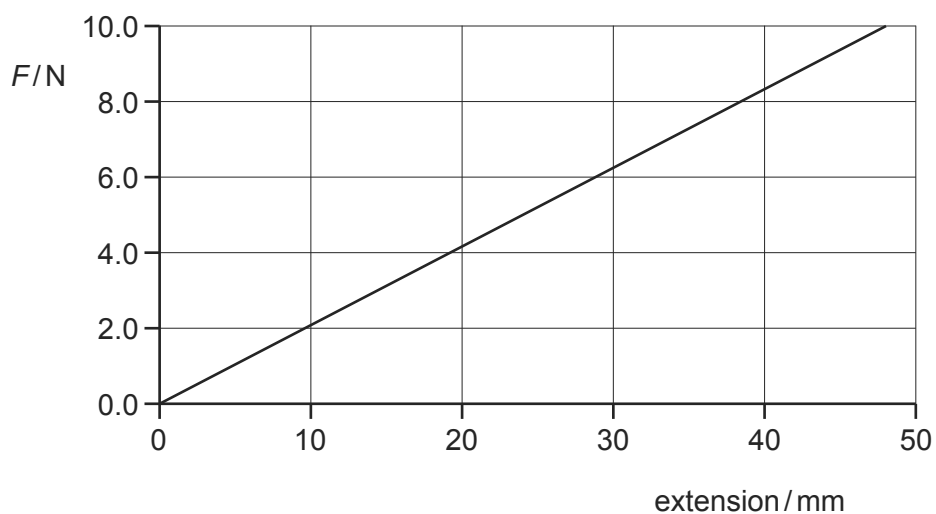

What is the energy stored in the spring when the extension is 30 mm?

- A** 0.095 J      **B** 0.19 J      **C** 0.25 J      **D** 0.95 J
- 60 A wire consists of a 3.0 m length of metal X joined to a 1.0 m length of metal Y. 9702/11/O/N/10/Q22

The cross-sectional area of the wire is uniform.

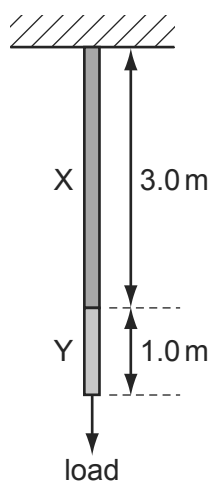

A load hung from the wire causes metal X to stretch by 1.5 mm and metal Y to stretch by 1.0 mm.

The same load is then hung from a second wire of the same cross-section, consisting of 1.0 m of metal X and 3.0 m of metal Y.

What is the total extension of this second wire?

- A** 2.5 mm      **B** 3.5 mm      **C** 4.8 mm      **D** 5.0 mm

- 61 Two wires P and Q are made from the same material. 9702/12/O/N/10/Q21

Wire P is initially twice the diameter and twice the length of wire Q. The same force, applied to each wire, causes the wires to extend elastically.

What is the ratio of the extension in P to that in Q?

- A**  $\frac{1}{2}$                       **B** 1                      **C** 2                      **D** 4

- 62 To determine the mass of food in a pan, a scale is used that has high sensitivity for small masses but low sensitivity for large masses. 9702/12/O/N/10/Q22

To do this, two springs are used, each with a different spring constant  $k$ . One of the springs has a low spring constant and the other has a high spring constant.

Which arrangement of springs would be suitable?

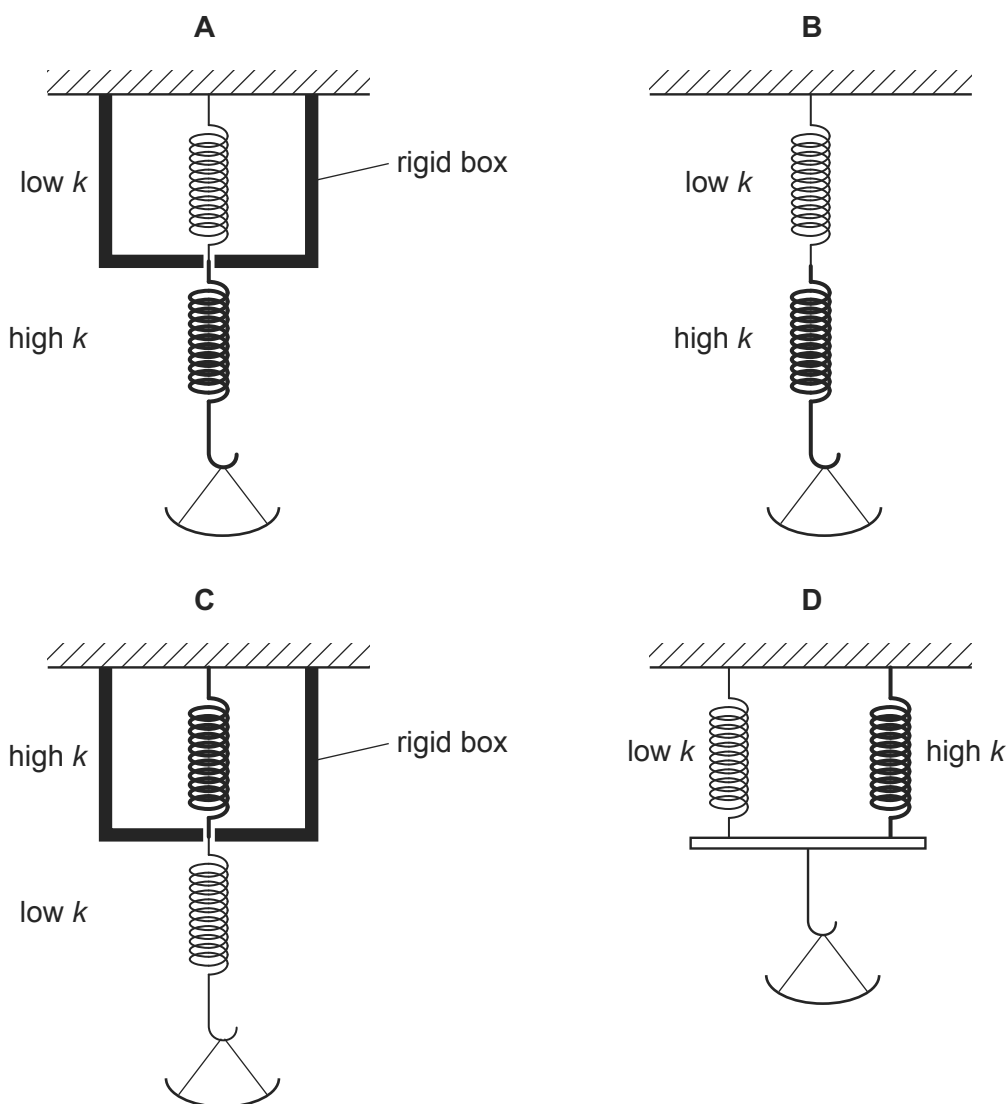

- 63 The graph shows how force depends on extension for a certain spring. 9702/13/O/N/10/Q19

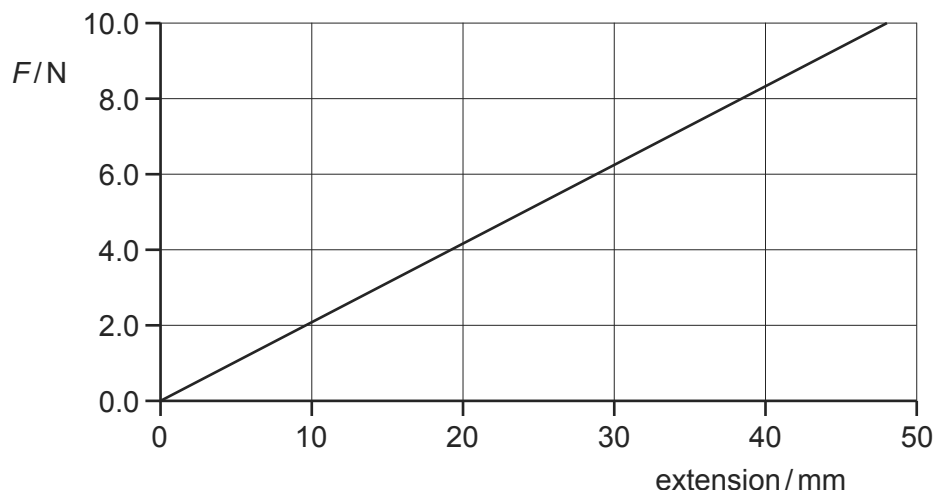

What is the energy stored in the spring when the extension is 30 mm?

- A** 0.095 J      **B** 0.19 J      **C** 0.25 J      **D** 0.95 J
- 64 The Mariana Trench in the Pacific Ocean has a depth of about 10 km. 9702/13/O/N/10/Q20
- Assuming that sea water is incompressible and has a density of about  $1020 \text{ kg m}^{-3}$ , what would be the approximate pressure at that depth?
- A**  $10^5 \text{ Pa}$       **B**  $10^6 \text{ Pa}$       **C**  $10^7 \text{ Pa}$       **D**  $10^8 \text{ Pa}$
- 65 A wire consists of a 3.0 m length of metal X joined to a 1.0 m length of metal Y. 9702/13/O/N/10/Q21
- The cross-sectional area of the wire is uniform.

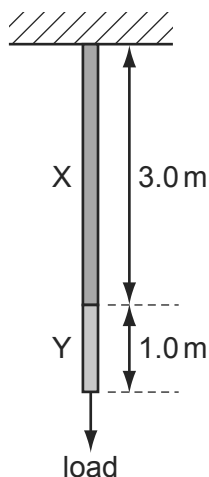

A load hung from the wire causes metal X to stretch by 1.5 mm and metal Y to stretch by 1.0 mm.

The same load is then hung from a second wire of the same cross-section, consisting of 1.0 m of metal X and 3.0 m of metal Y.

What is the total extension of this second wire?

- A** 2.5 mm      **B** 3.5 mm      **C** 4.8 mm      **D** 5.0 mm

- 66 A long, thin metal wire is suspended from a fixed support and hangs vertically. Masses are suspended from its lower end. 9702/11/M/J/11/Q20

The load on the lower end is increased from zero and then decreased again back to zero.

The diagram shows the force-extension graph produced.

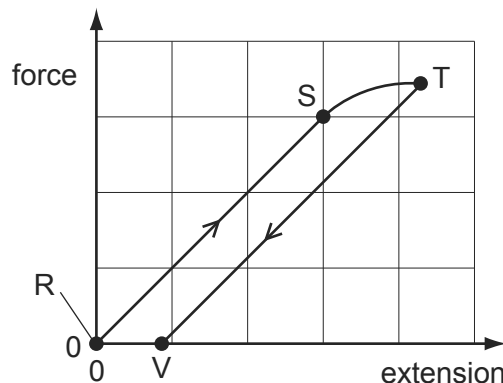

Where on the graph would the elastic limit be found?

- A** anywhere between point R and point S  
**B** beyond point S but before point T  
**C** exactly at point S  
**D** exactly at point T
- 67 The Young modulus  $E$  can be determined from measurements made when a wire is stretched.

Which quantities would be measured in order to determine  $E$ ? 9702/11/M/J/11/Q21

<b>A</b>	mass of stretching load	original length of wire	diameter of wire	extension of wire
<b>B</b>	mass of stretching load	new length of wire	cross-sectional area of wire	diameter of wire
<b>C</b>	mass of wire	original length of wire	cross-sectional area of wire	new length of wire
<b>D</b>	mass of wire	new length of wire	diameter of wire	extension of wire

- 68 The behaviour of a wire under tensile stress may be described in terms of the Young modulus  $E$  of the material of the wire and of the force per unit extension  $k$  of the wire. 9702/12/M/J/11/Q23

For a wire of length  $L$  and cross-sectional area  $A$ , what is the relation between  $E$  and  $k$ ?

- A**  $E = \frac{A}{kL}$       **B**  $E = \frac{kA}{L}$       **C**  $E = \frac{kL}{A}$       **D**  $E = \frac{L}{kA}$

- 69 The diagram shows the structure of part of a mattress. 9702/12/M/J/11/Q24

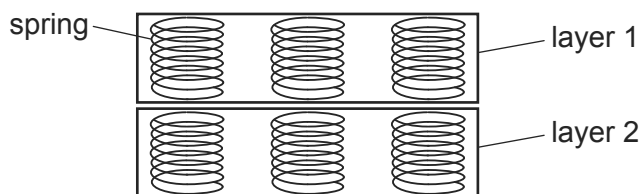

The manufacturer wants to design a softer mattress (one which will compress more for the same load).

Which change will **not** have the desired effect?

- A using more layers of springs
  - B using more springs per unit area
  - C using springs with a smaller spring constant
  - D using springs made from wire with a smaller Young modulus
- 70 The Young modulus  $E$  can be determined from measurements made when a wire is stretched.

Which quantities would be measured in order to determine  $E$ ? 9702/13/M/J/11/Q20

<b>A</b>	mass of stretching load	original length of wire	diameter of wire	extension of wire
<b>B</b>	mass of stretching load	new length of wire	cross-sectional area of wire	diameter of wire
<b>C</b>	mass of wire	original length of wire	cross-sectional area of wire	new length of wire
<b>D</b>	mass of wire	new length of wire	diameter of wire	extension of wire

- 71 The Young modulus of steel is determined using a length of steel wire and is found to have the value  $E$ . 9702/11/O/N/11/Q23

Another experiment is carried out using a wire of the same steel, but of half the length and half the diameter.

What value is obtained for the Young modulus in the second experiment?

- A  $\frac{1}{2}E$
- B  $E$
- C  $2E$
- D  $4E$



- 72 A rubber band is stretched and then relaxed to its original length. The diagram shows the force-extension graph for this process. 9702/11/O/N/11/Q24

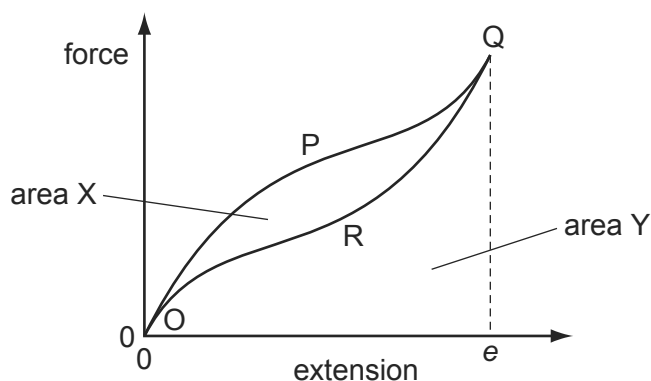

As the force is increased, the curve follows the path OPQ to extension  $e$ . As the force is reduced, the curve follows the path QRO to return to zero extension.

The area labelled X is between the curves OPQ and QRO. The area labelled Y is bounded by the curve QRO and the horizontal axis.

Which statement about the process is correct?

- A Area X is the energy which heats the band as it is stretched to  $e$ .
  - B (Area X + area Y) is the minimum energy required to stretch the band to  $e$ .
  - C Area X is the elastic potential energy stored in the band when it is stretched to  $e$ .
  - D (Area Y – area X) is the net work done on the band during the process.
- 73 When describing the behaviour of a spring, the spring constant is used. 9702/11/O/N/11/Q25

Different loads are used to extend the spring by different amounts.

To find the spring constant, which quantities are required?

- A the elastic limit and the loads
  - B the elastic limit, extensions and the length of the spring
  - C the loads and the extensions of the spring
  - D the loads and the length of the spring
- 74 The Young modulus of steel is determined using a length of steel wire and is found to have the value  $E$ .

Another experiment is carried out using a wire of the same steel, but of half the length and half the diameter.

What value is obtained for the Young modulus in the second experiment? 9702/13/O/N/11/Q21

- A  $\frac{1}{2}E$
- B  $E$
- C  $2E$
- D  $4E$

- 75 A metal cube of side  $l$  is placed in a vice and compressed elastically by two opposing forces  $F$ .

9702/11/O/N/11/Q26

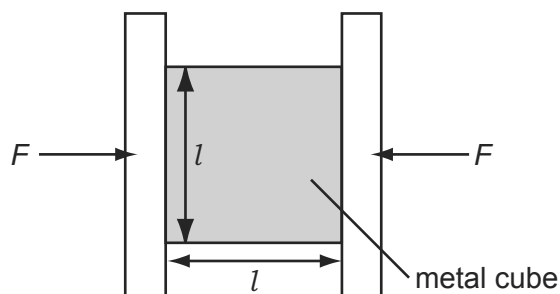

How will  $\Delta l$ , the amount of compression, relate to  $l$ ?

- A**  $\Delta l \propto \frac{1}{l^2}$       **B**  $\Delta l \propto \frac{1}{l}$       **C**  $\Delta l \propto l$       **D**  $\Delta l \propto l^2$
- 76 The graph shows the relationship between stress and strain for three wires of the same linear dimensions but made from different materials. 9702/12/O/N/11/Q21

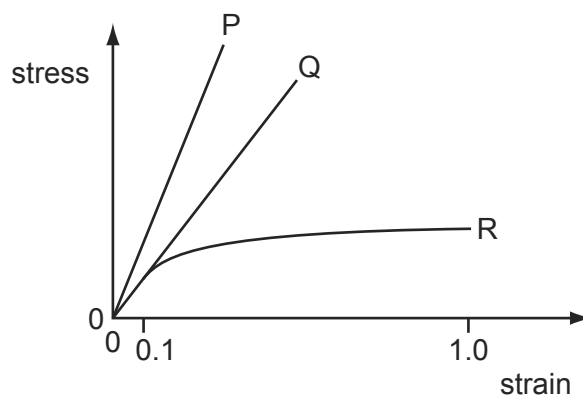

Which statements are correct?

- 1 The extension of P is approximately twice that of Q for the same stress.
- 2 The ratio of the Young modulus for P to that of Q is approximately two.
- 3 For strain less than 0.1, R obeys Hooke's law.

- A** 1, 2 and 3      **B** 1 and 3 only      **C** 2 and 3 only      **D** 2 only

- 77 Which property of a metal wire depends on its Young modulus?

9702/13/M/J/12/Q22

- A** ductility  
**B** elastic limit  
**C** spring constant  
**D** ultimate tensile stress

78 The graph shows the effect of applying a force of up to 5 N to a spring.

9702/12/O/N/11/Q22

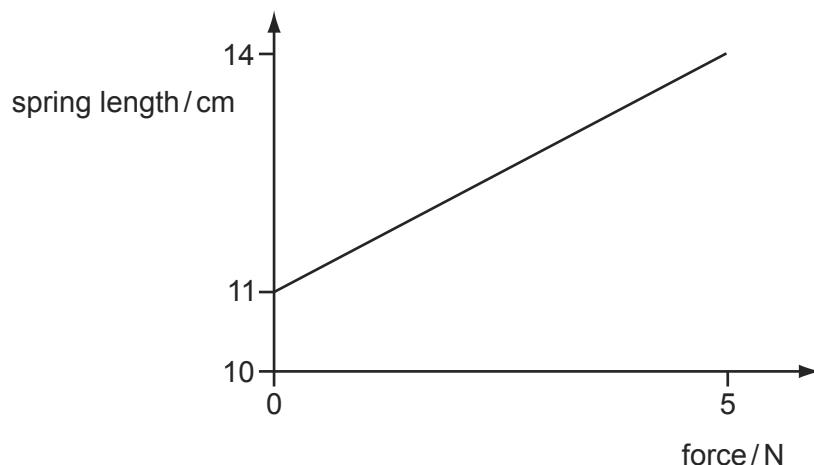

What is the total increase in length produced by a 7 N force, assuming the spring obeys Hooke's law?

- A** 4.2 cm      **B** 5.6 cm      **C** 15.2 cm      **D** 19.6 cm

79 The following force-extension graphs are drawn to the same scale.

9702/12/O/N/11/Q23

Which graph represents the deformed object with the greatest amount of elastic potential energy?

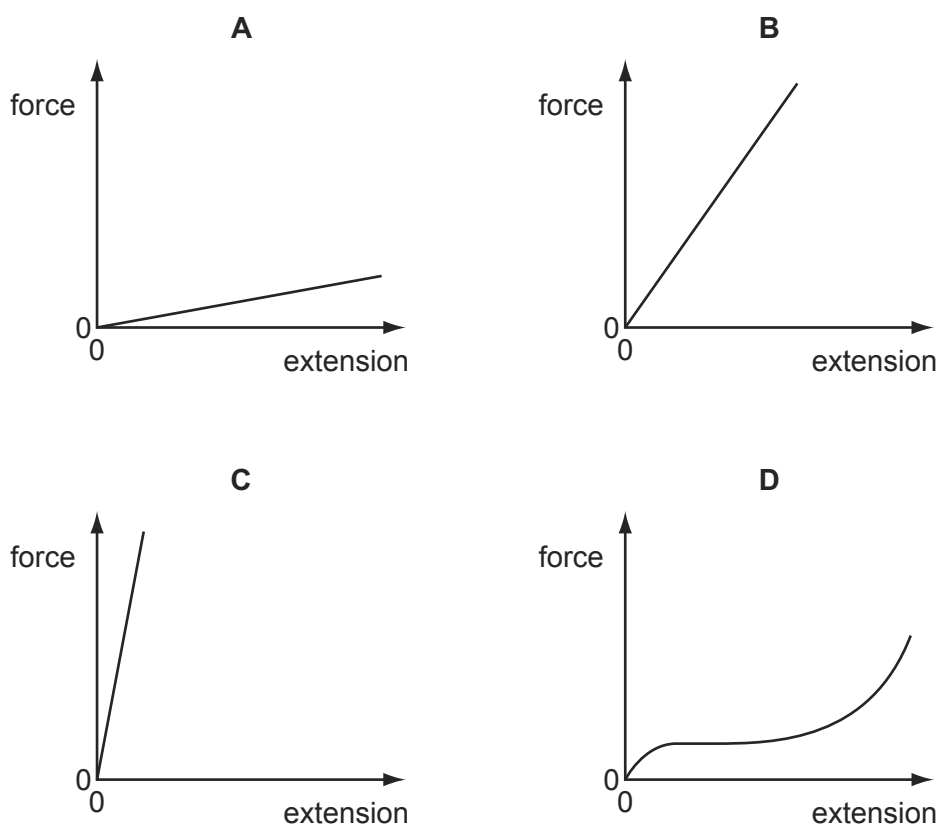

- 80 A rubber band is stretched and then relaxed to its original length. The diagram shows the force-extension graph for this process. 9702/13/O/N/11/Q22

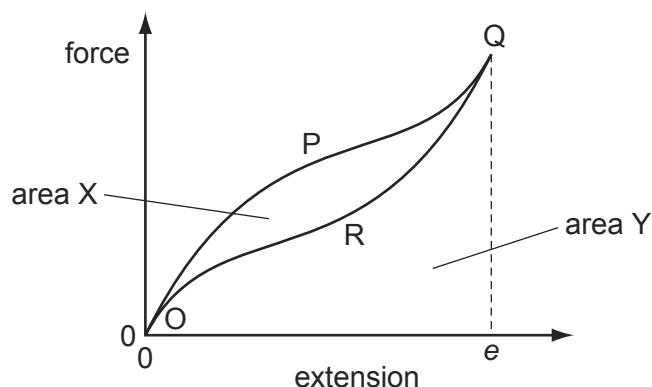

As the force is increased, the curve follows the path OPQ to extension  $e$ . As the force is reduced, the curve follows the path QRO to return to zero extension.

The area labelled X is between the curves OPQ and QRO. The area labelled Y is bounded by the curve QRO and the horizontal axis.

Which statement about the process is correct?

- A Area X is the energy which heats the band as it is stretched to  $e$ .
  - B (Area X + area Y) is the minimum energy required to stretch the band to  $e$ .
  - C Area X is the elastic potential energy stored in the band when it is stretched to  $e$ .
  - D (Area Y – area X) is the net work done on the band during the process.
- 81 Which property of a metal wire depends on its Young modulus? 9702/11/M/J/12/Q23
- A ductility
  - B elastic limit
  - C spring constant
  - D ultimate tensile stress
- 82 What is represented by the gradient of a graph of force (vertical axis) against extension (horizontal axis)? 9702/11/M/J/12/Q25
- A elastic limit
  - B spring constant
  - C stress
  - D Young modulus

- 83 The diagram shows a wire of diameter  $D$  and length  $L$  that is firmly clamped at one end between two blocks of wood. A load is applied to the wire which causes it to extend by an amount  $x$ .

9702/11/M/J/12/Q24

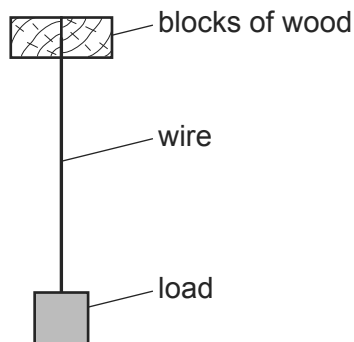

By how much would a wire of the same material, but of diameter  $2D$  and length  $3L$ , extend when the same load is applied?

- A**  $\frac{2}{3}x$       **B**  $\frac{3}{4}x$       **C**  $\frac{4}{3}x$       **D**  $\frac{3}{2}x$
- 84 The graph is a force-extension graph for a wire that is being stretched.

9702/12/M/J/12/Q24

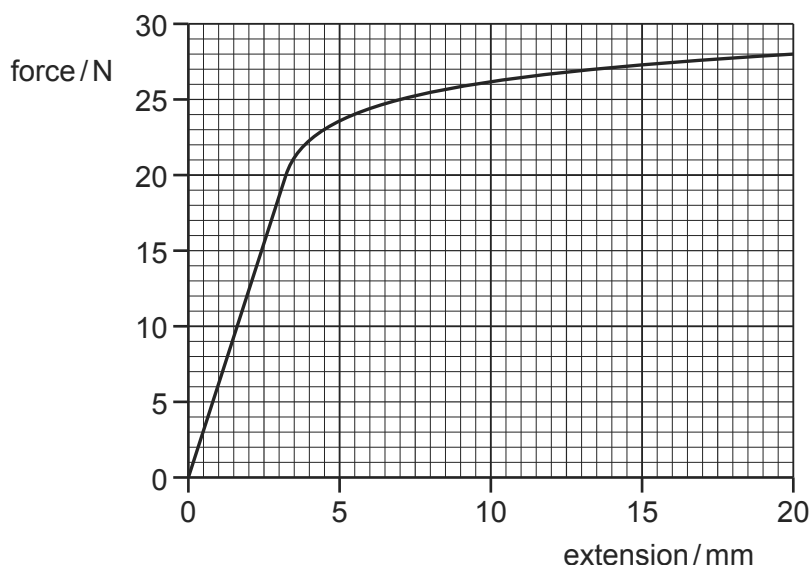

How much work needs to be done by the tensile force, to two significant figures, to cause an extension of 7.0 mm?

- A** 0.088 J      **B** 0.12 J      **C** 0.53 J      **D** 120 J
- 85 A wire stretches 8 mm under a load of 60 N.
- A second wire of the same material, with half the diameter and a quarter of the original length of the first wire, is stretched by the same load.

9702/12/M/J/12/Q25

Assuming that Hooke's law is obeyed, what is the extension of this wire?

- A** 1 mm      **B** 4 mm      **C** 8 mm      **D** 16 mm

- 86 What is represented by the gradient of a graph of force (vertical axis) against extension (horizontal axis)?

9702/13/M/J/12/Q20

- A elastic limit
- B spring constant
- C stress
- D Young modulus

- 87 The diagram shows a wire of diameter  $D$  and length  $L$  that is firmly clamped at one end between two blocks of wood. A load is applied to the wire which causes it to extend by an amount  $x$ .

9702/13/M/J/12/Q21

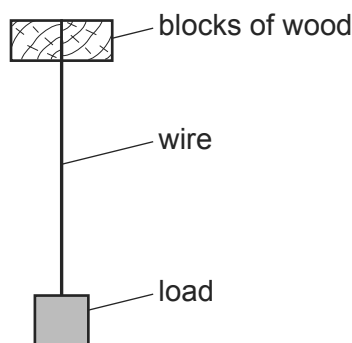

By how much would a wire of the same material, but of diameter  $2D$  and length  $3L$ , extend when the same load is applied?

- A  $\frac{2}{3}x$
  - B  $\frac{3}{4}x$
  - C  $\frac{4}{3}x$
  - D  $\frac{3}{2}x$
- 88 The diagram shows the force-extension graphs for two materials, of the same dimensions, loaded to fracture.

9702/12/O/N/12/Q26

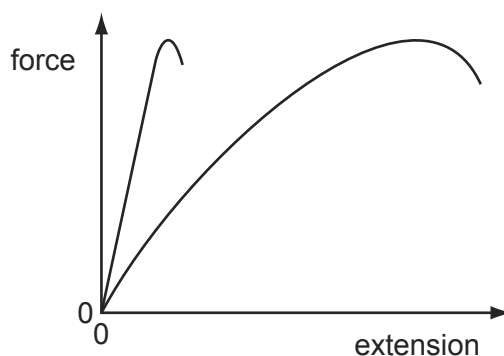

What describes the behaviour of the materials?

- A Both materials are brittle.
- B Both materials obey Hooke's law.
- C Both materials are plastic.
- D Both materials have the same ultimate tensile stress.

- 89 What leads to the conclusion that the movement of molecules is random? 9702/12/O/N/12/Q25
- A** evaporation of water at room temperature  
**B** conduction of electricity in water  
**C** convection currents in air  
**D** motion of dust particles in air

- 90 Two wires, X and Y, are made from different metals and have different dimensions. The Young modulus of wire X is twice that of wire Y. The diameter of wire X is half that of wire Y. 9702/12/O/N/12/Q27

Both wires are extended with equal strain and obey Hooke's law.

What is the ratio  $\frac{\text{tension in wire X}}{\text{tension in wire Y}}$  ?

- A**  $\frac{1}{8}$                       **B**  $\frac{1}{2}$                       **C** 1                      **D** 8
- 91 The diagram shows two identical loudspeakers driven in phase by a common audio-frequency source. 9702/12/O/N/12/Q28

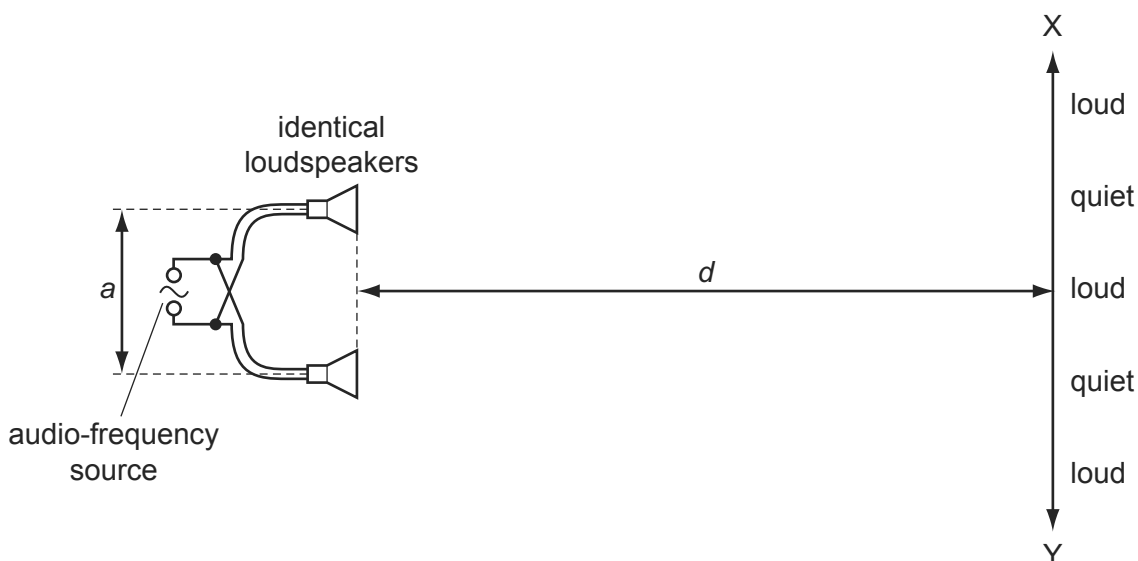

When a student moves along line  $XY$ , she notices that there are variations in the loudness of the sound. The regions in which the sound is heard are alternately loud and quiet as indicated on the diagram.

How may the distance between loud regions be reduced?

- A** decreasing the distance  $a$  between the speakers  
**B** increasing distance  $d$   
**C** increasing the frequency of the audio-frequency source  
**D** increasing the power output from the audio-frequency source

- 92 Three springs are arranged vertically as shown.

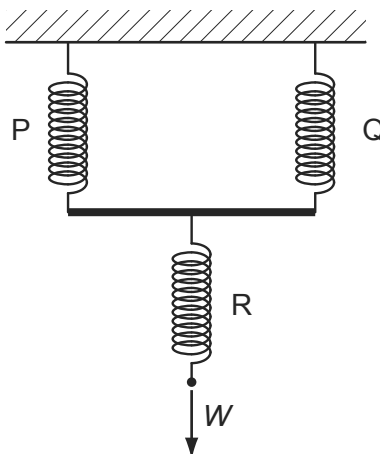

Springs P and Q are identical and have spring constant  $k$ . Spring R has spring constant  $3k$ .

What is the increase in the overall length of the arrangement when a force  $W$  is applied as shown?

- A  $\frac{5W}{6k}$       B  $\frac{4W}{3k}$       C  $\frac{7}{2}kW$       D  $4kW$
- 93 The diagram shows the stress-strain graph for two wires X and Y of different materials up to their breaking points. Both wires have the same initial dimensions.

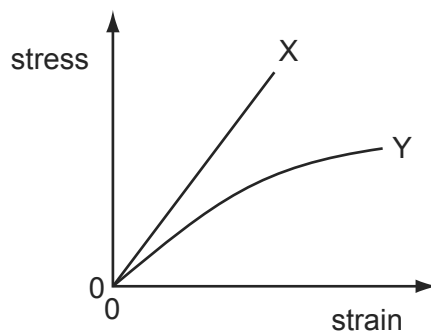

Which statement is **not** correct?

- A Material X extends elastically.  
 B Material X extends more than material Y when loaded with the same force.  
 C Material X has a larger ultimate tensile stress.  
 D Material X is brittle.



- 94 A steel wire and a brass wire are joined end to end and are hung vertically with the steel wire attached to a point on the ceiling. The steel wire is twice as long as the brass wire and has half the diameter.

9702/11/O/N/12/Q25

A large mass is hung from the end of the brass wire so that both wires are stretched elastically.

The Young modulus for steel is  $2.0 \times 10^{11}$  Pa and for brass is  $1.0 \times 10^{11}$  Pa.

What is the ratio of the extension of the steel to the extension of the brass?

- A** 2                      **B** 4                      **C** 8                      **D** 16

- 95 A trolley is held at rest between two steel springs.

9702/13/O/N/12/Q24

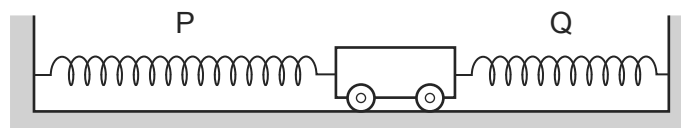

Each spring has an unstretched length of 0.10 m.

Spring P has spring constant  $60 \text{ N m}^{-1}$ .  
Spring Q has spring constant  $120 \text{ N m}^{-1}$ .

Spring P has an extension of 0.40 m.

What is the extension of spring Q?

- A** 0.10 m              **B** 0.20 m              **C** 0.30 m              **D** 0.80 m

- 96 A lift is supported by two steel cables, each of length 10 m and diameter 0.5 cm.

9702/13/O/N/12/Q25

The lift drops 1 mm when a man of mass 80 kg steps into the lift.

What is the best estimate of the value of the Young modulus of the steel?

- A**  $2 \times 10^{10} \text{ N m}^{-2}$   
**B**  $4 \times 10^{10} \text{ N m}^{-2}$   
**C**  $2 \times 10^{11} \text{ N m}^{-2}$   
**D**  $4 \times 10^{11} \text{ N m}^{-2}$

97 The stress-strain graphs for four different materials are shown below.

9702/11/M/J/13/Q22

Which diagram shows the stress-strain graph for a ductile metal?

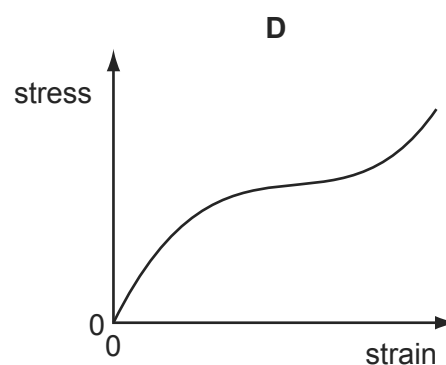
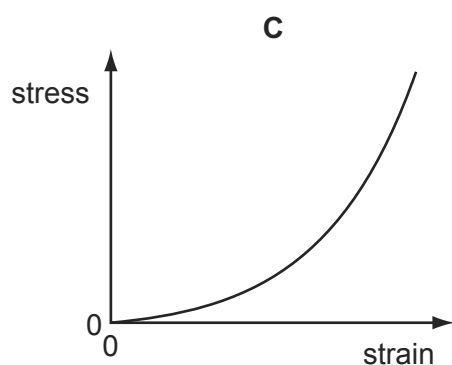
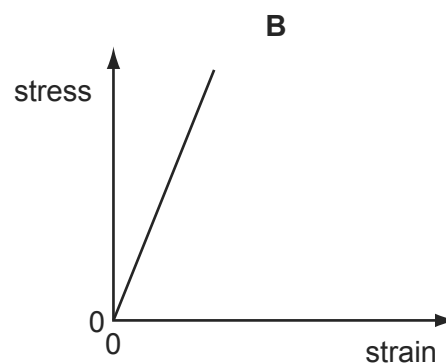
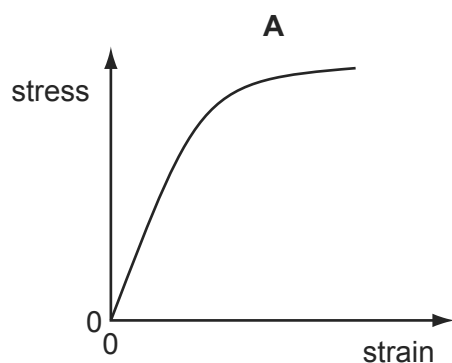

98 A number of identical springs, each having the same spring constant, are joined in four arrangements. A different load is applied to each arrangement.

9702/11/M/J/13/Q23

Which arrangement has the largest extension?

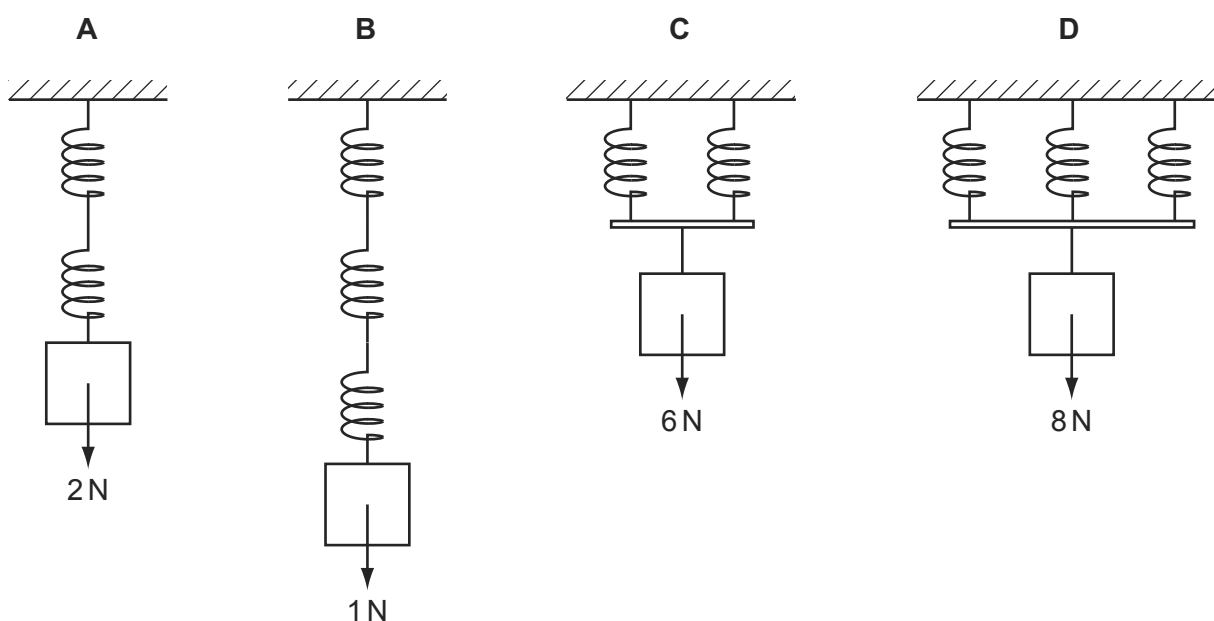

- 99 A rubber cord hangs from a rigid support. A weight attached to its lower end is gradually increased from zero, and then gradually reduced to zero.

9702/12/M/J/13/Q22

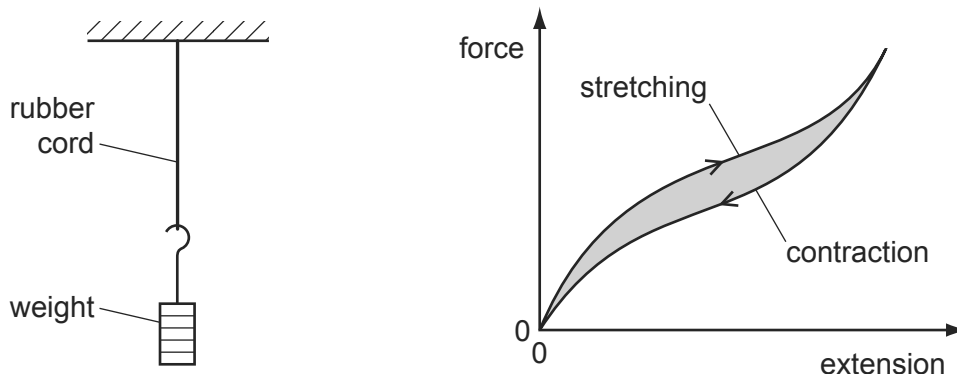

The force-extension curve for contraction is below the force-extension curve for stretching.

What does the shaded area between the curves represent?

- A the amount of elastic energy stored in the rubber
  - B the amount of thermal energy dissipated in the rubber
  - C the work done on the rubber cord during stretching
  - D the work done by the rubber cord during contraction
- 100 The diagram shows a large crane on a construction site lifting a cube-shaped load. 9702/12/M/J/13/Q23

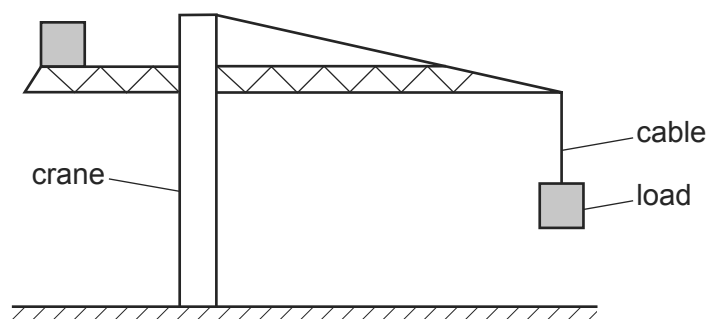

A model is made of the crane, its load and the cable supporting the load.

The material used for each part of the model is the same as that in the full-size crane, cable and load. The model is one tenth full-size in all linear dimensions.

What is the ratio  $\frac{\text{stress in the cable on the full-size crane}}{\text{stress in the cable on the model crane}}$  ?

- A  $10^0$
  - B  $10^1$
  - C  $10^2$
  - D  $10^3$
- 101 What is the unit of the Young modulus? 9702/12/M/J/13/Q21

- A  $\text{Nm}^{-1}$
- B  $\text{Nm}$
- C  $\text{Nm}^{-2}$
- D  $\text{Nm}^2$

- 102 The diagram shows a large crane on a construction site lifting a cube-shaped load. 9702/13/M/J/13/Q19

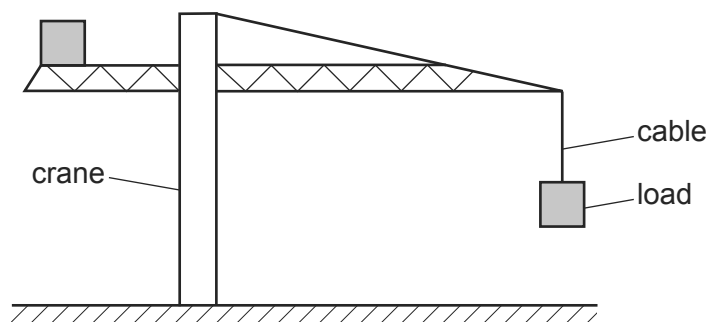

A model is made of the crane, its load and the cable supporting the load.

The material used for each part of the model is the same as that in the full-size crane, cable and load. The model is one tenth full-size in all linear dimensions.

What is the ratio  $\frac{\text{extension of the cable on the full-size crane}}{\text{extension of the cable on the model crane}}$  ?

- A**  $10^0$       **B**  $10^1$       **C**  $10^2$       **D**  $10^3$
- 103 Which graph represents the force-extension relationship of a rubber band that is stretched almost to its breaking point? 9702/13/M/J/13/Q20

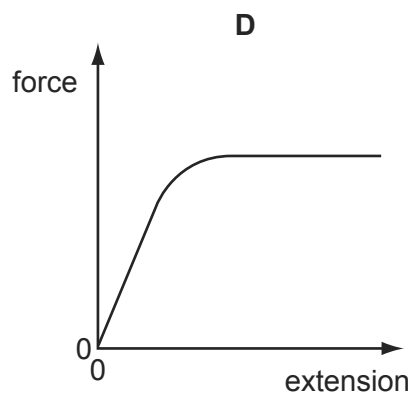
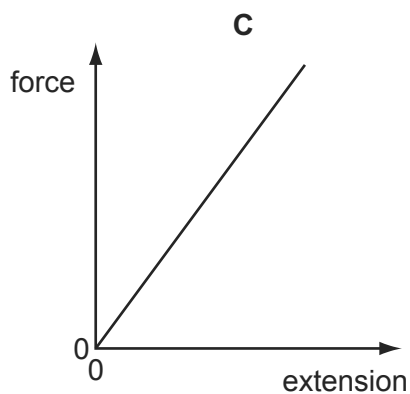
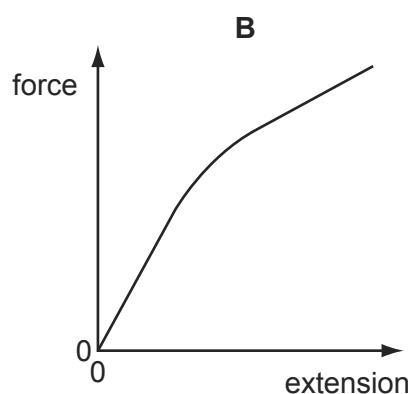
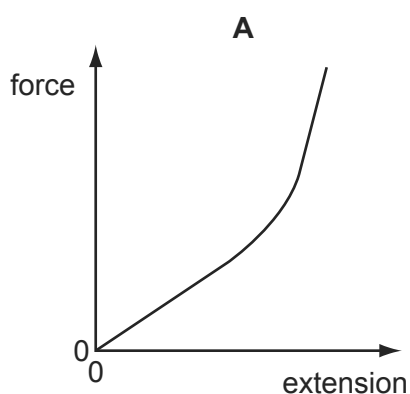

- 104 A spring is stretched over a range within which elastic deformation occurs. Its spring constant is  $3.0 \text{ N cm}^{-1}$ . 9702/13/M/J/13/Q21

Which row, for the stated applied force, gives the correct extension and strain energy?

	force /N	extension /cm	strain energy /mJ
<b>A</b>	3.0	1.0	1.5
<b>B</b>	6.0	2.0	120
<b>C</b>	12.0	3.0	180
<b>D</b>	24.0	8.0	960

- 105 A spring of unextended length 40 mm is suspended from a fixed point. A load of 16 N is applied to the free end of the spring. This causes the spring to extend so that its final length is five times its original length. The spring obeys Hooke's Law. 9702/13/M/J/13/Q15

What is the energy stored in the spring due to this extension?

- A** 1.3 J      **B** 1.6 J      **C** 2.6 J      **D** 3.2 J

- 106 Which properties best describe modelling clay? 9702/11/O/N/13/Q23

- A** brittle and ductile  
**B** ductile and elastic  
**C** elastic and plastic  
**D** plastic and ductile

- 107 A steel spring has a spring constant of  $150 \text{ N m}^{-1}$ . When a 25 N weight is hung from the spring, it has a stretched length of 55 cm. 9702/11/O/N/13/Q24

What was the original length of the spring?

- A** 0.38 m      **B** 0.49 m      **C** 0.61 m      **D** 0.72 m

- 108 A lift is supported by two steel cables each of length 20 m. 9702/13/O/N/13/Q22

Each of the cables consists of 100 parallel steel wires, each wire of cross-sectional area  $3.2 \times 10^{-6} \text{ m}^2$ . The Young modulus of steel is  $2.1 \times 10^{11} \text{ N m}^{-2}$ .

Which distance does the lift move downward when a man of mass 70 kg steps into it?

- A** 0.010 mm      **B** 0.020 mm      **C** 0.10 mm      **D** 0.20 mm

109 The stress-strain graphs for three different materials are shown, not drawn to the same scales.

9702/11/M/J/14/Q20

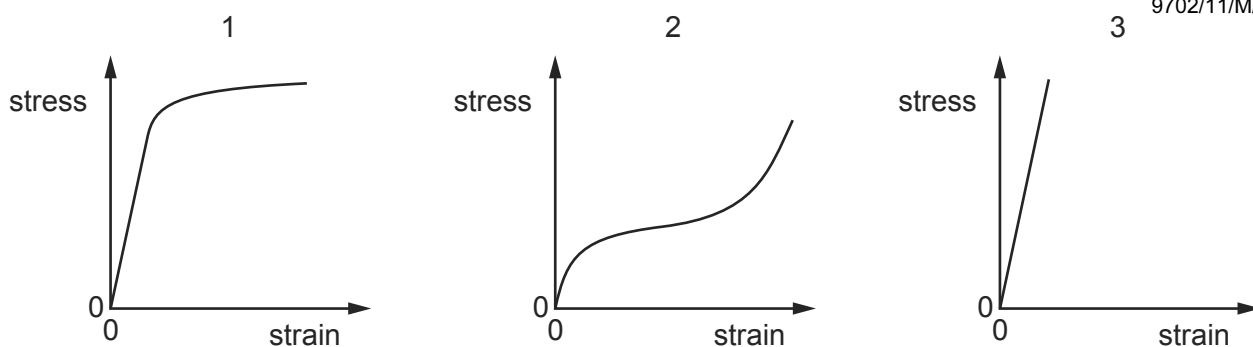

The three materials are copper, rubber and glass.

Which materials are represented by the graphs?

	1	2	3
A	copper	glass	rubber
B	copper	rubber	glass
C	glass	copper	rubber
D	glass	rubber	copper

110 The graph is a load-extension graph for a wire undergoing elastic deformation.

9702/11/M/J/14/Q21

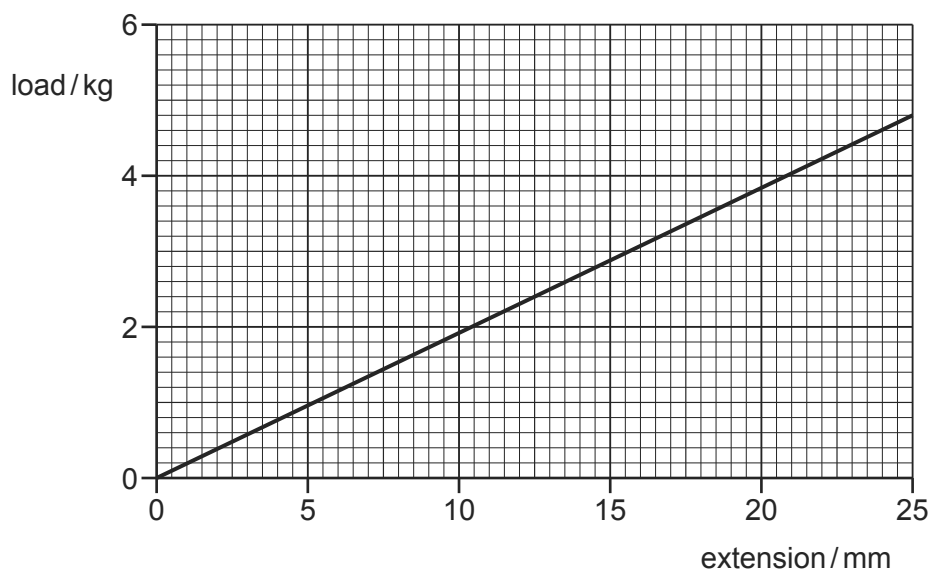

How much work is done on the wire to increase the extension from 10 mm to 20 mm?

- A** 0.028 J      **B** 0.184 J      **C** 0.28 J      **D** 0.37 J

- 111 What is equal to the Young modulus of a material that is extended elastically within the limit of proportionality?  
9702/13/O/N/13/Q23
- A** area under the force-extension graph  
**B** area under the stress-strain graph  
**C** gradient of the force-extension graph  
**D** gradient of the stress-strain graph
- 112 A sample of metal is subjected to a force which increases to a maximum value and then decreases back to zero. A force-extension graph for the sample is shown.  
9702/12/M/J/14/Q19

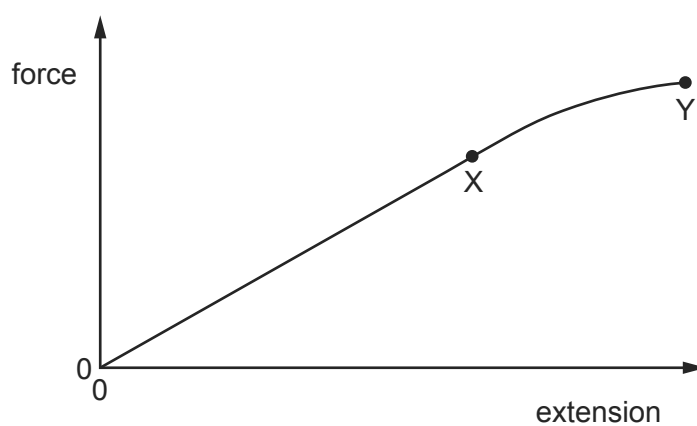

When the sample contracts it follows the same force-extension curve as when it was being stretched.

What is the behaviour of the metal between X and Y?

- A** both elastic and plastic  
**B** not elastic and not plastic  
**C** plastic but not elastic  
**D** elastic but not plastic
- 113 An elastic material with a Young modulus  $E$  is subjected to a tensile stress  $S$ . Hooke's Law is obeyed.  
9702/13/M/J/14/Q23

What is the expression for the elastic energy stored per unit volume of the material?

- A**  $\frac{S^2}{2E}$       **B**  $\frac{S^2}{E}$       **C**  $\frac{E}{2S^2}$       **D**  $\frac{2E}{S^2}$

114 The graph shows the length of a spring as it is stretched by an increasing load.

9702/12/M/J/14/Q20

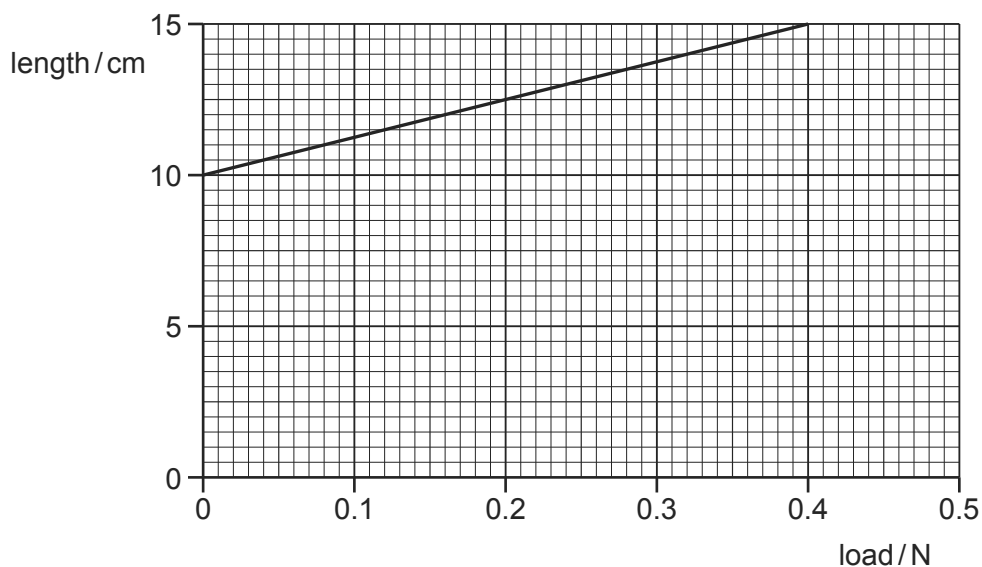

What is the spring constant?

- A**  $8.0 \text{ Nm}^{-1}$       **B**  $2.7 \text{ Nm}^{-1}$       **C**  $0.13 \text{ Nm}^{-1}$       **D**  $0.080 \text{ Nm}^{-1}$

115 A composite rod is made by attaching a glass-reinforced plastic rod and a nylon rod end to end, as shown.

9702/12/M/J/14/Q21

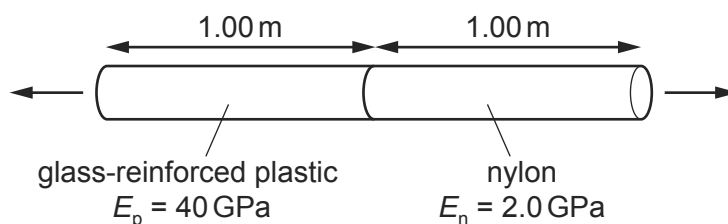

The rods have the same cross-sectional area and each rod is 1.00 m in length. The Young modulus  $E_p$  of the plastic is 40 GPa and the Young modulus  $E_n$  of the nylon is 2.0 GPa.

The composite rod will break when its total extension reaches 3.0 mm.

What is the greatest tensile stress that can be applied to the composite rod before it breaks?

- A**  $7.1 \times 10^{-14} \text{ Pa}$   
**B**  $7.1 \times 10^{-2} \text{ Pa}$   
**C**  $5.7 \times 10^6 \text{ Pa}$   
**D**  $5.7 \times 10^9 \text{ Pa}$

116 The Mariana Trench in the Pacific Ocean has a depth of about 10 km.

9702/13/M/J/14/Q22

Assuming that sea water is incompressible and has a density of about  $1020 \text{ kg m}^{-3}$ , what would be the approximate pressure at that depth?

- A**  $10^5 \text{ Pa}$       **B**  $10^6 \text{ Pa}$       **C**  $10^7 \text{ Pa}$       **D**  $10^8 \text{ Pa}$



- 117 Cylindrical samples of steel, glass and rubber are each subjected to a gradually increasing tensile force  $F$ . The extensions  $e$  are measured and graphs are plotted as shown below. 9702/13/M/J/14/Q24

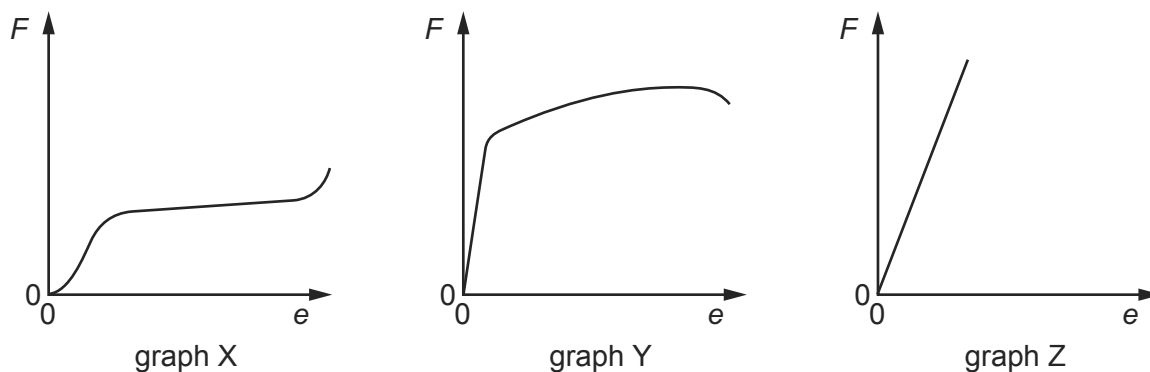

Which row correctly relates the graphs to the materials?

	steel	glass	rubber
<b>A</b>	X	Y	Z
<b>B</b>	X	Z	Y
<b>C</b>	Y	X	Z
<b>D</b>	Y	Z	X

- 118 The graph shows the behaviour of a sample of a metal when it is stretched until it starts to undergo plastic deformation. 9702/13/O/N/14/Q24

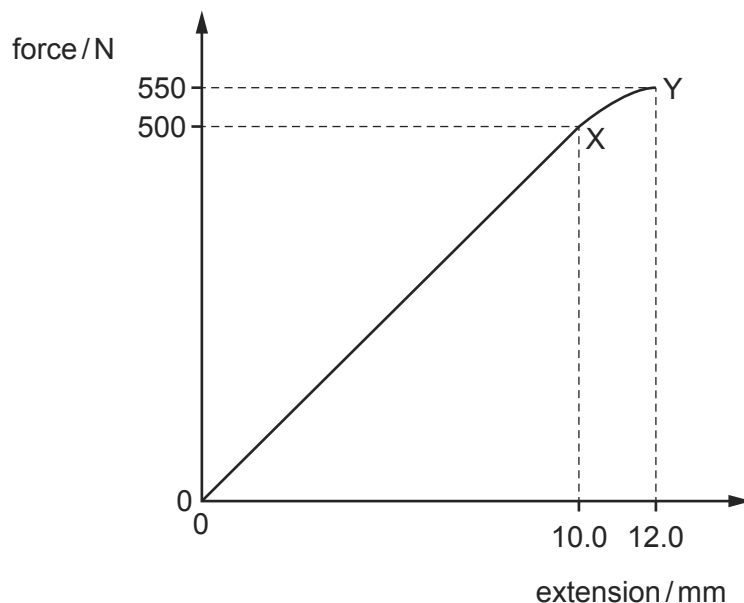

What is the total work done in stretching the sample from zero to 12.0 mm extension? Simplify the calculation by treating the curve XY as a straight line.

- A** 3.30 J                      **B** 3.55 J                      **C** 3.60 J                      **D** 6.60 J

119 What is meant by the ultimate tensile stress of a material?

9702/13/O/N/14/Q23

- A** the maximum force that can be applied to a bar of the material before it bends
- B** the maximum inter-atomic force before the atomic bonds of the material break
- C** the maximum stretching force per unit cross-sectional area before the material breaks
- D** the maximum tensile force in a wire of the material before it breaks

120 Two springs, one with spring constant  $k_1 = 4 \text{ kNm}^{-1}$  and the other with spring constant  $k_2 = 2 \text{ kNm}^{-1}$ , are connected as shown.

9702/13/O/N/14/Q25

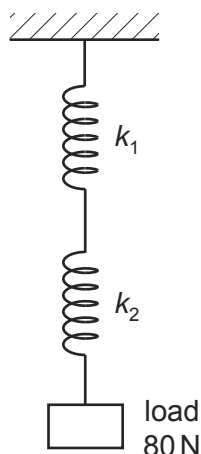

What is the total extension of the springs when supporting a load of 80 N?

- A** 1.3 cm
- B** 4 cm
- C** 6 cm
- D** 60 cm

121 The stress-strain graph for a glass rod, up to the point at which it breaks, is shown below.

9702/11/O/N/14/Q20

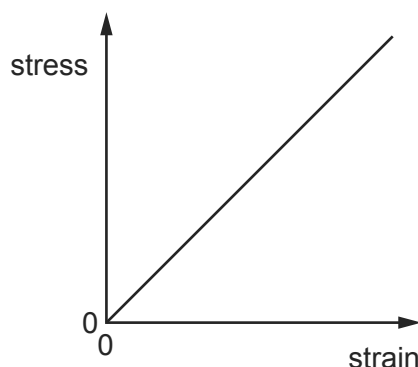

Which statement about the glass rod is correct?

- A** Hooke's law is obeyed for all values of stress up to the breaking point.
- B** The glass is ductile.
- C** The glass shows plastic deformation.
- D** When the cross-sectional area of the rod is doubled, the ultimate tensile stress of the rod is halved.

122 A steel bar of circular cross-section is under tension  $T$ , as shown.

9702/13/M/J/15/Q22

The diameter of the wide portion is double the diameter of the narrow portion.

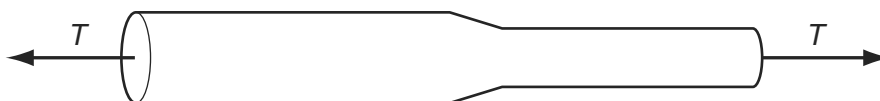

What is the value of  $\frac{\text{stress in the wide portion}}{\text{stress in the narrow portion}}$  ?

- A** 0.25      **B** 0.50      **C** 2.0      **D** 4.0

123 A rubber band is stretched by hanging weights on it and the force-extension graph is plotted from the results.

9702/11/O/N/14/Q21

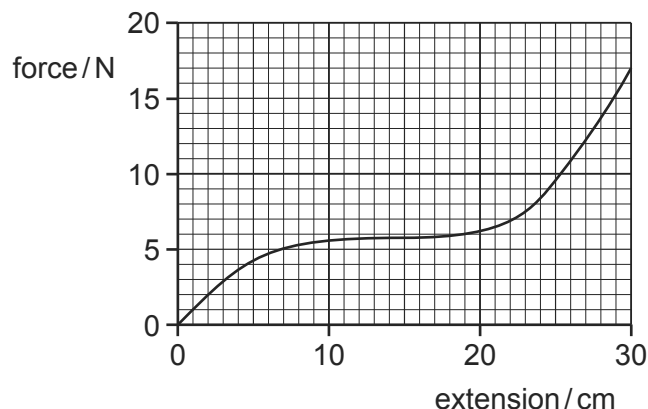

What is the best estimate of the strain energy stored in the rubber band when it is extended 30 cm?

- A** 1.8 J      **B** 2.6 J      **C** 5.1 J      **D** 200 J

124 To determine the Young modulus of a wire, several measurements are taken.

9702/12/M/J/15/Q21

In which row can the measurement **not** be taken **directly** with the stated apparatus?

	measurement	apparatus
<b>A</b>	area of cross-section of wire	micrometer screw gauge
<b>B</b>	extension of wire	vernier scale
<b>C</b>	mass of load applied to wire	electronic balance
<b>D</b>	original length of wire	metre rule

- 125 The graph shows the non-linear force-extension curve for a wire made from a new composite material.

9702/13/M/J/15/Q23

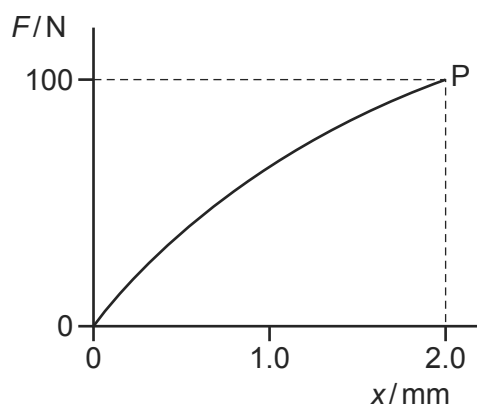

What could be the value of the strain energy stored in the wire when it is stretched elastically to point P?

- A** 0.09J      **B** 0.10J      **C** 0.11J      **D** 0.20J

- 126 The diagram shows the stress-strain graph for bone.

9702/13/M/J/15/Q24

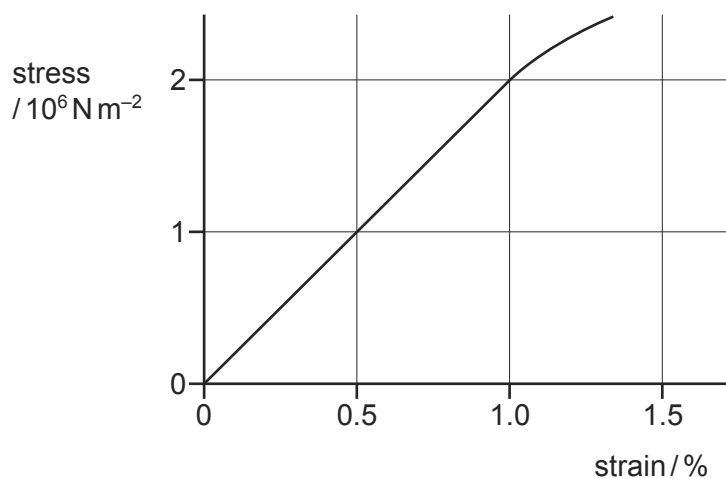

What is the Young modulus of bone?

- A**  $1 \times 10^6 \text{ Nm}^{-2}$   
**B**  $2 \times 10^6 \text{ Nm}^{-2}$   
**C**  $1 \times 10^8 \text{ Nm}^{-2}$   
**D**  $2 \times 10^8 \text{ Nm}^{-2}$

- 127 A long, thin metal wire is suspended from a fixed support and hangs vertically. Masses are suspended from its lower end.

9702/12/M/J/15/Q22

The load on the lower end is increased from zero and then decreased again back to zero.

The diagram shows the force-extension graph produced.

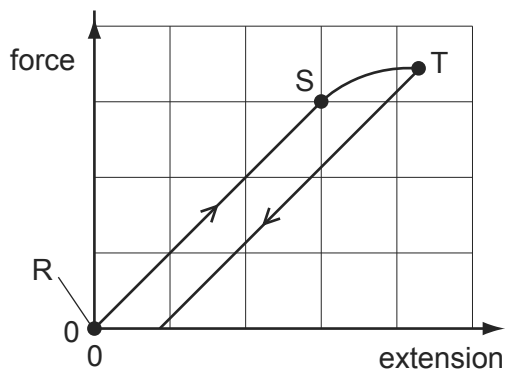

Where on the graph would the elastic limit be found?

- A** anywhere between point R and point S  
**B** just beyond point S  
**C** exactly at point S  
**D** exactly at point T
- 128 The graph shown was plotted in an experiment on a metal wire.

9702/11/M/J/15/Q22

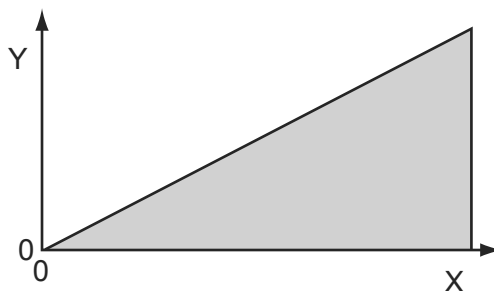

The shaded area represents the total strain energy stored in stretching the wire.

How should the axes be labelled?

	Y	X
<b>A</b>	force	extension
<b>B</b>	mass	extension
<b>C</b>	strain	energy
<b>D</b>	stress	strain

- 129 The diagram represents a steel tube with wall thickness  $w$  which is small in comparison with the diameter of the tube.

9702/12/M/J/15/Q23

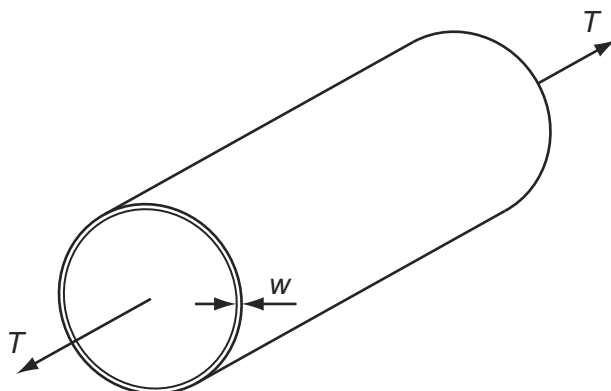

The tube is under tension, caused by a force  $T$ , parallel to the axis of the tube. To reduce the stress in the material of the tube, it is proposed to thicken the wall.

The tube diameter and the tension being constant, which wall thickness gives half the stress?

- A  $\frac{w}{2}$       B  $\sqrt{2}w$       C  $2w$       D  $4w$

- 130 The variation with applied force of the extension of a spring is shown in the graph.

9702/11/M/J/15/Q23

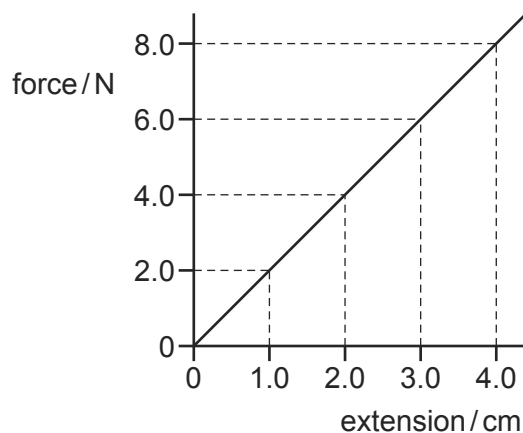

When there is no force applied to the spring, it has a length of 1.0 cm.

What is the **increase** in the strain energy stored in the spring when its **length** is increased from 2.0 cm to 3.0 cm?

- A 0.020 J      B 0.030 J      C 0.040 J      D 0.050 J

20 For a given liquid at atmospheric pressure, which process can occur at any temperature?

9702/1/M/J/02

- A boiling
- B evaporation
- C melting
- D solidification

21 A mass of a liquid of density  $\rho$  is thoroughly mixed with an equal mass of another liquid of density  $2\rho$ . No change of the total volume occurs.

What is the density of the liquid mixture?

9702/1/M/J/02

- A  $\frac{4}{3}\rho$       B  $\frac{3}{2}\rho$       C  $\frac{5}{3}\rho$       D  $3\rho$

20 Pollen grains are suspended in a liquid and are illuminated strongly. When observed under a microscope they are seen to be in continuous random motion.

What is the reason for this?

9702/1/O/N/02

- A convection currents in the liquid
- B evaporation of the liquid
- C molecules of the liquid colliding with the pollen grains
- D pollen grains colliding with each other

21 At a depth of 20 cm in a liquid of density  $1800 \text{ kg m}^{-3}$ , the pressure due to the liquid is  $p$ .

Another liquid has a density of  $1200 \text{ kg m}^{-3}$ .

9702/1/O/N/02

What is the pressure due to this liquid at a depth of 60 cm?

- A  $\frac{p}{2}$       B  $\frac{3p}{2}$       C  $2p$       D  $3p$

22 Which line in the table gives approximate ratios of density and molecular spacing for a substance in its solid, liquid and gas phases?

9702/1/O/N/02

	density	molecular spacing
	solid : liquid : gas	solid : liquid : gas
A	1000 : 1000 : 1	1 : 1 : 10
B	1000 : 100 : 1	1 : 10 : 1000
C	1000 : 1000 : 1	1 : 1 : 1000
D	1000 : 100 : 1	1 : 10 : 100

- 20 A child drinks a liquid of density  $\rho$  through a vertical straw.

Atmospheric pressure is  $p_0$  and the child is capable of lowering the pressure at the top of the straw by 10%. The acceleration of free fall is  $g$ .

What is the maximum length of straw that would enable the child to drink the liquid?

9702/01/M/J/03

- A  $\frac{p_0}{10\rho g}$       B  $\frac{9p_0}{10\rho g}$       C  $\frac{p_0}{\rho g}$       D  $\frac{10p_0}{\rho g}$

- 19 The graph shows how the pressure exerted by a liquid varies with depth below the surface.

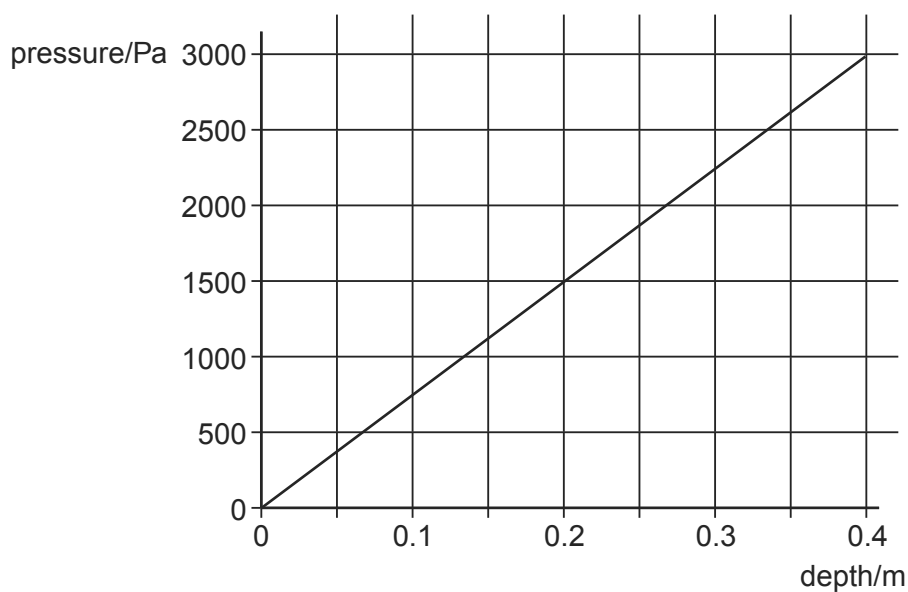

9702/01/O/N/03

What is the density of the liquid?

- A  $600 \text{ kg m}^{-3}$       B  $760 \text{ kg m}^{-3}$       C  $5900 \text{ kg m}^{-3}$       D  $7500 \text{ kg m}^{-3}$
- 20 In an experiment to demonstrate Brownian motion, smoke particles in a container are illuminated by a strong light source and observed through a microscope.

The particles are seen as small specks of light that are in motion.

9702/01/O/N/03

What causes this motion?

- A collisions between the smoke particles and air molecules  
 B collisions between the smoke particles and the walls of the container  
 C convection currents within the air as it is warmed by the light source  
 D kinetic energy gained by the smoke particles on absorption of light



19 Comparing the properties of solids, liquids and gases, which option is correct?

	property	solids	liquids	gases
<b>A</b>	ordering of molecules	high	not so high	random
<b>B</b>	spacing of molecules	close	far	far
<b>C</b>	translation of molecules	no	no	yes
<b>D</b>	vibration of molecules	no	yes	yes

9702/01/M/J/04

20 Particles of dust, suspended in water, are viewed through a microscope. The particles can be seen to move irregularly.

This movement is due to

- A** convection currents in the water.
- B** evaporation of the water near the dust particles.
- C** gravitational forces acting on the particles of dust.
- D** water molecules hitting the dust particles in a random way.

9702/01/M/J/04

21 Two solid substances P and Q have atoms of mass  $M_P$  and  $M_Q$  respectively. They have  $N_P$  and  $N_Q$  atoms per unit volume.

It is found by experiment that the density of P is greater than that of Q.

Which of the following deductions from this experiment must be correct?

9702/01/M/J/04

- A**  $M_P > M_Q$
- B**  $N_P > N_Q$
- C**  $M_P N_P > M_Q N_Q$
- D**  $\frac{M_P}{N_P} > \frac{M_Q}{N_Q}$

19 Which statement applies to the boiling but **not** to the evaporation of a liquid?

- A** All the bonds between molecules in the liquid are broken.
- B** At normal atmospheric pressure, the process occurs at one temperature only.
- C** Energy must be provided for the process to happen.
- D** The separation of the molecules increases greatly.

9702/01/O/N/04

- 20 The diagram shows two liquids, labelled P and Q, which do **not** mix. The liquids are in equilibrium in an open U-tube.

9702/01/O/N/04

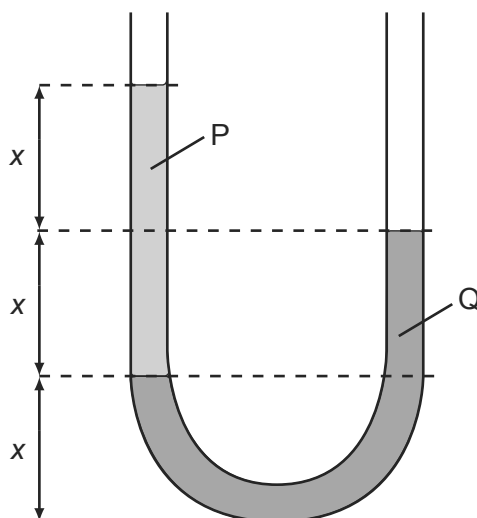

What is the ratio  $\frac{\text{density of P}}{\text{density of Q}}$ ?

- A  $\frac{1}{2}$       B  $\frac{2}{3}$       C  $\frac{3}{2}$       D 2
- 21 Which two substances are normally both crystalline?

- A copper and diamond  
 B copper and glass  
 C diamond and glass  
 D diamond and rubber

9702/01/O/N/04

- 18 The hydrostatic pressure  $p$  at a depth  $h$  in a liquid of density  $\rho$  is given by the formula  $p = h\rho g$ .

Which equation, or principle of physics, is used in the derivation of this formula? 9702/01/M/J/05

- A density = mass  $\div$  volume  
 B potential energy =  $mgh$   
 C atmospheric pressure decreases with height  
 D density increases with depth

- 17 Why does the pressure increase when a sealed container of gas is heated?

- A The gas molecules collide more often with each other.  
 B The gas molecules expand when they are heated.  
 C The gas molecules travel faster and hit the walls of the container more often.  
 D There are more gas molecules present to collide with the walls of the container.

9702/01/O/N/05

- 19 Pollen grains are suspended in a liquid and are illuminated strongly. When observed under a microscope they are seen to be in continuous random motion.

What is the reason for this?

9702/01/M/J/05

- A convection currents in the liquid
- B evaporation of the liquid
- C molecules of the liquid colliding with the pollen grains
- D pollen grains colliding with each other

- 18 Liquids X and Y are stored in large open tanks. Liquids X and Y have densities of  $800 \text{ kg m}^{-3}$  and  $1200 \text{ kg m}^{-3}$  respectively.

At what depths are the pressures equal?

9702/01/O/N/05

	depth in liquid X	depth in liquid Y
A	8 m	12 m
B	10 m	10 m
C	15 m	10 m
D	18 m	8 m

- 19 When white sugar granules are heated, they melt. When the melt is cooled quickly, a brittle solid form of toffee is produced.

How does the structure of the sugar change?

9702/01/O/N/05

- A amorphous to polymeric
- B crystalline to amorphous
- C crystalline to polymeric
- D polymeric to amorphous

- 19 Below are four short paragraphs describing the molecules in a beaker of water at  $50^\circ\text{C}$ .

Which paragraph correctly describes the molecules?

9702/01/M/J/06

- A The molecules all travel at the same speed. This speed is not large enough for any of the molecules to leave the surface of the water. There are attractive forces between the molecules.
- B The molecules have a range of speeds. Some molecules travel sufficiently fast to leave the surface of the water. There are no forces between the molecules.
- C The molecules have a range of speeds. Some molecules travel sufficiently fast to leave the surface of the water. There are attractive forces between the molecules.
- D The molecules have a range of speeds. The fastest molecules are unable to leave the surface of the water. There are attractive forces between the molecules.

- 20 In an experiment to demonstrate Brownian motion, smoke particles in a container are illuminated by a strong light source and observed through a microscope.

The particles are seen as small specks of light that are in motion.

9702/01/M/J/06

What causes the Brownian motion?

- A** collisions between the smoke particles and air molecules
- B** collisions between the smoke particles and the walls of the container
- C** convection currents within the air as it is warmed by the light source
- D** kinetic energy gained by the smoke particles on absorption of light
- 19 Which statement defines the density of a substance?
- A** the force per unit area acting on the substance
- B** the increase in length per unit length of the substance
- C** the mass per unit volume of the substance
- D** the work done per unit time by the substance

9702/01/O/N/06

- 20 The table summarises some properties of evaporation.

9702/01/O/N/06

Which row of the table is correct?

	involves a change in state from liquid to vapour	occurs at a fixed temperature	involves a reduction in the average kinetic energy of the remaining atoms
<b>A</b>	true	true	true
<b>B</b>	true	false	true
<b>C</b>	true	false	false
<b>D</b>	false	true	false

- 15 The density of mercury is  $13.6 \times 10^3 \text{ kg m}^{-3}$ .

The pressure difference between the bottom and the top of a column of mercury is 100 kPa.

What is the height of the column?

9702/01/M/J/07

- A** 0.75 m      **B** 1.3 m      **C** 7.4 m      **D** 72 m

- 21 A bore hole of depth 2000 m contains both oil and water as shown. The pressure at the bottom is 17.5 MPa. The density of the oil is  $830 \text{ kg m}^{-3}$  and the density of the water is  $1000 \text{ kg m}^{-3}$ .

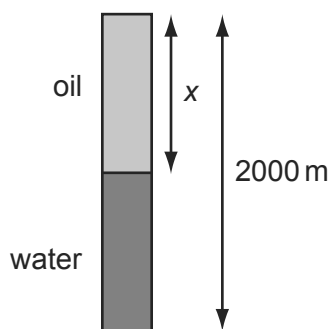

9702/01/O/N/06

What is the depth  $x$  of the oil?

- A 907 m      B 1000 m      C 1090 m      D 1270 m

- 16 Which group of statements applies only to the liquid state?

9702/01/M/J/07

**A**  
atoms separated by many atomic diameters  
positions of atoms can change  
atoms vibrate

**B**  
atoms separated by many atomic diameters  
atoms are in fixed positions  
atoms are in continuous, random motion

**C**  
atoms can touch each other  
positions of atoms can change  
some random motion of atoms

**D**  
atoms can touch each other  
atoms are in fixed positions  
some random motion of atoms

- 17 Two solid substances P and Q have atoms of mass  $M_P$  and  $M_Q$  respectively. There are  $n_P$  and  $n_Q$  atoms per unit volume respectively.

It is found by experiment that the density of P is greater than that of Q.

9702/01/O/N/07

Which deduction from this experiment must be correct?

- A  $M_P > M_Q$   
B  $n_P > n_Q$   
C  $M_P n_P > M_Q n_Q$   
D  $\frac{M_P}{n_P} > \frac{M_Q}{n_Q}$

- 18 A submarine carries a pressure meter so that the crew can work out how far they are below the surface of the sea. At the surface, the meter indicates a pressure of 100 kPa. The density of seawater is  $1030 \text{ kg m}^{-3}$ .

What is the depth below the surface when the meter reads 450 kPa?

9702/01/O/N/07

- A 34.6 m      B 44.5 m      C 340 m      D 437 m

- 20 Why does an ideal gas exert pressure on its container?

- A The molecules of the gas collide continually with each other.  
 B The molecules of the gas collide continually with the walls of the container.  
 C The molecules of the gas collide inelastically with the walls of the container.  
 D The weight of the molecules exerts a force on the walls of the container.

9702/01/M/J/08

- 21 The formula for hydrostatic pressure is  $p = \rho gh$ .

Which equation, or principle of physics, is used in the derivation of this formula?

9702/01/M/J/08

- A density = mass  $\div$  volume  
 B potential energy =  $mgh$   
 C atmospheric pressure decreases with height  
 D density increases with depth

- 16 Which row best describes how the molecules move in solids, in liquids and in gases?

9702/01/M/J/09

	solids	liquids	gases
A	fixed in position	only vibrate	move about freely
B	slowly in all directions	quickly in all directions	very quickly in all directions
C	vibrate about mean position	vibrate and move about	move about freely
D	vibrate in one direction only	vibrate in two directions	vibrate in all three directions

- 17 Water can exist in three states: solid, liquid or vapour. Transitions between these states can involve melting, freezing, evaporation or boiling.

Under conditions of constant pressure, which transition can occur over a range of temperatures rather than at one fixed temperature?

9702/01/M/J/09

- A boiling  
 B evaporation  
 C freezing  
 D melting

- 18 The diagram shows a flask connected to a U-tube containing liquid. The flask contains air at atmospheric pressure.

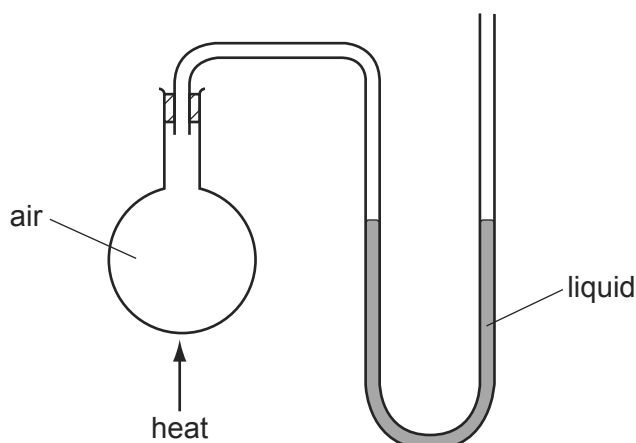

The flask is now gently heated and the liquid level in the right-hand side of the U-tube rises through a distance  $h$ . The density of the liquid is  $\rho$ .

What is the increase in pressure of the heated air in the flask?

9702/01/M/J/09

- A  $h\rho$       B  $\frac{1}{2}h\rho g$       C  $h\rho g$       D  $2h\rho g$

- 17 The diagram shows an ice cube floating in water.

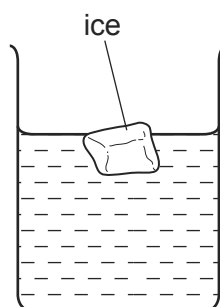

Both the ice cube and the water are at  $0^\circ\text{C}$ .

9702/11/O/N/09

Which statement correctly compares the molecular properties of the ice and those of the water?

- A The mean inter-molecular potential energies are the same for both the ice molecules and the water molecules.
- B The mean inter-molecular separations are the same for both the ice and the water.
- C The mean kinetic energies are the same for both the ice molecules and the water molecules.
- D The mean total energies are the same for both the ice molecules and the water molecules.
- 17 Atmospheric pressure at sea level has a value of 100 kPa.  
The density of sea water is  $1020\text{ kg m}^{-3}$ .

At what depth in the sea would the total pressure be 110 kPa?

9702/11/M/J/10

- A 1.0 m      B 9.8 m      C 10 m      D 11 m

18 In the kinetic model of gases, what is pressure equal to?

9702/11/O/N/09

- A the number of atoms hitting and rebounding from a surface of the gas container
- B the number of atoms hitting and rebounding from a unit area of the gas container surface
- C the force exerted by the atoms hitting and rebounding from a surface of the gas container
- D the force exerted by the atoms hitting and rebounding from a unit area of the gas container surface

19 A rectangular metal bar exerts a pressure of 15 200 Pa on the horizontal surface on which it rests.

If the height of the metal bar is 80 cm, what is the density of the metal?

9702/11/O/N/09

- A  $190 \text{ kg m}^{-3}$
- B  $1900 \text{ kg m}^{-3}$
- C  $19\,000 \text{ kg m}^{-3}$
- D  $190\,000 \text{ kg m}^{-3}$

14 An object, immersed in a liquid in a tank, experiences an upthrust.

What is the physical reason for this upthrust?

9702/11/M/J/10

- A The density of the body differs from that of the liquid.
- B The density of the liquid increases with depth.
- C The pressure in the liquid increases with depth.
- D The value of  $g$  in the liquid increases with depth.

18 When ice melts, it contracts.

Which row is correct for ice turning into water?

9702/11/M/J/10

	distance between atoms	density
A	decreases	decreases
B	decreases	increases
C	increases	decreases
D	increases	increases

18 Atmospheric pressure at sea level has a value of 100 kPa.  
The density of sea water is  $1020 \text{ kg m}^{-3}$ .

9702/12/M/J/10

At what depth in the sea would the total pressure be 110 kPa?

- A 1.0 m
- B 9.8 m
- C 10 m
- D 11 m



17 When ice melts, it contracts.

Which row is correct for ice turning into water?

9702/12/M/J/10

	distance between atoms	density
<b>A</b>	decreases	decreases
<b>B</b>	decreases	increases
<b>C</b>	increases	decreases
<b>D</b>	increases	increases

16 The diagram shows an ice cube floating in water.

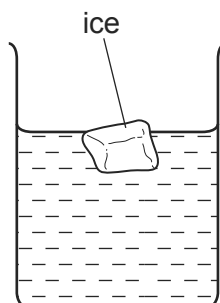

Both the ice cube and the water are at 0 °C.

9702/12/O/N/09

Which statement correctly compares the molecular properties of the ice and those of the water?

- A** The mean inter-molecular potential energies are the same for both the ice molecules and the water molecules.
- B** The mean inter-molecular separations are the same for both the ice and the water.
- C** The mean kinetic energies are the same for both the ice molecules and the water molecules.
- D** The mean total energies are the same for both the ice molecules and the water molecules.

17 In the kinetic model of gases, what is pressure equal to?

9702/12/O/N/09

- A** the number of atoms hitting and rebounding from a surface of the gas container
- B** the number of atoms hitting and rebounding from a unit area of the gas container surface
- C** the force exerted by the atoms hitting and rebounding from a surface of the gas container
- D** the force exerted by the atoms hitting and rebounding from a unit area of the gas container surface

18 A rectangular metal bar exerts a pressure of 15 200 Pa on the horizontal surface on which it rests.

If the height of the metal bar is 80 cm, what is the density of the metal?

9702/12/O/N/09

- A  $190 \text{ kg m}^{-3}$
- B  $1900 \text{ kg m}^{-3}$
- C  $19\,000 \text{ kg m}^{-3}$
- D  $190\,000 \text{ kg m}^{-3}$

19 The Mariana Trench in the Pacific Ocean has a depth of about 10 km.

9702/11/O/N/10

Assuming that sea water is incompressible and has a density of about  $1020 \text{ kg m}^{-3}$ , what would be the approximate pressure at that depth?

- A  $10^5 \text{ Pa}$       B  $10^6 \text{ Pa}$       C  $10^7 \text{ Pa}$       D  $10^8 \text{ Pa}$

20 A student writes some statements about solids, liquids and gases.

- 1 Solids are rigid because the molecules in a solid vibrate.
- 2 Liquids flow because the molecules in a liquid are closer than in a gas.
- 3 Gases are less dense than liquids because the molecules in a gas move randomly.

Which statements are correct?

9702/11/O/N/10

- A 1 only
- B 1 and 3 only
- C 2 and 3 only
- D none of the above

18 Below are four short paragraphs describing the molecules in a beaker of water at  $50^\circ\text{C}$ .

Which paragraph correctly describes the molecules?

9702/12/O/N/10

- A The molecules all travel at the same speed. This speed is not large enough for any of the molecules to leave the surface of the water. There are attractive forces between the molecules.
- B The molecules have a range of speeds. Some molecules travel sufficiently fast to leave the surface of the water. There are no forces between the molecules.
- C The molecules have a range of speeds. Some molecules travel sufficiently fast to leave the surface of the water. There are attractive forces between the molecules.
- D The molecules have a range of speeds. The fastest molecules are unable to leave the surface of the water. There are attractive forces between the molecules.

19 Which group of materials contains two polymers?

9702/12/O/N/10

- A copper sand polystyrene
- B glass wood aluminium
- C nylon sugar rubber
- D stone diamond steel

20 The pressure at sea level is approximately 100 000 Pa. The density of sea water is  $1030 \text{ kg m}^{-3}$ .

What is the approximate pressure 80 m below the surface of the sea?

9702/12/O/N/10

- A 100 000 Pa
- B 180 000 Pa
- C 800 000 Pa
- D 900 000 Pa

20 The Mariana Trench in the Pacific Ocean has a depth of about 10 km.

9702/13/O/N/10

Assuming that sea water is incompressible and has a density of about  $1020 \text{ kg m}^{-3}$ , what would be the approximate pressure at that depth?

- A  $10^5 \text{ Pa}$
- B  $10^6 \text{ Pa}$
- C  $10^7 \text{ Pa}$
- D  $10^8 \text{ Pa}$

22 A student writes some statements about solids, liquids and gases.

9702/13/O/N/10

- 1 Solids are rigid because the molecules in a solid vibrate.
- 2 Liquids flow because the molecules in a liquid are closer than in a gas.
- 3 Gases are less dense than liquids because the molecules in a gas move randomly.

Which statements are correct?

- A 1 only
- B 1 and 3 only
- C 2 and 3 only
- D none of the above

18 Which process does **not** require energy to be supplied?

9702/11/M/J/11

- A boiling
- B evaporation
- C freezing
- D melting

19  $1.5 \text{ m}^3$  of water is mixed with  $0.50 \text{ m}^3$  of alcohol. The density of water is  $1000 \text{ kg m}^{-3}$  and the density of alcohol is  $800 \text{ kg m}^{-3}$ .

What is the density of the mixture with volume  $2.0 \text{ m}^3$ ?

9702/11/M/J/11

- A  $850 \text{ kg m}^{-3}$
- B  $900 \text{ kg m}^{-3}$
- C  $940 \text{ kg m}^{-3}$
- D  $950 \text{ kg m}^{-3}$

- 20 The diagram shows two vessels, P and Q, both with sides inclined at  $45^\circ$ .

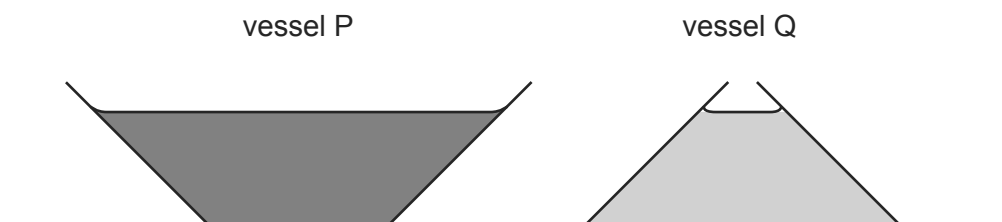

Vessel P tapers outwards and vessel Q tapers inwards, as shown.

9702/12/M/J/11

Both vessels contain a liquid. The depth of the liquid in the vessels is the same. The liquid in vessel P is twice as dense as the liquid in vessel Q.

What is the ratio  $\frac{\text{pressure due to the liquid on the base of P}}{\text{pressure due to the liquid on the base of Q}}$ ?

- A  $\frac{2}{1}$       B  $\frac{\sqrt{2}}{1}$       C  $\frac{1}{\sqrt{2}}$       D  $\frac{1}{2}$

- 21 Two solid substances P and Q have atoms of mass  $M_P$  and  $M_Q$  respectively. They have  $n_P$  and  $n_Q$  atoms per unit volume.

The density of P is greater than the density of Q.

9702/12/M/J/11

What **must** be correct?

- A  $M_P > M_Q$   
 B  $n_P > n_Q$   
 C  $M_P n_P > M_Q n_Q$   
 D  $\frac{M_P}{n_P} > \frac{M_Q}{n_Q}$

- 22 The table summarises some descriptions of evaporation.

Which row of the table is correct?

9702/12/M/J/11

	involves a change in state from liquid to vapour	occurs at a fixed temperature	involves a reduction in the average kinetic energy of the remaining atoms
A	true	true	true
B	true	false	true
C	true	false	false
D	false	true	false

- 18 Which process does **not** require energy to be supplied? 9702/13/M/J/11
- A boiling
  - B evaporation
  - C freezing
  - D melting
- 19  $1.5 \text{ m}^3$  of water is mixed with  $0.50 \text{ m}^3$  of alcohol. The density of water is  $1000 \text{ kg m}^{-3}$  and the density of alcohol is  $800 \text{ kg m}^{-3}$ .
- What is the density of the mixture with volume  $2.0 \text{ m}^3$ ? 9702/13/M/J/11
- A  $850 \text{ kg m}^{-3}$     B  $900 \text{ kg m}^{-3}$     C  $940 \text{ kg m}^{-3}$     D  $950 \text{ kg m}^{-3}$
- 21 Why does the pressure increase when a sealed container of gas is heated? 9702/11/O/N/11
- A The gas molecules collide more often with each other.
  - B The gas molecules expand when they are heated.
  - C The gas molecules travel faster and hit the walls of the container more often.
  - D There are more gas molecules present to collide with the walls of the container.
- 22 Pollen grains are suspended in a liquid and are illuminated strongly. When observed under a microscope they are seen to be in continuous random motion.
- What is the reason for this? 9702/11/O/N/11
- A convection currents in the liquid
  - B evaporation of the liquid
  - C molecules of the liquid colliding with the pollen grains
  - D pollen grains colliding with each other
- 19 In an experiment to demonstrate Brownian motion, smoke particles in a container are illuminated by a strong light source and observed through a microscope.
- The particles are seen as small specks of light that are in motion. 9702/12/O/N/11
- What causes the Brownian motion?
- A collisions between the smoke particles and air molecules
  - B collisions between the smoke particles and the walls of the container
  - C convection currents within the air as it is warmed by the light source
  - D kinetic energy gained by the smoke particles on absorption of light

- 20 A horizontal plate of area  $0.036 \text{ m}^2$  is beneath the surface of a liquid of density  $930 \text{ kg m}^{-3}$ . The force on the plate due to the pressure of the liquid is 290 N.

What is the depth of the plate beneath the surface of the liquid?

9702/12/O/N/11

- A 0.88 m      B 1.13 m      C 8.7 m      D 9.1 m

- 23 Pollen grains are suspended in a liquid and are illuminated strongly. When observed under a microscope they are seen to be in continuous random motion.

What is the reason for this?

9702/13/O/N/11

- A convection currents in the liquid  
B evaporation of the liquid  
C molecules of the liquid colliding with the pollen grains  
D pollen grains colliding with each other

- 24 Why does the pressure increase when a sealed container of gas is heated?

- A The gas molecules collide more often with each other.  
B The gas molecules expand when they are heated.  
C The gas molecules travel faster and hit the walls of the container more often.  
D There are more gas molecules present to collide with the walls of the container.

9702/13/O/N/11

- 21 At room temperature, the density of liquid mercury is five times greater than the density of solid aluminium.

9702/11/M/J/12

What is the reason for this?

- A Aluminium atoms are spaced widely apart.  
B Aluminium atoms move more freely than mercury atoms.  
C Atoms in a liquid take up less space than atoms in a solid.  
D Mercury atoms have greater mass than aluminium atoms.

- 22 When white sugar granules are heated, they melt. When the melt is cooled quickly, a brittle solid form of toffee is produced.

9702/11/M/J/12

How does the structure of the sugar change?

- A amorphous to polymeric  
B crystalline to amorphous  
C crystalline to polymeric  
D polymeric to amorphous

- 20 Each box shows identical molecules of a gas represented by circles with arrows to show the direction of travel and the speed of the molecule. A longer arrow represents a higher speed.

9702/11/M/J/12

Which box contains a gas of the highest density and the lowest temperature?

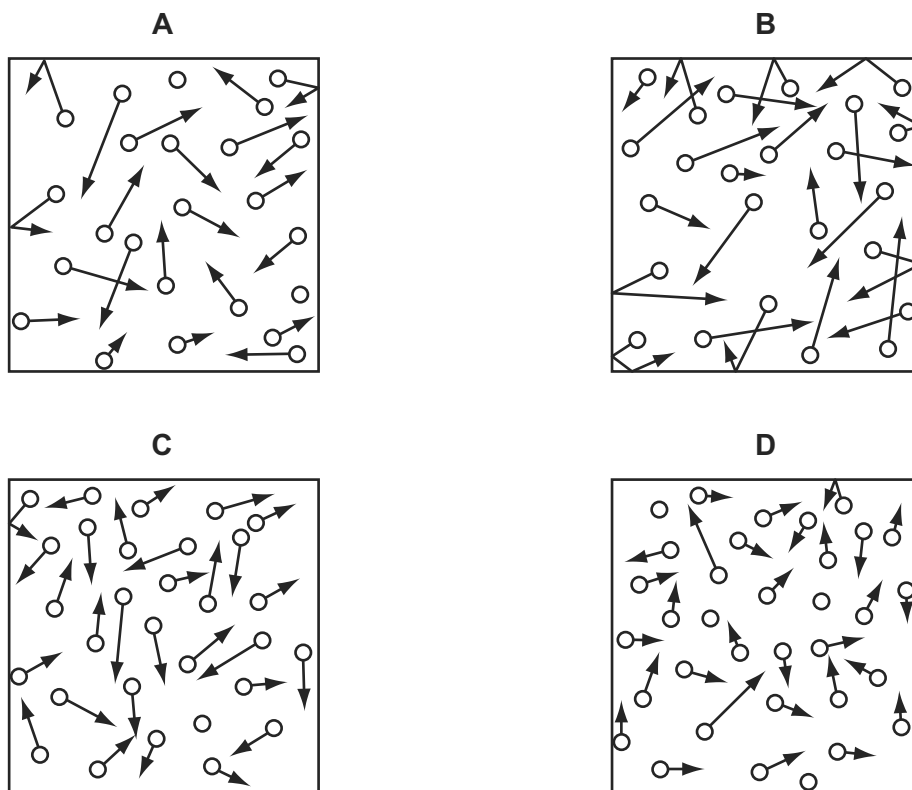

- 22 The diagram shows the arrangement of atoms in a particular crystal.

9702/12/M/J/12

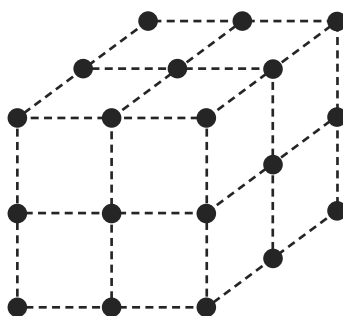

Each atom is at the corner of a cube.

The mass of each atom is  $3.5 \times 10^{-25}$  kg. The density of the crystal is  $9.2 \times 10^3$  kg m<sup>-3</sup>.

What is the shortest distance between the centres of two adjacent atoms?

- A  $3.8 \times 10^{-29}$  m  
 B  $6.2 \times 10^{-15}$  m  
 C  $3.4 \times 10^{-10}$  m  
 D  $3.0 \times 10^{-9}$  m

- 21 In an experiment to demonstrate Brownian motion, a transparent container is filled with smoke particles suspended in air. 9702/12/M/J/12

What can be seen when the contents of the container are strongly illuminated and viewed through a microscope?

- A air molecules that are colliding with smoke particles  
 B air molecules that are moving in straight lines  
 C smoke particles that are moving in random zigzag paths  
 D smoke particles that are moving in straight lines
- 24 At room temperature, the density of liquid mercury is five times greater than the density of solid aluminium. 9702/13/M/J/12

What is the reason for this?

- A Aluminium atoms are spaced widely apart.  
 B Aluminium atoms move more freely than mercury atoms.  
 C Atoms in a liquid take up less space than atoms in a solid.  
 D Mercury atoms have greater mass than aluminium atoms.
- 23 A pipe is closed at one end and contains gas, trapped by a column of water. 9702/12/M/J/12

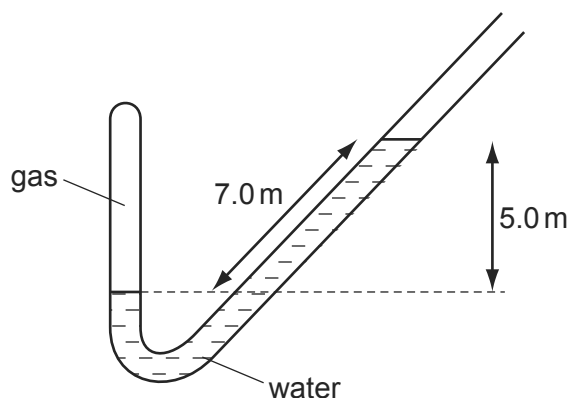

The atmospheric pressure is  $1.0 \times 10^5$  Pa. The density of water is  $1000 \text{ kg m}^{-3}$ .

What is the pressure of the gas? (Use  $g = 10 \text{ m s}^{-2}$ .)

- A  $0.3 \times 10^5$  Pa  
 B  $0.5 \times 10^5$  Pa  
 C  $1.5 \times 10^5$  Pa  
 D  $1.7 \times 10^5$  Pa



- 23** When white sugar granules are heated, they melt. When the melt is cooled quickly, a brittle solid form of toffee is produced.

9702/13/M/J/12

How does the structure of the sugar change?

- A** amorphous to polymeric  
**B** crystalline to amorphous  
**C** crystalline to polymeric  
**D** polymeric to amorphous
- 25** Each box shows identical molecules of a gas represented by circles with arrows to show the direction of travel and the speed of the molecule. A longer arrow represents a higher speed.

Which box contains a gas of the highest density and the lowest temperature?

9702/13/M/J/12

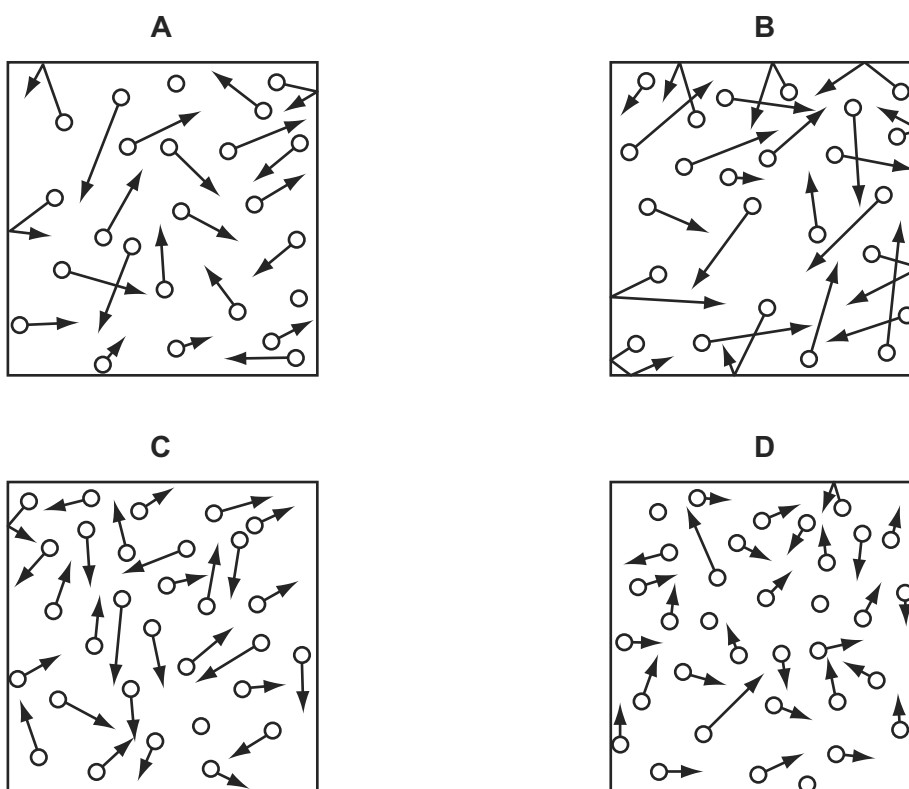

- 25** What leads to the conclusion that the movement of molecules is random?

9702/12/O/N/12

- A** evaporation of water at room temperature  
**B** conduction of electricity in water  
**C** convection currents in air  
**D** motion of dust particles in air

- 23 Which row correctly describes the spacing and motion of the molecules in water and in ice when both are at a temperature of 0 °C?

9702/12/O/N/12

	spacing	motion
<b>A</b>	molecules in ice are further apart than molecules in water	molecules in both ice and water have the same average speed
<b>B</b>	molecules in ice are further apart than molecules in water	molecules in ice travel more slowly than those in water
<b>C</b>	molecules in ice are closer than molecules in water	molecules in ice travel more slowly than those in water
<b>D</b>	molecules in ice are closer than molecules in water	molecules in both ice and water have the same average speed

- 24 Which row gives the correct description for the arrangement of atoms in the four types of material?

9702/12/O/N/12

	atoms have no long-range order	atoms form giant chain-like molecules	atoms have an ordered arrangement in regions, but these ordered regions are at angles to one another	atoms are arranged in an ordered way throughout
<b>A</b>	crystalline	amorphous	polymeric	polycrystalline
<b>B</b>	polycrystalline	crystalline	amorphous	polymeric
<b>C</b>	polymeric	polycrystalline	crystalline	amorphous
<b>D</b>	amorphous	polymeric	polycrystalline	crystalline

- 22 Which row correctly describes the spacing, ordering and motion of the molecules in water and in ice when both are at a temperature of 0 °C?

9702/11/O/N/12

	spacing	ordering	motion
<b>A</b>	molecules in ice are closer together than molecules in water	a regular pattern of molecules in both ice and water	molecules in both ice and water have the same average speed
<b>B</b>	molecules in ice are closer together than molecules in water	a regular pattern of molecules in ice but not in water	molecules in ice travel more slowly than those in water
<b>C</b>	molecules in ice are further apart than molecules in water	a regular pattern of molecules in both ice and water	molecules in ice travel more slowly than those in water
<b>D</b>	molecules in ice are further apart than molecules in water	a regular pattern of molecules in ice but not in water	molecules in both ice and water have the same average speed

- 26 The diagram shows the force-extension graphs for two materials, of the same dimensions, loaded to fracture.

9702/12/O/N/12

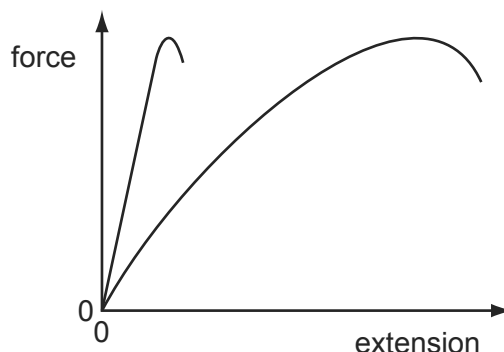

What describes the behaviour of the materials?

- A Both materials are brittle.  
 B Both materials obey Hooke's law.  
 C Both materials are plastic.  
 D Both materials have the same ultimate tensile stress.
- 22 Which row correctly describes the ordering and motion of the molecules in water and in ice when both are at a temperature of  $0^{\circ}\text{C}$ ?

9702/13/O/N/12

	ordering	motion
<b>A</b>	a regular pattern of molecules in ice but not in water	molecules in both ice and water have the same average speed
<b>B</b>	a regular pattern of molecules in ice but not in water	molecules in ice travel more slowly than those in water
<b>C</b>	a regular pattern of molecules in both ice and water	molecules in ice travel more slowly than those in water
<b>D</b>	a regular pattern of molecules in both ice and water	molecules in both ice and water have the same average speed

- 23 The diagram shows a rectangular block of mass  $8.2\text{ kg}$  immersed in sea water of density  $1.10 \times 10^3\text{ kg m}^{-3}$ .

9702/13/O/N/12

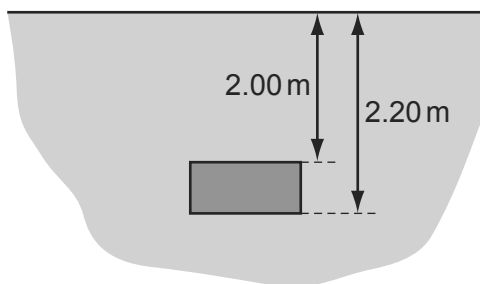

What is the difference in pressure between the top and bottom surfaces of the block?

- A  $2.2 \times 10^2\text{ Pa}$   
 B  $2.2 \times 10^3\text{ Pa}$   
 C  $1.8 \times 10^4\text{ Pa}$   
 D  $2.3 \times 10^4\text{ Pa}$
- 20 Which row correctly states the characteristics of the process of evaporation?

9702/11/M/J/13

	requires heat energy	occurs only at a particular temperature	can cause a change of temperature
A	✓	✓	✗
B	✓	✗	✓
C	✗	✓	✗
D	✗	✗	✓

- 21 A bore-hole of depth  $2000\text{ m}$  contains both oil and water as shown. The pressure due to the liquids at the bottom of the bore-hole is  $17.5\text{ MPa}$ . The density of the oil is  $830\text{ kg m}^{-3}$  and the density of the water is  $1000\text{ kg m}^{-3}$ .

9702/11/M/J/13

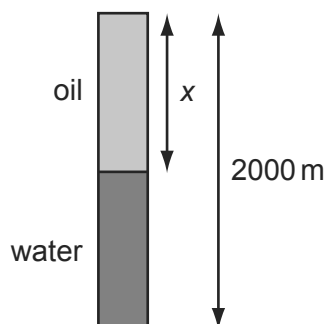

What is the depth  $x$  of the oil?

- A  $907\text{ m}$       B  $1000\text{ m}$       C  $1090\text{ m}$       D  $1270\text{ m}$

- 19 The diagram shows an ice cube floating in water.

9702/12/M/J/13

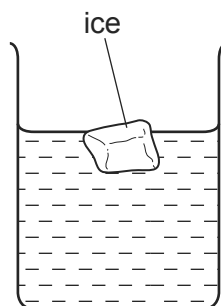

Both the ice cube and the water are at  $0^{\circ}\text{C}$ .

Which statement correctly compares the molecular properties of the ice and those of the water?

- A** The mean inter-molecular potential energies are the same for both the ice molecules and the water molecules.
- B** The mean inter-molecular separations are the same for both the ice and the water.
- C** The mean kinetic energies are the same for both the ice molecules and the water molecules.
- D** The mean total energies are the same for both the ice molecules and the water molecules.
- 20 Two bulbs X and Y containing air at different pressures are connected by a tube P which contains two mercury threads.

9702/12/M/J/13

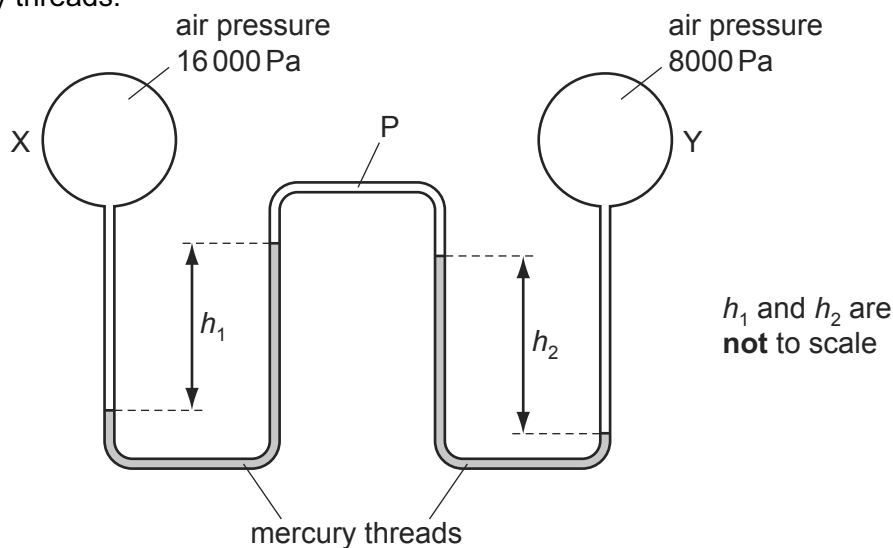

The density of mercury is  $13\,600\text{ kg m}^{-3}$ .

Which pair of values of  $h_1$  and  $h_2$  is possible?

	$h_1/\text{cm}$	$h_2/\text{cm}$
<b>A</b>	4.0	2.0
<b>B</b>	6.0	6.0
<b>C</b>	12.0	18.0
<b>D</b>	18.0	12.0

- 17 Ice at a temperature of  $0^{\circ}\text{C}$  is a rare example of a solid that floats on its liquid form, in this case water, when they are both at the same temperature.

9702/13/M/J/13

What is the explanation for this?

- A The average speed of the molecules in the ice is greater than the average speed of the molecules in the water.
  - B The average speed of the molecules in the water is greater than the average speed of the molecules in the ice.
  - C The mean separation of the molecules in the ice is greater than the mean separation of the molecules in the water.
  - D The mean separation of the molecules in the water is greater than the mean separation of the molecules in the ice.
- 18 The formula for hydrostatic pressure is  $p = \rho gh$ .

9702/13/M/J/13

Which equation, or principle of physics, is used in the derivation of this formula?

- A  $\text{density} = \frac{\text{mass}}{\text{volume}}$
- B  $\text{potential energy} = mgh$
- C atmospheric pressure decreases with height
- D density increases with depth

- 20 Below are four short paragraphs describing the molecules in a beaker of water at  $50^{\circ}\text{C}$ .

9702/11/O/N/13

Which paragraph correctly describes the molecules?

- A The molecules all travel at the same speed. This speed is not large enough for any of the molecules to leave the surface of the water. There are attractive forces between the molecules.
  - B The molecules have a range of speeds. Some molecules travel sufficiently fast to leave the surface of the water. There are no forces between the molecules.
  - C The molecules have a range of speeds. The fastest molecules are unable to leave the surface of the water. There are attractive forces between the molecules.
  - D The molecules have a range of speeds. Some molecules travel sufficiently fast to leave the surface of the water. There are attractive forces between the molecules.
- 21 Which two substances are normally both crystalline?
- A copper and diamond
  - B copper and glass
  - C diamond and glass
  - D diamond and rubber

9702/11/O/N/13

- 22 Water in a bath varies in depth from 20.0 cm at the shallow end to 30.0 cm at the end with the plug.

9702/11/O/N/13

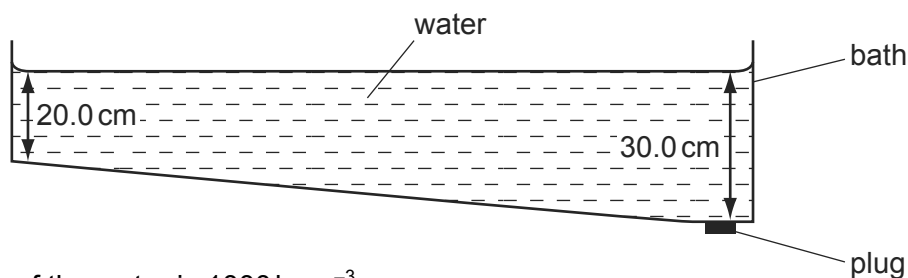

The density of the water is  $1000 \text{ kg m}^{-3}$ .

What is the pressure of the water acting on the plug?

- A 1960 Pa      B 2450 Pa      C 2940 Pa      D 4900 Pa
- 20 Gold has a density of  $19.3 \text{ g cm}^{-3}$ .

9702/13/O/N/13

The volume occupied by a single atom of gold may be considered to be a cube with sides of length  $2.6 \times 10^{-8} \text{ cm}$ .

What is the mass of a gold atom?

- A  $3.4 \times 10^{-25} \text{ g}$   
 B  $3.4 \times 10^{-22} \text{ g}$   
 C  $1.3 \times 10^{-17} \text{ g}$   
 D  $1.3 \times 10^{-14} \text{ g}$
- 21 In an experiment to demonstrate Brownian motion, a transparent container is filled with smoke particles suspended in air.

9702/13/O/N/13

What can be seen when the contents of the container are strongly illuminated and viewed through a microscope?

- A molecules in random motion  
 B molecules vibrating regularly  
 C smoke particles in random motion  
 D smoke particles vibrating regularly
- 17 Which statement about boiling and evaporation is correct?
- A Boiling can only occur at the surface of a liquid.  
 B Evaporation can only occur at a fixed temperature.  
 C Only boiling involves a change of phase.  
 D When some of a liquid evaporates, the rest of the liquid becomes cooler.

9702/11/M/J/14

- 18 There is one temperature, about  $0.01^{\circ}\text{C}$ , at which water, water vapour and ice can co-exist in equilibrium.

9702/11/M/J/14

Which statement about the properties of the molecules at this temperature is correct?

- A Ice molecules are closer to one another than water molecules.
- B The mean kinetic energy of water molecules is greater than the mean kinetic energy of ice molecules.
- C Water vapour molecules are less massive than water molecules.
- D Water vapour molecules have the same mean speed as both ice and water molecules.
- 19 A crystalline solid is heated at a constant rate and the change of temperature with time is shown in the graph below.

9702/11/M/J/14

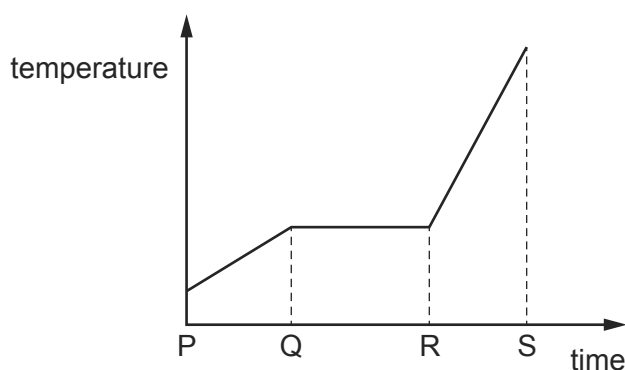

Which statement about the particles in the material is correct?

- A In the time from P to Q, the particles are arranged randomly.
- B In the time from Q to R, some particles are arranged regularly and some particles are arranged randomly.
- C In the time from R to S, the particles are widely spaced.
- D The arrangement of the particles is the same in the time from P to S.
- 19 When the water in a pond freezes, it changes from a liquid to a solid. When this occurs, it changes volume and exchanges energy with the surroundings.

9702/13/M/J/14

Which row is correct?

	change of volume	energy exchange
A	contracts	gives out energy to the surroundings
B	contracts	takes in energy from the surroundings
C	expands	gives out energy to the surroundings
D	expands	takes in energy from the surroundings



- 17 If the Universe was such that the speed of the molecules in a substance increased with temperature but at any particular temperature the speed of all the molecules in a substance was the same, which process would **not** occur?

9702/12/M/J/14

- A boiling
- B condensation
- C evaporation
- D melting

- 20 Which process does **not** require energy to be supplied?

9702/13/M/J/14

- A boiling
- B evaporation
- C freezing
- D melting

- 18 Liquid Q has twice the density of liquid R.

9702/12/M/J/14

At depth  $x$  in liquid R, the pressure due to the liquid is 4 kPa.

At what depth in liquid Q is the pressure due to the liquid 7 kPa?

- A  $\frac{2x}{7}$       B  $\frac{7x}{8}$       C  $\frac{8x}{7}$       D  $\frac{7x}{2}$

- 21 The graph shows the distribution of speeds for the molecules of a gas at a particular temperature.

9702/13/M/J/14

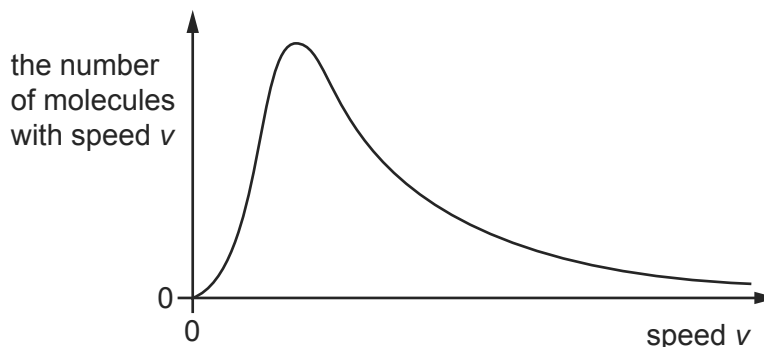

Which statement is correct?

- A All the molecules have the same kinetic energy.
- B The commonest value of speed is also the average speed.
- C The graph shows that the molecules of a gas are widely spaced apart.
- D The peak value of the graph would move to the right if the temperature is increased.

18 Which statement about molecules in a gas is correct?

9702/11/O/N/14

- A In Brownian motion experiments, the molecules can be seen moving randomly in all directions.
- B The pressure exerted by a gas is caused by molecules bouncing against each other and changing kinetic energy.
- C The pressure exerted by a gas is caused by molecules rebounding from the walls of a container and changing momentum.
- D When the average speed of the molecules in a closed container increases, the density must also increase.

19 The diagram shows the atoms of a substance with the atoms at the corners of a cube. The average separation of the atoms at a particular temperature is 15 nm.

9702/11/O/N/14

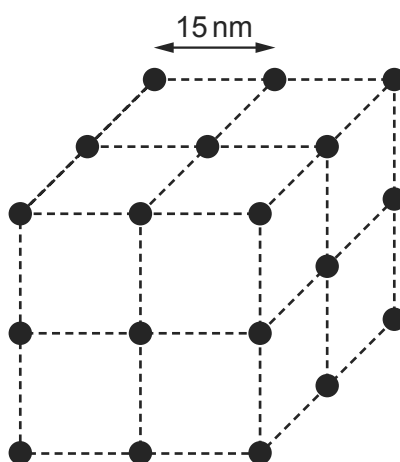

When the temperature changes so that the average separation becomes 17 nm, by which factor will the density of the substance change?

- A 0.61                      B 0.69                      C 0.78                      D 0.88

17 What is the correct name for a material containing long-chain molecules that are tangled and coiled?

9702/11/O/N/14

- A amorphous metal
- B amorphous polymer
- C crystalline metal
- D crystalline polymer

20 Atmospheric pressure at sea level has a value of 100 kPa. The density of sea water is  $1020 \text{ kg m}^{-3}$ .

9702/13/O/N/14

At which depth in the sea would the total pressure be 110 kPa?

- A 1.0 m                      B 9.8 m                      C 10 m                      D 11 m

- 21 A student is studying Brownian motion.

Using a microscope, she observes particles of smoke in a glass container, illuminated by a strong light. The particles of smoke have a zig-zag path, constantly changing speed and direction.

What happens to the smoke particles if the air in the container is heated?

- A The smoke particles become easier to see.  
 B The smoke particles change direction more frequently.  
 C The smoke particles increase in volume.  
 D The smoke particles move further apart.
- 22 The diagram shows two liquids, labelled P and Q, which do **not** mix. The liquids are in equilibrium in an open U-tube.

9702/13/O/N/14

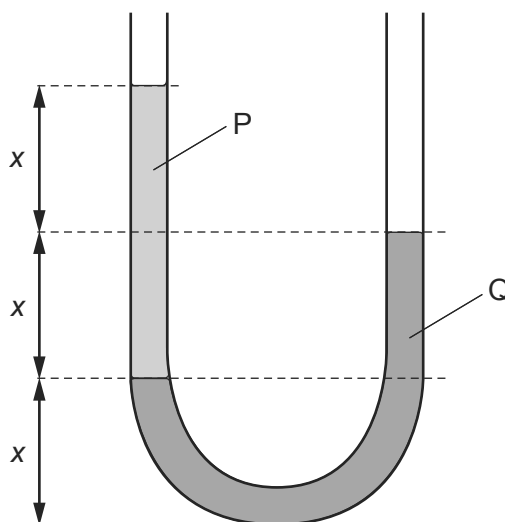

What is the ratio  $\frac{\text{density of P}}{\text{density of Q}}$ ?

- A  $\frac{1}{2}$       B  $\frac{2}{3}$       C  $\frac{3}{2}$       D 2
- 20 When ice melts, it contracts.

9702/13/M/J/15

Which row is correct for ice turning into water?

	distance between molecules	density
A	decreases	decreases
B	decreases	increases
C	increases	decreases
D	increases	increases

- 21 A W-shaped tube contains two amounts of mercury, each open to the atmosphere. Air at pressure  $P$  is trapped in between them. The diagram shows two vertical distances  $x$  and  $y$ .

9702/13/M/J/15

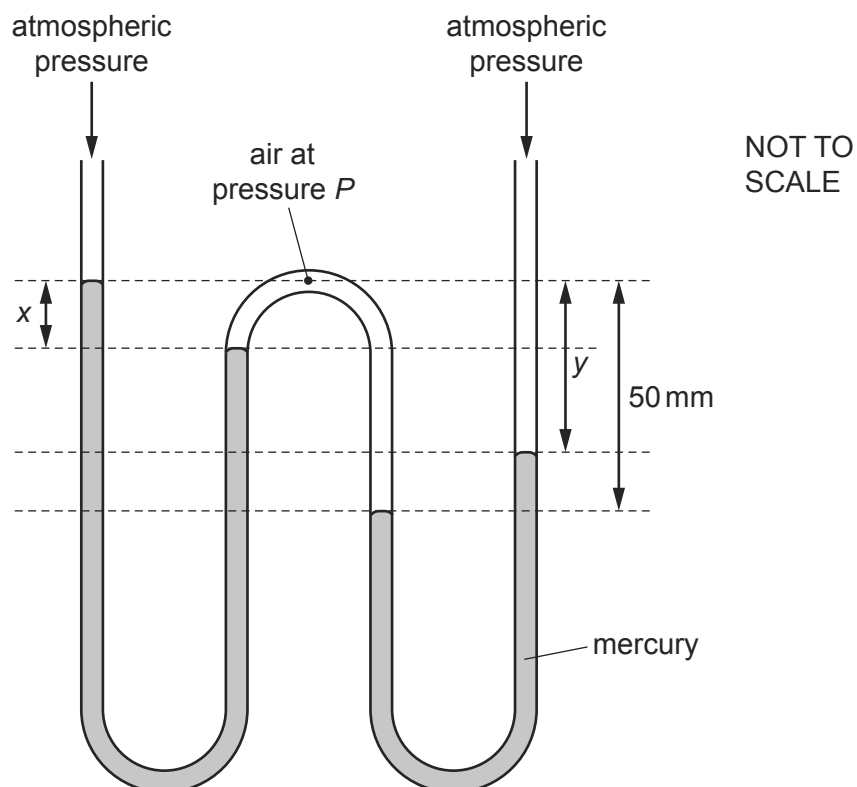

Atmospheric pressure is equal to the pressure that would be exerted by a column of mercury of height 760 mm. The pressure  $P$  is expressed in this way.

Which values of  $x$ ,  $y$  and  $P$  are possible?

	$x/\text{mm}$	$y/\text{mm}$	$P/\text{mm of mercury}$
<b>A</b>	20	20	780
<b>B</b>	20	30	780
<b>C</b>	30	20	810
<b>D</b>	30	30	790

- 20 The maximum pressure that granite rock can withstand is  $2.0 \times 10^8 \text{ N m}^{-2}$ . Above this pressure, the rock begins to flow like a liquid. The density of granite is  $2.7 \times 10^3 \text{ kg m}^{-3}$ .

9702/12/M/J/15

What would be the height of a pure granite mountain whose base is just beginning to flow?

- A**  $3.8 \times 10^3 \text{ m}$     **B**  $7.6 \times 10^3 \text{ m}$     **C**  $3.7 \times 10^4 \text{ m}$     **D**  $7.4 \times 10^4 \text{ m}$

- 19 Which row correctly describes the ordering and motion of the molecules in liquid water and in ice when both are at a temperature of  $0\text{ }^{\circ}\text{C}$ ?

9702/12/M/J/15

	ordering	motion
<b>A</b>	a regular pattern of molecules in ice but not in water	molecules in both ice and water have the same average speed
<b>B</b>	a regular pattern of molecules in ice but not in water	molecules in ice travel more slowly than those in water
<b>C</b>	a regular pattern of molecules in both ice and water	molecules in ice travel more slowly than those in water
<b>D</b>	a regular pattern of molecules in both ice and water	molecules in both ice and water have the same average speed

- 21 The diagram shows the arrangement of atoms in a particular crystal.

9702/11/M/J/15

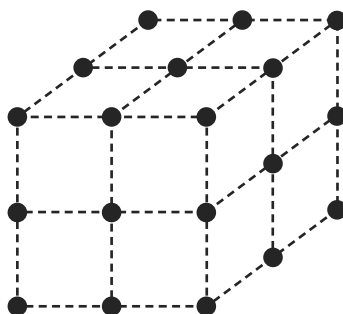

Each atom is at the corner of a cube.

The mass of each atom is  $3.5 \times 10^{-25}$  kg. The density of the crystal is  $9.2 \times 10^3$  kg m<sup>-3</sup>.

What is the shortest distance between the centres of two adjacent atoms?

- A**  $3.8 \times 10^{-29}$  m
- B**  $6.2 \times 10^{-15}$  m
- C**  $3.4 \times 10^{-10}$  m
- D**  $3.0 \times 10^{-9}$  m

20 Descriptions of three different types of material are listed.

- 1 a polycrystalline material made up of large numbers of small crystals
- 2 an amorphous material with little or no ordered arrangement of molecules
- 3 a polymeric material consisting of long chains of molecules

Which row correctly matches the descriptions to nylon, copper and glass?

	1	2	3
A	copper	glass	nylon
B	copper	nylon	glass
C	glass	nylon	copper
D	nylon	copper	glass

1 Which path shows a possible movement of an electron in the electric field shown?

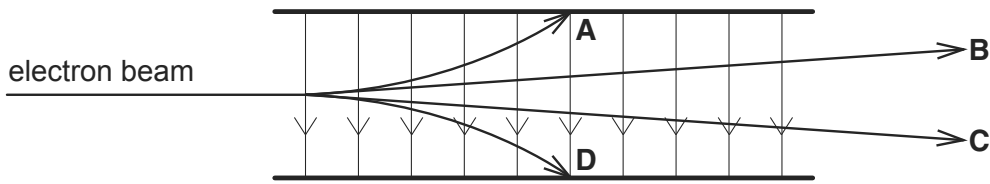

2 Two parallel conducting plates are connected to a battery, one plate to the positive terminal and the other plate to the negative. The plate separation is gradually increased, the plates remaining connected to the battery.

Which graph shows how the electric field  $E$  between the plates depends on the plate separation  $x$ ?

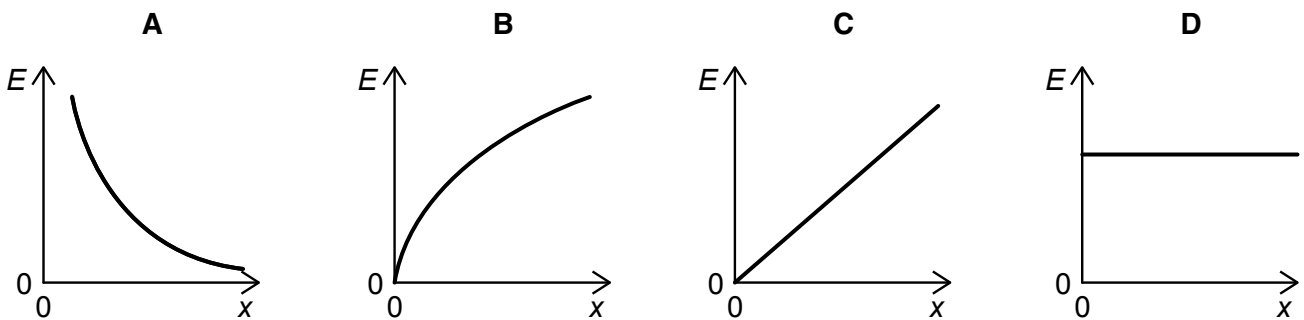

3 Which diagram shows the electric field pattern of an isolated negative point charge?

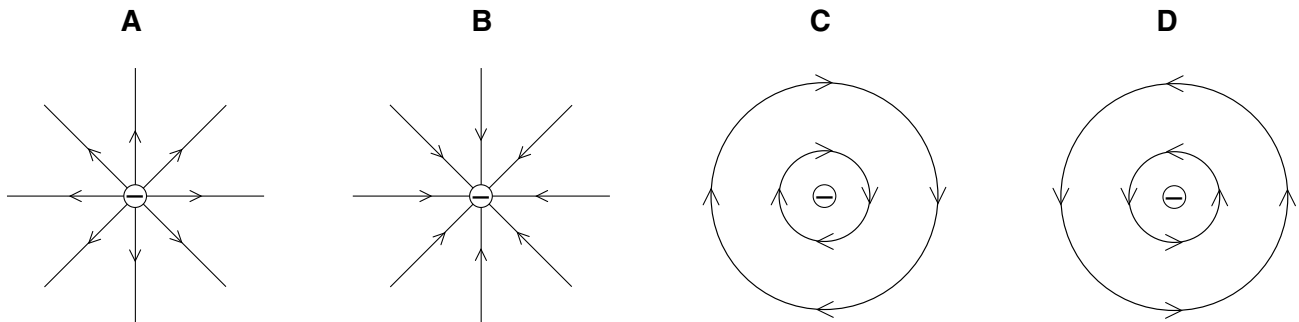

4 A positive charge and a negative charge of equal magnitude are placed a short distance apart.

Which diagram best represents the associated electric field?

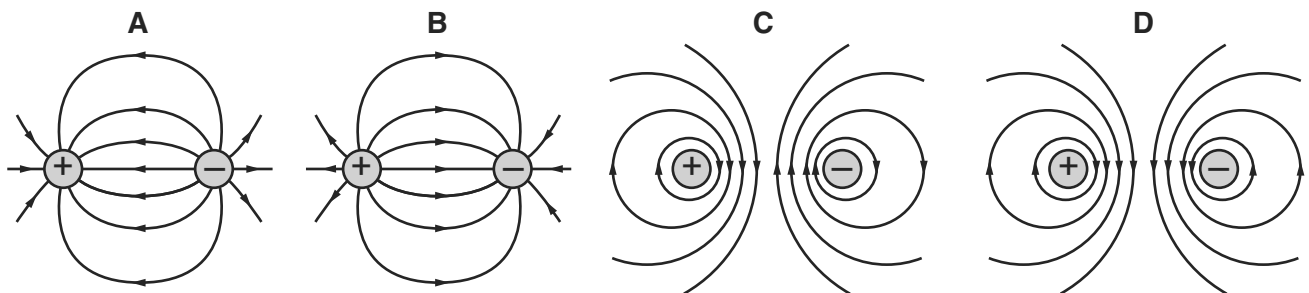

- 5 An electric field exists in the space between two charged metal plates.

9702/01/M/J/03/Q35

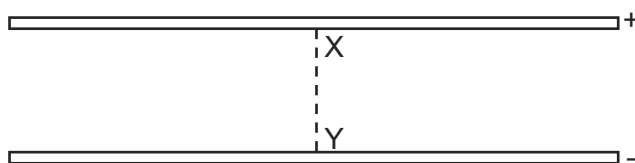

Which of the following graphs shows the variation of electric field strength  $E$  with distance  $d$  from  $X$  along the line  $XY$ ?

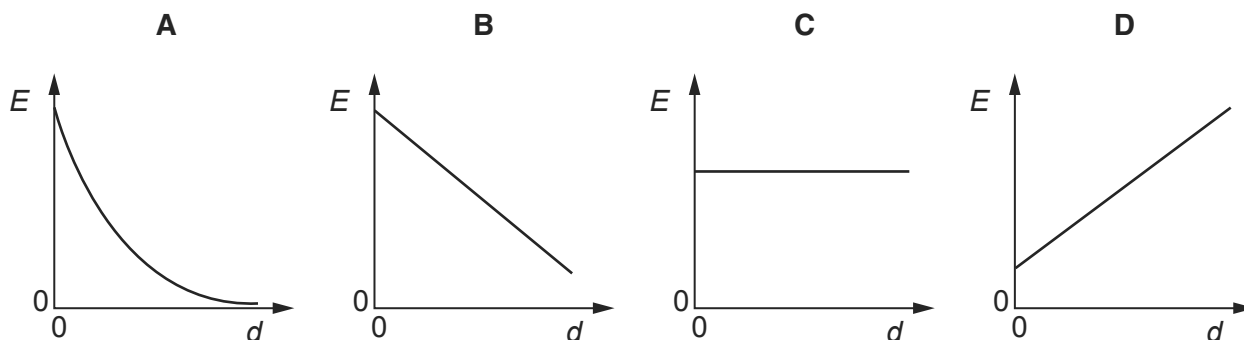

- 6 The diagram shows two metal plates P and Q between which there is a potential difference of 700 V. Plate Q is earthed.

9702/01/M/J/03/Q36

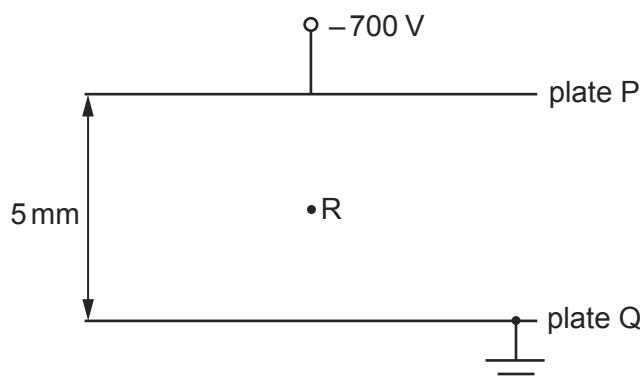

What is the magnitude and direction of the electric field at point R?

- A  $1.4 \times 10^2 \text{ N C}^{-1}$  from P towards Q  
 B  $1.4 \times 10^2 \text{ N C}^{-1}$  from Q towards P  
 C  $1.4 \times 10^5 \text{ N C}^{-1}$  from P towards Q  
 D  $1.4 \times 10^5 \text{ N C}^{-1}$  from Q towards P
- 7 The electric field strength between a pair of parallel plates is  $E$ . The separation of the plates is doubled and the potential difference between the plates is increased by a factor of four.

9702/01/M/J/07/Q30

What is the new electric field strength?

- A  $E$                       B  $2E$                       C  $4E$                       D  $8E$



- 8 Which diagram represents the electric field of a negative point charge  $-q$ ?

9702/01/O/N/03/Q35

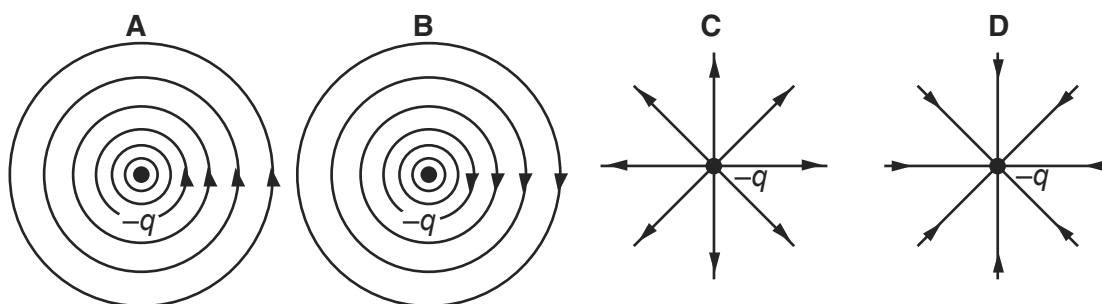

- 9 A potential difference  $V$  is applied between two parallel plates a small distance  $d$  apart, and produces an electric field of strength  $E$  between the plates.

9702/01/O/N/03/Q36

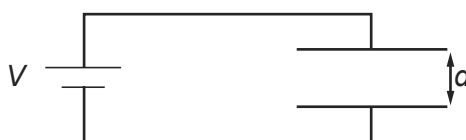

What is the electric field strength between the plates when both  $V$  and  $d$  are doubled?

- A**  $E/4$       **B**  $E$       **C**  $2E$       **D**  $4E$

- 10 In the circuit below, the distance between the two parallel plates is  $2.0 \times 10^{-3}$  m. An electron is situated between the plates.

9702/01/O/N/03/Q37

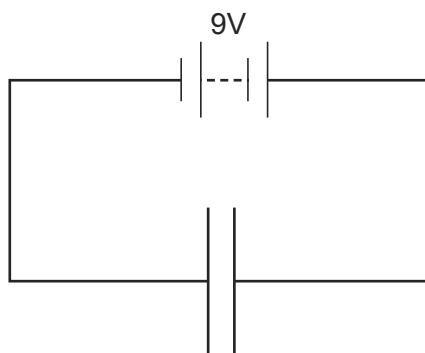

What is the force on the electron?

- A**  $3.2 \times 10^{-22}$  N  
**B**  $2.9 \times 10^{-21}$  N  
**C**  $8.9 \times 10^{-18}$  N  
**D**  $7.2 \times 10^{-16}$  N

- 11 What is an equivalent unit to 1 volt?

9702/01/M/J/04/Q32

- A**  $1\text{J A}^{-1}$       **B**  $1\text{J C}^{-1}$       **C**  $1\text{W C}^{-1}$       **D**  $1\text{W s}^{-1}$

- 12 The diagram shows an electron in a uniform electric field.

In which direction will the field accelerate the electron?

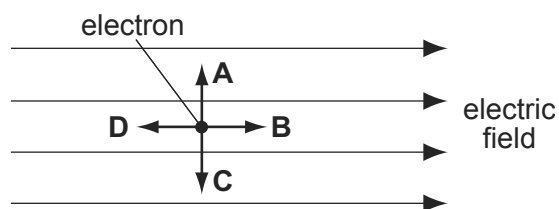

- 13 The diagram shows a thundercloud whose base is 500 m above the ground.

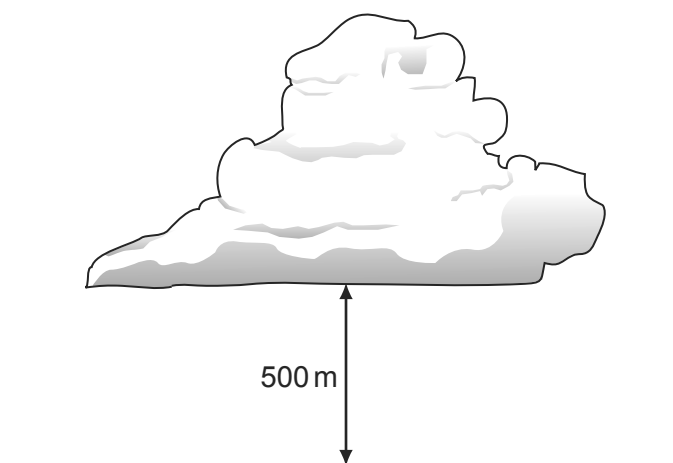

The potential difference between the base of the cloud and the ground is 200 MV. A raindrop with a charge of  $4.0 \times 10^{-12} \text{ C}$  is in the region between the cloud and the ground.

What is the electrical force on the raindrop?

- A**  $1.6 \times 10^{-6} \text{ N}$     **B**  $8.0 \times 10^{-4} \text{ N}$     **C**  $1.6 \times 10^{-3} \text{ N}$     **D**  $0.40 \text{ N}$
- 14 Two parallel, conducting plates with air between them are placed close to one another. The top plate is given a negative charge and the bottom one is earthed.

Which diagram best represents the distribution of charges and the field in this situation?

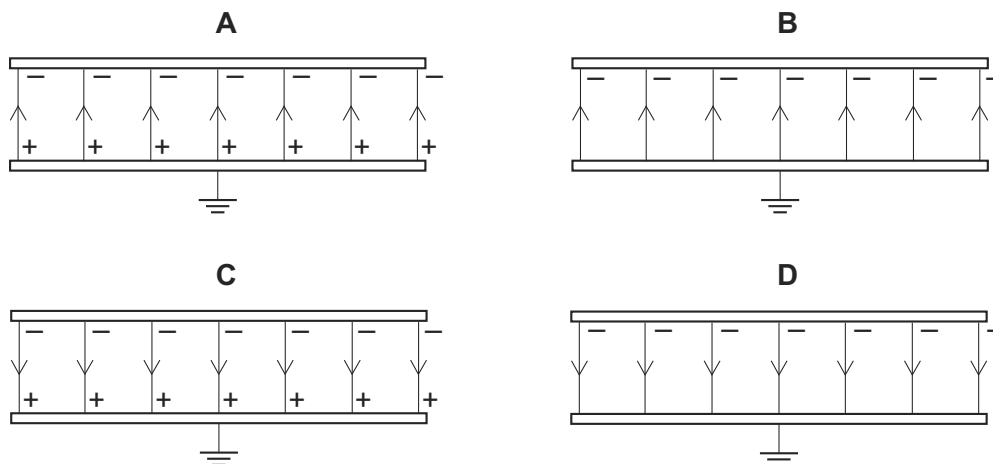

15 In a uniform electric field, which statement is correct?

9702/01/O/N/04/Q30

- A All charged particles experience the same force.
- B All charged particles move with the same velocity.
- C All electric field lines are directed towards positive charges.
- D All electric field lines are parallel.

16 Which of the following describes the electric potential difference between two points in a wire that carries a current?

9702/01/O/N/04/Q31

- A the force required to move a unit positive charge between the points
- B the ratio of the energy dissipated between the points to the current
- C the ratio of the power dissipated between the points to the current
- D the ratio of the power dissipated between the points to the charge moved

17 The diagram shows a pair of metal plates 4.0 mm apart connected to a 9.0 V battery. 9702/01/M/J/05/Q30

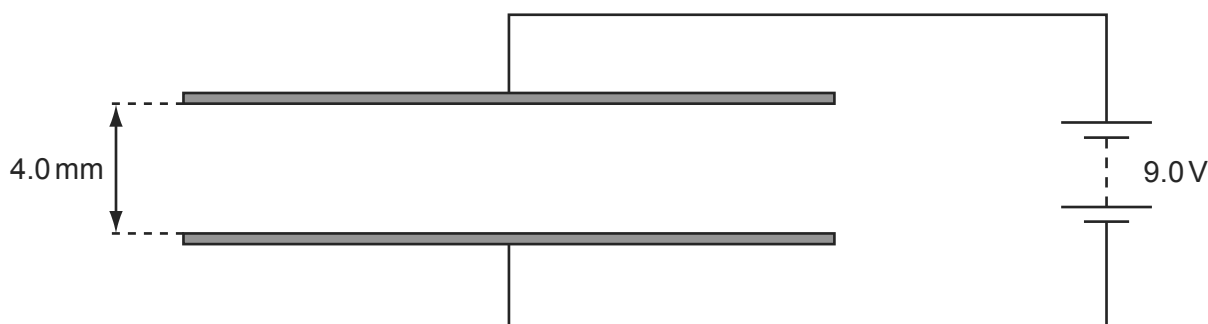

What is the electric field between the plates?

- A  $4.4 \times 10^{-4} \text{ NC}^{-1}$
- B  $3.6 \times 10^{-2} \text{ NC}^{-1}$
- C  $36 \text{ NC}^{-1}$
- D  $2.3 \times 10^3 \text{ NC}^{-1}$

18 Which diagram represents the electric field of a negative point charge, shown by ●? 9702/01/M/J/07/Q28

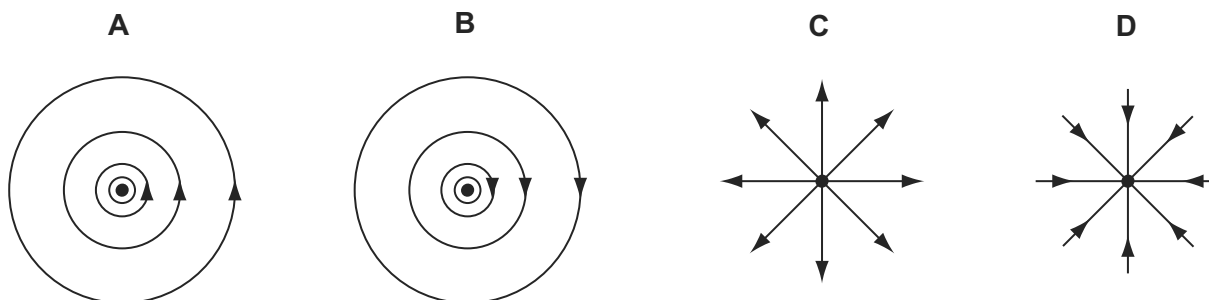

- 19 Which diagram represents the electric field in the vicinity of a positive electric charge of magnitude  $Q$ ?

9702/01/M/J/05/Q31

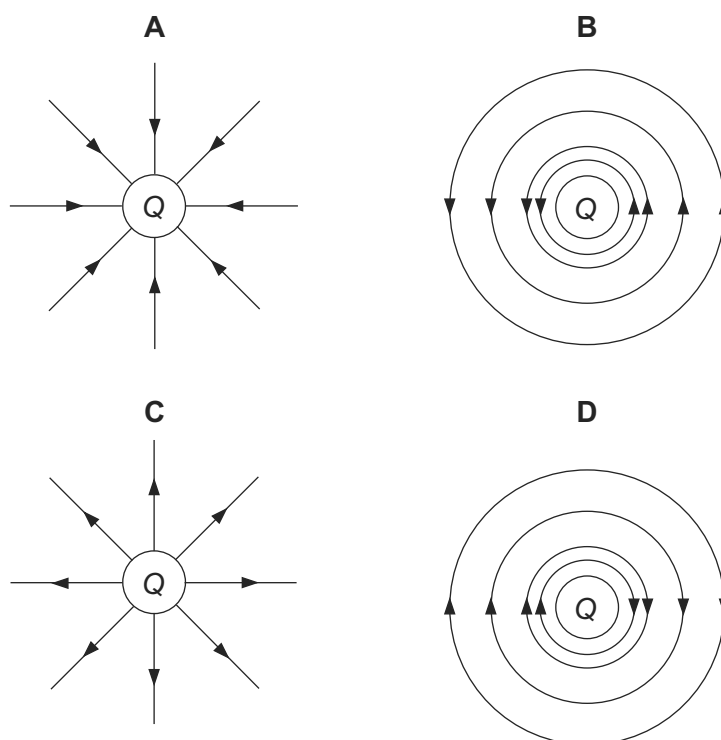

- 20 A positively charged particle is projected into a region of uniform electric field  $E$ .

9702/01/O/N/05/Q30

Which diagram represents the motion of the particle in the electric field?

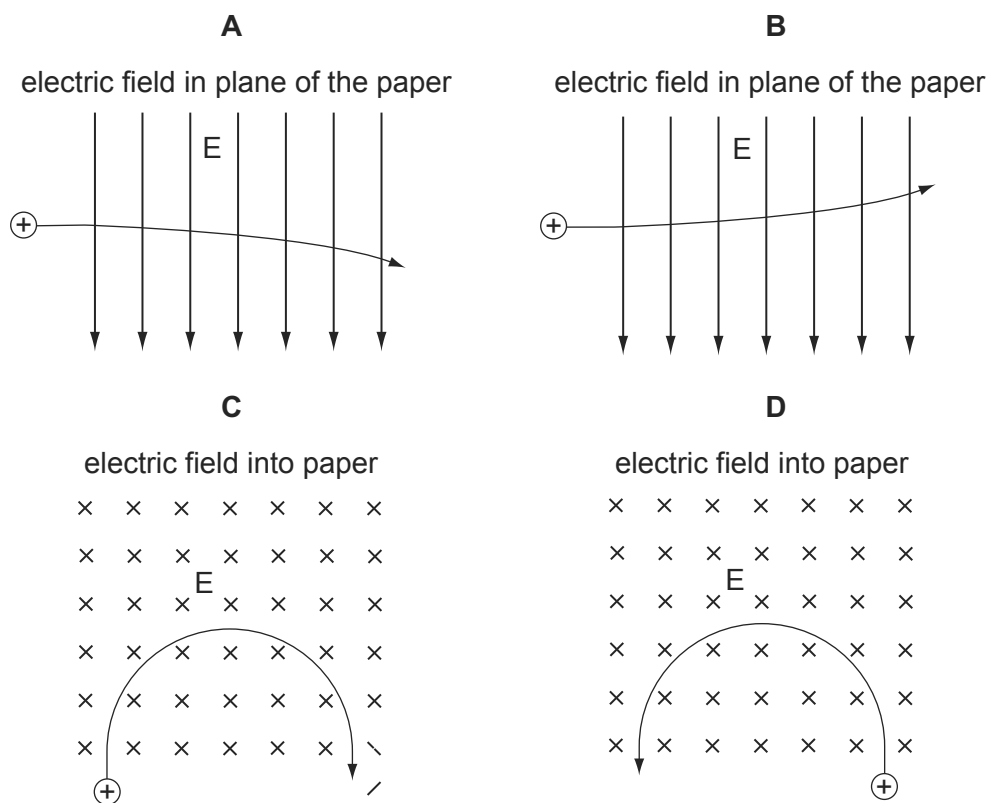

- 21 Two large parallel plates X and Z are placed 5.0 mm apart and connected as shown to the terminals of a 200 volt d.c. supply.

9702/01/O/N/05/Q31

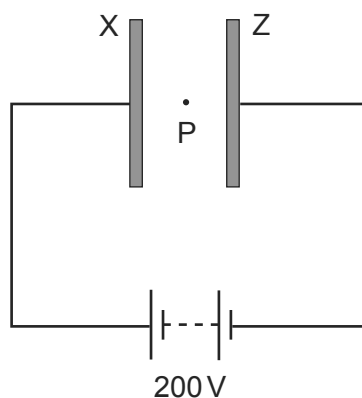

A small oil drop at P carries one excess electron.

What is the magnitude of the electrostatic force acting on the oil drop due to the electric field between the plates?

- A**  $6.4 \times 10^{-15}$  N  
**B**  $6.4 \times 10^{-18}$  N  
**C**  $1.6 \times 10^{-19}$  N  
**D**  $4.0 \times 10^{-24}$  N

- 22 An electric field exists in the space between two charged metal plates.

9702/01/O/N/06/Q30

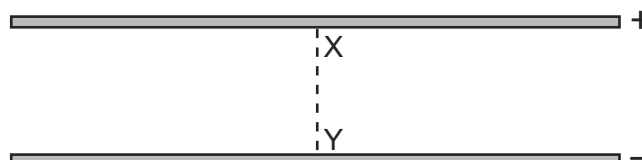

Which graph shows the variation of electric field strength  $E$  with distance  $d$  from X along the line XY?

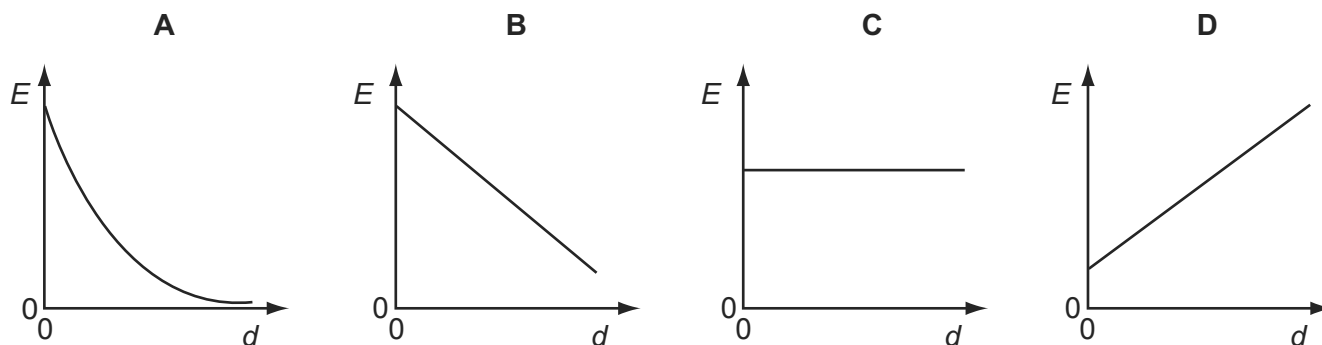

- 23 Two parallel metal plates are at potentials of +800 V and +1300 V.

9702/01/M/J/06/Q29

Which diagram best shows the electric field between the metal plates?

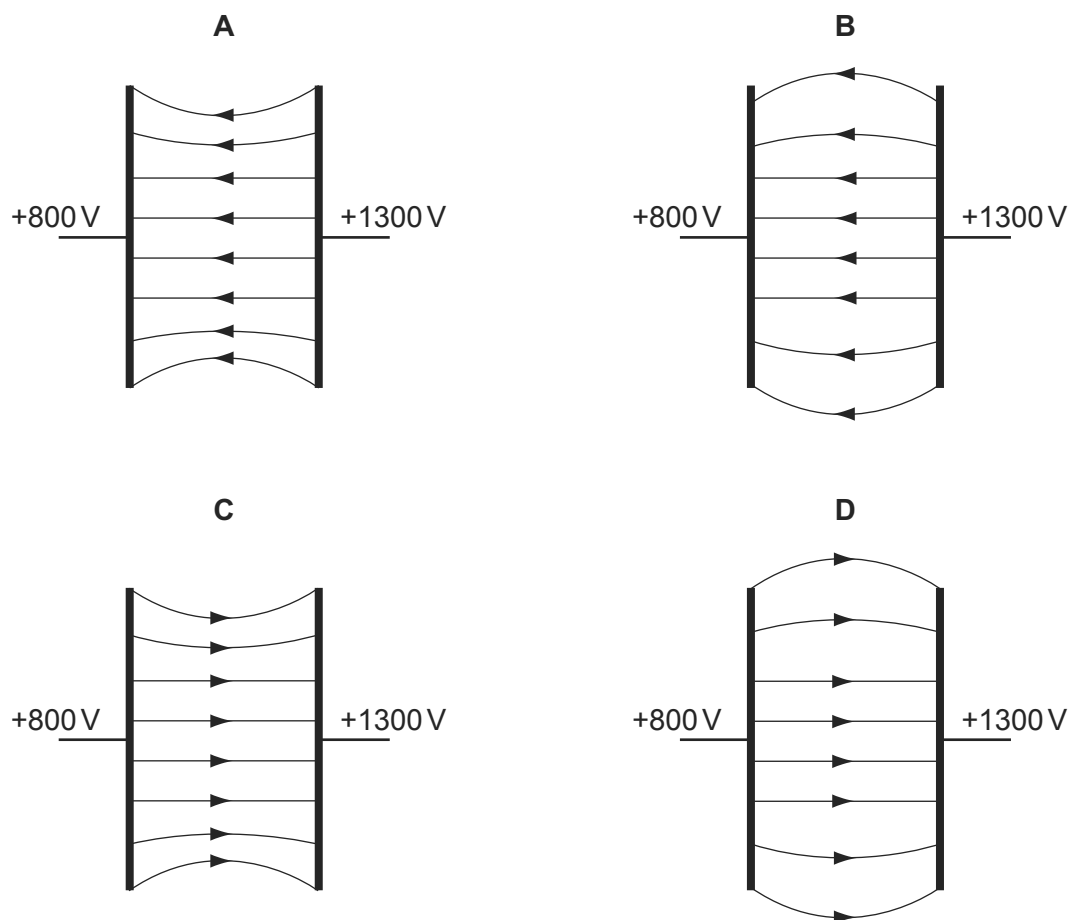

- 24 An electron of charge  $e$  is introduced between two metal plates a distance  $d$  apart. 9702/01/M/J/06/Q30

A potential difference  $V$  is applied to the plates as shown in the diagram.

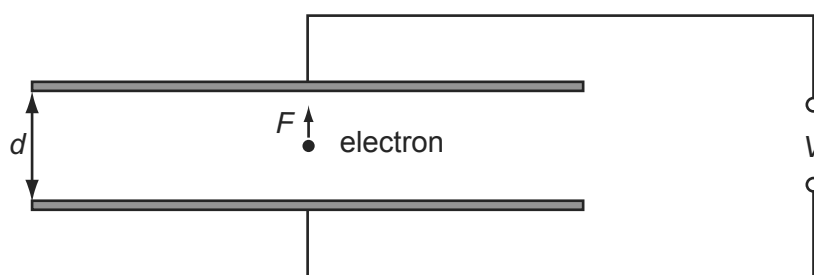

Which expression gives the electric force  $F$  on the electron?

- A  $\frac{eV}{d}$       B  $eVd$       C  $\frac{V}{ed}$       D  $\frac{dV}{e}$

- 25 Four point charges, each of charge  $Q$ , are placed on the edge of an insulating disc of radius  $r$ .

The frequency of rotation of the disc is  $f$ .

9702/01/O/N/06/Q31

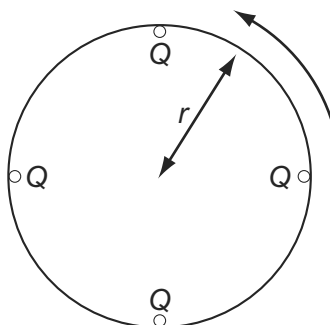

What is the equivalent electric current at the edge of the disc?

- A  $4Qf$       B  $\frac{4Q}{f}$       C  $8\pi rQf$       D  $\frac{2Qf}{\pi r}$
- 26 Which diagram shows the electric field pattern of an isolated negative point charge? 9702/01/O/N/06/Q29

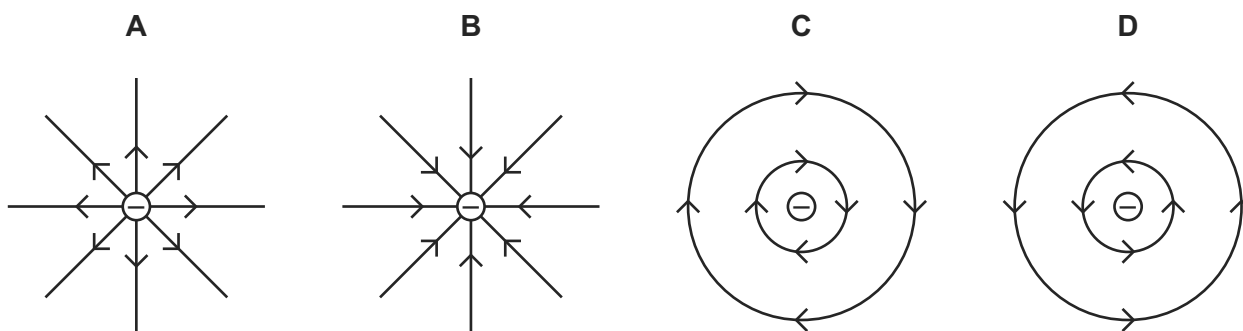

- 27 An electron is situated in a uniform electric field as shown in the diagram.

9702/01/O/N/07/Q26

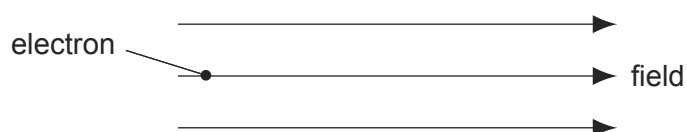

What is the direction of the electric force acting on the electron?

- A downwards into the paper  
 B upwards out of the paper  
 C to the left  
 D to the right

- 28 An electron, travelling horizontally at constant speed in a vacuum, enters a vertical electric field between two charged parallel plates as shown.

9702/01/M/J/07/Q29

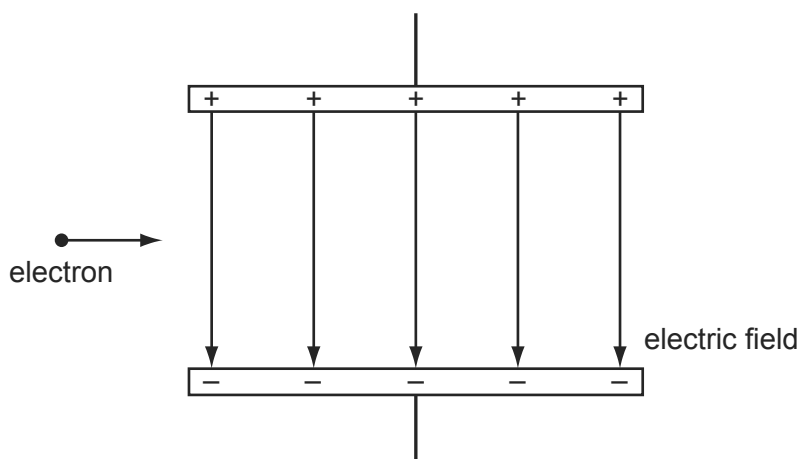

What are the horizontal and vertical components of the motion of this electron when it is in the field?

	horizontal component of motion	vertical component of motion
<b>A</b>	constant speed	acceleration upwards
<b>B</b>	constant speed	acceleration downwards
<b>C</b>	acceleration to the right	acceleration downwards
<b>D</b>	acceleration to the right	acceleration upwards

- 29 Which diagram shows the electric field between a positively charged metal sphere and an earthed metal plate?

9702/01/O/N/07/Q27

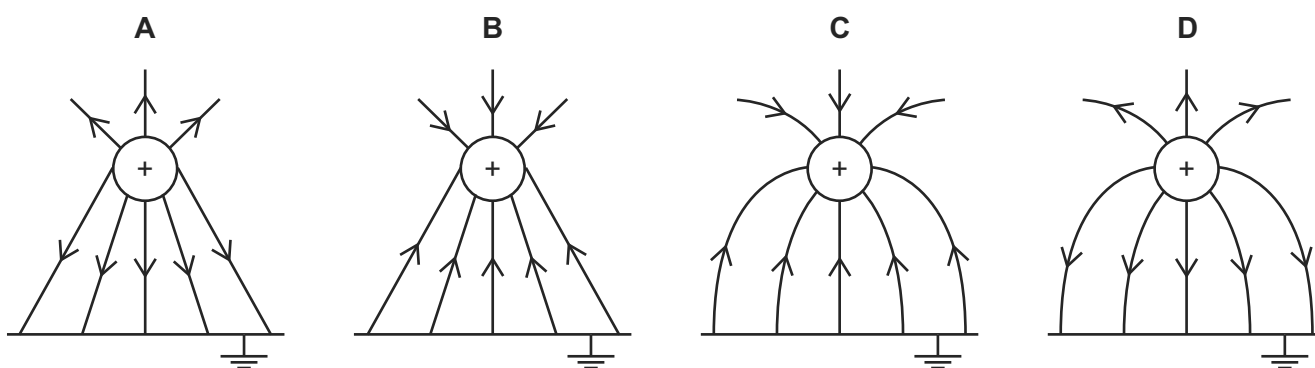



- 30 An electron enters the space between two parallel charged plates with an initial velocity  $u$ .

9702/01/M/J/08/Q30

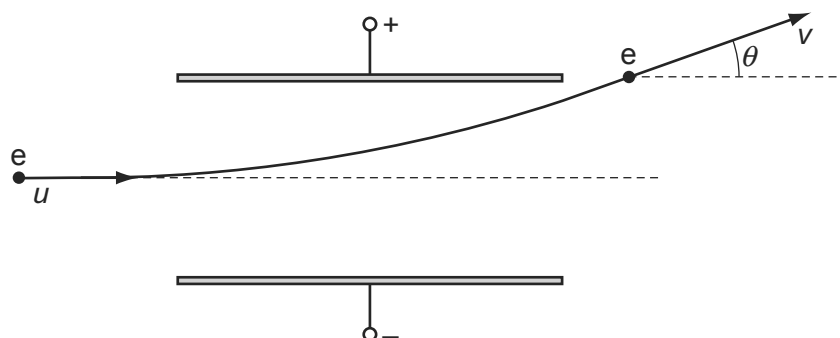

While in the electric field, its direction changes by  $\theta$  and it emerges with a velocity  $v$ .

What is the relation between  $v$  and  $u$ ?

- A**  $v = \frac{u}{\cos \theta}$       **B**  $v = u \cos \theta$       **C**  $v = \frac{u}{\sin \theta}$       **D**  $v = u \sin \theta$
- 31 Which electrical quantity would be the result of a calculation in which energy transfer is divided by charge?
- A** current  
**B** potential difference  
**C** power  
**D** resistance
- 32 The diagram shows an oil droplet that has become charged by gaining five electrons. The droplet remains stationary between charged plates.

9702/01/O/N/07/Q28

9702/01/M/J/08/Q31

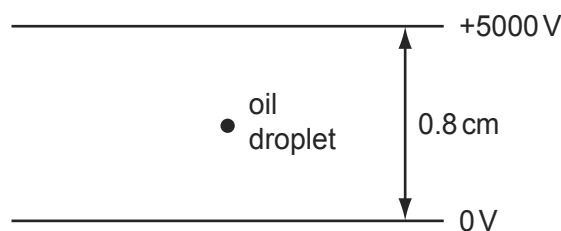

What is the magnitude and direction of the electrostatic force on the oil droplet?

- A**  $5.0 \times 10^{-15}$  N upwards  
**B**  $5.0 \times 10^{-15}$  N downwards  
**C**  $5.0 \times 10^{-13}$  N upwards  
**D**  $5.0 \times 10^{-13}$  N downwards

- 33 A particle has a charge of  $4.8 \times 10^{-19}$  C. The particle remains at rest between a pair of horizontal, parallel plates having a separation of 15 mm. The potential difference between the plates is 660 V.

9702/01/O/N/08/Q30

What is the weight of the particle?

- A**  $2.1 \times 10^{-14}$  N  
**B**  $2.1 \times 10^{-15}$  N  
**C**  $2.1 \times 10^{-17}$  N  
**D**  $1.1 \times 10^{-23}$  N
- 34 A small charge  $q$  is placed in the electric field of a large charge  $Q$ .

9702/11/O/N/09/Q27

Both charges experience a force  $F$ .

What is the electric field strength of the charge  $Q$  at the position of the charge  $q$ ?

- A**  $\frac{F}{Qq}$       **B**  $\frac{F}{Q}$       **C**  $FqQ$       **D**  $\frac{F}{q}$
- 35 The diagram shows the electric field near a point charge and two electrons X and Y.

9702/01/O/N/08/Q29

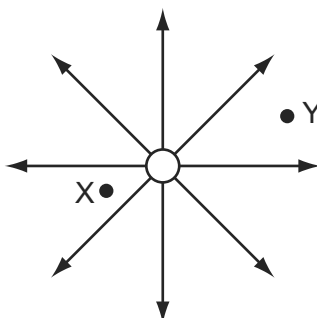

Which row describes the forces acting on X and Y?

	direction of force	magnitude of force on X
<b>A</b>	radially inwards	less than force on Y
<b>B</b>	radially inwards	greater than force on Y
<b>C</b>	radially outwards	less than force on Y
<b>D</b>	radially outwards	greater than force on Y

- 36 The diagram shows the paths of two charged particles, X and Y, during their passage between a pair of oppositely charged metal plates, P and Q. 9702/01/M/J/09/Q27

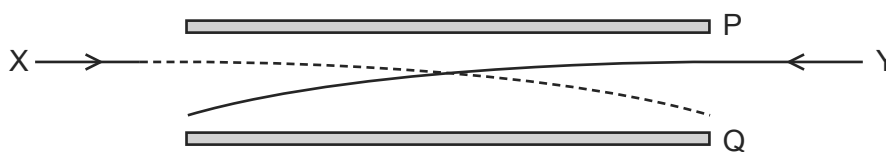

The plates are charged such that the electric field between them is directed from Q to P.

Which charges on X and Y will produce the observed paths?

	X	Y
<b>A</b>	-	-
<b>B</b>	-	+
<b>C</b>	+	-
<b>D</b>	+	+

- 37 There is a potential difference between a pair of parallel plates. 9702/01/M/J/09/Q28

Which values of potential difference and separation of the plates will produce an electric field strength of the greatest value?

	potential difference	separation
<b>A</b>	$2V$	$2d$
<b>B</b>	$2V$	$\frac{d}{2}$
<b>C</b>	$\frac{V}{2}$	$2d$
<b>D</b>	$\frac{V}{2}$	$\frac{d}{2}$

- 38 The electric field at a certain distance from an isolated alpha particle is  $3.0 \times 10^7 \text{ NC}^{-1}$ . 9702/11/O/N/09/Q29

What is the force on an electron when at that distance from the alpha particle?

- A**  $4.8 \times 10^{-12} \text{ N}$
- B**  $9.6 \times 10^{-12} \text{ N}$
- C**  $3.0 \times 10^7 \text{ N}$
- D**  $6.0 \times 10^7 \text{ N}$

- 39 The diagram shows an electron, with charge  $e$ , mass  $m$ , and velocity  $v$ , entering a uniform electric field of strength  $E$ .

9702/01/M/J/09/Q29

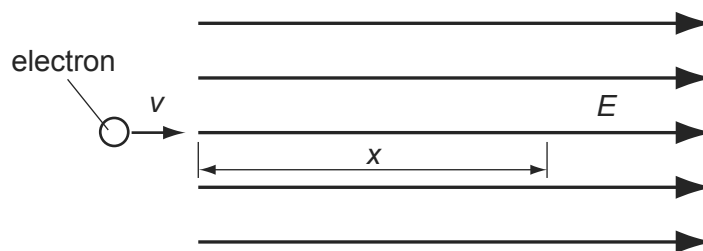

The direction of the field and the electron's motion are both horizontal and to the right.

Which expression gives the distance  $x$  through which the electron travels before it stops momentarily?

- A  $x = \frac{mv}{E}$       B  $x = \frac{mv}{Ee}$       C  $x = \frac{mv^2}{2E}$       D  $x = \frac{mv^2}{2Ee}$

- 40 The diagram shows two parallel horizontal metal plates held at a potential difference  $V$ .

9702/11/O/N/09/Q28

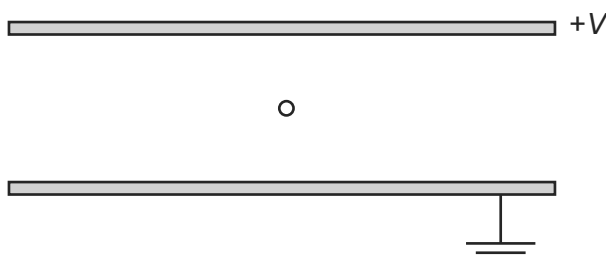

A small charged liquid drop, midway between the plates, is held in equilibrium by the combination of its weight and the electric force acting on it.

The acceleration of free fall is  $g$  and the electric field strength is  $E$ .

What is the ratio of the charge to mass of the drop, and the polarity of the charge on the drop?

	$\frac{\text{charge}}{\text{mass}}$	polarity
<b>A</b>	$\frac{g}{E}$	positive
<b>B</b>	$\frac{g}{E}$	negative
<b>C</b>	$\frac{E}{g}$	positive
<b>D</b>	$\frac{E}{g}$	negative

- 41 A small charge  $q$  is placed in the electric field of a large charge  $Q$ .

9702/12/O/N/09/Q26

Both charges experience a force  $F$ .

What is the electric field strength of the charge  $Q$  at the position of the charge  $q$ ?

- A**  $\frac{F}{Qq}$       **B**  $\frac{F}{Q}$       **C**  $FqQ$       **D**  $\frac{F}{q}$

- 42 The diagram shows two parallel horizontal metal plates held at a potential difference  $V$ .

9702/12/O/N/09/Q27

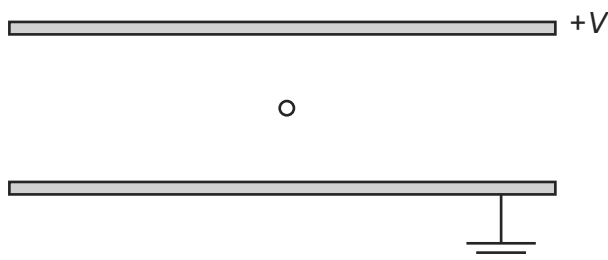

A small charged liquid drop, midway between the plates, is held in equilibrium by the combination of its weight and the electric force acting on it.

The acceleration of free fall is  $g$  and the electric field strength is  $E$ .

What is the ratio of the charge to mass of the drop, and the polarity of the charge on the drop?

	$\frac{\text{charge}}{\text{mass}}$	polarity
<b>A</b>	$\frac{g}{E}$	positive
<b>B</b>	$\frac{g}{E}$	negative
<b>C</b>	$\frac{E}{g}$	positive
<b>D</b>	$\frac{E}{g}$	negative

- 43 The electric field at a certain distance from an isolated alpha particle is  $3.0 \times 10^7 \text{ NC}^{-1}$ .

What is the force on an electron when at that distance from the alpha particle?

9702/12/O/N/09/Q28

- A**  $4.8 \times 10^{-12} \text{ N}$   
**B**  $9.6 \times 10^{-12} \text{ N}$   
**C**  $3.0 \times 10^7 \text{ N}$   
**D**  $6.0 \times 10^7 \text{ N}$

- 44 A cell is connected to a resistor.

9702/12/O/N/09/Q29

At any given moment, the potential difference across the cell is less than its electromotive force.

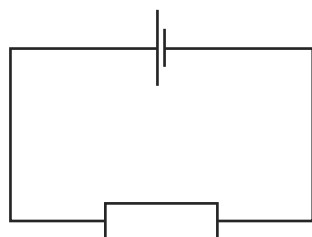

Which statement explains this?

- A The cell is continually discharging.
  - B The connecting wire has some resistance.
  - C Energy is needed to drive charge through the cell.
  - D Power is used when there is a current in the resistor.
- 45 Two oppositely-charged parallel plates are arranged as shown.

9702/11/M/J/10/Q28

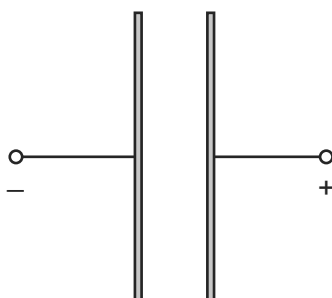

An electron is released from rest from the surface of the negatively-charged plate.

The electron travels from the negatively-charged plate towards the positively-charged plate.

Which graph shows how the force  $F$  on the electron varies with its distance  $x$  from the negative plate?

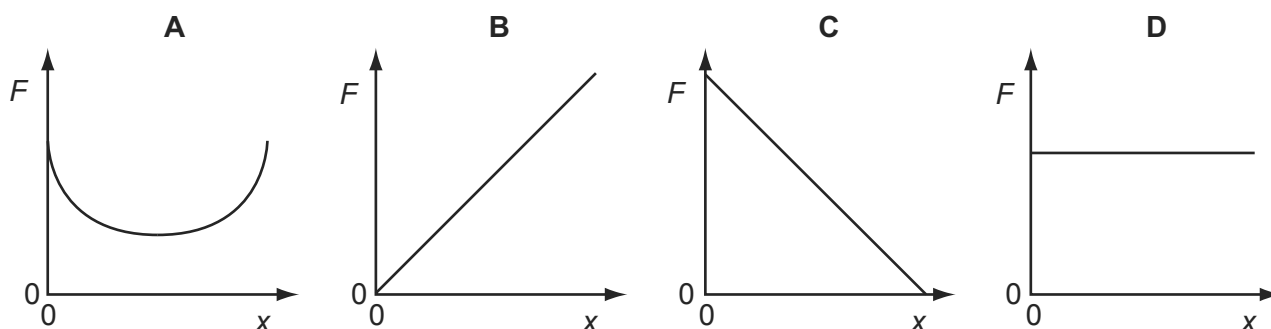

- 46 In the diagram, the shaded area represents a uniform electric field directed away from the observer (at right-angles into the plane of the paper). 9702/11/M/J/10/Q29

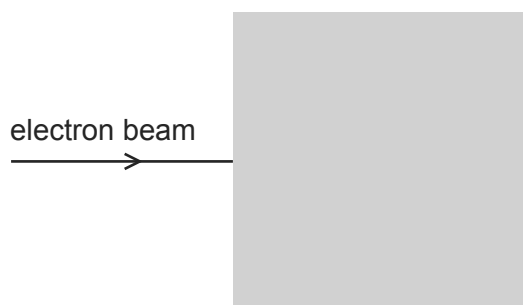

A horizontal beam of electrons enters the field, travelling from left to right.

In which direction is this beam deflected by the field?

- A** upwards (in the plane of the paper)
  - B** downwards (in the plane of the paper)
  - C** away from the observer
  - D** towards the observer
- 47 Two oppositely-charged parallel plates are arranged as shown. 9702/12/M/J/10/Q26

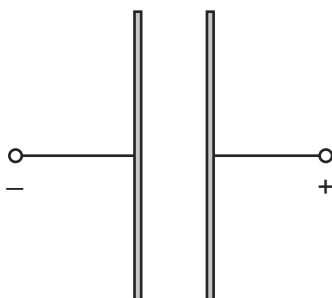

An electron is released from rest from the surface of the negatively-charged plate.

The electron travels from the negatively-charged plate towards the positively-charged plate.

Which graph shows how the force  $F$  on the electron varies with its distance  $x$  from the negative plate?

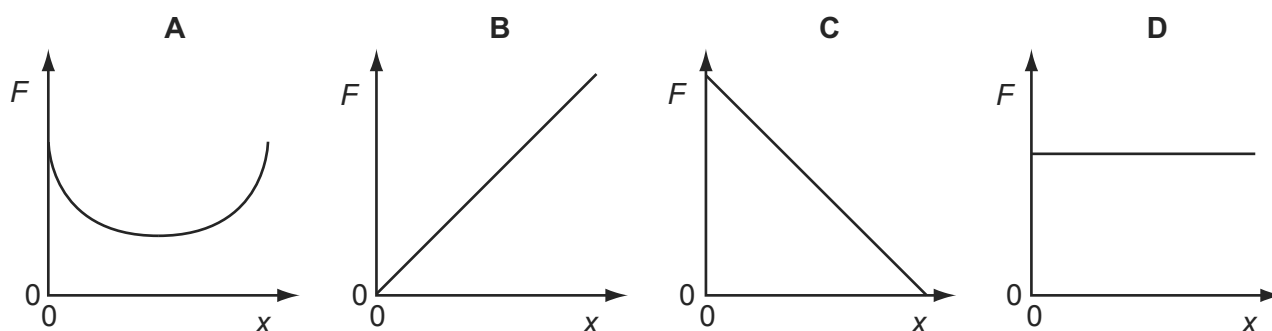

- 48 In the diagram, the shaded area represents a uniform electric field directed away from the observer (at right-angles into the plane of the paper). 9702/12/M/J/10/Q27

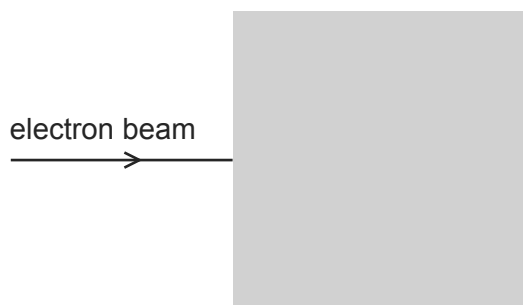

A horizontal beam of electrons enters the field, travelling from left to right.

In which direction is this beam deflected by the field?

- A** upwards (in the plane of the paper)  
**B** downwards (in the plane of the paper)  
**C** away from the observer  
**D** towards the observer
- 49 The diagram shows two points P and Q which lie,  $90^\circ$  apart, on a circle of radius  $r$ . 9702/12/M/J/10/Q28

A positive point charge at the centre of the circle creates an electric field of magnitude  $E$  at both P and Q.

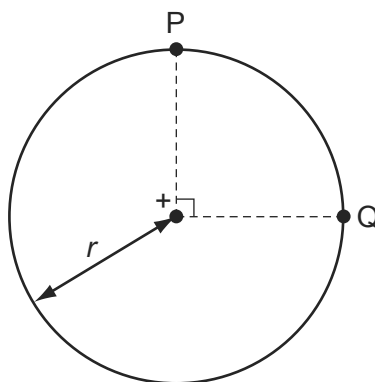

Which expression gives the work done in moving a unit positive charge from P to Q?

- A** 0                      **B**  $E \times r$                       **C**  $E \times \left(\frac{\pi r}{2}\right)$                       **D**  $E \times (\pi r)$
- 50 When will 1 C of charge pass a point in an electrical circuit? 9702/12/M/J/12/Q32
- A** when 1 A moves through a potential difference of 1 V  
**B** when a power of 1 W is used for 1 s  
**C** when the current is 5 mA for 200 s  
**D** when the current is 10 A for 10 s



- 51 Which row describes the circumstances under which forces act on a charged particle in a uniform electric field?

9702/12/M/J/10/Q29

	charged particle	direction of force
<b>A</b>	moving charges only	parallel to the field
<b>B</b>	stationary charges only	perpendicular to the field
<b>C</b>	stationary and moving charges	parallel to the field
<b>D</b>	stationary and moving charges	perpendicular to the field

- 52 In the diagram, the shaded area represents a uniform electric field directed away from the observer (at right-angles into the plane of the paper).

9702/13/M/J/10/Q26

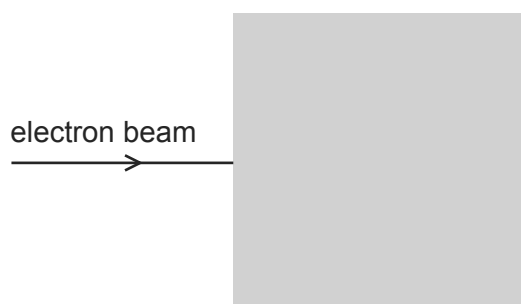

A horizontal beam of electrons enters the field, travelling from left to right.

In which direction is this beam deflected by the field?

- A** upwards (in the plane of the paper)  
**B** downwards (in the plane of the paper)  
**C** away from the observer  
**D** towards the observer
- 53 An electron is in an electric field of strength  $5 \times 10^4 \text{ V m}^{-1}$ . The field is the only influence on the electron.

9702/11/O/N/10/Q28

The mass and charge of an electron are known.

Which quantity can be calculated without any more information?

- A** the force on the electron  
**B** the momentum of the electron  
**C** the kinetic energy of the electron  
**D** the speed of the electron

54 Two oppositely-charged parallel plates are arranged as shown.

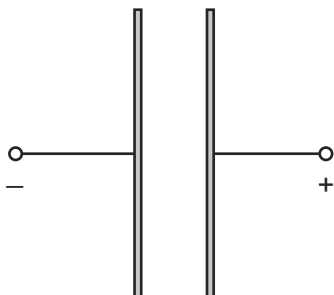

An electron is released from rest from the surface of the negatively-charged plate.

The electron travels from the negatively-charged plate towards the positively-charged plate.

Which graph shows how the force  $F$  on the electron varies with its distance  $x$  from the negative plate?

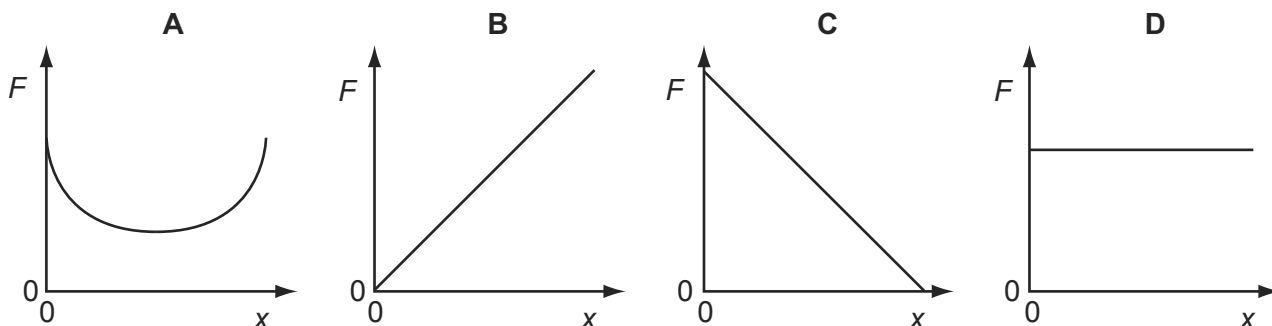

55 Which path shows a possible movement of an electron in the electric field shown? 9702/12/O/N/11/Q30

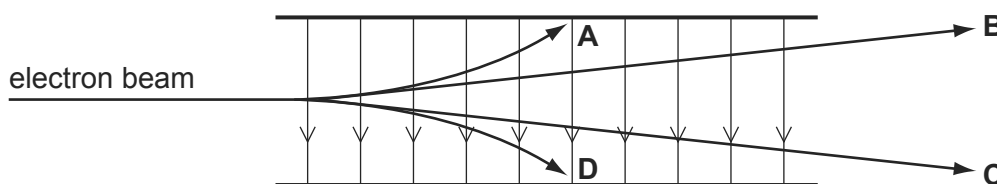

56 Which row describes the circumstances under which forces act on a charged particle in a uniform electric field?

9702/13/M/J/10/Q28

	charged particle	direction of force
<b>A</b>	moving charges only	parallel to the field
<b>B</b>	stationary charges only	perpendicular to the field
<b>C</b>	stationary and moving charges	parallel to the field
<b>D</b>	stationary and moving charges	perpendicular to the field

- 57 The diagram shows two points P and Q which lie,  $90^\circ$  apart, on a circle of radius  $r$ . 9702/13/M/J/10/Q29

A positive point charge at the centre of the circle creates an electric field of magnitude  $E$  at both P and Q.

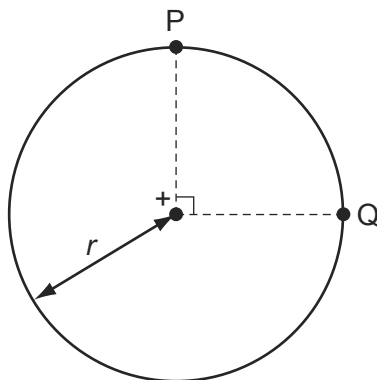

Which expression gives the work done in moving a unit positive charge from P to Q?

- A 0                      B  $E \times r$                       C  $E \times \left(\frac{\pi r}{2}\right)$                       D  $E \times (\pi r)$

- 58 The diagram shows a charged particle as it approaches a pair of charged parallel plates in a vacuum. 9702/13/M/J/11/Q30

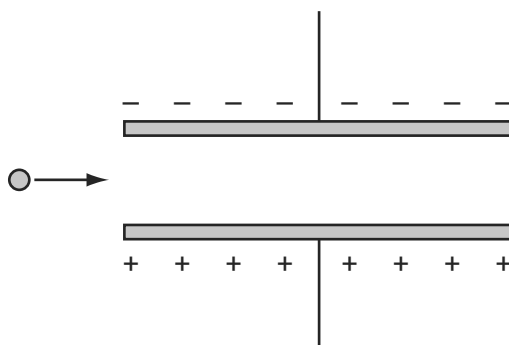

Which row describes the horizontal and vertical components of its motion as it travels between the plates?

	horizontal component	vertical component
<b>A</b>	constant acceleration	constant acceleration
<b>B</b>	constant acceleration	constant velocity
<b>C</b>	constant velocity	constant acceleration
<b>D</b>	constant velocity	constant velocity

- 59 Electrons are accelerated and then directed into the uniform electric field between two parallel plates in a vacuum.

9702/11/O/N/10/Q29

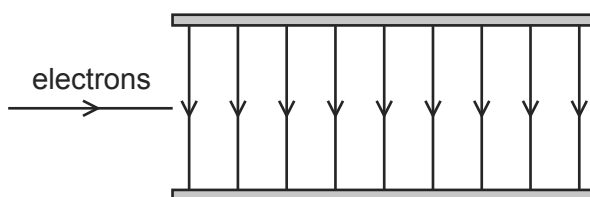

What best describes the shape of the path followed by the electrons in the field?

- A** a downwards curve along a line that is part of a circle  
**B** a downwards curve along a line that is **not** part of a circle  
**C** an upwards curve along a line that is part of a circle  
**D** an upwards curve along a line that is **not** part of a circle
- 60 A charged particle is in the electric field between two horizontal metal plates connected to a source of constant potential difference, as shown. There is a force  $F$  on the particle due to the electric field.

9702/11/O/N/10/Q30

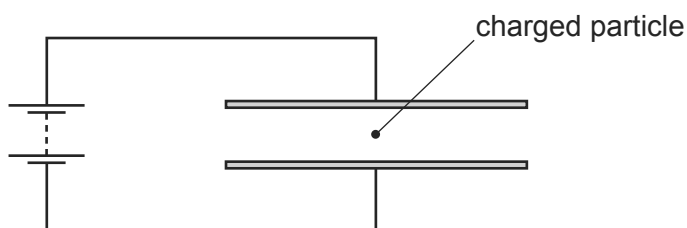

The separation of the plates is doubled.

What will be the new force on the particle?

- A**  $\frac{F}{4}$       **B**  $\frac{F}{2}$       **C**  $F$       **D**  $2F$
- 61 What describes the electric potential difference between two points in a wire that carries a current?

9702/12/M/J/11/Q32

- A** the force required to move a unit positive charge between the points  
**B** the ratio of the energy dissipated between the points to the current  
**C** the ratio of the power dissipated between the points to the current  
**D** the ratio of the power dissipated between the points to the charge moved

62 The diagram shows a vertical uniform electric field in a vacuum.

9702/12/O/N/10/Q28

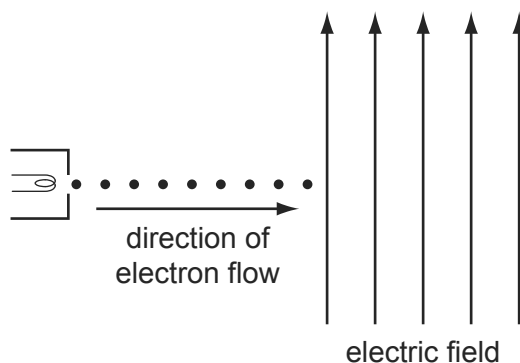

An electron gun injects a beam of electrons horizontally into the field.

Which changes, if any, have occurred to the path and speed of the electrons by the time the beam leaves the field?

	path of electrons	speed of electrons
<b>A</b>	deflected downwards	increased
<b>B</b>	deflected downwards	unchanged
<b>C</b>	deflected upwards	increased
<b>D</b>	deflected upwards	unchanged

63 A very small oil drop of mass  $m$  carries a charge  $+q$ .

9702/12/O/N/10/Q29

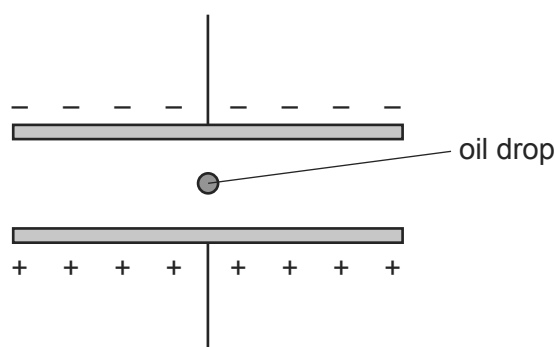

The potential difference across the plates is  $V$  and the separation is  $d$ .

The weight of the drop is balanced by the electric force. (Buoyancy forces may be considered to be negligible.)

Which formula gives the charge on the drop?

**A**  $q = \frac{mgd}{V}$       **B**  $q = \frac{mgV}{d}$       **C**  $q = \frac{Vd}{mg}$       **D**  $q = \frac{V}{mgd}$

- 64 Electrons are accelerated and then directed into the uniform electric field between two parallel plates in a vacuum.

9702/13/O/N/10/Q28

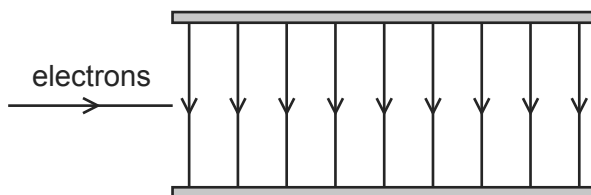

What best describes the shape of the path followed by the electrons in the field?

- A** a downwards curve along a line that is part of a circle  
**B** a downwards curve along a line that is **not** part of a circle  
**C** an upwards curve along a line that is part of a circle  
**D** an upwards curve along a line that is **not** part of a circle
- 65 A charged particle is in the electric field between two horizontal metal plates connected to a source of constant potential difference, as shown. There is a force  $F$  on the particle due to the electric field.

9702/13/O/N/10/Q29

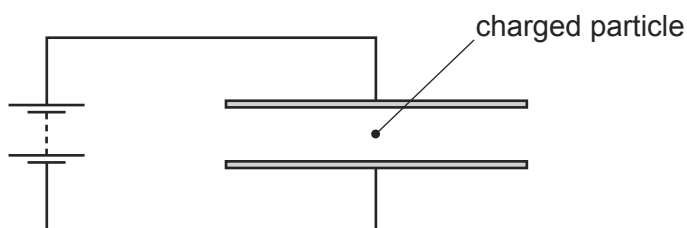

The separation of the plates is doubled.

What will be the new force on the particle?

- A**  $\frac{F}{4}$       **B**  $\frac{F}{2}$       **C**  $F$       **D**  $2F$
- 66 An electron is in an electric field of strength  $5 \times 10^4 \text{ V m}^{-1}$ . The field is the only influence on the electron.

9702/13/O/N/10/Q30

The mass and charge of an electron are known.

Which quantity can be calculated without any more information?

- A** the force on the electron  
**B** the momentum of the electron  
**C** the kinetic energy of the electron  
**D** the speed of the electron

67 A potential difference is applied between two metal plates that are **not** parallel.

9702/11/M/J/11/Q28

Which diagram shows the electric field between the plates?

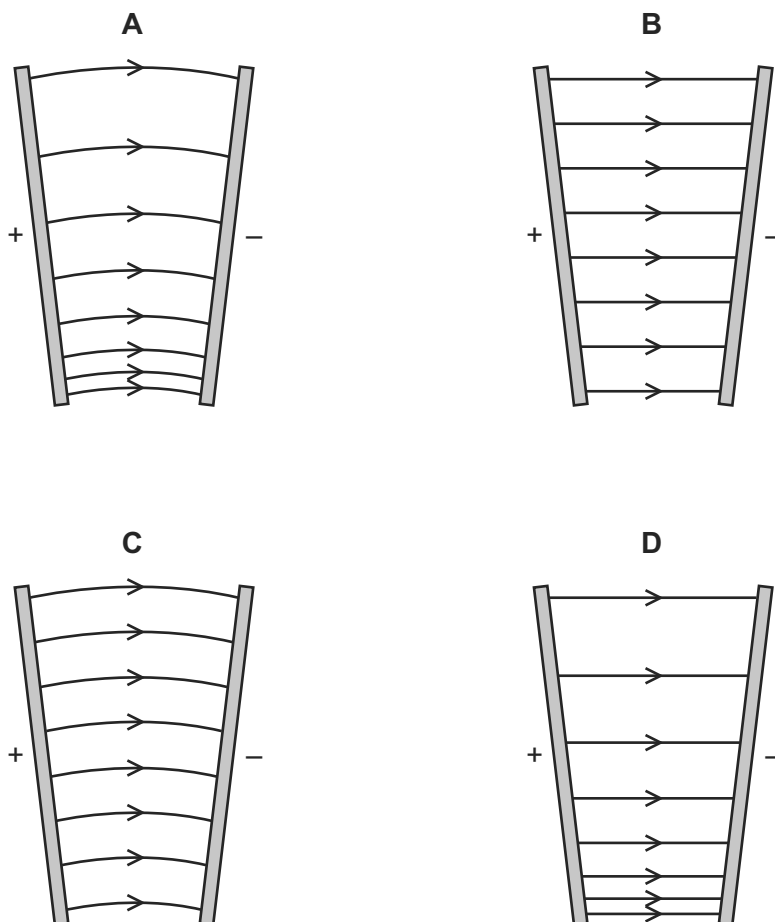

68 The diagram shows two parallel metal plates connected to a d.c. power supply through a resistor.

9702/12/M/J/11/Q30

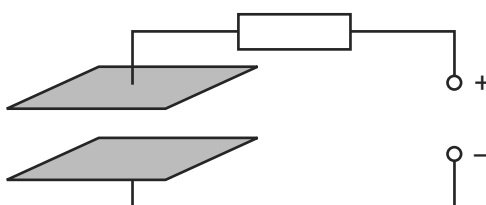

There is a uniform electric field in the region between the plates.

Which change would cause a **decrease** in the strength of the electric field?

- A a small increase in the distance between the plates
- B a small increase in the potential difference between the plates
- C a small increase in the value of the resistor
- D a small increase to the area of both plates

- 69 The diagram shows a charged particle as it approaches a pair of charged parallel plates in a vacuum.

9702/11/M/J/11/Q29

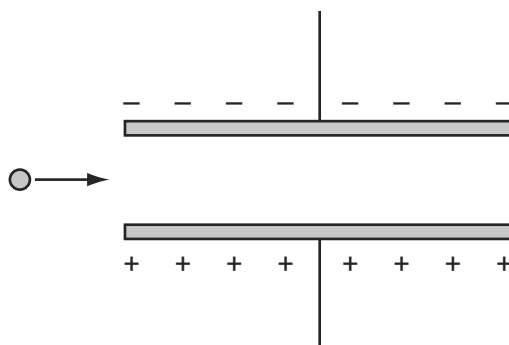

Which row describes the horizontal and vertical components of its motion as it travels between the plates?

	horizontal component	vertical component
<b>A</b>	constant acceleration	constant acceleration
<b>B</b>	constant acceleration	constant velocity
<b>C</b>	constant velocity	constant acceleration
<b>D</b>	constant velocity	constant velocity

- 70 Two parallel plates, a distance 25 mm apart, have a potential difference between them of 12 kV.

9702/11/M/J/11/Q30

What is the force on an electron when it is in the uniform electric field between the plates?

- A**  $4.8 \times 10^{-20} \text{ N}$   
**B**  $7.7 \times 10^{-20} \text{ N}$   
**C**  $4.8 \times 10^{-17} \text{ N}$   
**D**  $7.7 \times 10^{-14} \text{ N}$

- 71 A battery is marked 9.0 V.

9702/13/M/J/11/Q31

What does this mean?

- A** Each coulomb of charge from the battery supplies 9.0 J of electrical energy to the whole circuit.  
**B** The battery supplies 9.0 J to an external circuit for each coulomb of charge.  
**C** The potential difference across any component connected to the battery will be 9.0 V.  
**D** There will always be 9.0 V across the battery terminals.



72 In each electric field diagram, a positively charged particle is moved from X to Y.

9702/12/M/J/11/Q31

In which diagram would the particle experience an increasing repulsive force?

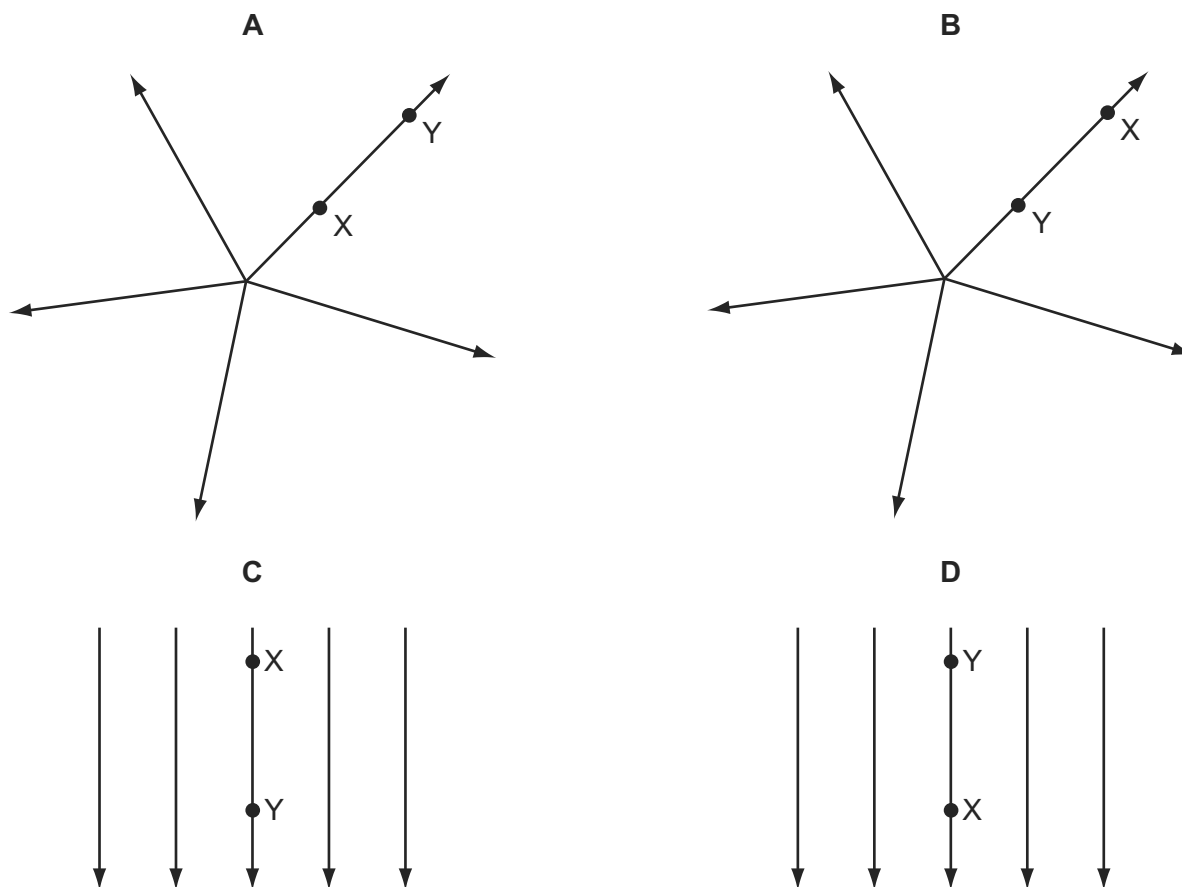

73 The diagram shows a pair of parallel metal plates 4.0 mm apart connected to a 9.0 V battery.

9702/12/O/N/11/Q29

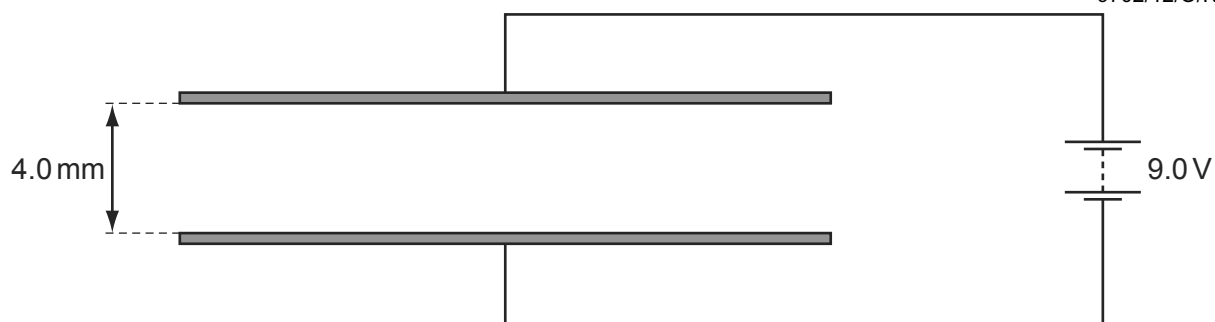

What is the electric field strength between the plates?

- A  $4.4 \times 10^{-4} \text{ NC}^{-1}$
- B  $3.6 \times 10^{-2} \text{ NC}^{-1}$
- C  $36 \text{ NC}^{-1}$
- D  $2.3 \times 10^3 \text{ NC}^{-1}$

74 A potential difference is applied between two metal plates that are **not** parallel.

9702/13/M/J/11/Q29

Which diagram shows the electric field between the plates?

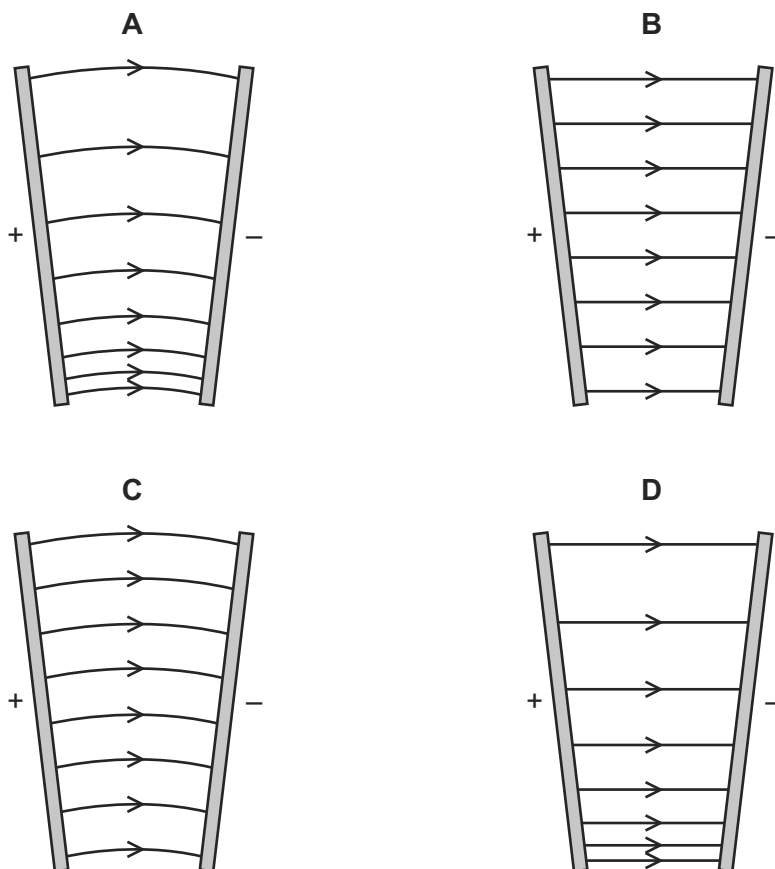

75 The diagram shows an insulating rod with equal and opposite point charges at each end. An electric field of strength  $E$  acts on the rod in a downwards direction.

9702/11/O/N/11/Q32

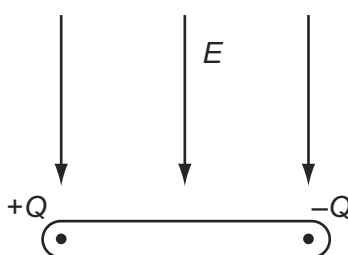

Which row is correct?

	resultant force	resultant torque
<b>A</b>	zero	clockwise
<b>B</b>	downwards	clockwise
<b>C</b>	zero	anti-clockwise
<b>D</b>	downwards	anti-clockwise

- 76 The diagram shows a non-uniform electric field near a positively charged and a negatively charged sphere.

9702/12/O/N/11/Q31

Four electrons, **A**, **B**, **C** and **D**, are shown at different positions in the field.

On which electron is the direction of the force on the electron shown correctly?

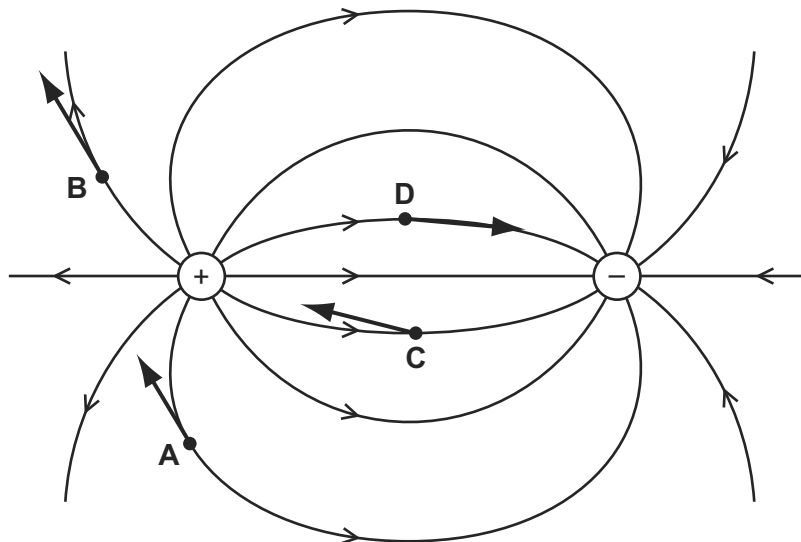

- 77 The diagram shows an insulating rod with equal and opposite point charges at each end. An electric field of strength  $E$  acts on the rod in a downwards direction.

9702/13/O/N/11/Q31

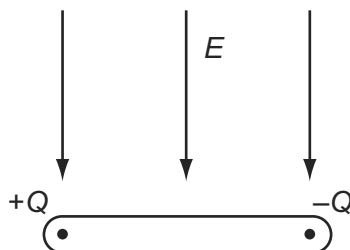

Which row is correct?

	resultant force	resultant torque
<b>A</b>	zero	clockwise
<b>B</b>	downwards	clockwise
<b>C</b>	zero	anti-clockwise
<b>D</b>	downwards	anti-clockwise

- 78 A dipole is a pair of one negative charge and one positive charge of equal magnitude. The electric field of a dipole is shown below.

9702/11/M/J/12/Q31

In which direction does the force act on an electron when at point X?

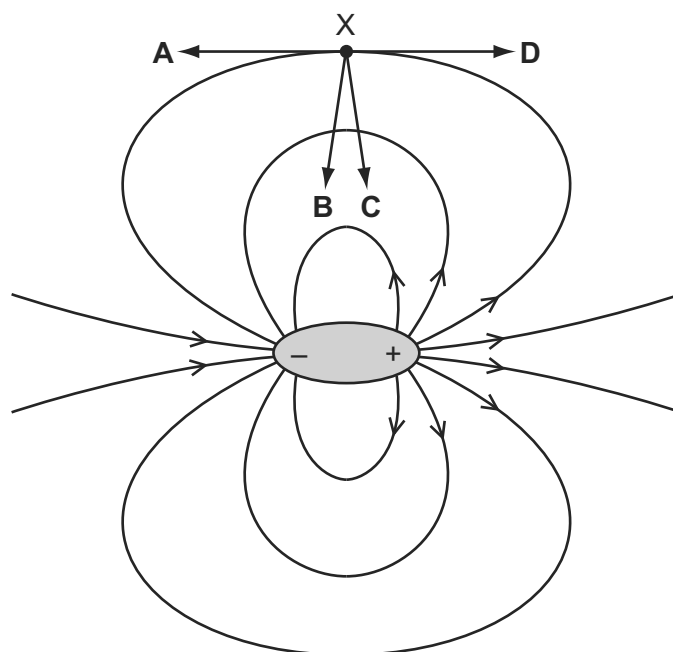

- 79 Lightning can occur between a charged cloud and the Earth's surface when the electric field strength in the intervening atmosphere reaches  $25 \text{ kNC}^{-1}$ . The diagram shows the electric field between the base of a cloud and the Earth's surface.

9702/11/M/J/12/Q32

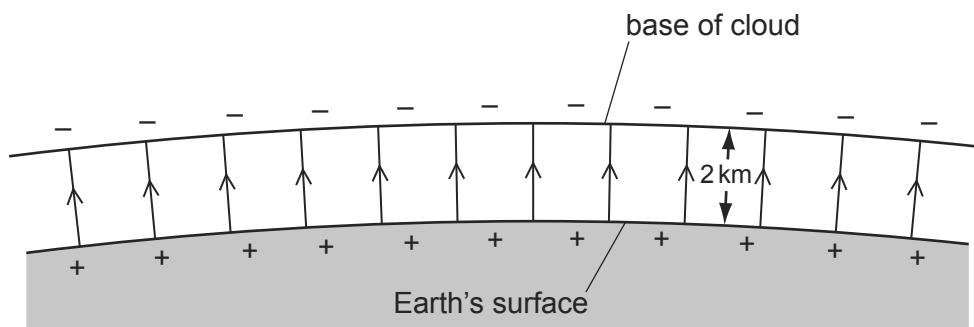

What is the minimum potential difference between the Earth and the base of a cloud, 2 km high, for lightning to occur?

- A** 12.5 MV      **B** 25 MV      **C** 50 MV      **D** 100 MV

80 An electric field exists in the space between two charged metal plates.

9702/12/M/J/12/Q31

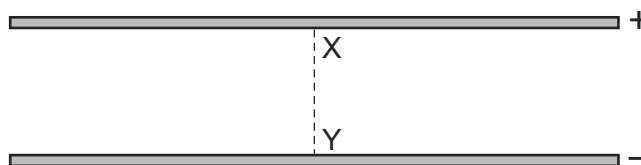

Which graph shows the variation of electric field strength  $E$  with distance  $d$  from X along the line XY?

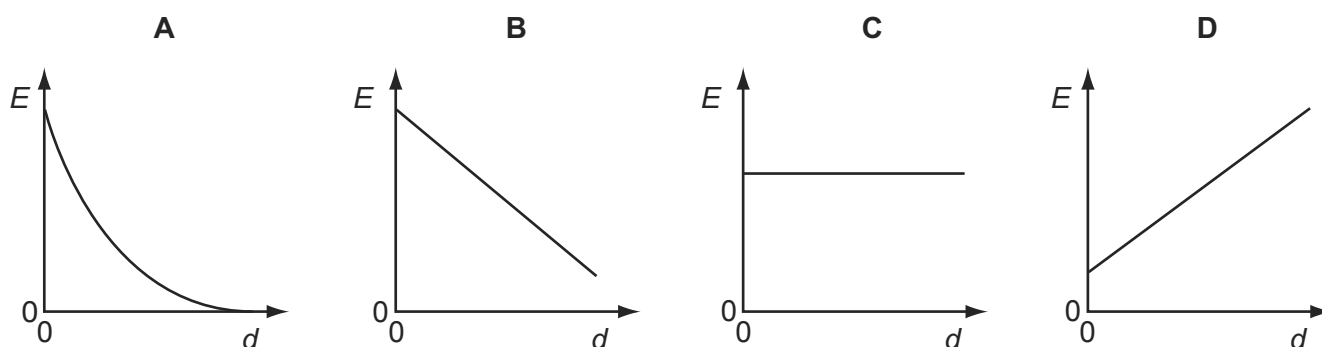

81 Two horizontal parallel plate conductors are separated by a distance of 5.0 mm in air. The lower plate is earthed and the potential of the upper plate is +50 V.

9702/13/O/N/11/Q32

What is the electric field strength  $E$  at a point midway between the plates?

- A  $1.0 \times 10^4 \text{ V m}^{-1}$  downwards
- B  $1.0 \times 10^4 \text{ V m}^{-1}$  upwards
- C  $2.0 \times 10^4 \text{ V m}^{-1}$  downwards
- D  $2.0 \times 10^4 \text{ V m}^{-1}$  upwards

82 Two horizontal parallel plate conductors are separated by a distance of 5.0 mm in air. The lower plate is earthed and the potential of the upper plate is +50 V.

9702/11/O/N/11/Q31

What is the electric field strength  $E$  at a point midway between the plates?

- A  $1.0 \times 10^4 \text{ V m}^{-1}$  downwards
- B  $1.0 \times 10^4 \text{ V m}^{-1}$  upwards
- C  $2.0 \times 10^4 \text{ V m}^{-1}$  downwards
- D  $2.0 \times 10^4 \text{ V m}^{-1}$  upwards

- 83 Lightning can occur between a charged cloud and the Earth's surface when the electric field strength in the intervening atmosphere reaches  $25 \text{ kNC}^{-1}$ . The diagram shows the electric field between the base of a cloud and the Earth's surface.

9702/13/M/J/12/Q33

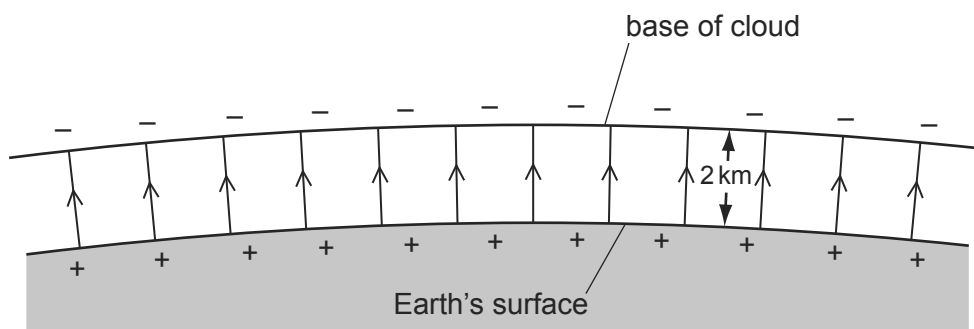

What is the minimum potential difference between the Earth and the base of a cloud, 2 km high, for lightning to occur?

- A 12.5 MV      B 25 MV      C 50 MV      D 100 MV
- 84 A dipole is a pair of one negative charge and one positive charge of equal magnitude. The electric field of a dipole is shown below.

9702/13/M/J/12/Q31

In which direction does the force act on an electron when at point X?

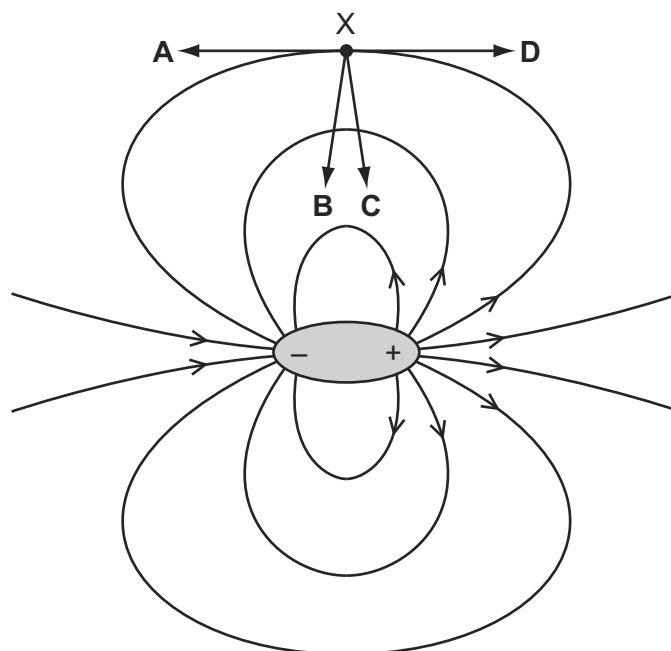

- 85 A single proton travelling with a constant horizontal velocity enters a uniform electric field between two parallel charged plates. In the diagram, **B** shows the path taken by the proton.

Which path is taken by a helium nucleus that enters the electric field at the same point and with the same velocity as the proton?

9702/12/O/N/12/Q33

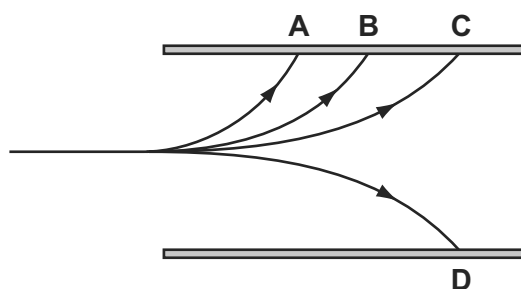

- 86 A charged particle moves in a uniform electric field between two parallel metal plates.

To calculate the force acting on the particle due to the electric field, which quantity is **not** required?

9702/12/O/N/12/Q32

- A** particle charge
- B** particle speed
- C** plate separation
- D** potential difference between the plates

- 87 An electron is initially at rest in a uniform electric field.

9702/11/O/N/12/Q30

Which graph shows the variation with time of the velocity of the electron?

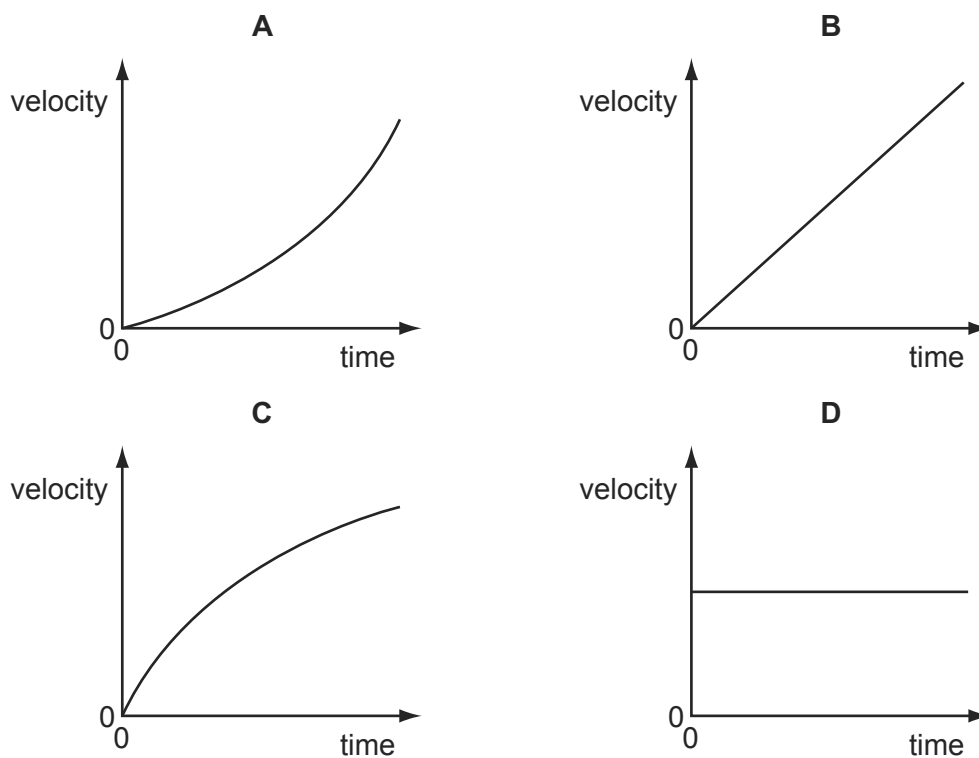

- 88 A charged particle is in the electric field between two horizontal metal plates connected to a source of constant potential difference, as shown.

9702/11/O/N/12/Q31

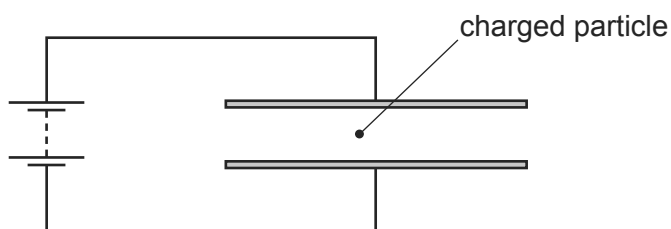

There is a force  $F$  on the particle due to the electric field.

The separation of the plates is doubled.

What will be the new force on the particle?

- A**  $\frac{F}{4}$       **B**  $\frac{F}{2}$       **C**  $F$       **D**  $2F$

- 89 The diagram shows two parallel plates.

9702/13/O/N/12/Q30

The plates are charged so that there is an electric field between them. P, Q and R are points which are  $\frac{1}{4}$ ,  $\frac{1}{2}$  and  $\frac{3}{4}$  of the distance from the top plate to the bottom plate.

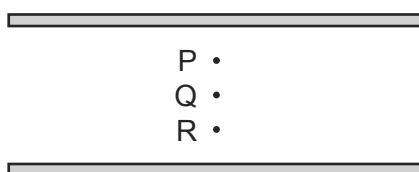

What is the electric field strength at point P?

- A** the same as that at point Q  
**B** twice that at point R  
**C** half that at point R  
**D** one third that at point Q
- 90 A positive charge of  $2.6 \times 10^{-8} \text{ C}$  is in an electric field of constant field strength  $300\,000 \text{ V m}^{-1}$ .

How much work must be done on the charge in order to move it a distance of 4.0 mm in the opposite direction to the direction of the field?

9702/13/O/N/12/Q31

- A**  $3.1 \times 10^{-5} \text{ J}$   
**B**  $2.0 \times 10^{-3} \text{ J}$   
**C**  $3.1 \times 10^{-2} \text{ J}$   
**D** 2.0 J



- 91 A beam of electrons is directed into an electric field and is deflected by it.

9702/11/M/J/13/Q30

Diagram 1 represents an electric field in the plane of the paper.

Diagram 2 represents an electric field directed perpendicular to the plane of the paper.

The lines **A**, **B**, **C** and **D** represent possible paths of the electron beam. All paths are in the plane of the paper.

Which line best represents the path of the electrons inside the field?

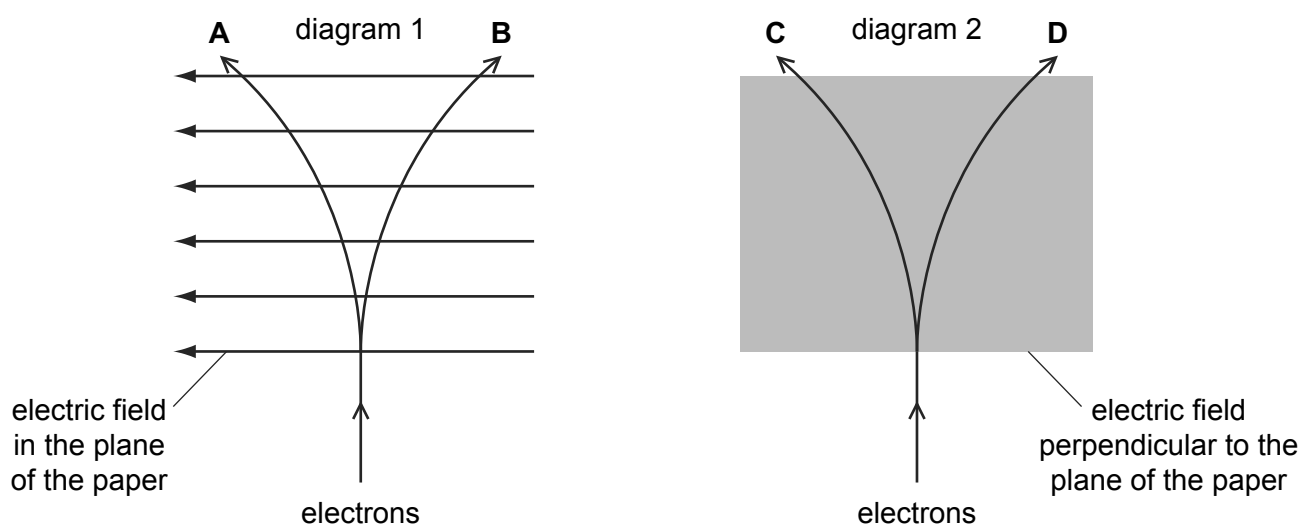

- 92 Two oppositely-charged parallel plates are arranged as shown.

9702/11/M/J/13/Q31

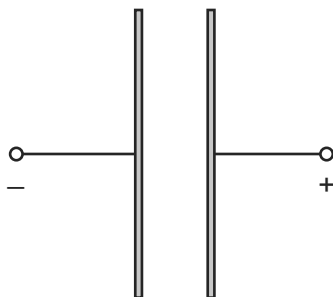

An electron is released from rest from the surface of the negatively-charged plate.

The electron travels from the negatively-charged plate towards the positively-charged plate.

Which graph shows how the force  $F$  on the electron varies with its distance  $x$  from the negative plate?

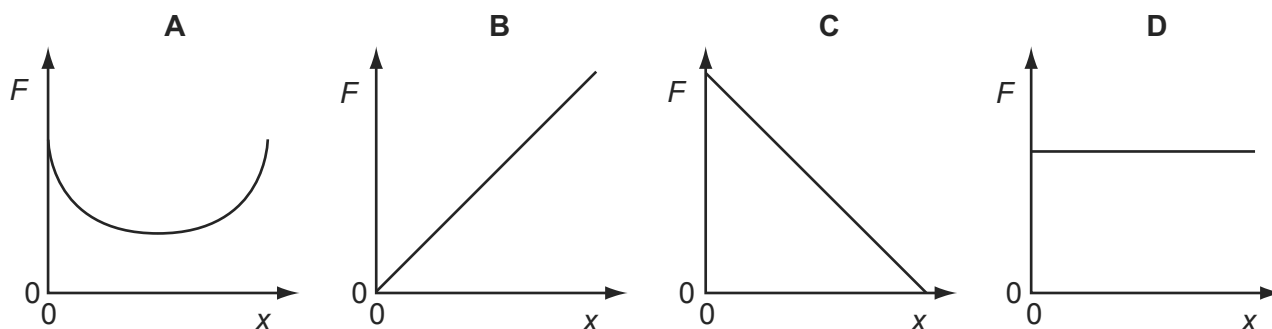

- 93 Two conducting layers of a liquid crystal display of a calculator are  $8\mu\text{m}$  apart. A  $1.5\text{V}$  cell is connected across the conducting layers when the calculator is switched on. 9702/12/M/J/13/Q30

What is the electric field strength between the layers?

- A**  $1.2 \times 10^{-5}\text{Vm}^{-1}$   
**B**  $0.19\text{Vm}^{-1}$   
**C**  $12\text{Vm}^{-1}$   
**D**  $1.9 \times 10^5\text{Vm}^{-1}$

- 94 A positively-charged particle is projected into a uniform electric field. 9702/12/M/J/13/Q31

Which diagram represents the path of the particle in the electric field?

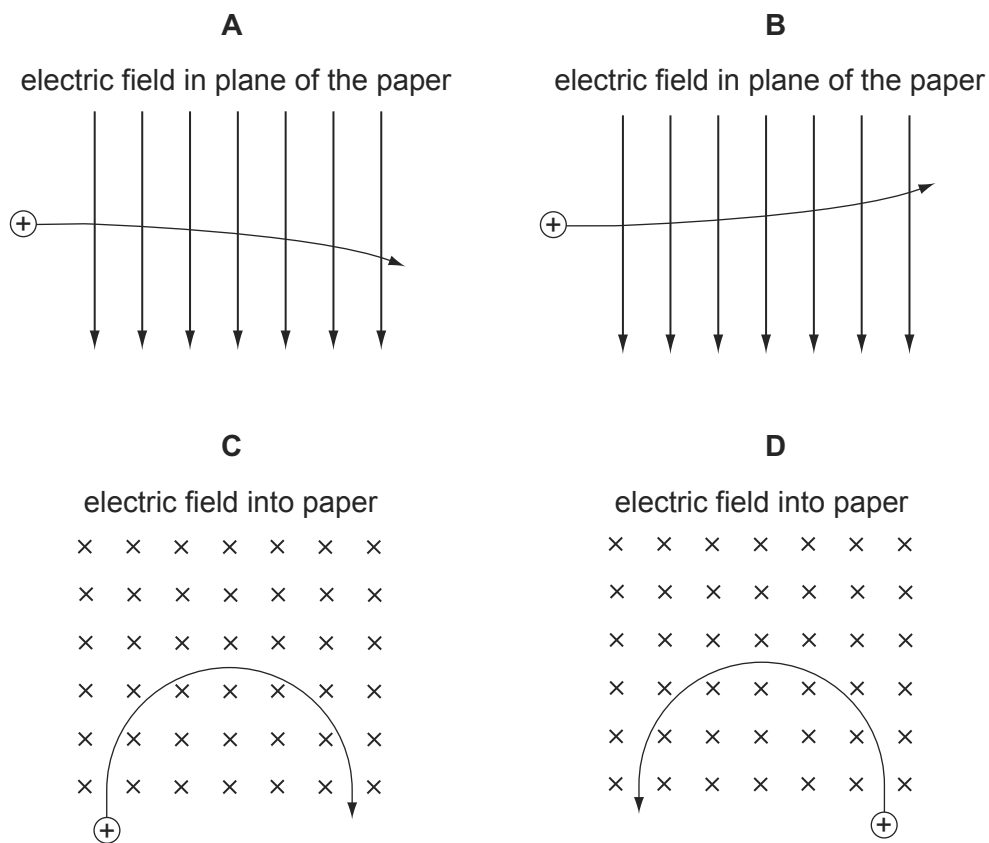

- 95 Two metal plates are held horizontal and parallel, 5.0 cm apart. The plates are at potentials of +100 V and +20 V.

9702/13/M/J/13/Q29

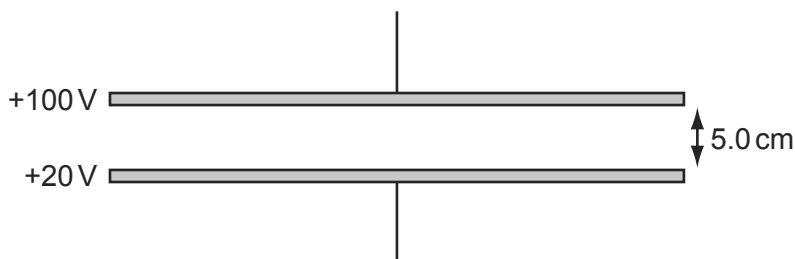

What is the force experienced by an electron in the electric field between the plates?

- A**  $2.6 \times 10^{-18}$  N  
**B**  $3.8 \times 10^{-18}$  N  
**C**  $2.6 \times 10^{-16}$  N  
**D**  $3.8 \times 10^{-16}$  N
- 96 The diagram shows the path of a charged particle through a uniform electric field, having vertical field lines.

9702/13/M/J/13/Q30

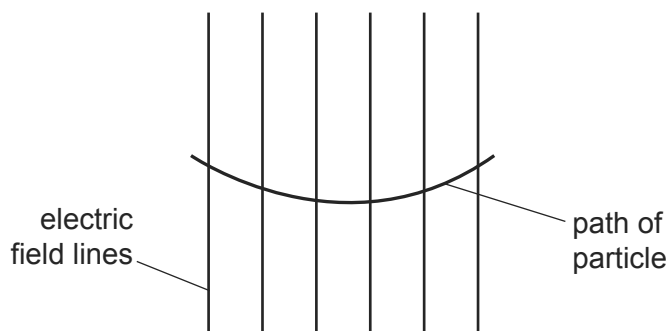

What could give a path of this shape?

- A** a positive charge travelling left to right in a field directed downwards  
**B** a positive charge travelling right to left in a field directed downwards  
**C** a negative charge travelling right to left in a field directed upwards  
**D** a negative charge travelling left to right in a field directed downwards
- 97 A small charge  $q$  is placed in the electric field of a large charge  $Q$ .

9702/13/O/N/13/Q31

Both charges experience a force  $F$ .

What is the electric field strength of the charge  $Q$  at the position of the charge  $q$ ?

- A**  $\frac{F}{Qq}$       **B**  $\frac{F}{Q}$       **C**  $FqQ$       **D**  $\frac{F}{q}$

98 Two charged parallel metal plates produce an electric field.

9702/13/O/N/13/Q30

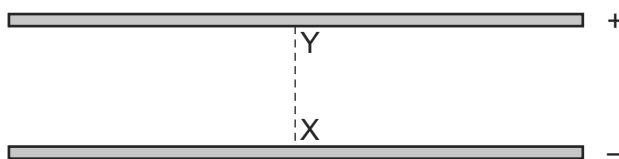

A charged particle moves from X to Y.

Which graph shows the variation of the force on the particle with distance from X along the line XY?

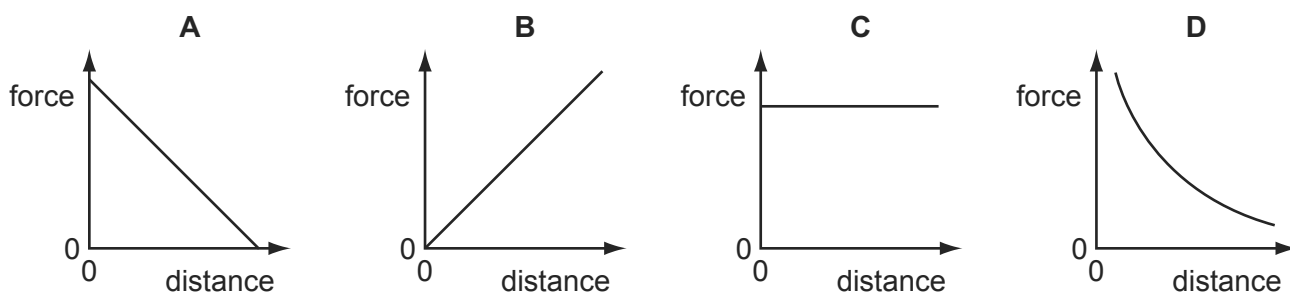

99 Two vertical conducting plates X and Y are positioned so that they are separated by a distance of 6.0 mm in air. A 60 V d.c. supply is connected as shown.

9702/11/O/N/13/Q31

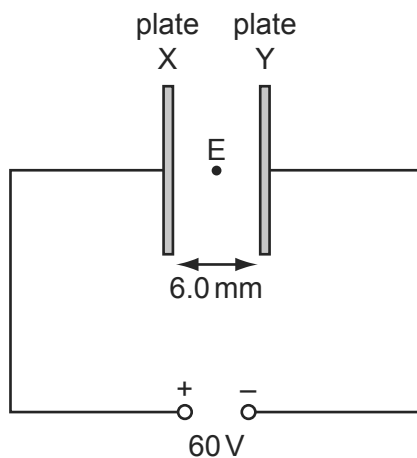

What is the electric field strength at E, a point midway between the plates?

- A  $1.0 \times 10^4 \text{ V m}^{-1}$  towards X
- B  $1.0 \times 10^4 \text{ V m}^{-1}$  towards Y
- C  $2.0 \times 10^4 \text{ V m}^{-1}$  towards X
- D  $2.0 \times 10^4 \text{ V m}^{-1}$  towards Y

- 100 A horizontal beam of electrons is passed between two horizontal parallel plates, 2.0 cm apart, as shown.

9702/11/M/J/14/Q28

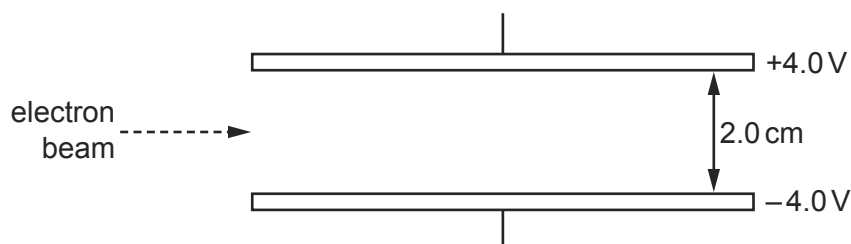

The upper plate has an electrical potential of +4.0V, and the lower plate has an electrical potential of -4.0V.

What is the force on each electron when between the plates?

- A**  $3.2 \times 10^{-17}$  N downwards  
**B**  $3.2 \times 10^{-19}$  N upwards  
**C**  $6.4 \times 10^{-19}$  N downwards  
**D**  $6.4 \times 10^{-17}$  N upwards
- 101 Two oppositely-charged horizontal metal plates are placed in a vacuum. A positively-charged particle starts from rest and moves from one plate to the other plate, as shown.

9702/12/M/J/14/Q29

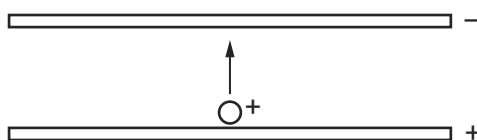

Which graph shows how the kinetic energy  $E_k$  of the particle varies with the distance  $x$  moved from the positive plate?

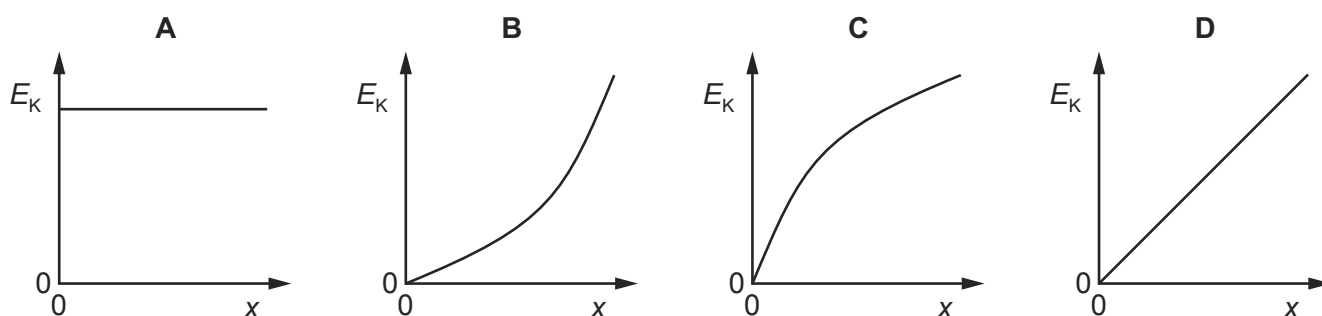

- 102 The diagram shows two points P and Q which lie  $90^\circ$  apart on a circle of radius  $r$ . 9702/11/M/J/14/Q29

A positive point charge at the centre of the circle creates an electric field of magnitude  $E$  at both P and Q.

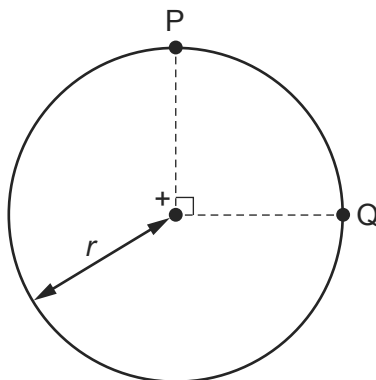

Which expression gives the work done in moving a unit positive charge from P to Q?

- A 0                      B  $E \times r$                       C  $E \times \left(\frac{\pi r}{2}\right)$                       D  $E \times (\pi r)$
- 103 Two parallel plates X and Y are separated by a distance  $d$  in a vacuum. There is a potential difference between the plates so that a uniform electric field is produced. 9702/13/M/J/14/Q32

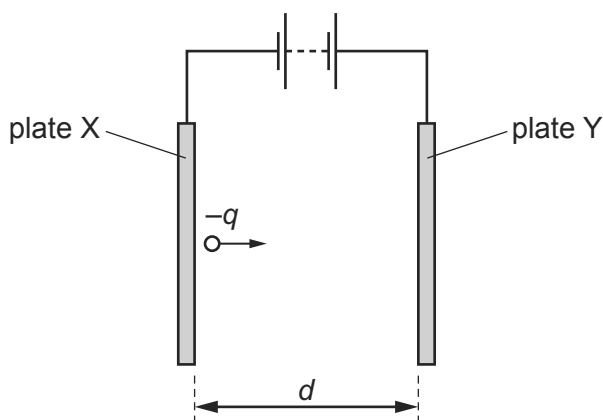

A charge  $-q$  moves from rest from the surface of plate X and travels towards plate Y.

When the charge reaches plate Y it has kinetic energy  $K$ .

Which expression gives the electric field strength between the plates?

- A  $\frac{q}{Kd}$                       B  $\frac{qd}{K}$                       C  $\frac{K}{qd}$                       D  $\frac{Kd}{q}$

- 104 Two positive charges and one negative charge, all of equal magnitude, are set at the corners of an equilateral triangle.

9702/12/M/J/14/Q28

Which diagram best represents the electric field surrounding the charges?

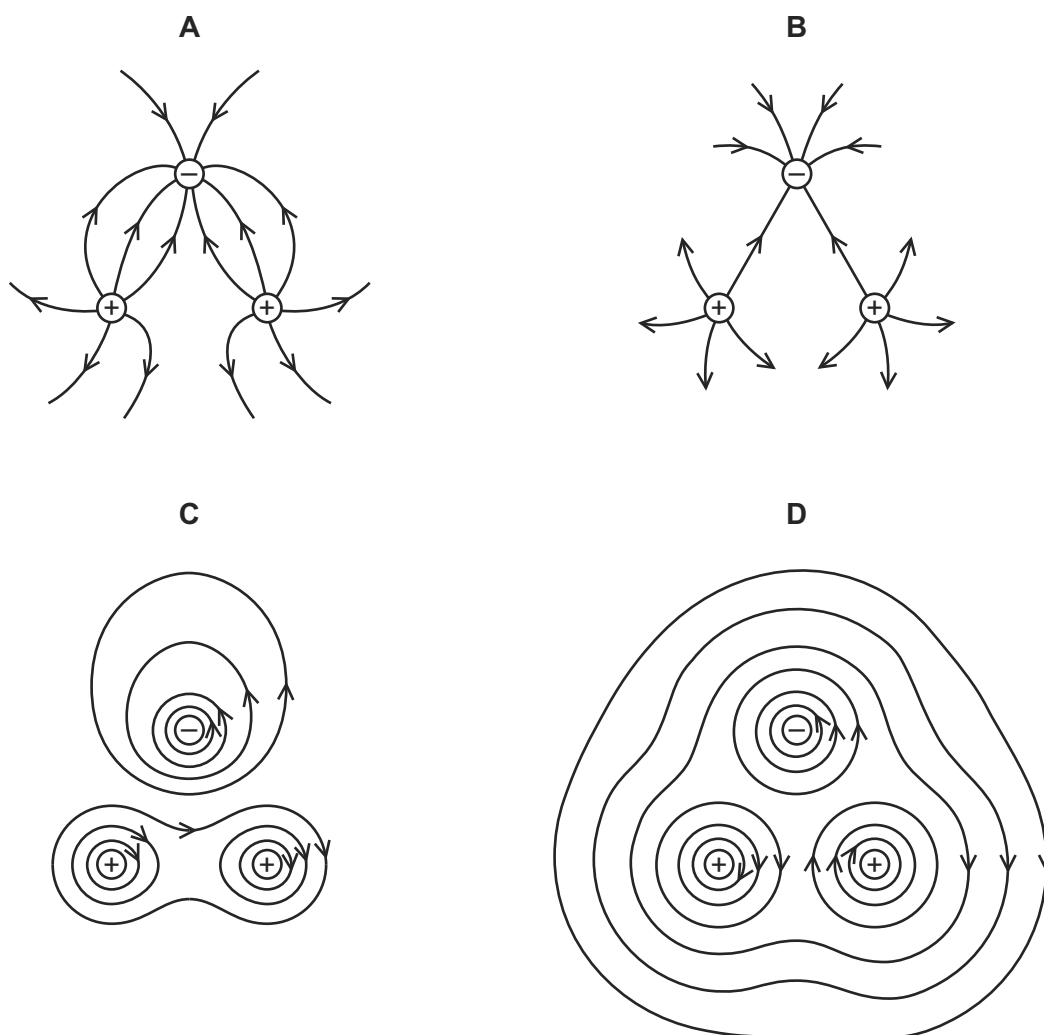

- 105 A particle is in a uniform field. The particle experiences a force in the opposite direction to the field.

9702/11/O/N/13/Q13

Which field is the particle in, and on which property of the particle is the field acting?

	field	property of particle on which the field acts
<b>A</b>	electric	charge
<b>B</b>	electric	current
<b>C</b>	gravitational	mass
<b>D</b>	gravitational	weight

- 106 Two parallel metal plates have a potential difference between them of 12V. The distance between the plates is 1.0 mm.

9702/11/O/N/13/Q32

What are the electric field strength between the plates and the work done on a charge of  $+3.9\mu\text{C}$  to move the charge from the negative plate to the positive plate?

	electric field strength/ $\text{NC}^{-1}$	work done /J
<b>A</b>	12	$4.7 \times 10^{-5}$
<b>B</b>	12	47
<b>C</b>	12 000	$4.7 \times 10^{-5}$
<b>D</b>	12 000	47

- 107 The diagram shows two parallel horizontal metal plates. There is a potential difference  $V$  between the plates.

9702/11/O/N/14/Q28

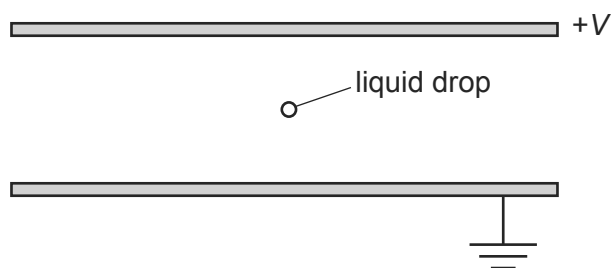

A small charged liquid drop, midway between the plates, is held in equilibrium by the combination of its weight and the electric force acting on it.

The acceleration of free fall is  $g$  and the electric field strength is  $E$ .

What is the polarity of the charge on the drop, and the ratio of charge to mass of the drop?

	polarity	$\frac{\text{charge}}{\text{mass}}$
<b>A</b>	negative	$\frac{E}{g}$
<b>B</b>	negative	$\frac{g}{E}$
<b>C</b>	positive	$\frac{E}{g}$
<b>D</b>	positive	$\frac{g}{E}$



108 The diagram shows two metal plates connected to a constant high voltage.

9702/11/O/N/14/Q29

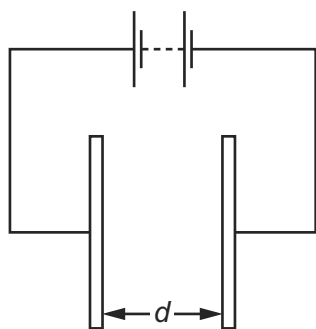

Which graph shows the variation of the electric field strength  $E$  midway between the two plates as the distance  $d$  between the two plates is increased?

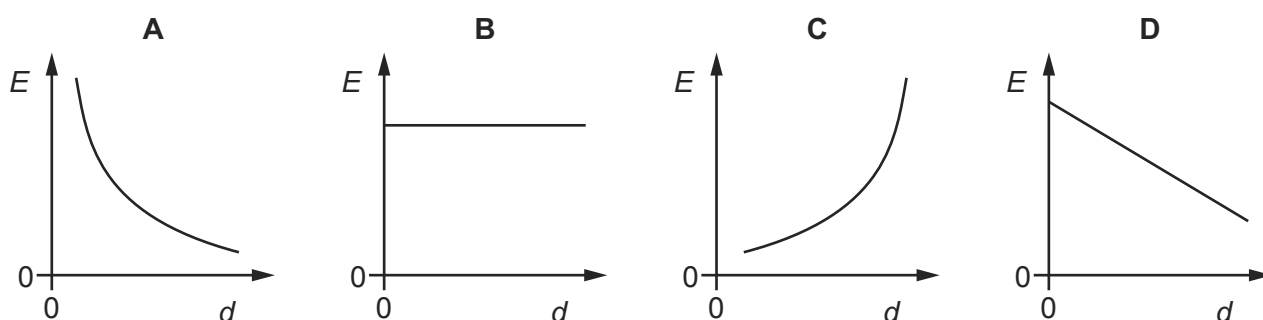

109 An electron enters a region of space where there is a uniform electric field  $E$  as shown.

9702/13/M/J/14/Q31



Initially, the electron is moving parallel to, and in the direction of, the electric field.

What is the subsequent path and change of speed of the electron?

	path of electron	speed of electron
<b>A</b>	linear	decreases
<b>B</b>	linear	increases
<b>C</b>	parabolic	decreases
<b>D</b>	parabolic	increases

110 Regions of unbalanced charge are produced inside a cloud as shown.

9702/13/O/N/14/Q31

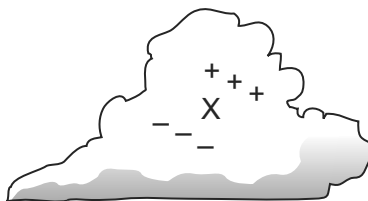

For the region X, which diagram correctly represents the direction of the electric field and the initial direction in which electrons would move?

	A	B	C	D
electric field				
direction of movement of electrons				

111 The path of an electron with initial speed  $v$  in the uniform electric field between two parallel plates is shown.

9702/13/O/N/14/Q32

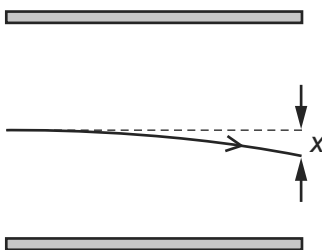

The vertical deflection  $x$  is measured at the right-hand edge of the plates.

The distance between the plates is halved. The potential difference between the plates remains the same.

What will be the new deflection of the electron with the same initial speed  $v$ ?

- A  $x$                       B  $\sqrt{2}x$                       C  $2x$                       D  $4x$

112 Which unit is **not** used in either the definition of the coulomb or the definition of the volt?

9702/12/M/J/15/Q31

- A ampere  
B joule  
C ohm  
D second

- 113 A molecule behaves as an electric dipole consisting of two equal point charges, of opposite sign, separated by a fixed distance. The molecule moves with constant horizontal velocity as it enters a vertical uniform electric field, as shown.

9702/13/M/J/15/Q30

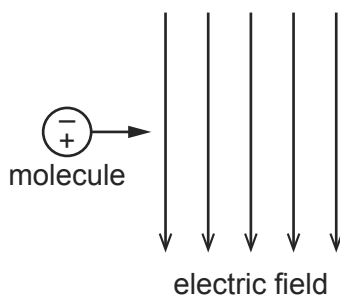

The positive and negative charges of the molecule enter the field at the same time.

Which row describes the velocity of the molecule in the field?

	horizontal component of velocity	vertical component of velocity
<b>A</b>	constant	increases
<b>B</b>	constant	zero
<b>C</b>	increases	increases
<b>D</b>	increases	zero

- 114 Which diagram best represents the electric field between two point charges of equal magnitude and opposite sign?

9702/13/M/J/15/Q31

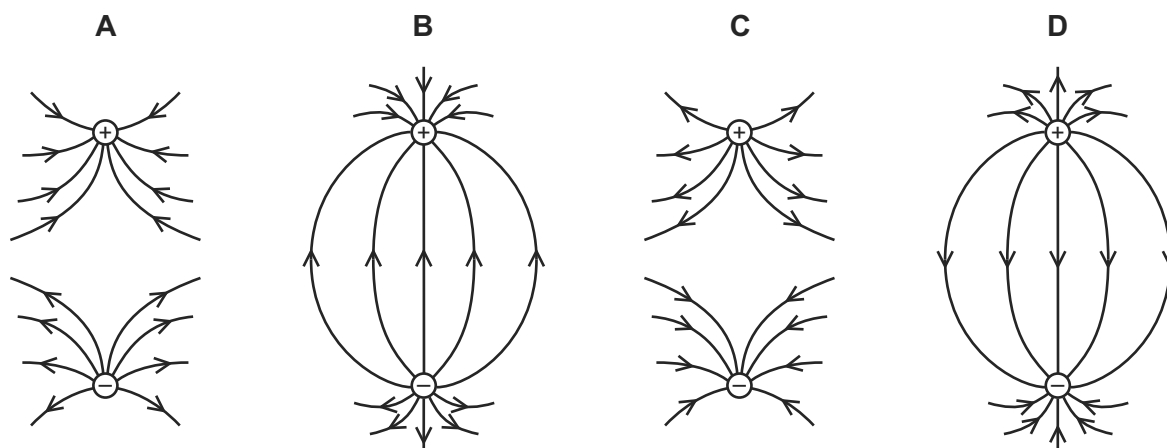

- 115 Two parallel metal plates, a distance of 2 mm apart, have a potential difference of 1000 V across them.

9702/11/M/J/15/Q31

What is the electric field strength between the plates?

- A**  $500 \text{ V m}^{-1}$     **B**  $50\,000 \text{ V m}^{-1}$     **C**  $50\,000 \text{ NC}^{-1}$     **D**  $500\,000 \text{ NC}^{-1}$

116 A positive charge and a negative charge of equal magnitude are placed a short distance apart.

Which diagram best represents the associated electric field?

9702/12/M/J/15/Q29

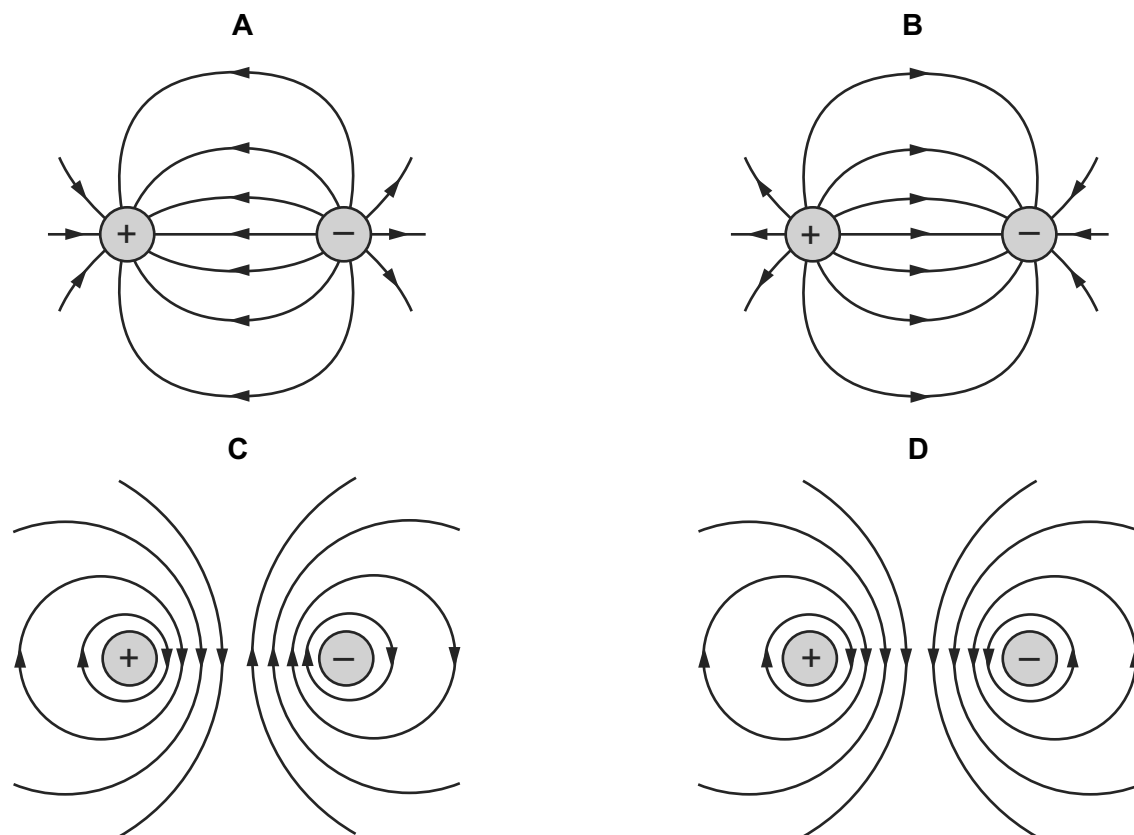

117 A charged oil drop of mass  $m$ , with  $n$  excess electrons, is held stationary in the uniform electric field between two horizontal plates separated by a distance  $d$ .

9702/12/M/J/15/Q30

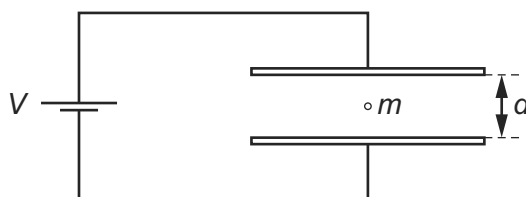

The voltage between the plates is  $V$ , the elementary charge is  $e$  and the acceleration of free fall is  $g$ .

What is the value of  $n$ ?

A  $\frac{eV}{mgd}$

B  $\frac{mgd}{eV}$

C  $\frac{meV}{gd}$

D  $\frac{gd}{meV}$

- 118 An oil droplet has charge  $-q$  and is situated between two horizontal metal plates as shown in the diagram.

9702/11/M/J/15/Q32

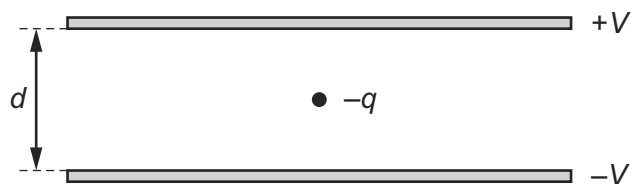

The separation of the plates is  $d$ . The droplet is observed to be stationary when the upper plate is at potential  $+V$  and the lower plate is at potential  $-V$ .

For this to occur, what is the weight of the droplet?

- A**  $\frac{Vq}{d}$       **B**  $\frac{2Vq}{d}$       **C**  $\frac{Vd}{q}$       **D**  $\frac{2Vd}{q}$

- 1 The graphs show the variation with potential difference  $V$  of the current  $I$  for three circuit elements.

9702/1/M/J/02/Q30

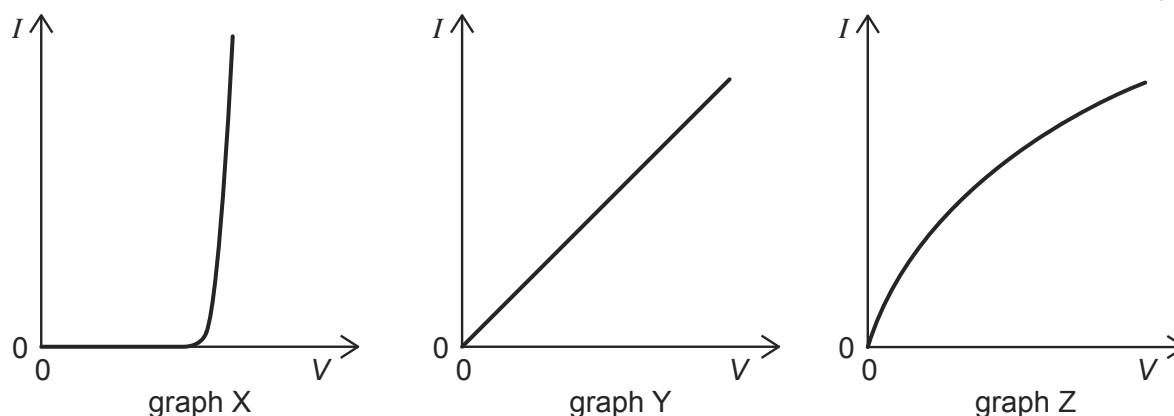

The three circuit elements are a metal wire at constant temperature, a semiconductor diode and a filament lamp.

Which row of the table correctly identifies these graphs?

	metal wire at constant temperature	semiconductor diode	filament lamp
<b>A</b>	X	Z	Y
<b>B</b>	Y	X	Z
<b>C</b>	Y	Z	X
<b>D</b>	Z	X	Y

- 2 In the circuit below, the battery converts an amount  $E$  of chemical energy to electrical energy when charge  $Q$  passes through the resistor in time  $t$ .

9702/1/M/J/02/Q31

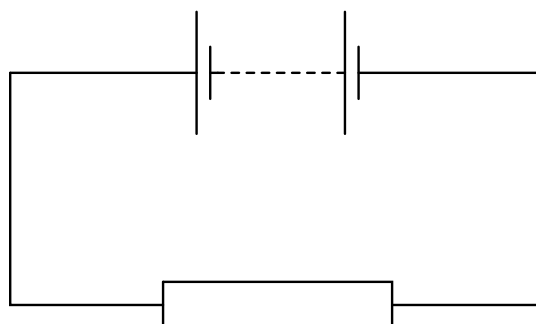

Which expressions give the e.m.f. of the battery and the current in the resistor?

	e.m.f.	current
<b>A</b>	$EQ$	$Q/t$
<b>B</b>	$EQ$	$Qt$
<b>C</b>	$E/Q$	$Q/t$
<b>D</b>	$E/Q$	$Qt$

- 3 The diagrams show connected wires which carry currents  $I_1$ ,  $I_2$ ,  $I_3$  and  $I_4$ .

The currents are related by the equation  $I_1 + I_2 = I_3 + I_4$ .

To which diagram does this equation apply?

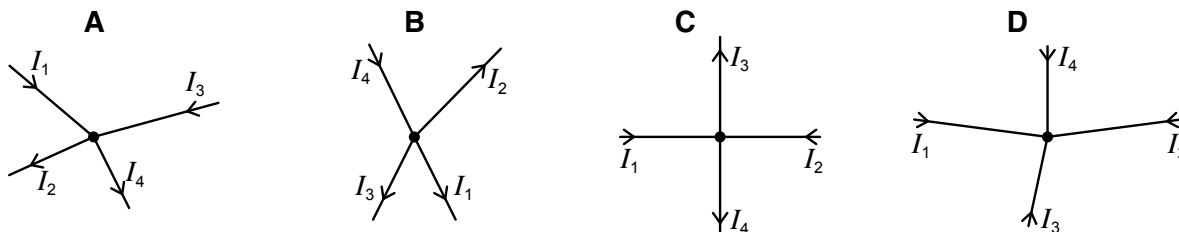

- 4 A potential divider is used to give outputs of 2 V and 3 V from a 5 V source, as shown. 9702/1/M/J/02/Q35

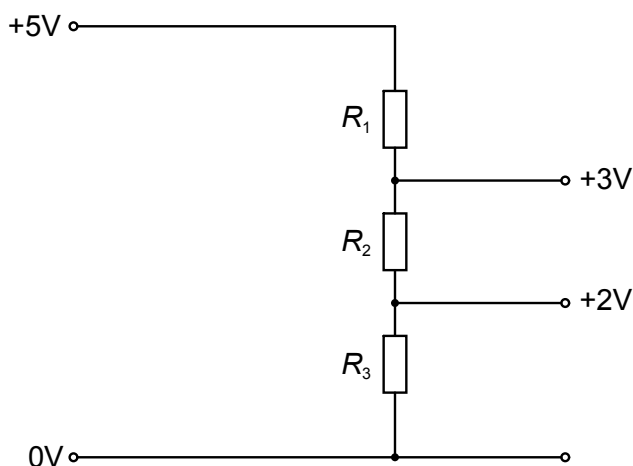

What are possible values for the resistances  $R_1$ ,  $R_2$  and  $R_3$ ?

	$R_1/\text{k}\Omega$	$R_2/\text{k}\Omega$	$R_3/\text{k}\Omega$
<b>A</b>	2	1	5
<b>B</b>	3	2	2
<b>C</b>	4	2	4
<b>D</b>	4	6	10

- 5 Which equation is used to define resistance?

- A** power = (current)<sup>2</sup> × resistance  
**B** resistivity = resistance × area ÷ length  
**C** potential difference = current × resistance  
**D** energy = (current)<sup>2</sup> × resistance × time

- 6 When four identical lamps P, Q, R and S are connected as shown in diagram 1, they have normal brightness.

9702/1/M/J/02/Q34

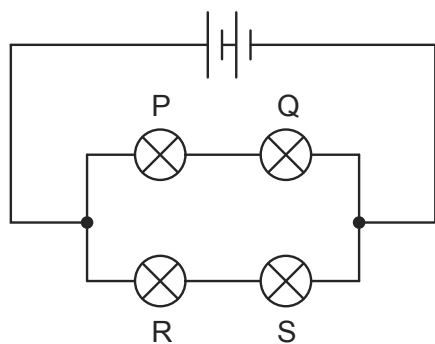

diagram 1

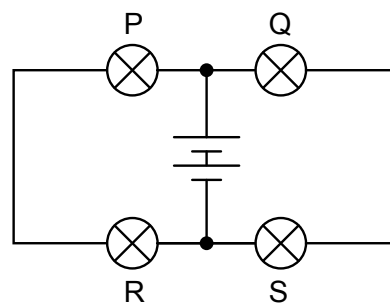

diagram 2

When the four lamps are connected as shown in diagram 2, which statement is correct?

- A The lamps do not light.  
 B The lamps are less bright than normal.  
 C The lamps have normal brightness.  
 D The lamps are brighter than normal.
- 7 The filament of a 240 V, 100 W electric lamp heats up from room temperature to its operating temperature. As it heats up, its resistance increases by a factor of 16.

9702/1/M/J/02/Q32

What is the resistance of this lamp at room temperature?

- A 36  $\Omega$     B 580  $\Omega$     C 1.5 k $\Omega$     D 9.2 k $\Omega$
- 8 At a circuit junction, a current  $I$  divides into currents  $I_1$ ,  $I_2$  and  $I_3$ .

9702/1/O/N/02/Q33

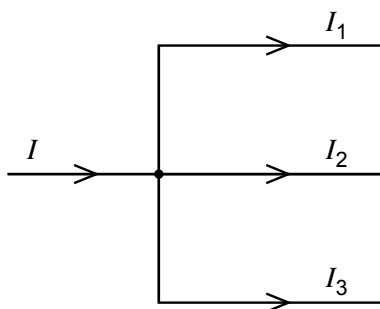

These currents are related by the equation

$$I = I_1 + I_2 + I_3.$$

Which law does this statement illustrate and on what principle is the law based?

- A Kirchhoff's first law based on conservation of charge  
 B Kirchhoff's first law based on conservation of energy  
 C Kirchhoff's second law based on conservation of charge  
 D Kirchhoff's second law based on conservation of energy



- 9 The graph shows how the current through a lamp filament varies with the potential difference across it.

9702/1/O/N/02/Q31

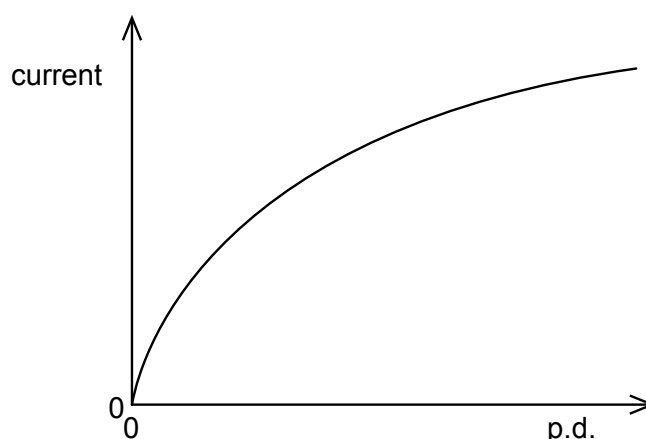

Which statement explains the shape of this graph?

- A As the filament temperature rises, electrons can pass more easily through the filament.  
 B It takes time for the filament to reach its working temperature.  
 C The power output of the filament is proportional to the square of the current through it.  
 D The resistance of the filament increases with a rise in temperature.
- 10 The combined resistance  $R_T$  of two resistors of resistances  $R_1$  and  $R_2$  connected in parallel is given by the formula

9702/1/O/N/02/Q34

$$\frac{1}{R_T} = \frac{1}{R_1} + \frac{1}{R_2}$$

Which statement is used in the derivation of this formula?

- A The currents through the two resistors are equal.  
 B The potential difference across each resistor is the same.  
 C The supply current is split between the two resistors in the same ratio as the ratio of their resistances.  
 D The total power dissipated is the sum of the powers dissipated in the two resistors separately.
- 11 The sum of the electrical currents into a point in a circuit is equal to the sum of the currents out of the point.

9702/01/M/J/03/Q31

Which of the following is correct?

- A This is Kirchhoff's first law, which results from the conservation of charge.  
 B This is Kirchhoff's first law, which results from the conservation of energy.  
 C This is Kirchhoff's second law, which results from the conservation of charge.  
 D This is Kirchhoff's second law, which results from the conservation of energy.

- 12 The variation with potential difference  $V$  of the current  $I$  in a semiconductor diode is shown below.

9702/1/O/N/02/Q32

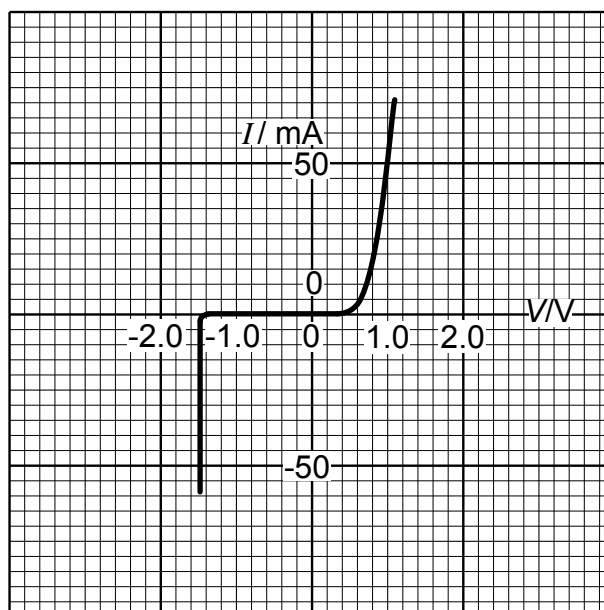

What is the resistance of the diode for applied potential differences of  $+1.0\text{ V}$  and  $-1.0\text{ V}$ ?

	resistance	
	at $+1.0\text{ V}$	at $-1.0\text{ V}$
<b>A</b>	$20\ \Omega$	infinite
<b>B</b>	$20\ \Omega$	zero
<b>C</b>	$0.05\ \Omega$	infinite
<b>D</b>	$0.05\ \Omega$	zero

- 13 Six resistors, each of resistance  $5\ \Omega$ , are connected to a  $2\text{ V}$  cell of negligible internal resistance.

9702/1/O/N/02/Q36

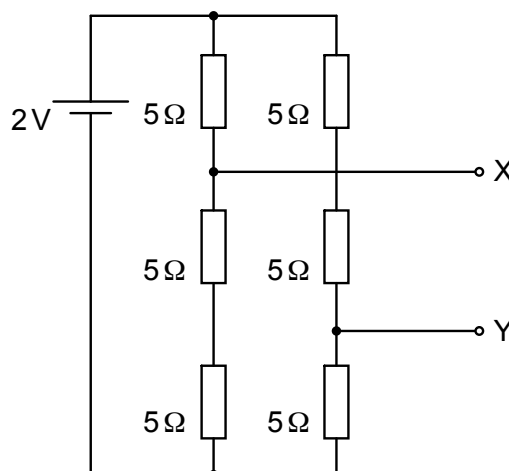

What is the potential difference between terminals X and Y?

- A**  $\frac{2}{3}\text{ V}$       **B**  $\frac{8}{9}\text{ V}$       **C**  $\frac{4}{3}\text{ V}$       **D**  $2\text{ V}$

- 14 In the potentiometer circuit below, the moveable contact is placed at N on the bare wire XY, such that the galvanometer shows zero deflection.

9702/1/O/N/02/Q35

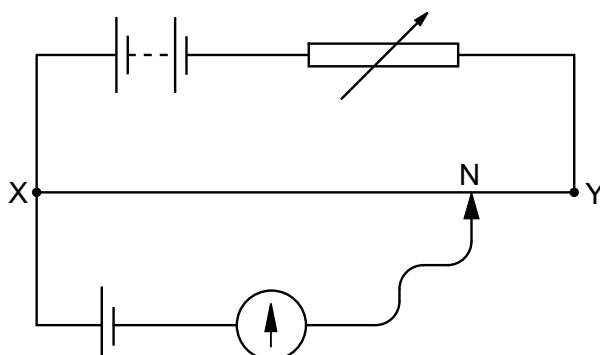

The resistance of the variable resistor is now increased.

What is the effect of this increase on the potential difference across the wire XY and on the position of the moveable contact for zero deflection?

	potential difference across XY	position of moveable contact
<b>A</b>	increases	nearer to X
<b>B</b>	increases	nearer to Y
<b>C</b>	decreases	nearer to X
<b>D</b>	decreases	nearer to Y

- 15 The current in a component is reduced uniformly from 100 mA to 20 mA over a period of 8.0 s .

9702/01/M/J/03/Q30

What is the charge that flows during this time?

- A** 160 mC    **B** 320 mC    **C** 480 mC    **D** 640 mC

- 16 The e.m.f. of the cell in the following circuit is 9.0 V . The reading on the high-resistance voltmeter is 7.5 V .

9702/01/M/J/08/Q32

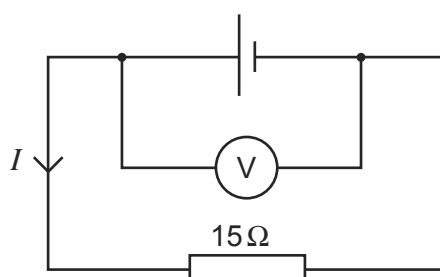

What is the current  $I$ ?

- A** 0.1 A    **B** 0.5 A    **C** 0.6 A    **D** 2.0 A

- 17 The diagram shows an arrangement of four resistors.

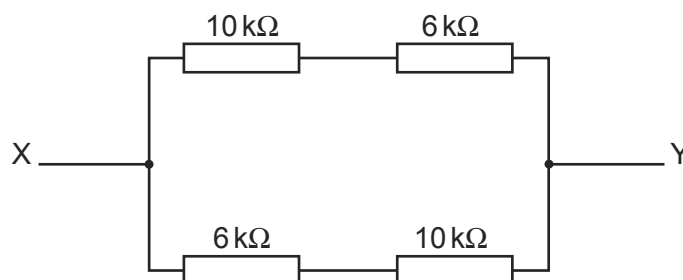

What is the resistance between X and Y?

- A 4 kΩ      B 8 kΩ      C 16 kΩ      D 32 kΩ
- 18 The diagram shows a potential divider connected to a 9.0 V supply of negligible internal resistance.

9702/01/M/J/03/Q34

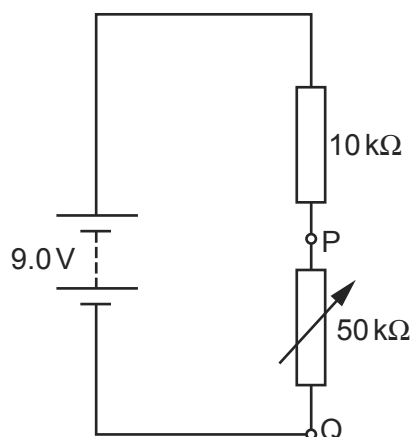

What range of voltages can be obtained between P and Q?

- A zero to 1.5 V  
 B zero to 7.5 V  
 C 1.5 V to 7.5 V  
 D 1.5 V to 9.0 V
- 19 A wire carries a current of 2.0 amperes for 1.0 hour.

9702/01/O/N/03/Q30

How many electrons pass a point in the wire in this time?

- A  $1.2 \times 10^{-15}$   
 B  $7.2 \times 10^3$   
 C  $1.3 \times 10^{19}$   
 D  $4.5 \times 10^{22}$

- 20 The diagram shows a circuit in which the battery has negligible internal resistance.

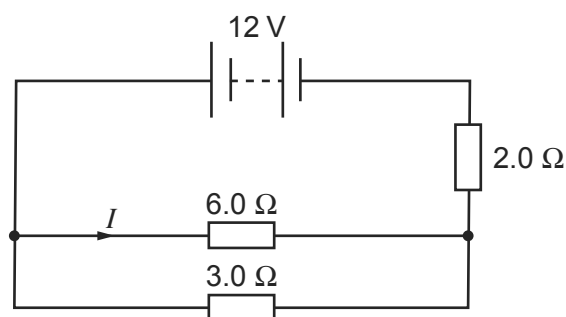

What is the value of the current  $I$ ?

- A 1.0 A      B 1.6 A      C 2.0 A      D 3.0 A
- 21 Two wires made of the same material and of the same length are connected in parallel to the same voltage supply. Wire P has a diameter of 2 mm. Wire Q has a diameter of 1 mm.

9702/01/M/J/04/Q31

What is the ratio  $\frac{\text{current in P}}{\text{current in Q}}$  ?

- A  $\frac{1}{4}$       B  $\frac{1}{2}$       C 2      D 4
- 22 The diagram shows currents  $I_1$ ,  $I_2$ ,  $I_3$ ,  $I_4$  and  $I_5$  in different branches of a circuit.

9702/01/O/N/03/Q32

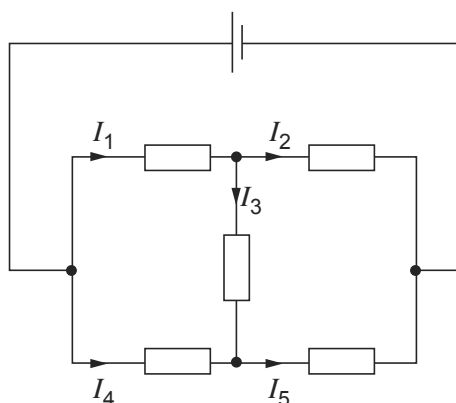

Which one of the following is correct?

- A  $I_1 = I_2 + I_3$   
 B  $I_2 = I_1 + I_3$   
 C  $I_3 = I_4 + I_5$   
 D  $I_4 = I_5 + I_3$

23 Which diagram shows a potential divider circuit that can vary the voltage across the lamp?

9702/01/O/N/03/Q33

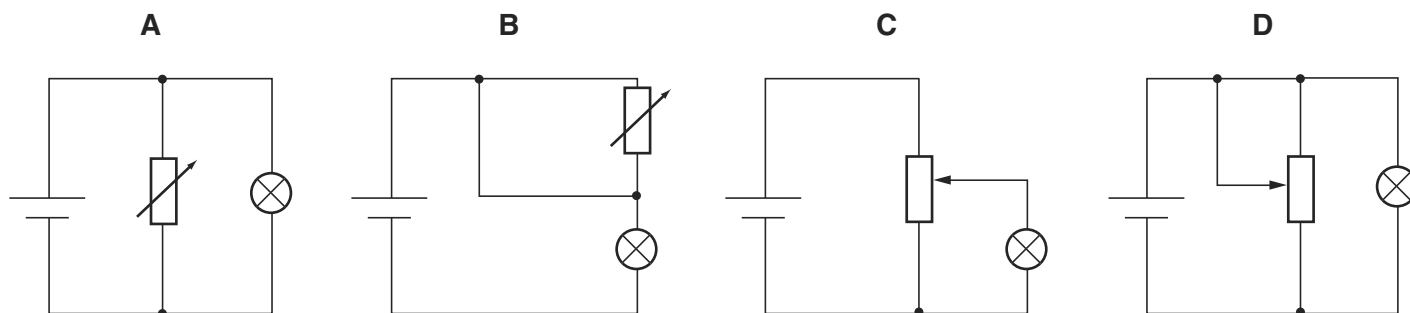

24 The diagram shows two circuits. In these circuits, only the internal resistances differ.

9702/01/O/N/03/Q34

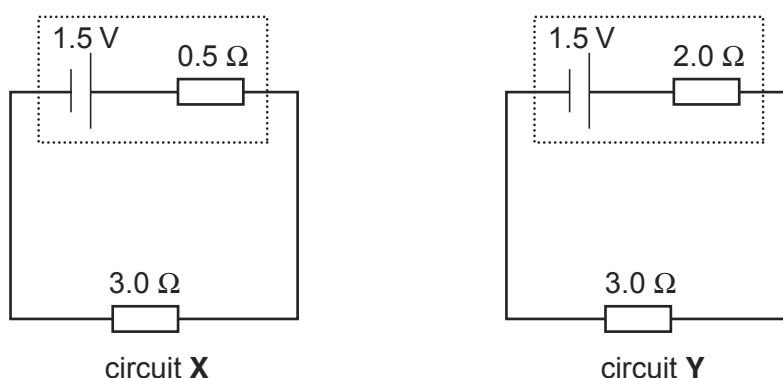

Which line in the table is correct?

	potential difference across $3.0\ \Omega$ resistor	power dissipated in $3.0\ \Omega$ resistor
<b>A</b>	greater in X than in Y	less in X than in Y
<b>B</b>	greater in X than in Y	greater in X than in Y
<b>C</b>	less in X than in Y	less in X than in Y
<b>D</b>	less in X than in Y	greater in X than in Y

25 What is an equivalent unit to 1 volt?

9702/01/M/J/04/Q32

- A**  $1\text{ J A}^{-1}$       **B**  $1\text{ J C}^{-1}$       **C**  $1\text{ W C}^{-1}$       **D**  $1\text{ W s}^{-1}$

26 The potential difference between point X and point Y is 20V. The time taken for charge carriers to move from X to Y is 15s, and, in this time, the energy of the charge carriers changes by 12J.

9702/01/M/J/04/Q34

What is the current between X and Y?

- A** 0.040A      **B** 0.11A      **C** 9.0A      **D** 25A

- 27 The terminal voltage of a battery is observed to fall when the battery supplies a current to an external resistor. 9702/01/M/J/04/Q33

What quantities are needed to calculate the fall in voltage?

- A the battery's e.m.f. and its internal resistance  
 B the battery's e.m.f. and the current  
 C the current and the battery's internal resistance  
 D the current and the external resistance
- 28 The diagram shows a battery, a fixed resistor, an ammeter and a variable resistor connected in series. 9702/01/M/J/04/Q35

A voltmeter is connected across the fixed resistor.

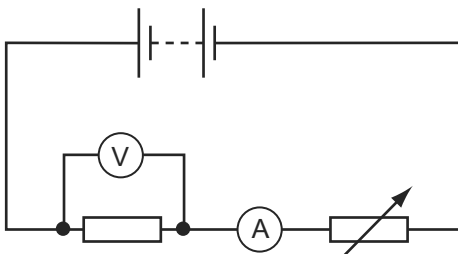

The value of the variable resistor is reduced.

Which correctly describes the changes in the readings of the ammeter and of the voltmeter?

	ammeter	voltmeter
<b>A</b>	decrease	decrease
<b>B</b>	decrease	increase
<b>C</b>	increase	decrease
<b>D</b>	increase	increase

- 29 Kirchhoff's two laws for electric circuits can be derived by using conservation laws. 9702/01/M/J/04/Q36

On which conservation laws do Kirchhoff's laws depend?

	Kirchhoff's first law	Kirchhoff's second law
<b>A</b>	charge	current
<b>B</b>	charge	energy
<b>C</b>	current	mass
<b>D</b>	energy	current

- 30 The diagram shows a parallel combination of three resistors. The total resistance of the combination is  $3\Omega$ .

9702/01/M/J/04/Q37

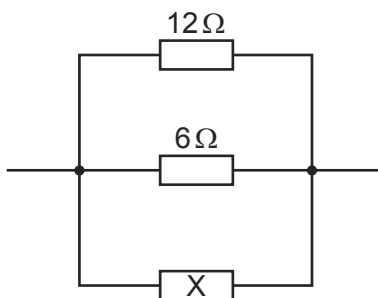

What is the resistance of resistor X?

- A**  $2\Omega$                       **B**  $3\Omega$                       **C**  $6\Omega$                       **D**  $12\Omega$
- 31 The diagram shows four heaters and the current in each.

9702/01/O/N/04/Q32

Which heater has the greatest power dissipation?

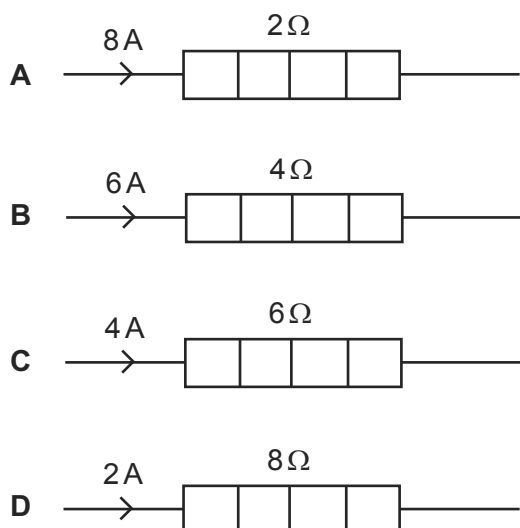

- 32 The diagram shows a junction in a circuit where three wires P, Q and R meet. The currents in P and Q are 1 A and 3 A respectively, in the directions shown.

9702/01/O/N/04/Q35

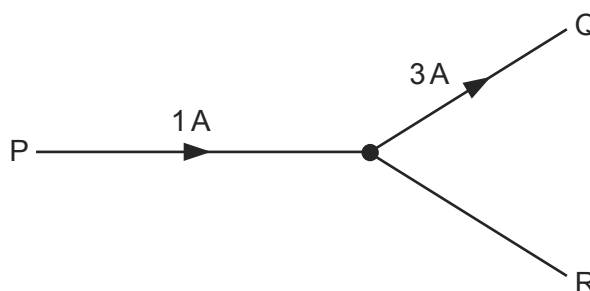

How many coulombs of charge pass a given point in wire R in 5 seconds?

- A** 0.4                      **B** 0.8                      **C** 2                      **D** 10



- 33 The resistance of a thermistor decreases significantly as its temperature increases. 9702/01/O/N/04/Q34

The thermistor is kept in air. The air is at room temperature.

Which graph best represents the way in which the current  $I$  in the thermistor depends upon the potential difference  $V$  across it?

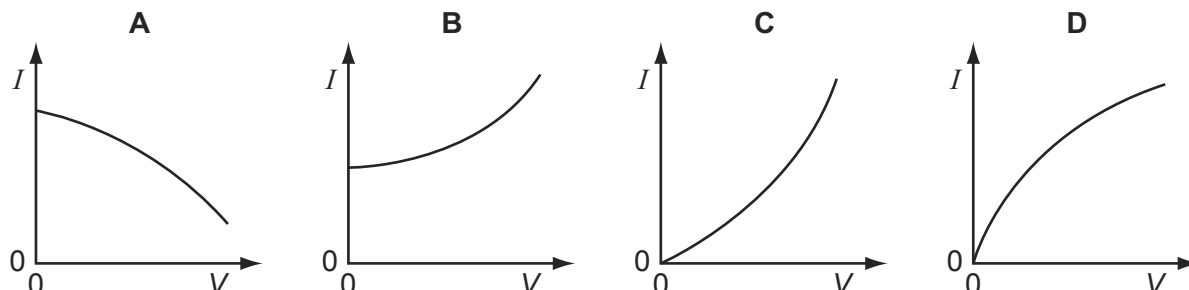

- 34 When a potential difference  $V$  is applied between the ends of a wire of diameter  $d$  and length  $l$ , the current in the wire is  $I$ .

9702/01/O/N/04/Q33

What is the current when a potential difference of  $2V$  is applied between the ends of a wire of the same material of diameter  $2d$  and the length  $2l$ ? Assume that the temperature of the wire remains constant.

- A**  $I$                       **B**  $2I$                       **C**  $4I$                       **D**  $8I$

- 35 In the circuit shown, the ammeters have negligible resistance and the voltmeters have infinite resistance. 9702/01/O/N/04/Q37

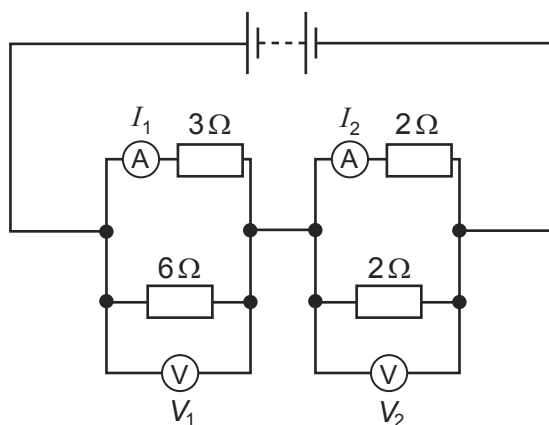

The readings on the meters are  $I_1$ ,  $I_2$ ,  $V_1$  and  $V_2$ , as labelled on the diagram.

Which is correct?

- A**  $I_1 > I_2$  and  $V_1 > V_2$   
**B**  $I_1 > I_2$  and  $V_1 < V_2$   
**C**  $I_1 < I_2$  and  $V_1 > V_2$   
**D**  $I_1 < I_2$  and  $V_1 < V_2$

- 36 The diagram shows a potential divider circuit designed to provide a variable output p.d.

9702/01/O/N/04/Q36

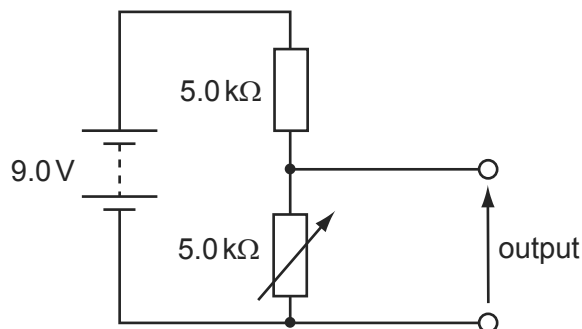

Which gives the available range of output p.d.?

	maximum output	minimum output
<b>A</b>	3.0V	0
<b>B</b>	4.5V	0
<b>C</b>	9.0V	0
<b>D</b>	9.0V	4.5V

- 37 A copper wire of cross-sectional area  $2.0 \text{ mm}^2$  carries a current of 10 A.

9702/01/M/J/05/Q32

How many electrons pass through a given cross-section of the wire in one second?

- A**  $1.0 \times 10^1$       **B**  $5.0 \times 10^6$       **C**  $6.3 \times 10^{19}$       **D**  $3.1 \times 10^{25}$
- 38 A cylindrical piece of a soft, electrically-conducting material has resistance  $R$ . It is rolled out so that its length is doubled but its volume stays constant.

9702/01/M/J/05/Q33

What is its new resistance?

- A**  $\frac{R}{2}$       **B**  $R$       **C**  $2R$       **D**  $4R$
- 39 Which electrical component is represented by the following symbol?

9702/01/M/J/05/Q35

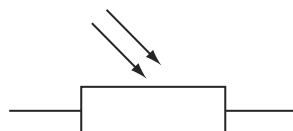

- A** a diode  
**B** a light-dependent resistor  
**C** a resistor  
**D** a thermistor

40 The  $I$ - $V$  characteristics of two electrical components P and Q are shown below.

9702/01/M/J/05/Q34

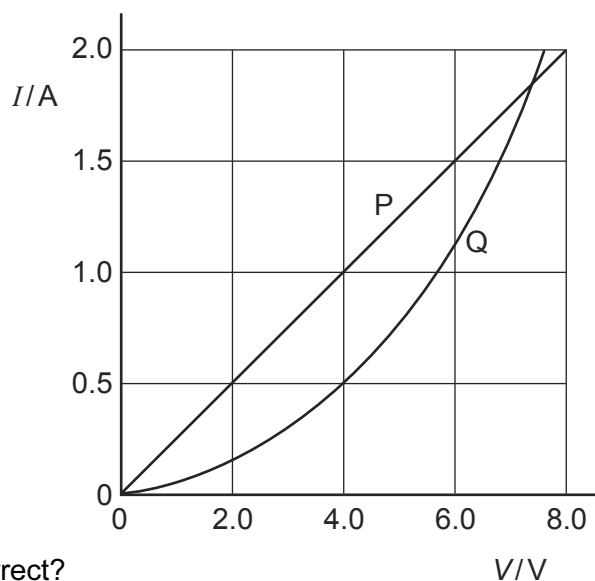

Which statement is correct?

- A** P is a resistor and Q is a filament lamp.
  - B** The resistance of Q increases as the current in it increases.
  - C** At 1.9A the resistance of Q is approximately half that of P.
  - D** At 0.5A the power dissipated in Q is double that in P.
- 41 The diagram shows a circuit with four voltmeter readings  $V$ ,  $V_1$ ,  $V_2$  and  $V_3$ .

9702/01/M/J/05/Q36

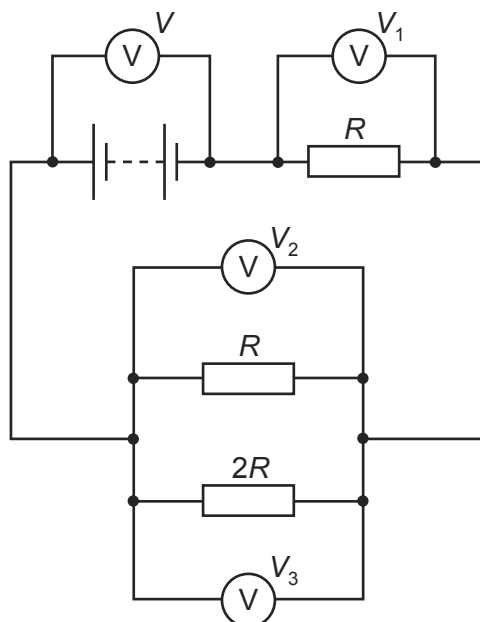

Which equation relating the voltmeter readings must be true?

- A**  $V = V_1 + V_2 + V_3$
- B**  $V + V_1 = V_2 + V_3$
- C**  $V_3 = 2(V_2)$
- D**  $V - V_1 = V_3$

- 42 In the circuit below, P is a potentiometer of total resistance  $10\ \Omega$  and Q is a fixed resistor of resistance  $10\ \Omega$ . The battery has an e.m.f. of  $4.0\ \text{V}$  and negligible internal resistance. The voltmeter has a very high resistance. The slider on the potentiometer is moved from X to Y and a graph of voltmeter reading  $V$  is plotted against slider position.

9702/01/M/J/05/Q37

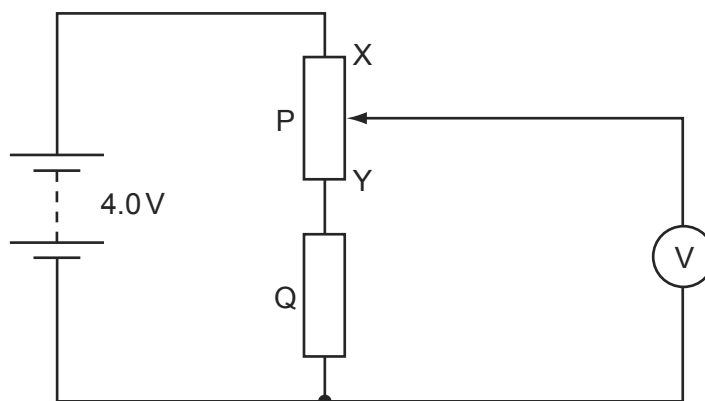

Which graph is obtained?

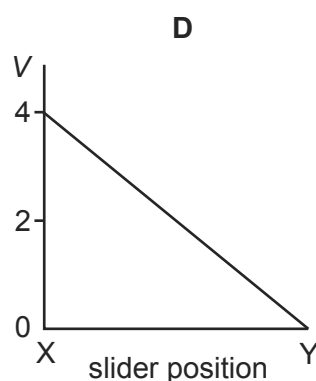
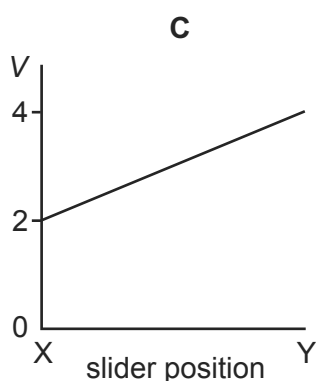
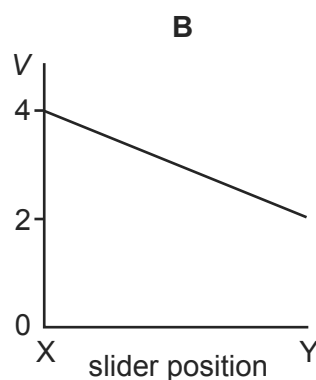
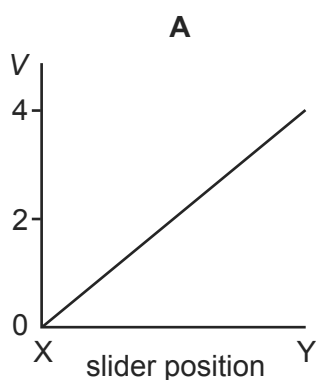

- 43 Which equation is used to define resistance?

9702/01/M/J/06/Q32

- A** energy = (current)<sup>2</sup> × resistance × time  
**B** potential difference = current × resistance  
**C** power = (current)<sup>2</sup> × resistance  
**D** resistivity = resistance × area ÷ length

- 44 The graphs show the variation with potential difference  $V$  of the current  $I$  for three circuit components.

9702/01/O/N/05/Q32

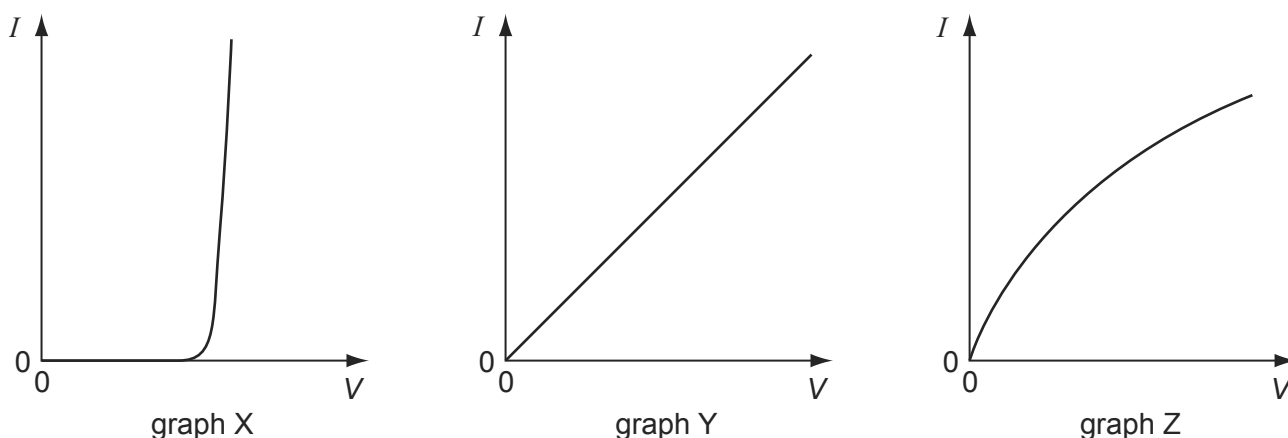

The components are a metal wire at constant temperature, a semiconductor diode and a filament lamp.

Which row of the table correctly identifies these graphs?

	metal wire at constant temperature	semiconductor diode	filament lamp
<b>A</b>	X	Z	Y
<b>B</b>	Y	X	Z
<b>C</b>	Y	Z	X
<b>D</b>	Z	X	Y

- 45 Tensile strain may be measured by the change in electrical resistance of a strain gauge. A strain gauge consists of folded fine metal wire mounted on a flexible insulating backing sheet. The strain gauge is firmly attached to the specimen, so that the strain in the metal wire is always identical to that in the specimen.

9702/01/O/N/05/Q33

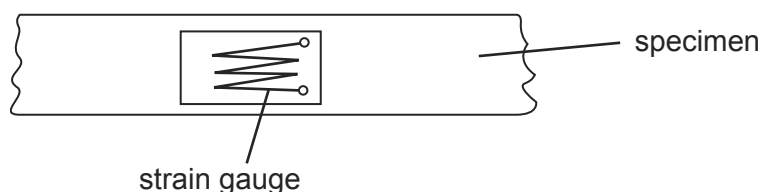

When the strain in the specimen is increased, what happens to the resistance of the wire?

- A** It decreases, because the length decreases and the cross-sectional area increases.  
**B** It decreases, because the length increases and the cross-sectional area decreases.  
**C** It increases, because the length decreases and the cross-sectional area increases.  
**D** It increases, because the length increases and the cross-sectional area decreases.

- 46 The graph shows how the electric current  $I$  through a conducting liquid varies with the potential difference  $V$  across it.

9702/01/O/N/05/Q34

At which point on the graph does the liquid have the smallest resistance?

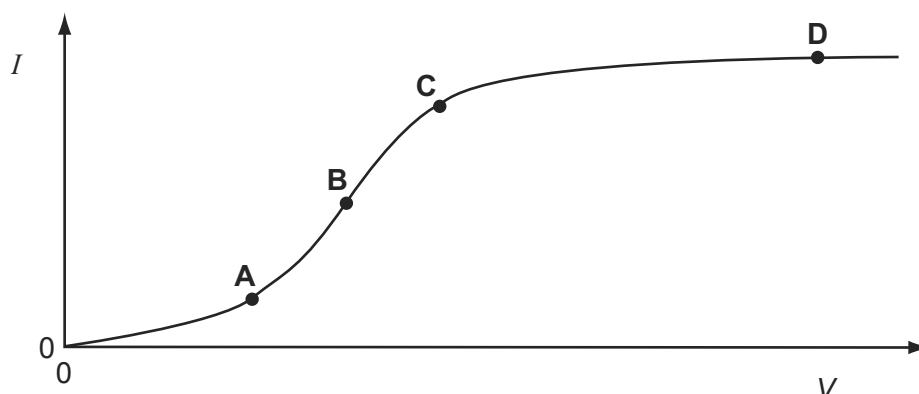

- 47 An electrical component has the following circuit symbol.

9702/01/O/N/05/Q35

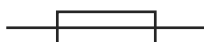

What does this symbol represent?

- A** variable resistor (rheostat)  
**B** fuse  
**C** light-dependent resistor  
**D** thermistor
- 48 Three resistors are connected in series with a battery as shown in the diagram. The battery has negligible internal resistance.

9702/01/O/N/05/Q36

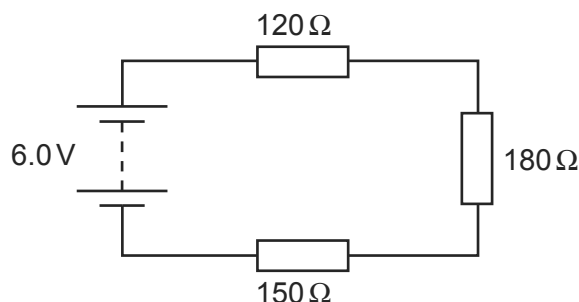

What is the potential difference across the  $180\Omega$  resistor?

- A** 1.6V      **B** 2.4V      **C** 3.6V      **D** 6.0V
- 49 Two heating coils X and Y, of resistance  $R_X$  and  $R_Y$  respectively, deliver the same power when 12V is applied across X and 6V is applied across Y.

9702/01/O/N/07/Q29

What is the ratio  $R_X/R_Y$ ?

- A**  $\frac{1}{4}$       **B**  $\frac{1}{2}$       **C** 2      **D** 4

- 50 In the circuit below, the reading  $V_T$  on the voltmeter changes from high to low as the temperature of the thermistor changes. The reading  $V_L$  on the voltmeter changes from high to low as the level of light on the light-dependent resistor (LDR) changes.

9702/01/O/N/05/Q37

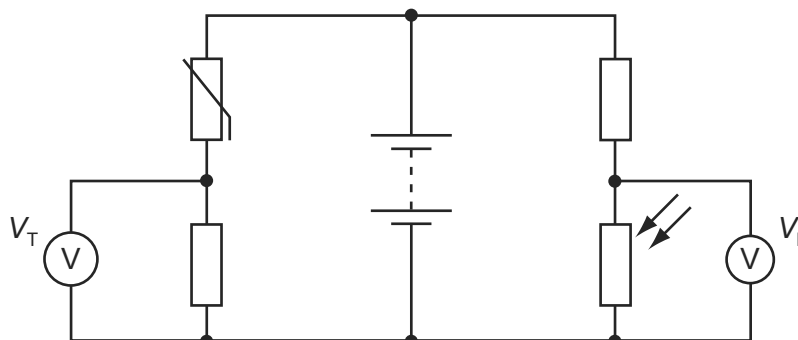

The readings on  $V_T$  and  $V_L$  are both high.

What are the conditions of temperature and light level?

	temperature	light level
<b>A</b>	low	low
<b>B</b>	low	high
<b>C</b>	high	low
<b>D</b>	high	high

- 51 The diagram shows an arrangement of resistors.

9702/01/M/J/06/Q35

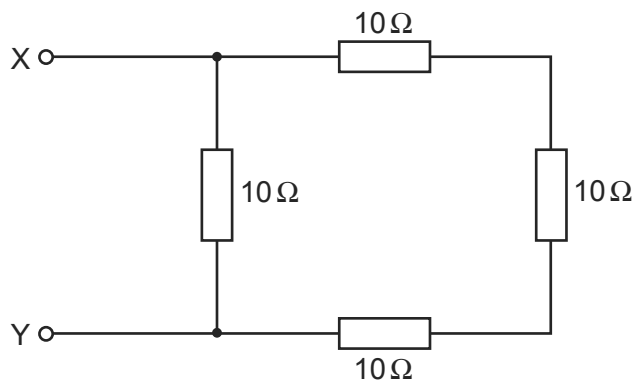

What is the total electrical resistance between X and Y?

- A** less than  $1\ \Omega$
- B** between  $1\ \Omega$  and  $10\ \Omega$
- C** between  $10\ \Omega$  and  $30\ \Omega$
- D**  $40\ \Omega$

- 52 The current in the circuit is 4.8 A.

9702/01/M/J/06/Q31

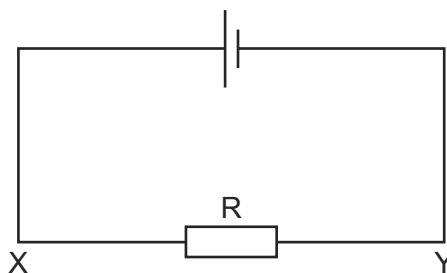

What is the rate of flow and the direction of flow of electrons through the resistor R?

- A**  $3.0 \times 10^{19} \text{ s}^{-1}$  in direction X to Y  
**B**  $6.0 \times 10^{18} \text{ s}^{-1}$  in direction X to Y  
**C**  $3.0 \times 10^{19} \text{ s}^{-1}$  in direction Y to X  
**D**  $6.0 \times 10^{18} \text{ s}^{-1}$  in direction Y to X

- 53 A p.d. of 12 V is connected between P and Q.

9702/01/M/J/06/Q33

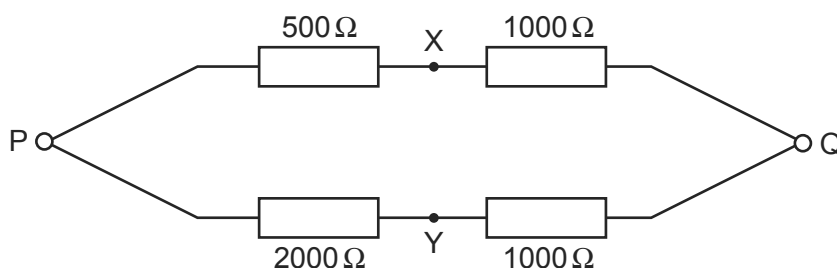

What is the p.d. between X and Y?

- A** 0 V                      **B** 4 V                      **C** 6 V                      **D** 8 V

- 54 The diagram shows a low-voltage circuit for heating the water in a fish tank.

9702/01/M/J/06/Q34

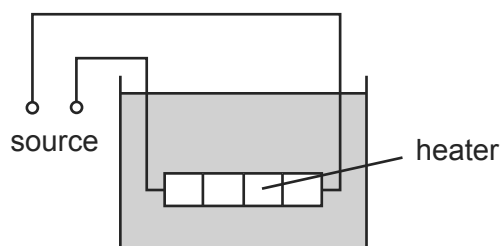

The heater has a resistance of  $3.0 \Omega$ . The voltage source has an e.m.f. of 12 V and an internal resistance of  $1.0 \Omega$ .

At what rate does the voltage source supply energy to the heater?

- A** 27 W                      **B** 36 W                      **C** 48 W                      **D** 64 W



- 55 When four identical lamps P, Q, R and S are connected as shown in diagram 1, they have normal brightness.

9702/01/M/J/06/Q36

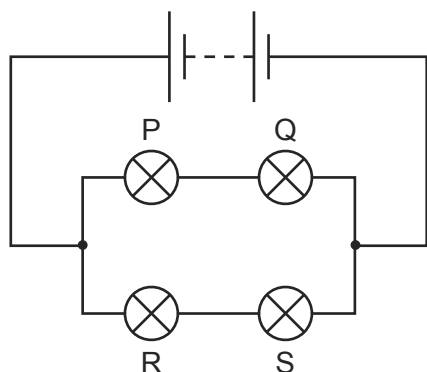

diagram 1

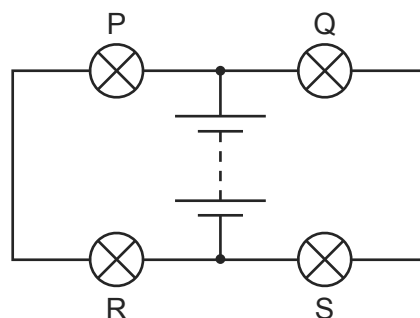

diagram 2

The four lamps and the battery are then connected as shown in diagram 2.

Which statement is correct?

- A** The lamps do not light.
  - B** The lamps are less bright than normal.
  - C** The lamps have normal brightness.
  - D** The lamps are brighter than normal.
- 56 The diagram shows a light-dependent resistor (LDR) and a thermistor forming a potential divider.

9702/01/M/J/06/Q37

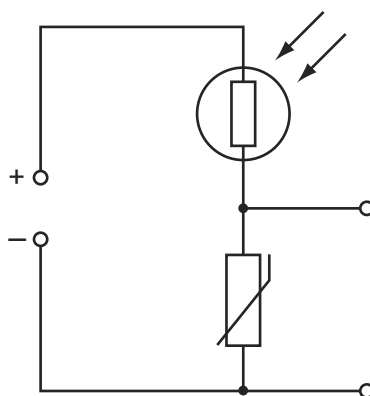

Under which set of conditions will the potential difference across the thermistor have the greatest value?

	illumination	temperature
<b>A</b>	low	low
<b>B</b>	high	low
<b>C</b>	low	high
<b>D</b>	high	high

57 Which graph shows the  $I - V$  characteristic of a filament lamp?

9702/01/O/N/06/Q32

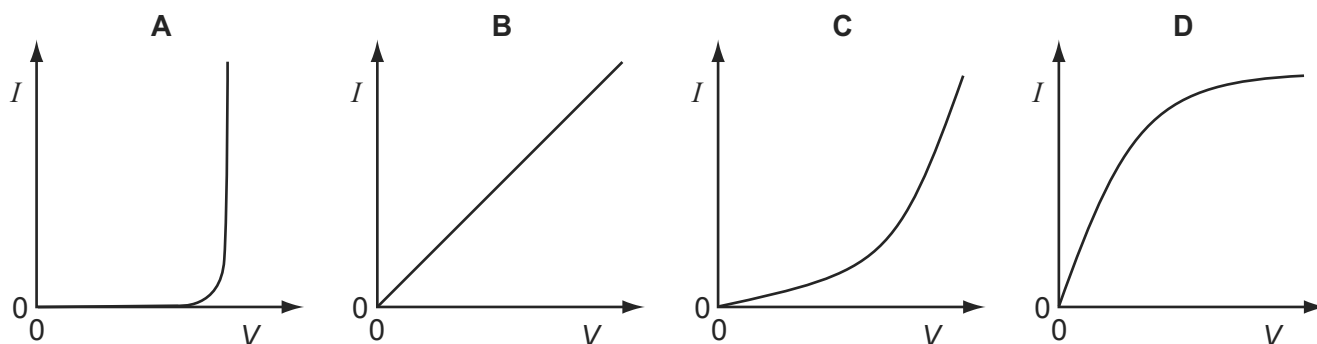

58 The resistance of a device is designed to change with temperature.

9702/01/O/N/06/Q35

What is the device?

- A** a light-dependent resistor
- B** a potential divider
- C** a semiconductor diode
- D** a thermistor

59 The diagram represents a circuit.

9702/01/O/N/06/Q36

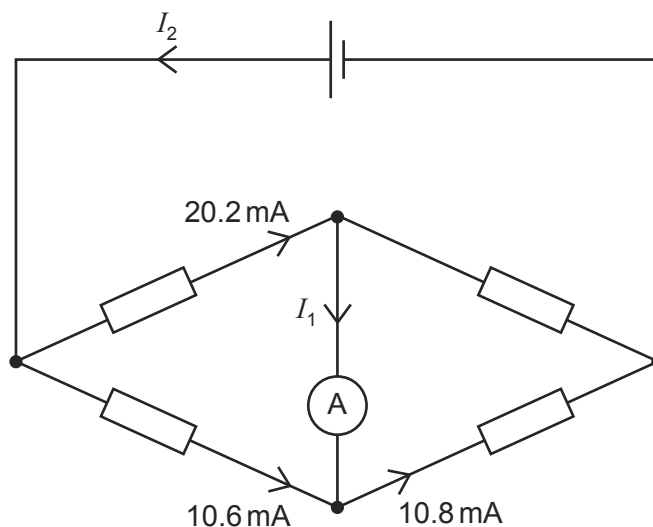

Some currents have been shown on the diagram.

What are the currents  $I_1$  and  $I_2$ ?

	$I_1$	$I_2$
<b>A</b>	0.2 mA	10.8 mA
<b>B</b>	0.2 mA	30.8 mA
<b>C</b>	-0.2 mA	20.0 mA
<b>D</b>	-0.2 mA	30.8 mA

- 60 An electrical component has a potential difference  $V$  across it and a current  $I$  through it. A graph of  $I$  against  $V$  is drawn and is marked in three sections WX, XY and YZ.

9702/01/O/N/06/Q33

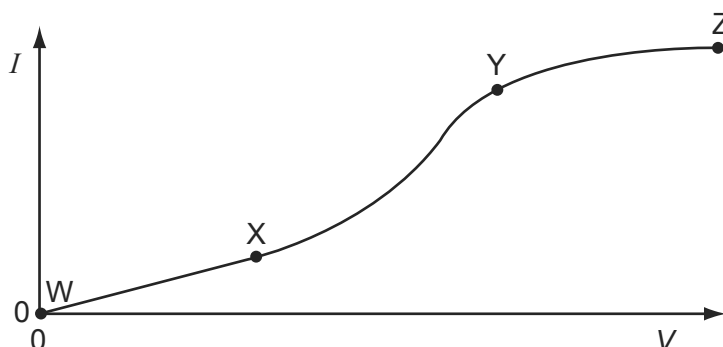

In which ways does the resistance of the component vary within each of the three sections?

	WX	XY	YZ
<b>A</b>	constant	decreases	increases
<b>B</b>	constant	increases	increases
<b>C</b>	increases	decreases	constant
<b>D</b>	increases	increases	decreases

- 61 The diagram shows a potentiometer and a fixed resistor connected across a 12 V battery of negligible internal resistance.

9702/01/O/N/06/Q34

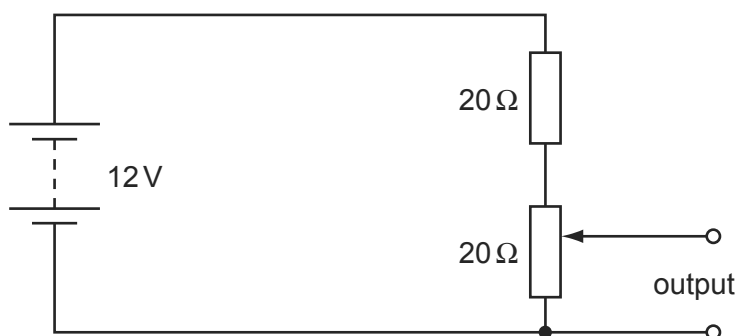

The fixed resistor and the potentiometer each have resistance  $20\ \Omega$ . The circuit is designed to provide a variable output voltage.

What is the range of output voltages?

- A** 0–6V      **B** 0–12V      **C** 6–12V      **D** 12–20V
- 62 The current in a resistor is 8.0 mA.

9702/01/M/J/07/Q32

What charge flows through the resistor in 0.020 s?

- A** 0.16 mC      **B** 1.6 mC      **C** 4.0 mC      **D** 0.40 C

63 Which circuit has a resistance of  $40\ \Omega$  between the terminals?

9702/01/O/N/06/Q37

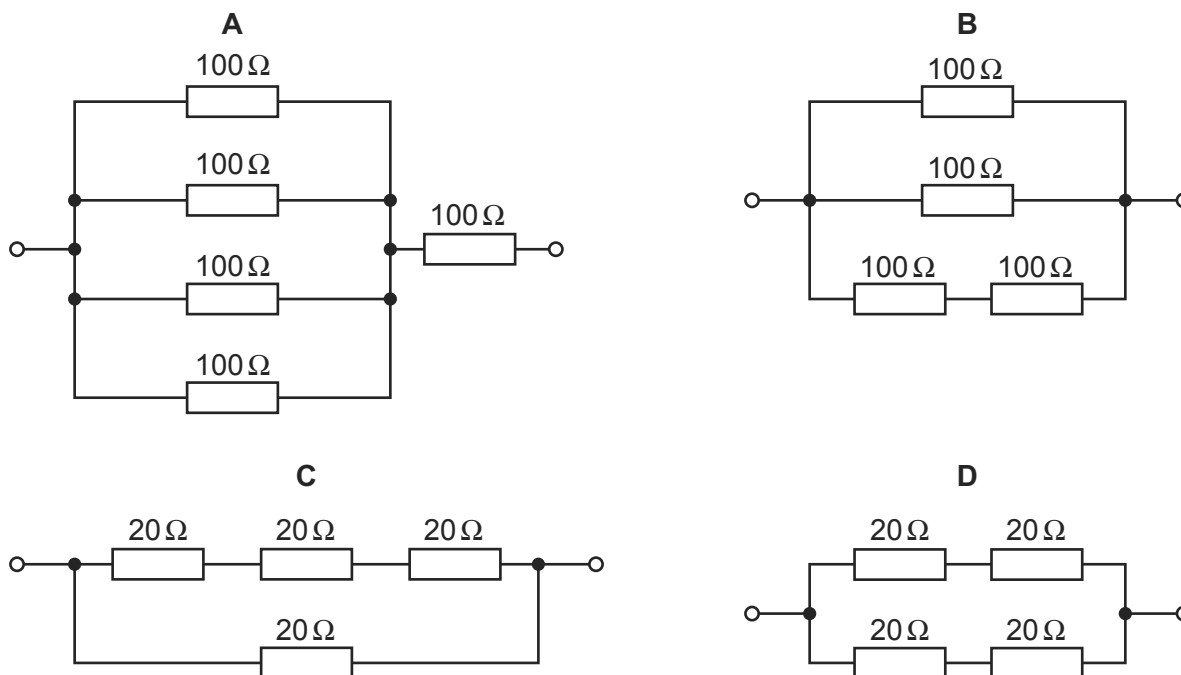

64 What is a correct statement of Ohm's law?

9702/01/M/J/07/Q31

- A** The potential difference across a component equals the current providing the resistance and other physical conditions stay constant.
- B** The potential difference across a component equals the current multiplied by the resistance.
- C** The potential difference across a component is proportional to its resistance.
- D** The potential difference across a component is proportional to the current in it providing physical conditions stay constant.

65 A circuit is set up with an LDR and a fixed resistor as shown.

9702/01/M/J/07/Q34

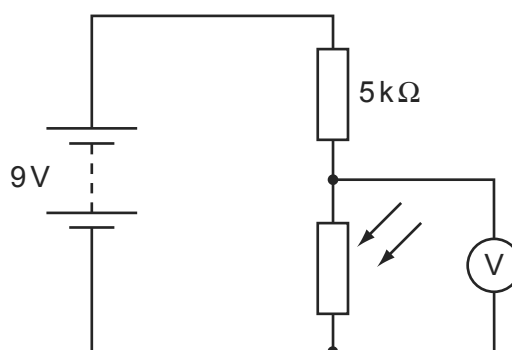

The voltmeter reads  $4\text{ V}$ .

The light intensity is increased.

What is a possible voltmeter reading?

- A**  $3\text{ V}$
- B**  $4\text{ V}$
- C**  $6\text{ V}$
- D**  $8\text{ V}$

- 66 A cell of e.m.f. 2.0 V and negligible internal resistance is connected to the network of resistors shown.

9702/01/M/J/07/Q33

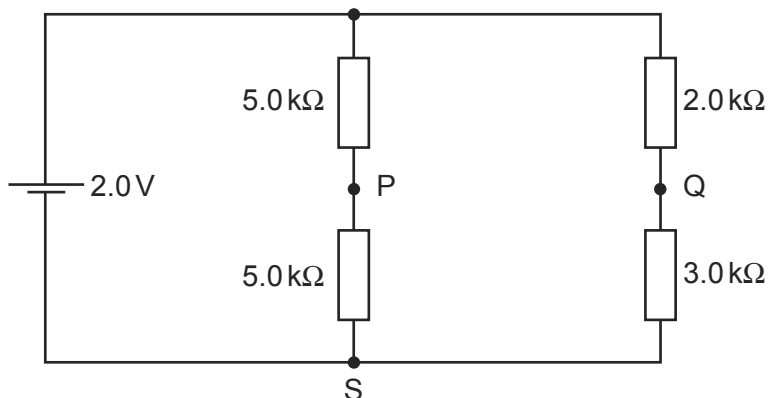

$V_1$  is the potential difference between S and P.  $V_2$  is the potential difference between S and Q.

What is the value of  $V_1 - V_2$ ?

- A** +0.50 V      **B** +0.20 V      **C** -0.20 V      **D** -0.50 V
- 67 A researcher has two pieces of copper of the same volume. All of the first piece is made into a cylindrical resistor P of length  $x$ .

9702/01/M/J/07/Q37

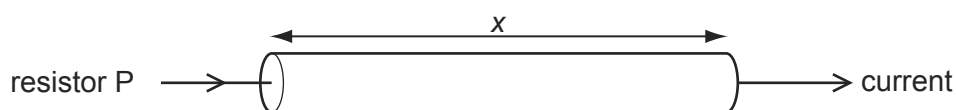

All of the second piece is made into uniform wires each of the same length  $x$  which he connects between two bars of negligible resistance to form a resistor Q.

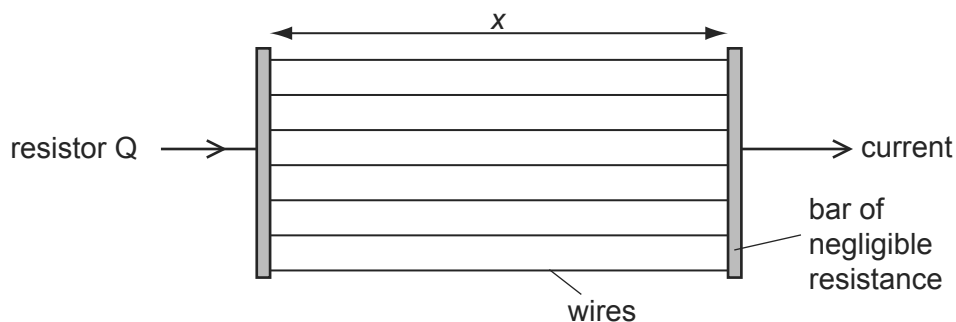

How do the electrical resistances of P and Q compare?

- A** P has a larger resistance than Q.  
**B** Q has a larger resistance than P.  
**C** P and Q have equal resistance.  
**D** Q may have a larger or smaller resistance than P, depending on the number of wires made.

- 68 In the circuit below, the battery converts an amount  $E$  of chemical energy to electrical energy when charge  $Q$  passes through the resistor in time  $t$ .

9702/01/M/J/07/Q35

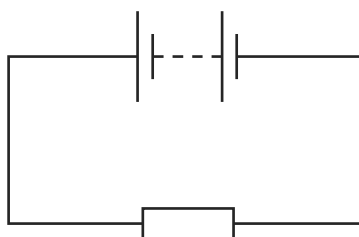

Which expressions give the e.m.f. of the battery and the current in the resistor?

	e.m.f.	current
<b>A</b>	$EQ$	$Q/t$
<b>B</b>	$EQ$	$Qt$
<b>C</b>	$E/Q$	$Q/t$
<b>D</b>	$E/Q$	$Qt$

- 69 A battery has an e.m.f. of  $3.0\text{ V}$  and an internal resistance of  $2.0\ \Omega$ .

9702/01/M/J/07/Q36

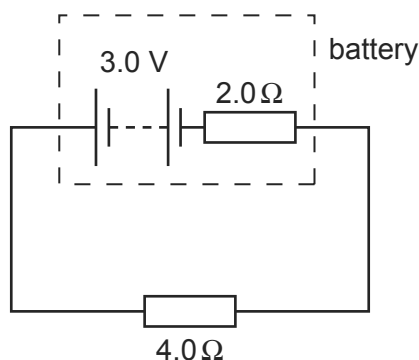

The battery is connected to a load of  $4.0\ \Omega$ .

What are the terminal potential difference  $V$  and output power  $P$ ?

	$V/\text{V}$	$P/\text{W}$
<b>A</b>	1.0	0.50
<b>B</b>	1.0	1.5
<b>C</b>	2.0	1.0
<b>D</b>	2.0	1.5

- 70 Two wires P and Q have resistances  $R_P$  and  $R_Q$  respectively. Wire P is twice as long as wire Q and has twice the diameter of wire Q. The wires are made of the same material.

9702/01/O/N/07/Q31

What is the ratio  $\frac{R_P}{R_Q}$ ?

- A** 0.5                      **B** 1                      **C** 2                      **D** 4

- 71 A battery of negligible internal resistance is connected to two  $10\Omega$  resistors in series.

9702/01/O/N/07/Q30

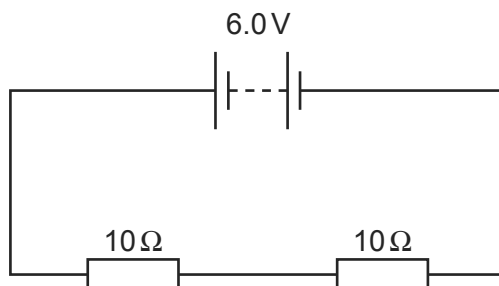

What charge flows through each of the  $10\Omega$  resistors in 1 minute?

- A** 0.30C      **B** 0.60C      **C** 3.0C      **D** 18C
- 72 A potential divider consists of a fixed resistor  $R$  and a light-dependent resistor (LDR). 9702/01/O/N/07/Q32

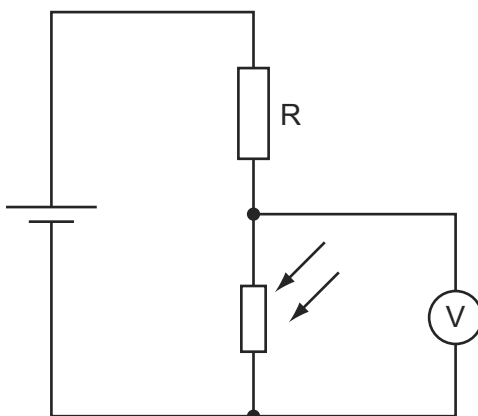

What happens to the voltmeter reading, and why does it happen, when the intensity of light on the LDR increases?

- A** The voltmeter reading decreases because the LDR resistance decreases.  
**B** The voltmeter reading decreases because the LDR resistance increases.  
**C** The voltmeter reading increases because the LDR resistance decreases.  
**D** The voltmeter reading increases because the LDR resistance increases.
- 73 A power cable X has a resistance  $R$  and carries current  $I$ . 9702/01/M/J/08/Q32

A second cable Y has a resistance  $2R$  and carries current  $\frac{1}{2}I$ .

What is the ratio  $\frac{\text{power dissipated in Y}}{\text{power dissipated in X}}$ ?

- A**  $\frac{1}{4}$       **B**  $\frac{1}{2}$       **C** 2      **D** 4

- 74 The circuit is designed to trigger an alarm system when the input voltage exceeds some preset value. It does this by comparing  $V_{\text{out}}$  with a fixed reference voltage, which is set at 4.8 V.

9702/01/O/N/07/Q33

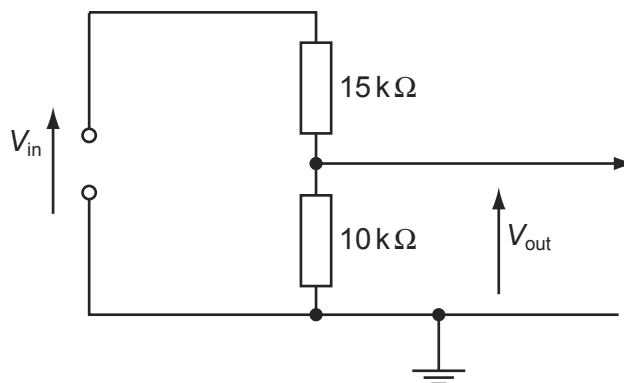

$V_{\text{out}}$  is equal to 4.8 V.

What is the input voltage  $V_{\text{in}}$ ?

- A** 4.8 V      **B** 7.2 V      **C** 9.6 V      **D** 12 V
- 75 A potentiometer is used as shown to compare the e.m.f.s of two cells.

9702/01/O/N/07/Q34

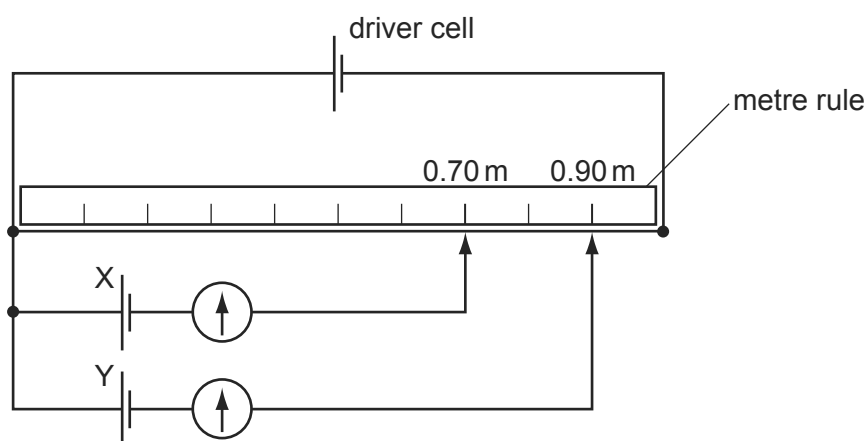

The balance points for cells X and Y are 0.70 m and 0.90 m respectively.

If the e.m.f. of cell X is 1.1 V, what is the e.m.f. of cell Y?

- A** 0.69 V      **B** 0.86 V      **C** 0.99 V      **D** 1.4 V
- 76 Which electrical quantity would be the result of a calculation in which energy transfer is divided by charge?

9702/01/O/N/07/Q28

- A** current  
**B** potential difference  
**C** power  
**D** resistance



- 77 When four identical resistors are connected as shown in diagram 1, the ammeter reads 1.0 A and the voltmeter reads zero.

9702/01/O/N/07/Q35

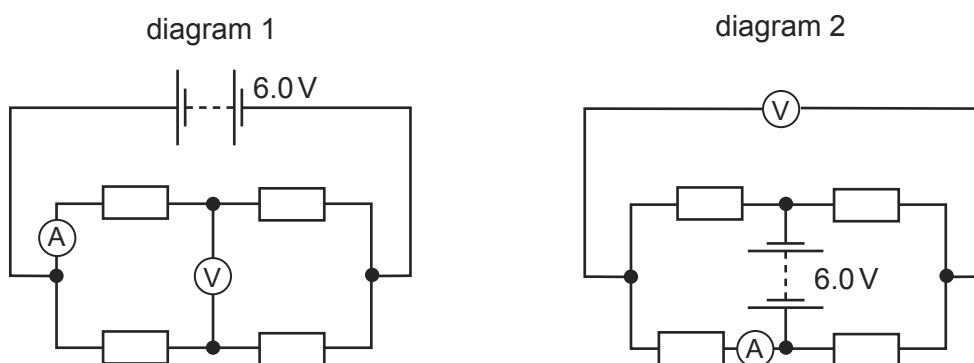

The resistors and meters are reconnected to the supply as shown in diagram 2.

What are the meter readings in diagram 2?

	voltmeter reading / V	ammeter reading / A
<b>A</b>	0	1.0
<b>B</b>	3.0	0.5
<b>C</b>	3.0	1.0
<b>D</b>	6.0	0

- 78 A total charge of 100 C flows through a 12 W light bulb in a time of 50 s.

9702/01/M/J/08/Q33

What is the potential difference across the bulb during this time?

- A** 0.12 V      **B** 2.0 V      **C** 6.0 V      **D** 24 V

- 79 Two copper wires X and Y have the same volume. Wire Y is four times as long as wire X.

9702/01/M/J/08/Q34

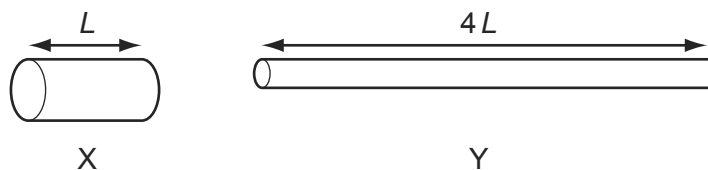

What is the ratio  $\frac{\text{resistance of wire Y}}{\text{resistance of wire X}}$ ?

- A** 4      **B** 8      **C** 16      **D** 64

- 80 The charge that a fully-charged 12 V car battery can supply is 100 kC. The starter motor of the car requires a current of 200 A for an average period of 2.0 s. The battery does not recharge because of a fault.

9702/01/O/N/08/Q34

What is the maximum number of times the starter motor of the car can be used?

- A** 21      **B** 25      **C** 42      **D** 250

- 81 The potential difference across a resistor is 12V. The current in the resistor is 2.0A. 4.0C passes through the resistor.

What is the energy transferred and the time taken?

	energy / J	time / s
<b>A</b>	3.0	2.0
<b>B</b>	3.0	8.0
<b>C</b>	48	2.0
<b>D</b>	48	8.0

- 82 A thermistor and another component are connected to a constant voltage supply. A voltmeter is connected across one of the components. The temperature of the thermistor is then reduced but no other changes are made.

9702/01/M/J/08/Q36

In which circuit will the voltmeter reading increase?

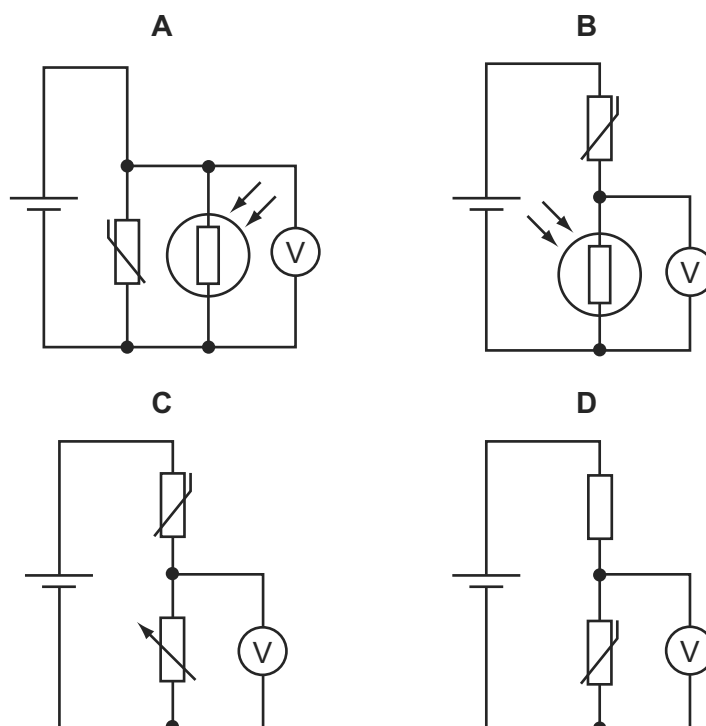

- 83 Two wires P and Q made of the same material and of the same length are connected in parallel to the same voltage supply. Wire P has diameter 2 mm and wire Q has diameter 1 mm.

9702/01/O/N/08/Q31

What is the ratio  $\frac{\text{current in P}}{\text{current in Q}}$  ?

- A**  $\frac{1}{4}$       **B**  $\frac{1}{2}$       **C**  $\frac{2}{1}$       **D**  $\frac{4}{1}$

- 84 In the circuit shown, the 6.0 V battery has negligible internal resistance. Resistors  $R_1$  and  $R_2$  and the voltmeter have resistance  $100\text{ k}\Omega$ .

9702/01/M/J/08/Q37

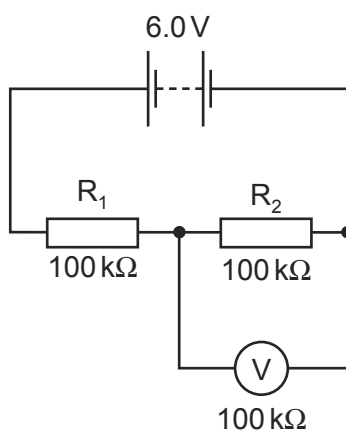

What is the current in the resistor  $R_2$ ?

- A  $20\ \mu\text{A}$       B  $30\ \mu\text{A}$       C  $40\ \mu\text{A}$       D  $60\ \mu\text{A}$
- 85 The unknown e.m.f.  $E$  of a cell is to be determined using a potentiometer circuit. The balance length is to be measured when the galvanometer records a null reading.

9702/01/M/J/08/Q38

What is the correct circuit to use?

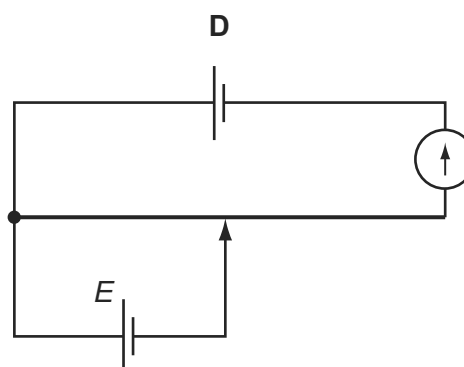
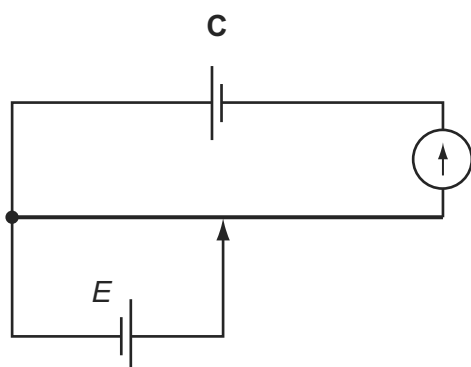
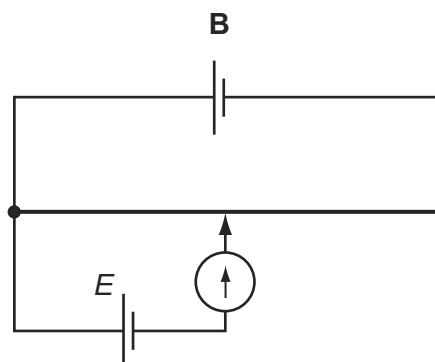
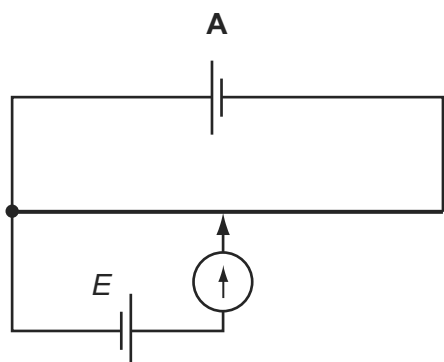

- 86 A 12 V battery is charged for 20 minutes by connecting it to a source of electromotive force (e.m.f.). The battery is supplied with  $7.2 \times 10^4\text{ J}$  of energy in this time.

9702/01/M/J/09/Q31

How much charge flows into the battery?

- A 5.0 C      B 60 C      C 100 C      D 6000 C

- 87 An electric power cable consists of six copper wires *c* surrounding a steel core *s*. 9702/01/O/N/08/Q32

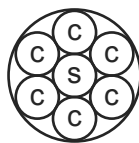

1.0 km of one of the copper wires has a resistance of  $10\ \Omega$  and 1.0 km of the steel core has a resistance of  $100\ \Omega$ .

What is the approximate resistance of a 1.0 km length of the power cable?

- A**  $0.61\ \Omega$       **B**  $1.6\ \Omega$       **C**  $160\ \Omega$       **D**  $610\ \Omega$
- 88 Which graph best represents the way the current  $I$  through a filament lamp varies with the potential difference  $V$  across it? 9702/01/O/N/08/Q33

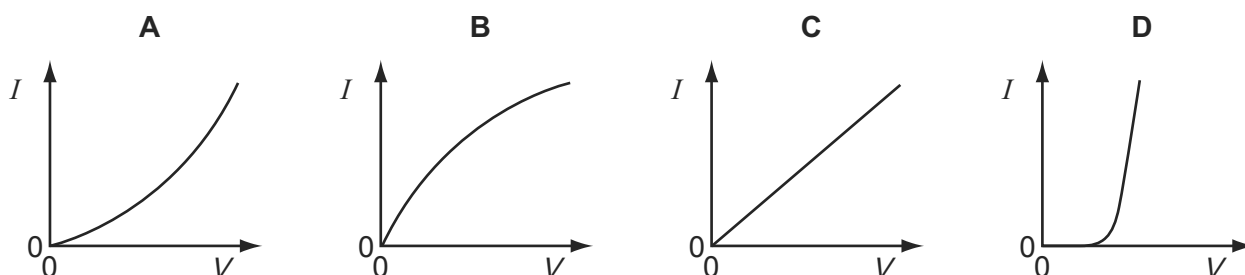

- 89 The diagram shows a circuit containing three resistors in parallel. 9702/01/O/N/08/Q35

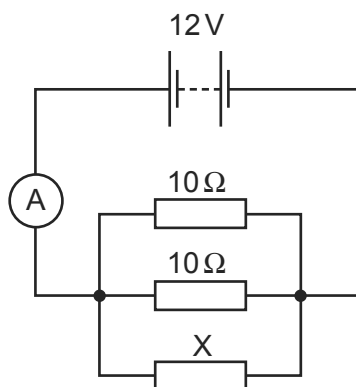

The battery has e.m.f.  $12\text{V}$  and negligible internal resistance. The ammeter reading is  $3.2\text{A}$ .

What is the resistance of  $X$ ?

- A**  $2.1\ \Omega$       **B**  $4.6\ \Omega$       **C**  $6.0\ \Omega$       **D**  $15\ \Omega$
- 90 A copper wire is cylindrical and has resistance  $R$ . 9702/11/O/N/10/Q33

What will be the resistance of a copper wire of twice the length and twice the radius?

- A**  $\frac{R}{4}$       **B**  $\frac{R}{2}$       **C**  $R$       **D**  $2R$

- 91 The e.m.f. of the battery is 9.0V. The reading on the high-resistance voltmeter is 7.5V.

9702/01/O/N/08/Q36

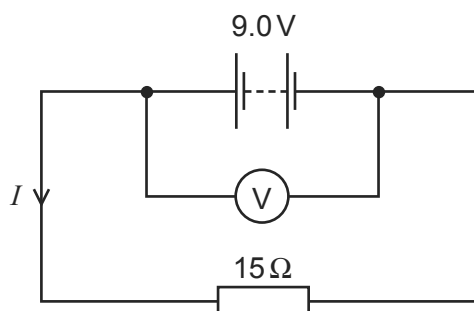

What is the current  $I$ ?

- 92 The diagram shows a potentiometer circuit.

9702/01/O/N/08/Q37

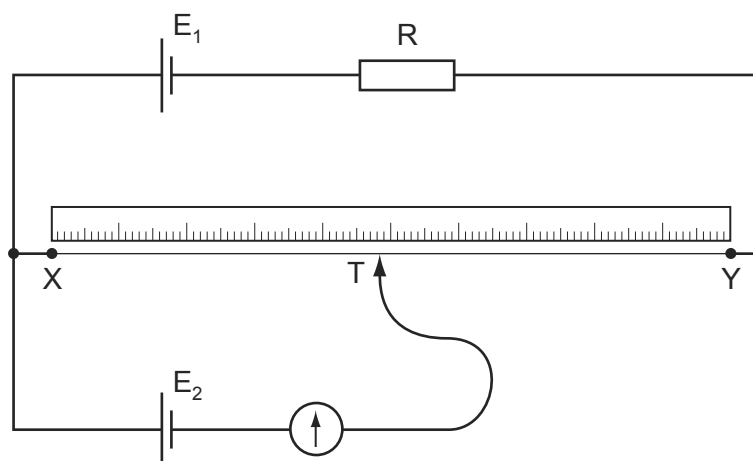

The contact  $T$  is placed on the wire and moved along the wire until the galvanometer reading is zero. The length  $XT$  is then noted.

In order to calculate the potential difference per unit length on the wire  $XY$ , which value must also be known?

- A** the e.m.f. of the cell  $E_1$   
**B** the e.m.f. of the cell  $E_2$   
**C** the resistance of resistor  $R$   
**D** the resistance of the wire  $XY$
- 93 What is the unit of resistivity?

9702/11/M/J/10/Q31

- A**  $\Omega\text{m}^{-2}$       **B**  $\Omega\text{m}^{-1}$       **C**  $\Omega$       **D**  $\Omega\text{m}$

- 94 What is meant by the electromotive force (e.m.f.) of a cell? 9702/01/M/J/09/Q32
- A** The e.m.f. of a cell is the energy converted into electrical energy when unit charge passes through the cell.
- B** The e.m.f. of a cell is the energy transferred by the cell in driving unit charge through the external resistance.
- C** The e.m.f. of a cell is the energy transferred by the cell in driving unit charge through the internal resistance of the cell.
- D** The e.m.f. of a cell is the amount of energy needed to bring a unit positive charge from infinity to its positive pole.
- 95 Two cells of e.m.f. 3.0 V and 1.2 V and negligible internal resistance are connected to resistors of resistance  $9.0\ \Omega$  and  $18\ \Omega$  as shown. 9702/01/M/J/09/Q33

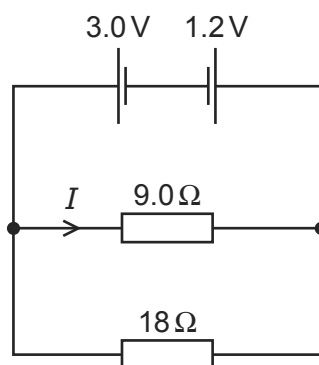

What is the value of the current  $I$  in the  $9.0\ \Omega$  resistor?

- A** 0.10 A      **B** 0.20 A      **C** 0.30 A      **D** 0.47 A
- 96 Which amount of charge, flowing in the given time, will produce the largest current? 9702/01/M/J/09/Q30

	charge / C	time / s
<b>A</b>	4	$\frac{1}{4}$
<b>B</b>	4	1
<b>C</b>	1	4
<b>D</b>	$\frac{1}{4}$	4

- 97 A source of e.m.f. of 9.0 mV has an internal resistance of  $6.0\ \Omega$ . 9702/11/M/J/10/Q35
- It is connected across a galvanometer of resistance  $30\ \Omega$ .
- What will be the current in the galvanometer?
- A**  $250\ \mu\text{A}$       **B**  $300\ \mu\text{A}$       **C** 1.5 mA      **D** 2.5 mA

- 98 Six identical  $12\ \Omega$  resistors are arranged in two groups, one with three in series and the other with three in parallel.

9702/01/M/J/09/Q34

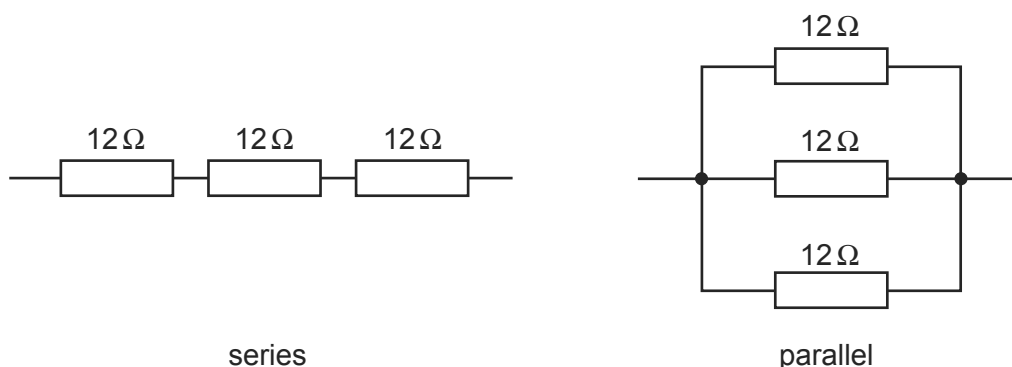

What are the combined resistances of each of these two arrangements?

	series	parallel
<b>A</b>	$4.0\ \Omega$	$0.25\ \Omega$
<b>B</b>	$4.0\ \Omega$	$36\ \Omega$
<b>C</b>	$36\ \Omega$	$0.25\ \Omega$
<b>D</b>	$36\ \Omega$	$4.0\ \Omega$

- 99 The diagrams show a light-dependent resistor in circuit P, and a thermistor in circuit Q.

9702/01/M/J/09/Q35

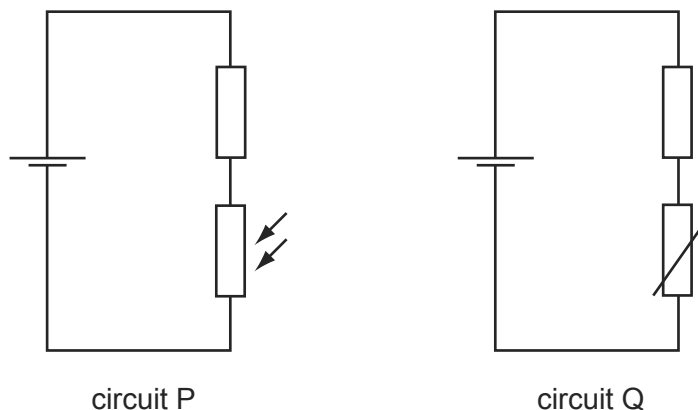

How does the potential difference across the fixed resistor in each circuit change when both the brightness of the light on the light-dependent resistor and the temperature of the thermistor are increased?

	circuit P	circuit Q
<b>A</b>	decrease	decrease
<b>B</b>	decrease	increase
<b>C</b>	increase	decrease
<b>D</b>	increase	increase

100 A cell is connected to a resistor.

9702/11/O/N/09/Q30

At any given moment, the potential difference across the cell is less than its electromotive force.

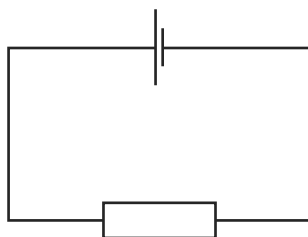

Which statement explains this?

- A** The cell is continually discharging.
- B** The connecting wire has some resistance.
- C** Energy is needed to drive charge through the cell.
- D** Power is used when there is a current in the resistor.

101 Which values of current and resistance will produce a rate of energy transfer of  $16 \text{ J s}^{-1}$ ?

9702/11/O/N/09/Q31

	current / A	resistance / $\Omega$
<b>A</b>	1	4
<b>B</b>	2	8
<b>C</b>	4	1
<b>D</b>	16	1

102 A cylindrical wire 4.0 m long has a resistance of  $31 \Omega$  and is made of metal of resistivity  $1.0 \times 10^{-6} \Omega \text{ m}$ .

9702/11/O/N/09/Q32

What is the radius of cross-section of the wire?

- A**  $1.0 \times 10^{-8} \text{ m}$
- B**  $2.0 \times 10^{-8} \text{ m}$
- C**  $6.4 \times 10^{-8} \text{ m}$
- D**  $2.0 \times 10^{-4} \text{ m}$

103 A source of e.m.f. of 9.0 mV has an internal resistance of  $6.0 \Omega$ .

9702/12/M/J/10/Q33

It is connected across a galvanometer of resistance  $30 \Omega$ .

What will be the current in the galvanometer?

- A**  $250 \mu\text{A}$
- B**  $300 \mu\text{A}$
- C**  $1.5 \text{ mA}$
- D**  $2.5 \text{ mA}$



104 Each of Kirchhoff's two laws presumes that some quantity is conserved.

9702/11/O/N/09/Q33

Which row states Kirchhoff's **first** law and names the quantity that is conserved?

	statement	quantity
<b>A</b>	the algebraic sum of currents into a junction is zero	charge
<b>B</b>	the algebraic sum of currents into a junction is zero	energy
<b>C</b>	the e.m.f. in a loop is equal to the algebraic sum of the product of current and resistance round the loop	charge
<b>D</b>	the e.m.f. in a loop is equal to the algebraic sum of the product of current and resistance round the loop	energy

105 The diagram shows the symbol for a wire carrying a current  $I$ .

9702/11/O/N/09/Q34

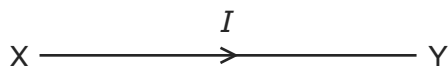

What does this current represent?

- A** the amount of charge flowing past a point in XY per second
- B** the number of electrons flowing past a point in XY per second
- C** the number of positive ions flowing past a point in XY per second
- D** the number of protons flowing past a point in XY per second

106 A network of resistors consists of two  $3.0\ \Omega$  resistors and three  $6.0\ \Omega$  resistors.

9702/11/O/N/09/Q36

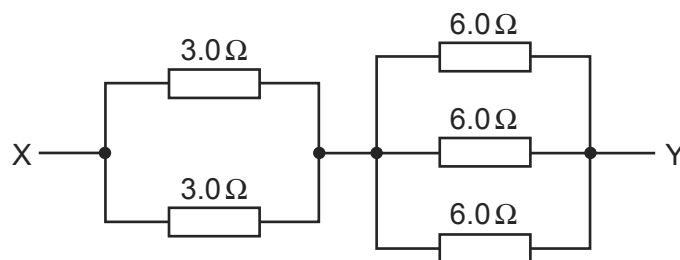

What is the combined resistance of this network between points X and Y?

- A**  $0.86\ \Omega$
- B**  $1.2\ \Omega$
- C**  $3.5\ \Omega$
- D**  $24\ \Omega$

- 107 A potential divider consisting of resistors of resistance  $R_1$  and  $R_2$  is connected to an input potential difference of  $V_0$  and gives an output p.d. of  $V$ .

9702/11/O/N/09/Q35

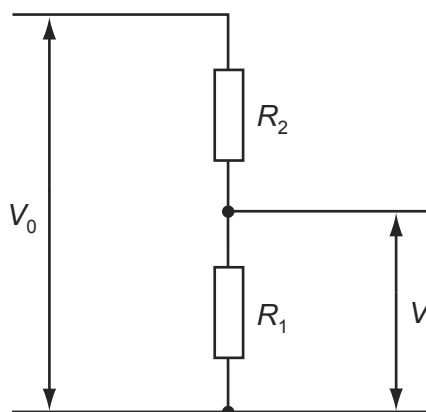

What is the value of  $V$ ?

- A  $\frac{V_0 R_1}{R_2}$       B  $\frac{V_0 R_1}{R_1 + R_2}$       C  $\frac{V_0 R_2}{R_1 + R_2}$       D  $\frac{V_0 (R_1 + R_2)}{R_1}$

- 108 A cell is connected to a resistor.

9702/12/O/N/09/Q29

At any given moment, the potential difference across the cell is less than its electromotive force.

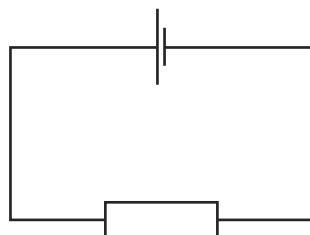

Which statement explains this?

- A The cell is continually discharging.  
 B The connecting wire has some resistance.  
 C Energy is needed to drive charge through the cell.  
 D Power is used when there is a current in the resistor.
- 109 A cylindrical wire 4.0 m long has a resistance of  $31 \Omega$  and is made of metal of resistivity  $1.0 \times 10^{-6} \Omega \text{m}$ .

9702/12/O/N/09/Q31

What is the radius of cross-section of the wire?

- A  $1.0 \times 10^{-8} \text{m}$   
 B  $2.0 \times 10^{-8} \text{m}$   
 C  $6.4 \times 10^{-8} \text{m}$   
 D  $2.0 \times 10^{-4} \text{m}$

110 Which values of current and resistance will produce a rate of energy transfer of  $16 \text{ J s}^{-1}$ ?

9702/12/O/N/09/Q30

	current/A	resistance/ $\Omega$
<b>A</b>	1	4
<b>B</b>	2	8
<b>C</b>	4	1
<b>D</b>	16	1

111 Each of Kirchhoff's two laws presumes that some quantity is conserved.

9702/12/O/N/09/Q32

Which row states Kirchhoff's **first** law and names the quantity that is conserved?

	statement	quantity
<b>A</b>	the algebraic sum of currents into a junction is zero	charge
<b>B</b>	the algebraic sum of currents into a junction is zero	energy
<b>C</b>	the e.m.f. in a loop is equal to the algebraic sum of the product of current and resistance round the loop	charge
<b>D</b>	the e.m.f. in a loop is equal to the algebraic sum of the product of current and resistance round the loop	energy

112 The diagram shows the symbol for a wire carrying a current  $I$ .

9702/12/O/N/09/Q33

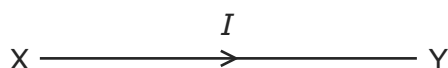

What does this current represent?

- A** the amount of charge flowing past a point in XY per second
- B** the number of electrons flowing past a point in XY per second
- C** the number of positive ions flowing past a point in XY per second
- D** the number of protons flowing past a point in XY per second

- 113 A potential divider consisting of resistors of resistance  $R_1$  and  $R_2$  is connected to an input potential difference of  $V_0$  and gives an output p.d. of  $V$ .

9702/12/O/N/09/Q34

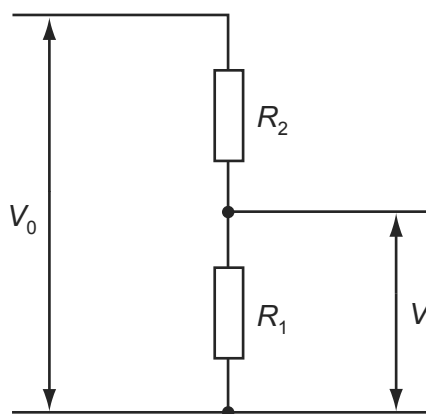

What is the value of  $V$ ?

- A  $\frac{V_0 R_1}{R_2}$       B  $\frac{V_0 R_1}{R_1 + R_2}$       C  $\frac{V_0 R_2}{R_1 + R_2}$       D  $\frac{V_0 (R_1 + R_2)}{R_1}$

- 114 A network of resistors consists of two  $3.0\Omega$  resistors and three  $6.0\Omega$  resistors.

9702/12/O/N/09/Q35

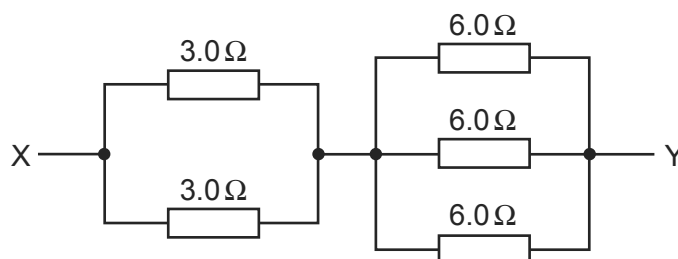

What is the combined resistance of this network between points X and Y?

- A  $0.86\Omega$       B  $1.2\Omega$       C  $3.5\Omega$       D  $24\Omega$

- 115 The resistors P, Q and R in the circuit have equal resistance.

9702/11/M/J/10/Q33

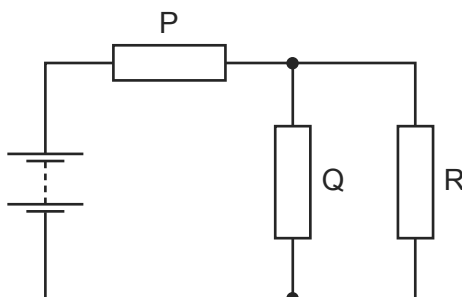

The battery, of negligible internal resistance, supplies a total power of  $12\text{W}$ .

What is the power dissipated by heating in resistor R?

- A  $2\text{W}$       B  $3\text{W}$       C  $4\text{W}$       D  $6\text{W}$

- 116 The resistance of a thermistor depends on its temperature, and the resistance of a light-dependent resistor (LDR) depends on the illumination. 9702/11/M/J/10/Q32

Under which conditions will the resistance of both a thermistor and an LDR be highest?

	thermistor	LDR
<b>A</b>	highest temperature	highest illumination
<b>B</b>	highest temperature	lowest illumination
<b>C</b>	lowest temperature	highest illumination
<b>D</b>	lowest temperature	lowest illumination

- 117 In deriving a formula for the combined resistance of three different resistors in series, Kirchhoff's laws are used. 9702/11/M/J/10/Q34

Which physics principle is involved in this derivation?

- A** the conservation of charge  
**B** the direction of the flow of charge is from negative to positive  
**C** the potential difference across each resistor is the same  
**D** the current varies in each resistor, in proportion to the resistor value
- 118 In each arrangement of resistors, the ammeter has a resistance of  $2\Omega$ . 9702/11/M/J/10/Q36

Which arrangement gives the largest reading on the ammeter when the same potential difference is applied between points P and Q?

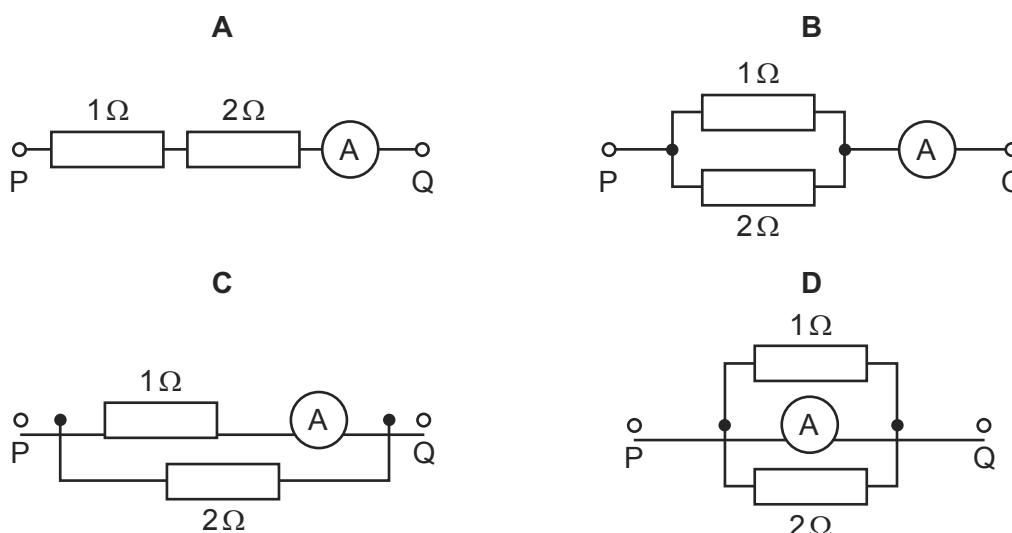

- 119 What is the unit of resistivity? 9702/12/M/J/10/Q36
- A**  $\Omega\text{m}^{-2}$       **B**  $\Omega\text{m}^{-1}$       **C**  $\Omega$       **D**  $\Omega\text{m}$

- 120 The resistance of a thermistor depends on its temperature, and the resistance of a light-dependent resistor (LDR) depends on the illumination. 9702/12/M/J/10/Q30

Under which conditions will the resistance of both a thermistor and an LDR be highest?

	thermistor	LDR
<b>A</b>	highest temperature	highest illumination
<b>B</b>	highest temperature	lowest illumination
<b>C</b>	lowest temperature	highest illumination
<b>D</b>	lowest temperature	lowest illumination

- 121 In each arrangement of resistors, the ammeter has a resistance of  $2\ \Omega$ . 9702/12/M/J/10/Q32

Which arrangement gives the largest reading on the ammeter when the same potential difference is applied between points P and Q?

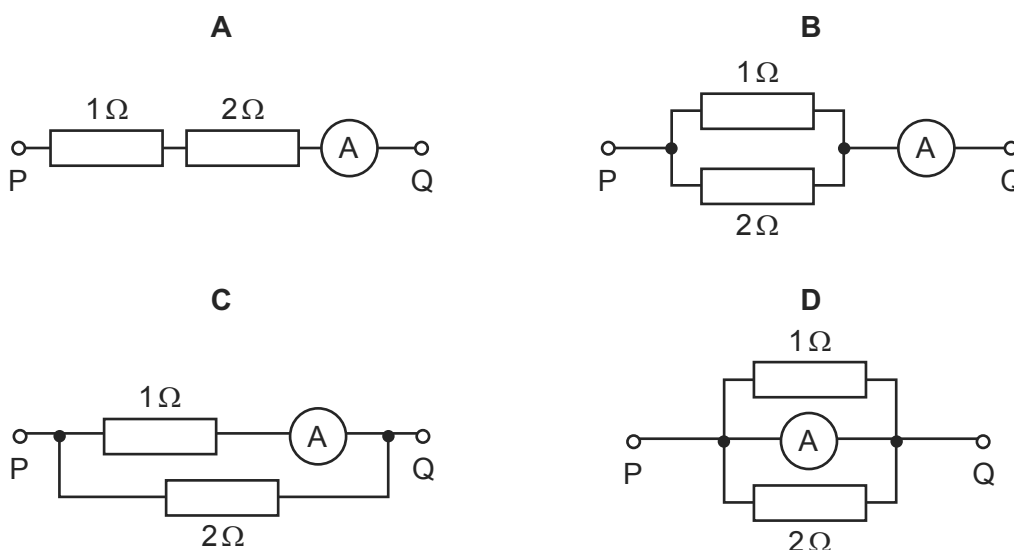

- 122 The resistance of a thermistor depends on its temperature, and the resistance of a light-dependent resistor (LDR) depends on the illumination. 9702/13/M/J/10/Q33

Under which conditions will the resistance of both a thermistor and an LDR be highest?

	thermistor	LDR
<b>A</b>	highest temperature	highest illumination
<b>B</b>	highest temperature	lowest illumination
<b>C</b>	lowest temperature	highest illumination
<b>D</b>	lowest temperature	lowest illumination

123 The resistors P, Q and R in the circuit have equal resistance.

9702/12/M/J/10/Q34

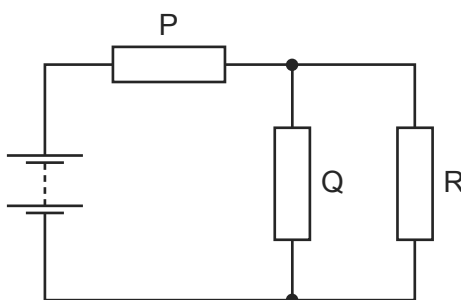

The battery, of negligible internal resistance, supplies a total power of 12 W.

What is the power dissipated by heating in resistor R?

- A** 2 W                      **B** 3 W                      **C** 4 W                      **D** 6 W

124 In deriving a formula for the combined resistance of three different resistors in series, Kirchhoff's laws are used.

9702/12/M/J/10/Q35

Which physics principle is involved in this derivation?

- A** the conservation of charge  
**B** the direction of the flow of charge is from negative to positive  
**C** the potential difference across each resistor is the same  
**D** the current varies in each resistor, in proportion to the resistor value

125 A source of e.m.f. of 9.0 mV has an internal resistance of 6.0  $\Omega$ .

9702/13/M/J/10/Q31

It is connected across a galvanometer of resistance 30  $\Omega$ .

What will be the current in the galvanometer?

- A** 250  $\mu$ A                      **B** 300  $\mu$ A                      **C** 1.5 mA                      **D** 2.5 mA

126 In deriving a formula for the combined resistance of three different resistors in series, Kirchhoff's laws are used.

9702/13/M/J/10/Q36

Which physics principle is involved in this derivation?

- A** the conservation of charge  
**B** the direction of the flow of charge is from negative to positive  
**C** the potential difference across each resistor is the same  
**D** the current varies in each resistor, in proportion to the resistor value

127 In each arrangement of resistors, the ammeter has a resistance of  $2\Omega$ .

9702/13/M/J/10/Q34

Which arrangement gives the largest reading on the ammeter when the same potential difference is applied between points P and Q?

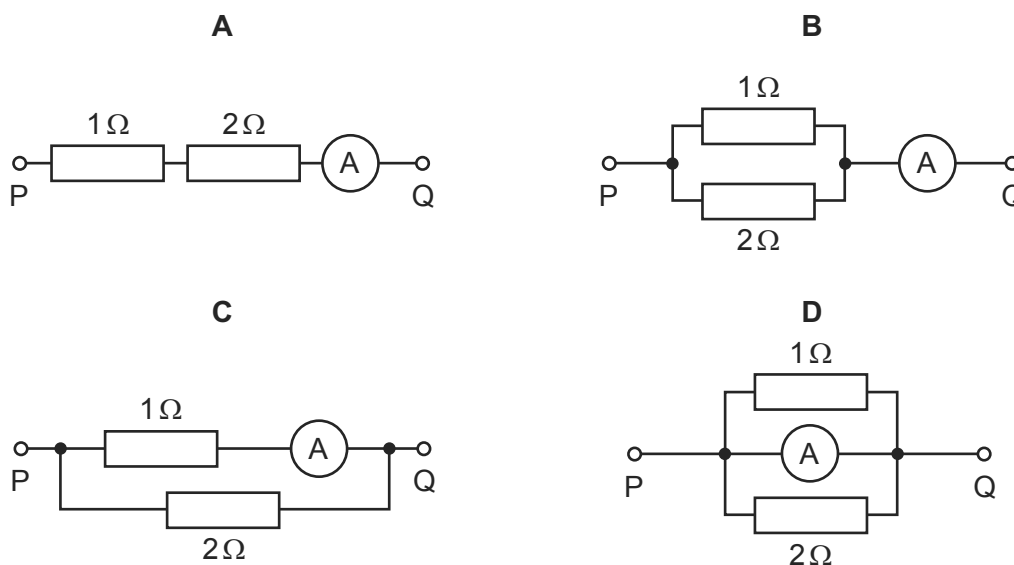

128 The resistors P, Q and R in the circuit have equal resistance.

9702/13/M/J/10/Q35

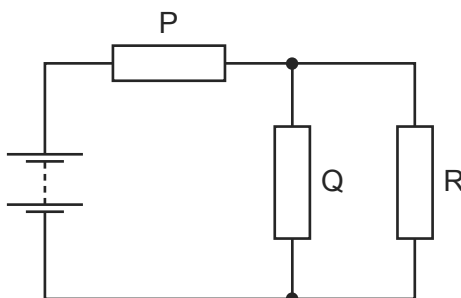

The battery, of negligible internal resistance, supplies a total power of  $12\text{W}$ .

What is the power dissipated by heating in resistor R?

- A**  $2\text{W}$       **B**  $3\text{W}$       **C**  $4\text{W}$       **D**  $6\text{W}$

129 Which electrical component is represented by the following symbol?

9702/12/O/N/10/Q30

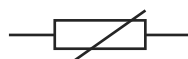

- A** a diode  
**B** a potentiometer  
**C** a resistor  
**D** a thermistor



130 The current in the circuit shown is 4.8 A.

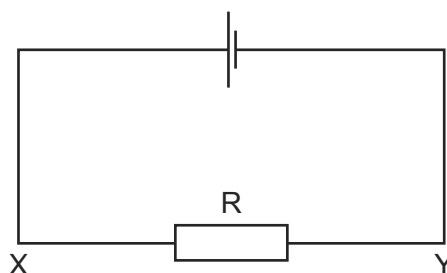

What is the direction of flow and the rate of flow of electrons through the resistor R?

	direction of flow	rate of flow
<b>A</b>	X to Y	$3.0 \times 10^{19} \text{ s}^{-1}$
<b>B</b>	X to Y	$6.0 \times 10^{18} \text{ s}^{-1}$
<b>C</b>	Y to X	$3.0 \times 10^{19} \text{ s}^{-1}$
<b>D</b>	Y to X	$6.0 \times 10^{18} \text{ s}^{-1}$

131 Which component has the  $I$ - $V$  graph shown?

9702/11/O/N/10/Q32

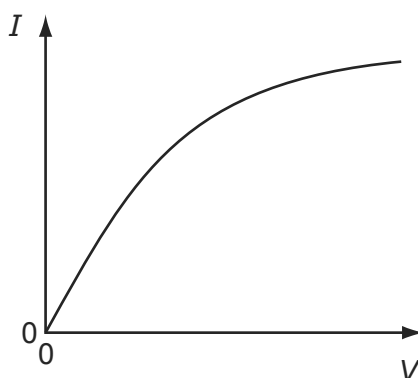

- A** filament lamp
- B** light-dependent resistor
- C** semiconductor diode
- D** thermistor

132 The diagram shows part of a circuit.

9702/11/O/N/10/Q35

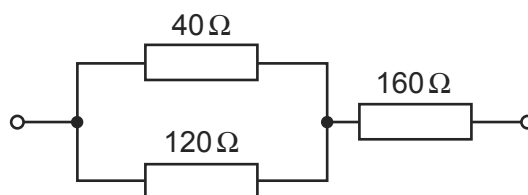

What is the total resistance of the combination of the three resistors?

- A**  $320 \Omega$
- B**  $240 \Omega$
- C**  $190 \Omega$
- D**  $80 \Omega$

133 The diagram shows part of a circuit.

9702/12/O/N/10/Q35

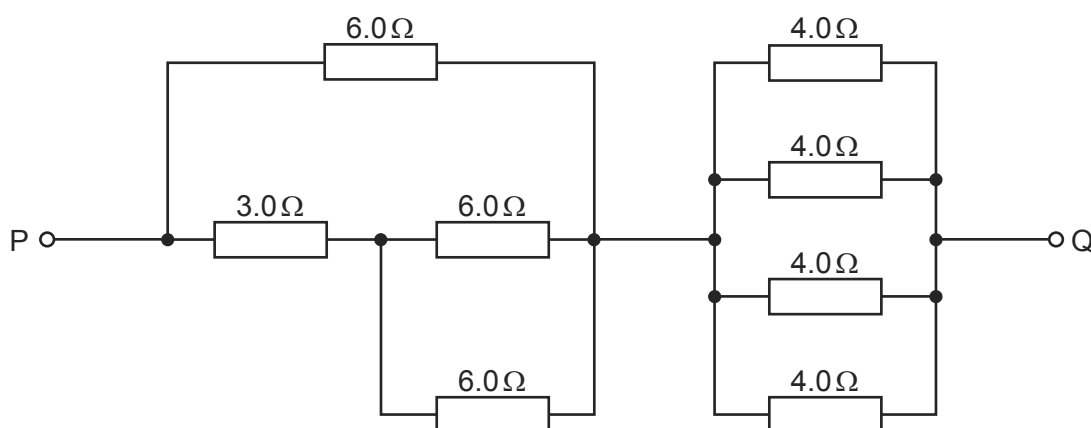

What is the resistance between the points P and Q due to the resistance network?

- A**  $1.3\ \Omega$       **B**  $4.0\ \Omega$       **C**  $10\ \Omega$       **D**  $37\ \Omega$

134 The diagram shows an arrangement of resistors.

9702/11/O/N/10/Q36

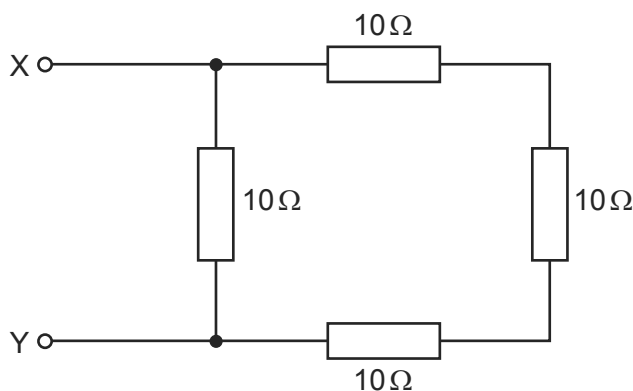

What is the total electrical resistance between X and Y?

- A** less than  $1\ \Omega$   
**B** between  $1\ \Omega$  and  $10\ \Omega$   
**C** between  $10\ \Omega$  and  $30\ \Omega$   
**D**  $40\ \Omega$

135 When there is **no current** in a wire, which statement about the conduction electrons in that wire is correct?

9702/12/O/N/10/Q31

- A** Electrons in the wire are moving totally randomly within the wire.  
**B** Equal numbers of electrons move at the same speed, but in opposite directions, along the wire.  
**C** No current is flowing therefore the electrons in the wire are stationary.  
**D** No current is flowing therefore the electrons in the wire are vibrating around a fixed point.

- 136 In the circuit below, P is a potentiometer of total resistance  $10\ \Omega$  and Q is a fixed resistor of resistance  $10\ \Omega$ . The battery has an e.m.f. of  $4.0\ \text{V}$  and negligible internal resistance. The voltmeter has a very high resistance.

9702/11/O/N/10/Q37

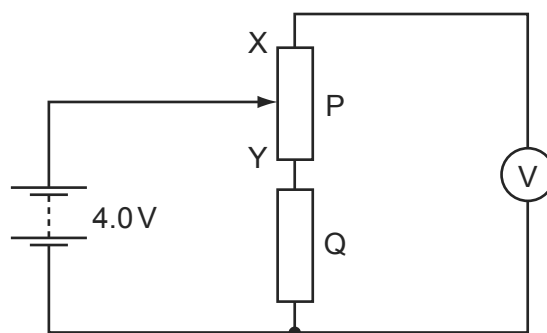

The slider on the potentiometer is moved from X to Y and a graph of voltmeter reading  $V$  is plotted against slider position.

Which graph would be obtained?

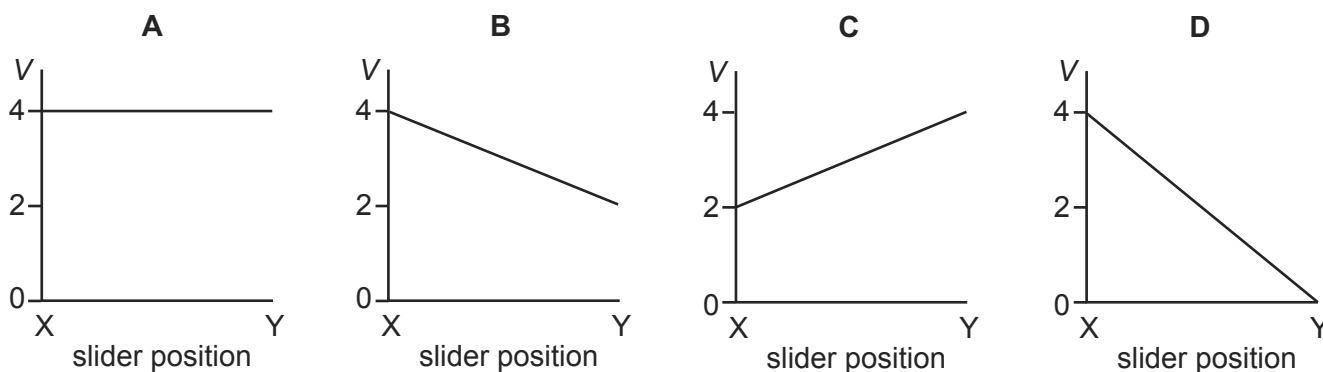

- 137 The current in the circuit shown is  $4.8\ \text{A}$ .

9702/13/O/N/10/Q32

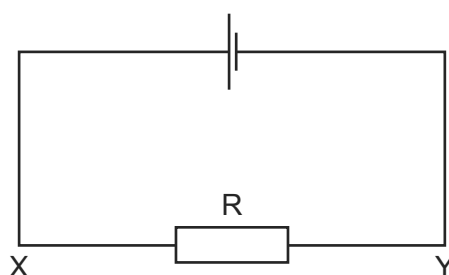

What is the direction of flow and the rate of flow of electrons through the resistor R?

	direction of flow	rate of flow
<b>A</b>	X to Y	$3.0 \times 10^{19}\ \text{s}^{-1}$
<b>B</b>	X to Y	$6.0 \times 10^{18}\ \text{s}^{-1}$
<b>C</b>	Y to X	$3.0 \times 10^{19}\ \text{s}^{-1}$
<b>D</b>	Y to X	$6.0 \times 10^{18}\ \text{s}^{-1}$

138 A high-resistance voltmeter connected across a battery reads 6.0 V.

9702/12/O/N/10/Q32

When the battery is connected in series with a lamp of resistance of  $10\ \Omega$ , the voltmeter reading falls to 5.6 V.

Which statement explains this observation?

- A** The electromotive force (e.m.f.) of the battery decreases because more work is done across its internal resistance.
- B** The e.m.f. of the battery decreases because work is done across the lamp.
- C** The potential difference (p.d.) across the battery decreases because more work is done across its internal resistance.
- D** The p.d. across the battery decreases because work is done across the lamp.

139 A relay is required to operate 800 m from its power supply. The power supply has negligible internal resistance. The relay requires 16.0 V and a current of 0.60 A to operate. 9702/13/O/N/10/Q31

A cable connects the relay to the power supply and two of the wires in the cable are used to supply power to the relay.

The resistance of each of these wires is  $0.0050\ \Omega$  per metre.

What is the minimum output e.m.f. of the power supply?

- A** 16.6 V      **B** 18.4 V      **C** 20.8 V      **D** 29.3 V

140 What is the unit of resistivity?

9702/13/M/J/10/Q30

- A**  $\Omega\text{m}^{-2}$       **B**  $\Omega\text{m}^{-1}$       **C**  $\Omega$       **D**  $\Omega\text{m}$

141 The diagram shows part of a circuit.

9702/13/O/N/10/Q33

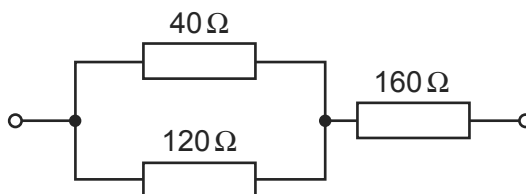

What is the total resistance of the combination of the three resistors?

- A**  $320\ \Omega$       **B**  $240\ \Omega$       **C**  $190\ \Omega$       **D**  $80\ \Omega$

142 A copper wire of cross-sectional area  $2.0\ \text{mm}^2$  carries a current of 10 A.

9702/11/M/J/11/Q31

How many electrons pass through a given cross-section of the wire in one second?

- A**  $1.0 \times 10^1$       **B**  $5.0 \times 10^6$       **C**  $6.3 \times 10^{19}$       **D**  $3.1 \times 10^{25}$

- 143 A battery of e.m.f.  $12\text{ V}$  and internal resistance  $2.0\ \Omega$  is connected in series with an ammeter of negligible resistance and an external resistor. External resistors of various different values are used.

9702/12/O/N/10/Q33

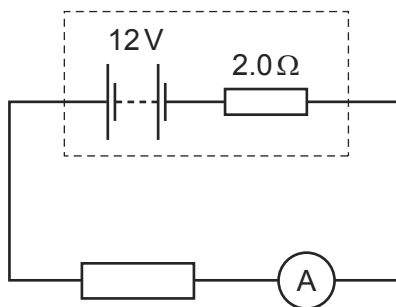

Which combination of current and resistor value is **not** correct?

	current/A	external resistor value/ $\Omega$
<b>A</b>	1.0	10
<b>B</b>	1.2	8
<b>C</b>	1.5	6
<b>D</b>	1.8	4

- 144 A wire PQ is made of three different materials, with resistivities  $\rho$ ,  $2\rho$  and  $3\rho$ . There is a current  $I$  in this composite wire, as shown.

9702/12/O/N/10/Q34

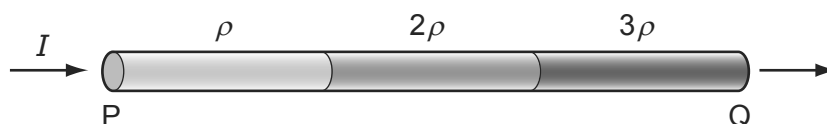

Which graph best shows how the potential  $V$  along the wire varies with distance  $x$  from P?

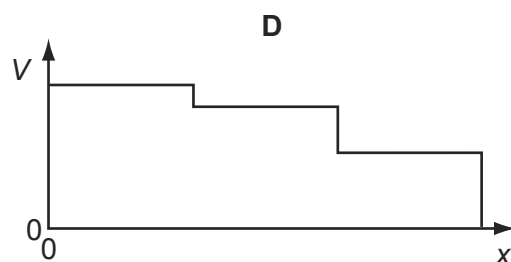
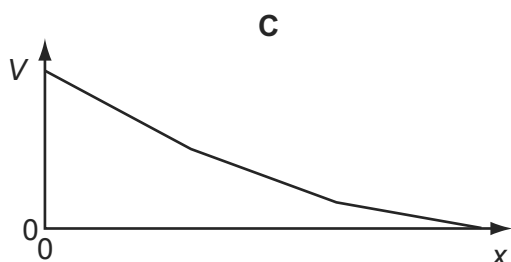
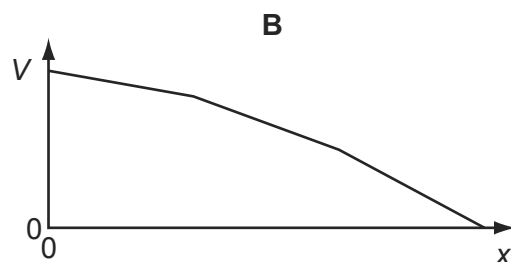
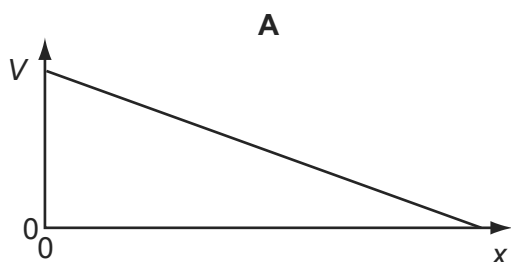

145 The diagram shows a potential divider circuit.

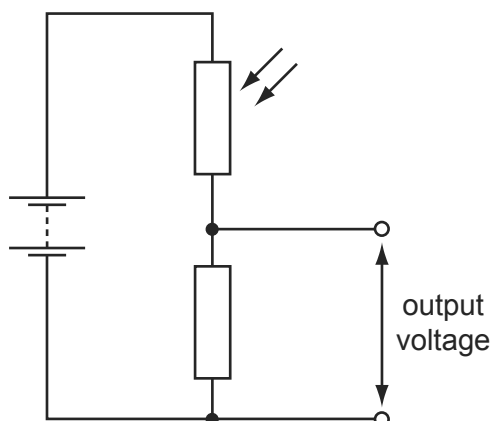

The light level increases.

What is the effect on the resistance of the light-dependent resistor (LDR) and on the output voltage?

	resistance of the LDR	output voltage
<b>A</b>	decreases	decreases
<b>B</b>	decreases	increases
<b>C</b>	increases	decreases
<b>D</b>	increases	increases

146 A relay is required to operate 800 m from its power supply. The power supply has negligible internal resistance. The relay requires 16.0 V and a current of 0.60 A to operate. 9702/11/O/N/10/Q34

A cable connects the relay to the power supply and two of the wires in the cable are used to supply power to the relay.

The resistance of each of these wires is  $0.0050\ \Omega$  per metre.

What is the minimum output e.m.f. of the power supply?

- A** 16.6 V      **B** 18.4 V      **C** 20.8 V      **D** 29.3 V

147 A battery is marked 9.0 V.

What does this mean?

- A** Each coulomb of charge from the battery supplies 9.0 J of electrical energy to the whole circuit.  
**B** The battery supplies 9.0 J to an external circuit for each coulomb of charge.  
**C** The potential difference across any component connected to the battery will be 9.0 V.  
**D** There will always be 9.0 V across the battery terminals.

- 148 Three resistors, with resistances  $R_1$ ,  $R_2$  and  $R_3$ , are connected in series and are found to have a combined resistance of  $500\ \Omega$ . When connected in parallel, the combined resistance is found to be  $50\ \Omega$ .

9702/12/O/N/10/Q37

Which values will correspond to these results?

	$R_1/\Omega$	$R_2/\Omega$	$R_3/\Omega$
<b>A</b>	160	160	80
<b>B</b>	200	200	100
<b>C</b>	225	225	50
<b>D</b>	230	230	40

- 149 A copper wire is cylindrical and has resistance  $R$ .

9702/13/O/N/10/Q34

What will be the resistance of a copper wire of twice the length and twice the radius?

- A**  $\frac{R}{4}$       **B**  $\frac{R}{2}$       **C**  $R$       **D**  $2R$

- 150 In the circuit below, P is a potentiometer of total resistance  $10\ \Omega$  and Q is a fixed resistor of resistance  $10\ \Omega$ . The battery has an e.m.f. of  $4.0\ \text{V}$  and negligible internal resistance. The voltmeter has a very high resistance.

9702/13/O/N/10/Q35

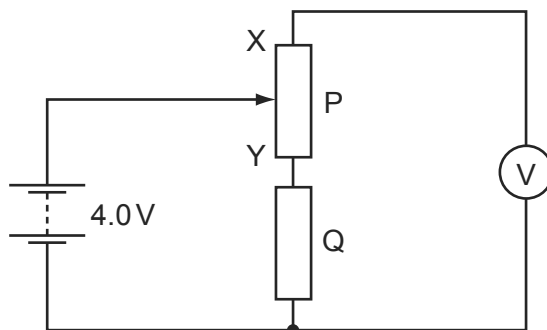

The slider on the potentiometer is moved from X to Y and a graph of voltmeter reading  $V$  is plotted against slider position.

Which graph would be obtained?

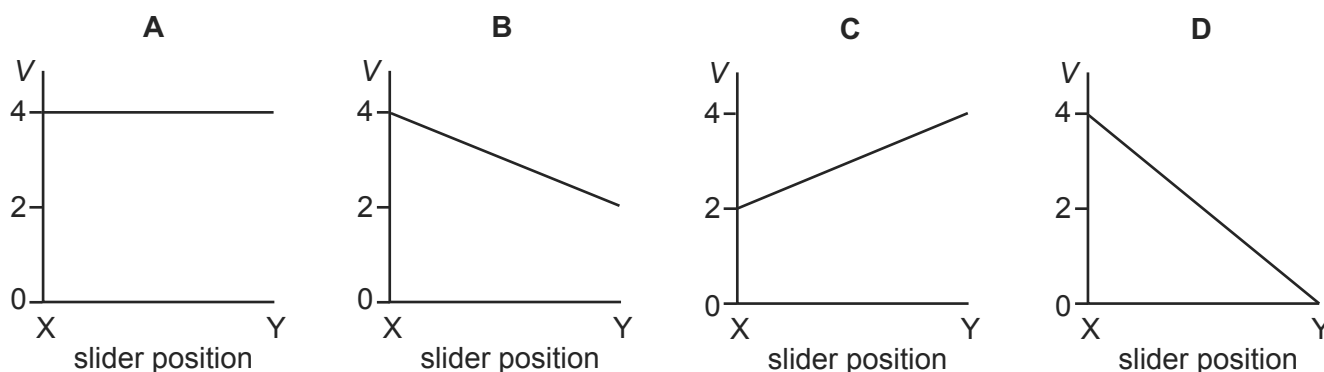

151 Which component has the  $I$ - $V$  graph shown?

9702/13/O/N/10/Q36

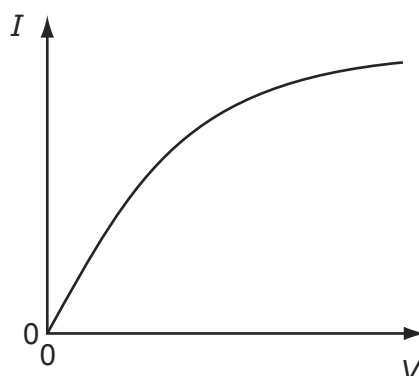

- A filament lamp
- B light-dependent resistor
- C semiconductor diode
- D thermistor

152 The diagram shows an arrangement of resistors.

9702/13/O/N/10/Q37

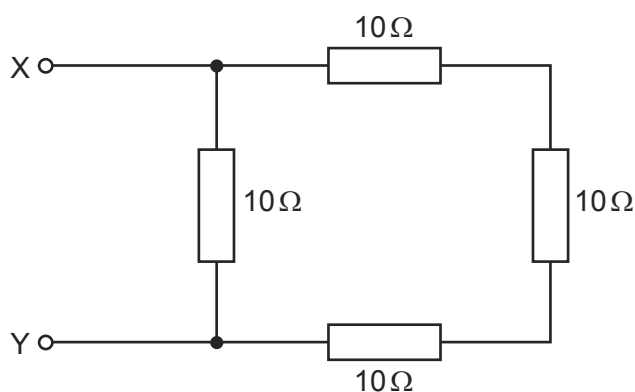

What is the total electrical resistance between X and Y?

- A less than  $1\ \Omega$
- B between  $1\ \Omega$  and  $10\ \Omega$
- C between  $10\ \Omega$  and  $30\ \Omega$
- D  $40\ \Omega$

153 What describes the electric potential difference between two points in a wire that carries a current?

9702/12/M/J/11/Q32

- A the force required to move a unit positive charge between the points
- B the ratio of the energy dissipated between the points to the current
- C the ratio of the power dissipated between the points to the current
- D the ratio of the power dissipated between the points to the charge moved



- 154 The graphs show possible current-voltage ( $I$ - $V$ ) relationships for a filament lamp and for a semiconductor diode.

9702/11/M/J/11/Q33

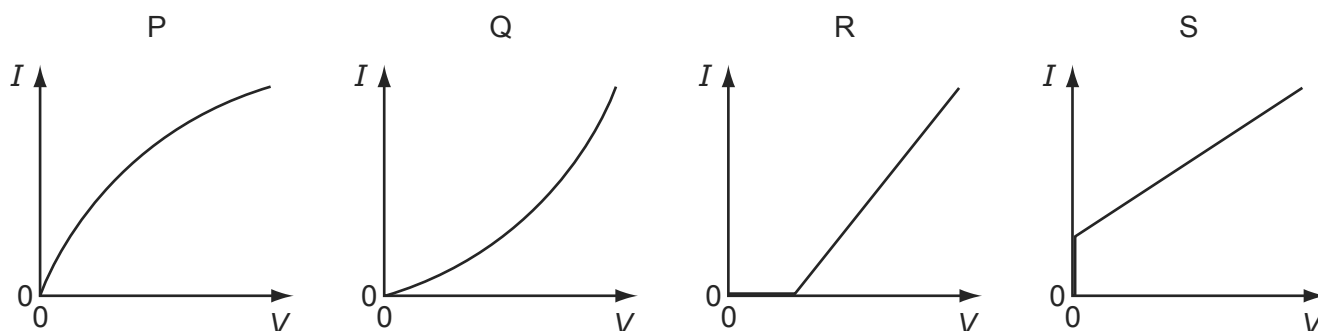

Which row best specifies the correct  $I$ - $V$  graphs for the lamp and the diode?

	filament lamp	semiconductor diode
<b>A</b>	P	R
<b>B</b>	P	S
<b>C</b>	Q	R
<b>D</b>	Q	S

- 155 In the circuit shown,  $XY$  is a length  $L$  of uniform resistance wire.  $R_1$  and  $R_2$  are unknown resistors.  $J$  is a sliding contact that joins the junction of  $R_1$  and  $R_2$  to points on  $XY$  through a small signal lamp  $S$ .

9702/11/M/J/11/Q37

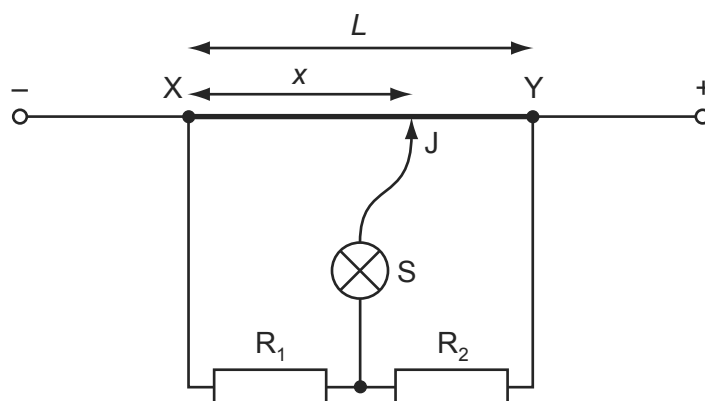

To determine the ratio  $\frac{V_1}{V_2}$  of the potential differences across  $R_1$  and  $R_2$ , a point is found on  $XY$  at which the lamp is off. This point is at a distance  $x$  from  $X$ .

What is the value of the ratio  $\frac{V_1}{V_2}$ ?

- A**  $\frac{L}{x}$       **B**  $\frac{x}{L}$       **C**  $\frac{L-x}{x}$       **D**  $\frac{x}{L-x}$

- 156 The diagram shows part of a current-carrying circuit. The ammeter has negligible internal resistance.

9702/11/M/J/11/Q35

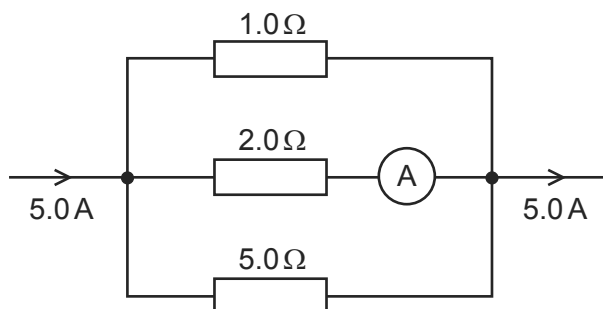

What is the reading on the ammeter?

- A** 0.7 A      **B** 1.3 A      **C** 1.5 A      **D** 1.7 A
- 157 Four resistors of equal value are connected as shown.

9702/11/M/J/11/Q36

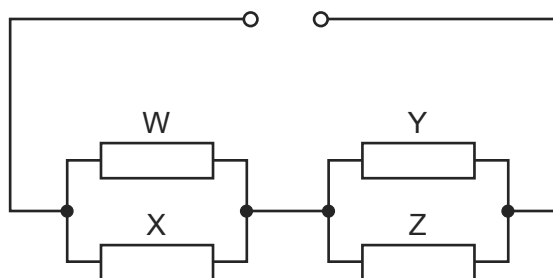

How will the powers to the resistors change when resistor *W* is removed?

- A** The powers to *X*, *Y* and *Z* will all increase.  
**B** The power to *X* will decrease and the powers to *Y* and *Z* will increase.  
**C** The power to *X* will increase and the powers to *Y* and *Z* will decrease.  
**D** The power to *X* will increase and the powers to *Y* and *Z* will remain unaltered.
- 158 Which graph best represents the way in which the current *I* through a thermistor depends upon the potential difference *V* across it?

9702/12/M/J/11/Q35

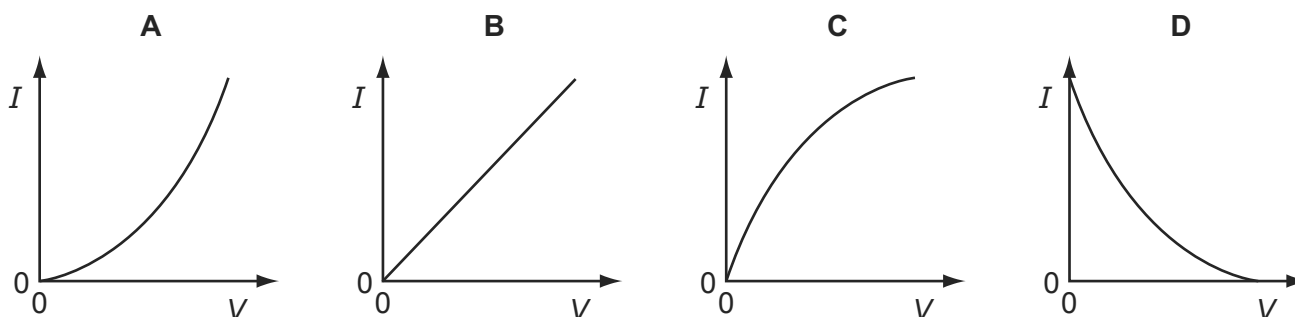

- 159 A cylindrical piece of a soft, electrically-conducting material has resistance  $R$ . It is rolled out so that its length is doubled but its volume stays constant. 9702/12/M/J/11/Q33

What is its new resistance?

- A**  $\frac{R}{2}$                       **B**  $R$                       **C**  $2R$                       **D**  $4R$

- 160 A source of electromotive force (e.m.f.)  $E$  has a constant internal resistance  $r$  and is connected to an external variable resistor of resistance  $R$ . 9702/12/M/J/11/Q34

As  $R$  is increased from a value below  $r$  to a value above  $r$ , which statement is correct?

- A** The terminal potential difference remains constant.  
**B** The current in the circuit increases.  
**C** The e.m.f. of the source increases.  
**D** The largest output power is obtained when  $R$  reaches  $r$ .

- 161 Safety on railways is increased by using several electrical switches. 9702/12/M/J/11/Q36

In the diagram, switches P, Q, R, S and T control the current through a green lamp.

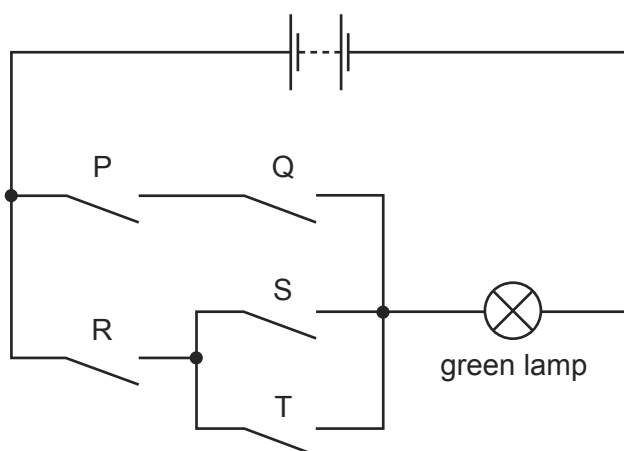

Which row does **not** allow the green lamp to light?

	P	Q	R	S	T
<b>A</b>	closed	closed	closed	open	closed
<b>B</b>	closed	open	closed	closed	open
<b>C</b>	closed	open	open	closed	closed
<b>D</b>	open	open	closed	open	closed

162 The resistance of a metal cube is measured by placing it between two parallel plates, as shown.

9702/11/M/J/11/Q34

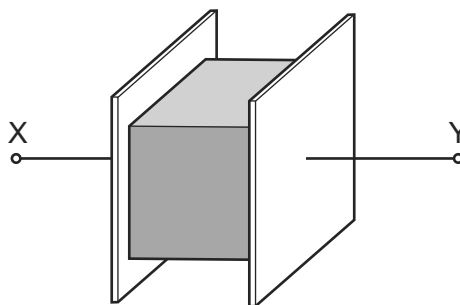

The cube has volume  $V$  and is made of a material with resistivity  $\rho$ . The connections to the cube have negligible resistance.

Which expression gives the electrical resistance of the metal cube between X and Y?

- A**  $\rho V^{\frac{1}{3}}$       **B**  $\rho V^{\frac{2}{3}}$       **C**  $\frac{\rho}{V^{\frac{1}{3}}}$       **D**  $\frac{\rho}{V^{\frac{2}{3}}}$

163 A battery is marked 9.0V.

9702/13/M/J/11/Q31

What does this mean?

- A** Each coulomb of charge from the battery supplies 9.0J of electrical energy to the whole circuit.  
**B** The battery supplies 9.0J to an external circuit for each coulomb of charge.  
**C** The potential difference across any component connected to the battery will be 9.0V.  
**D** There will always be 9.0V across the battery terminals.

164 Four resistors of equal value are connected as shown.

9702/13/M/J/11/Q33

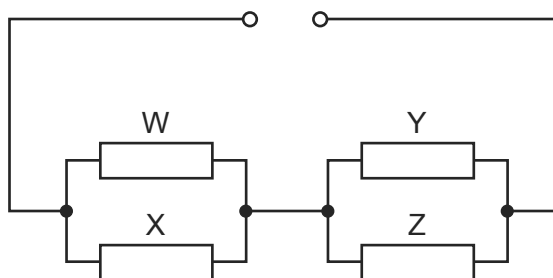

How will the powers to the resistors change when resistor W is removed?

- A** The powers to X, Y and Z will all increase.  
**B** The power to X will decrease and the powers to Y and Z will increase.  
**C** The power to X will increase and the powers to Y and Z will decrease.  
**D** The power to X will increase and the powers to Y and Z will remain unaltered.

- 165 The diagram shows a fixed resistor and a light-dependent resistor (LDR) in series with a constant low-voltage supply.

9702/12/M/J/11/Q37

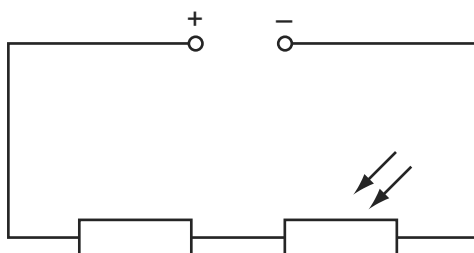

When the LDR is in the dark, the fixed resistor and the LDR have the same value of resistance.

Light is shone on the LDR.

What happens to the potential differences across the two components?

	p.d. across resistor	p.d. across LDR
<b>A</b>	decreased	increased
<b>B</b>	increased	decreased
<b>C</b>	no change	increased
<b>D</b>	no change	decreased

- 166 The graphs show possible current-voltage ( $I$ - $V$ ) relationships for a filament lamp and for a semiconductor diode.

9702/13/M/J/11/Q34

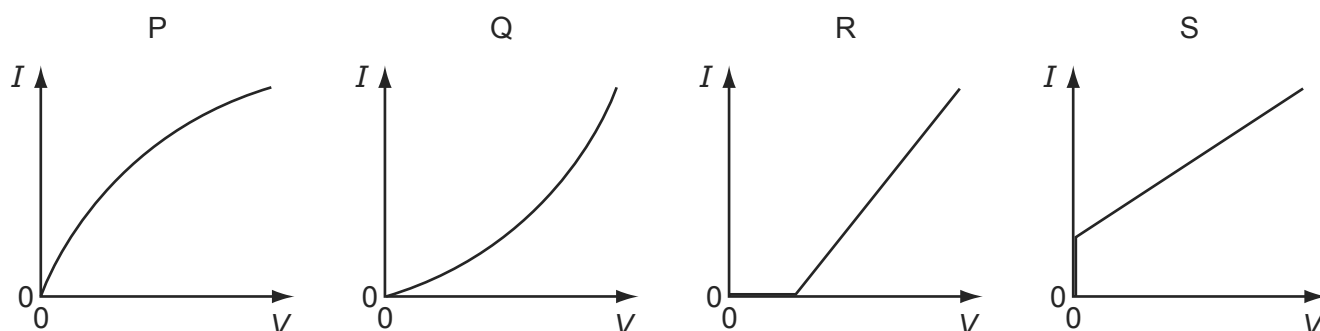

Which row best specifies the correct  $I$ - $V$  graphs for the lamp and the diode?

	filament lamp	semiconductor diode
<b>A</b>	P	R
<b>B</b>	P	S
<b>C</b>	Q	R
<b>D</b>	Q	S

167 The diagram shows a d.c. circuit.

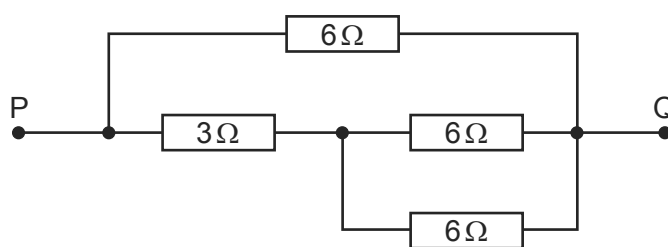

What is the resistance between the points P and Q due to the resistance network?

- A**  $0.47\ \Omega$       **B**  $2.1\ \Omega$       **C**  $3.0\ \Omega$       **D**  $21\ \Omega$

168 A copper wire of cross-sectional area  $2.0\ \text{mm}^2$  carries a current of 10 A.

9702/13/M/J/11/Q32

How many electrons pass through a given cross-section of the wire in one second?

- A**  $1.0 \times 10^1$       **B**  $5.0 \times 10^6$       **C**  $6.3 \times 10^{19}$       **D**  $3.1 \times 10^{25}$

169 The resistance of a metal cube is measured by placing it between two parallel plates, as shown.

9702/13/M/J/11/Q35

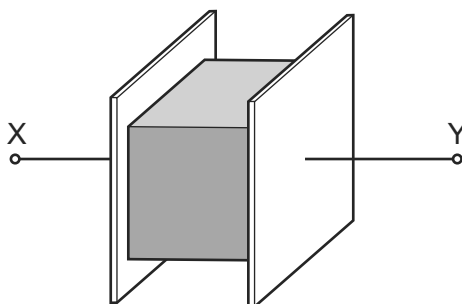

The cube has volume  $V$  and is made of a material with resistivity  $\rho$ . The connections to the cube have negligible resistance.

Which expression gives the electrical resistance of the metal cube between X and Y?

- A**  $\rho V^{\frac{1}{3}}$       **B**  $\rho V^{\frac{2}{3}}$       **C**  $\frac{\rho}{V^{\frac{1}{3}}}$       **D**  $\frac{\rho}{V^{\frac{2}{3}}}$

170 Which statement is **not** valid?

9702/11/O/N/11/Q35

- A** Current is the speed of the charged particles that carry it.  
**B** Electromotive force (e.m.f.) is the energy converted to electrical energy from other forms, per unit charge.  
**C** The potential difference (p.d.) between two points is the work done in moving unit charge from one point to the other.  
**D** The resistance between two points is the p.d. between the two points, per unit current.

- 171 In the circuit shown, XY is a length  $L$  of uniform resistance wire.  $R_1$  and  $R_2$  are unknown resistors. J is a sliding contact that joins the junction of  $R_1$  and  $R_2$  to points on XY through a small signal lamp S.

9702/13/M/J/11/Q36

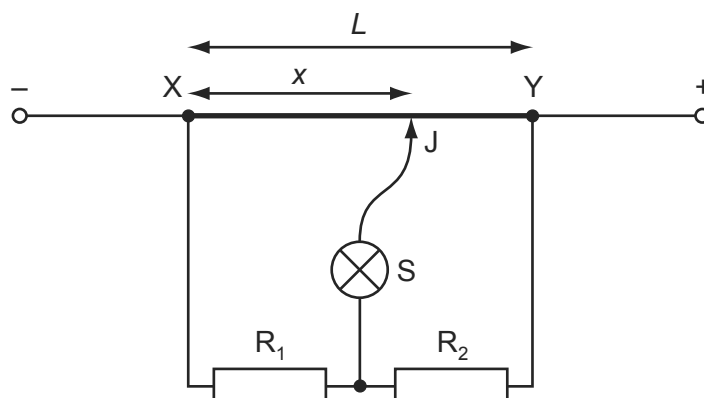

To determine the ratio  $\frac{V_1}{V_2}$  of the potential differences across  $R_1$  and  $R_2$ , a point is found on XY at which the lamp is off. This point is at a distance  $x$  from X.

What is the value of the ratio  $\frac{V_1}{V_2}$ ?

- A  $\frac{L}{x}$       B  $\frac{x}{L}$       C  $\frac{L-x}{x}$       D  $\frac{x}{L-x}$

- 172 A cell, two resistors of equal resistance and an ammeter are used to construct four circuits. The resistors are the only parts of the circuits that have resistance.

9702/11/O/N/11/Q37

In which circuit will the ammeter show the greatest reading?

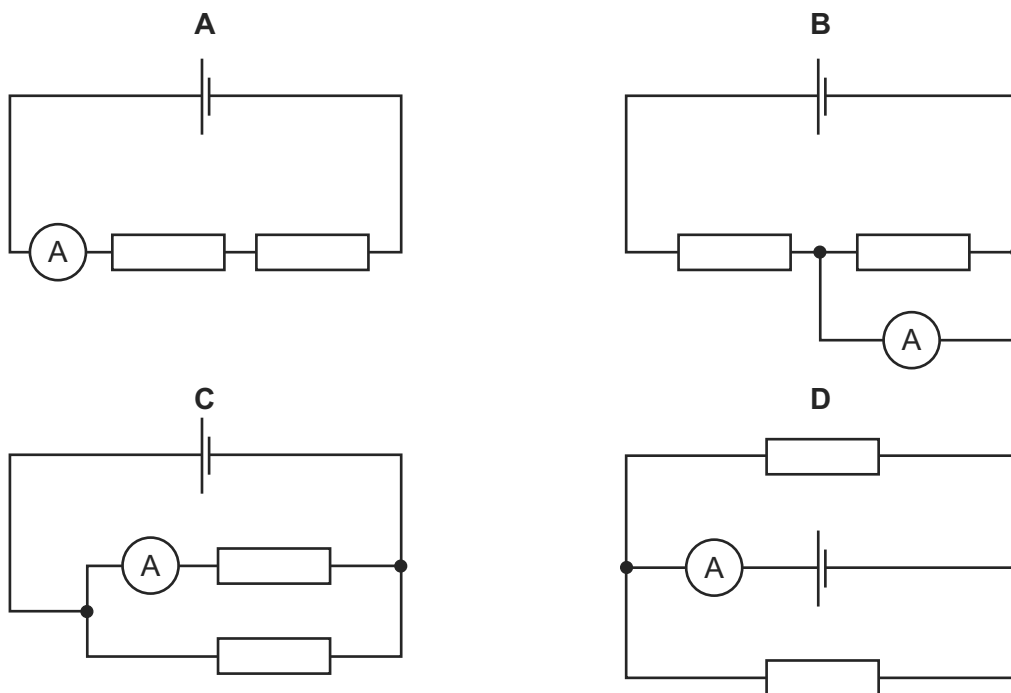

- 173 A cell of e.m.f.  $E$  and internal resistance  $r$  is connected in series with a switch  $S$  and an external resistor of resistance  $R$ .

9702/11/O/N/11/Q36

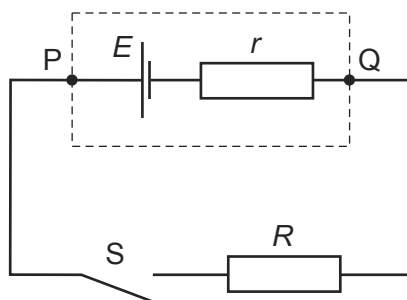

The p.d. between  $P$  and  $Q$  is  $V$ .

When  $S$  is closed,

- A**  $V$  decreases because there is a p.d. across  $R$ .
- B**  $V$  decreases because there is a p.d. across  $r$ .
- C**  $V$  remains the same because the decrease of p.d. across  $r$  is balanced by the increase of p.d. across  $R$ .
- D**  $V$  remains the same because the sum of the p.d.s across  $r$  and  $R$  is still equal to  $E$ .

- 174 Which of the equations that link some of the following terms is correct?

9702/11/O/N/11/Q34

potential difference (p.d.)	$V$
current	$I$
resistance	$R$
charge	$Q$
energy	$E$
power	$P$
time	$t$

- A**  $P = \frac{Q^2 R}{t}$
- B**  $ER^2 = V^2 t$
- C**  $\frac{VI}{P} = t$
- D**  $PQ = EI$



175 The diagram shows a potential divider circuit designed to provide a variable output p.d.

9702/11/O/N/11/Q39

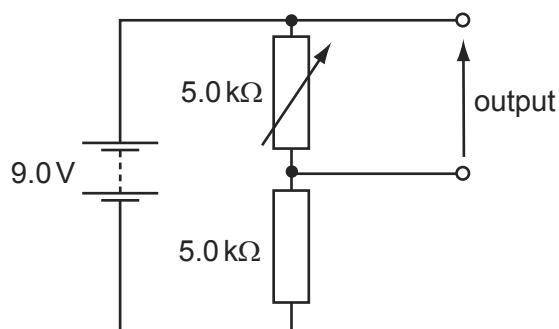

Which row gives the available range of output p.d.?

	maximum output	minimum output
<b>A</b>	3.0V	0
<b>B</b>	4.5V	0
<b>C</b>	9.0V	0
<b>D</b>	9.0V	4.5V

176 The diagram shows part of a current-carrying circuit. The ammeter has negligible internal resistance.

9702/13/M/J/11/Q37

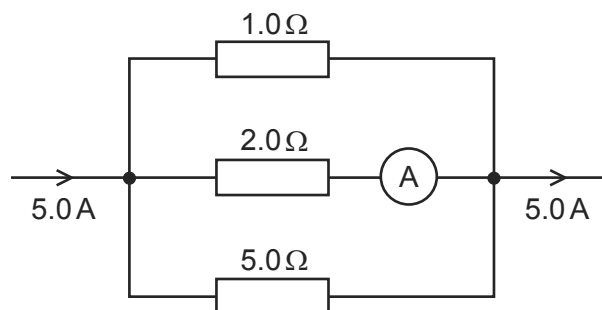

What is the reading on the ammeter?

- A** 0.7 A      **B** 1.3 A      **C** 1.5 A      **D** 1.7 A

177 There is a current of 10 mA in a conductor for half an hour.

9702/11/M/J/12/Q33

How much charge passes a point in the conductor in this time?

- A** 0.3 C      **B** 5 C      **C** 18 C      **D** 300 C

178 A charge of 8.0 C passes through a resistor of resistance  $30 \Omega$  at a constant rate in a time of 20 s.

9702/12/O/N/11/Q32

What is the potential difference across the resistor?

- A** 0.40 V      **B** 5.3 V      **C** 12 V      **D** 75 V

179 Three resistors of resistance  $R$ ,  $2R$  and  $3R$  are connected in parallel.

9702/11/O/N/11/Q38

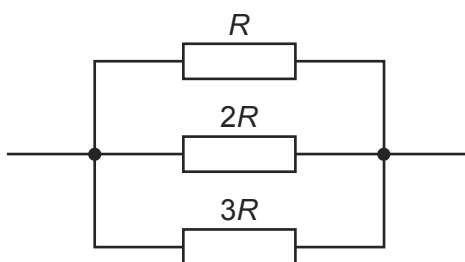

Using  $I$  to represent the current through the resistor of resistance  $R$ , which row represents the relationships between the currents through the resistors?

	resistor resistance		
	$R$	$2R$	$3R$
<b>A</b>	$I$	$\frac{1}{3}I$	$\frac{1}{2}I$
<b>B</b>	$I$	$\frac{1}{2}I$	$\frac{1}{3}I$
<b>C</b>	$I$	$\frac{2}{3}I$	$\frac{1}{3}I$
<b>D</b>	$I$	$2I$	$3I$

180 An iron wire has length 8.0 m and diameter 0.50 mm. The wire has resistance  $R$ .

9702/11/M/J/12/Q34

A second iron wire has length 2.0 m and diameter 1.0 mm.

What is the resistance of the second wire?

- A**  $\frac{R}{16}$       **B**  $\frac{R}{8}$       **C**  $\frac{R}{2}$       **D**  $R$

181 Two electrically-conducting cylinders X and Y are made from the same material.

9702/12/O/N/11/Q34

Their dimensions are as shown.

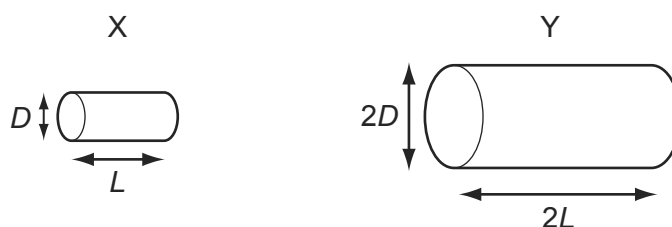

The resistance of each cylinder is measured between its ends.

What is the ratio  $\frac{\text{resistance of X}}{\text{resistance of Y}}$ ?

- A**  $\frac{2}{1}$       **B**  $\frac{1}{1}$       **C**  $\frac{1}{2}$       **D**  $\frac{1}{4}$

182 The graph shows the variation with potential difference (p.d.) of the current in a lamp filament.

9702/12/O/N/11/Q33

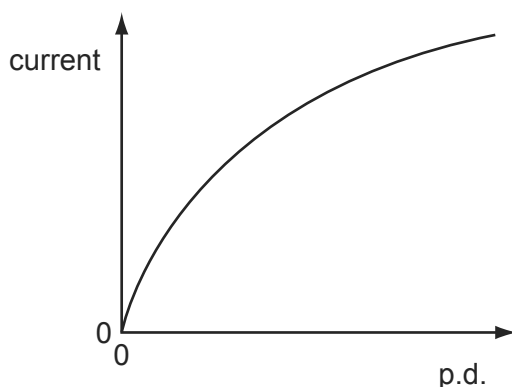

Which statement explains the shape of this graph?

- A** As the filament temperature rises, electrons can pass more easily through the filament.
- B** It takes time for the filament to reach its working temperature.
- C** The power output of the filament is proportional to the square of the current in it.
- D** The resistance of the filament increases with a rise in temperature.

183 A power supply of electromotive force (e.m.f.) 12V and internal resistance  $2\Omega$  is connected in series with a load resistor. The value of the load resistor is varied from  $0.5\Omega$  to  $4\Omega$ .

Which graph shows how the power  $P$  dissipated in the load resistor varies with the resistance of the load resistor?

9702/12/O/N/11/Q35

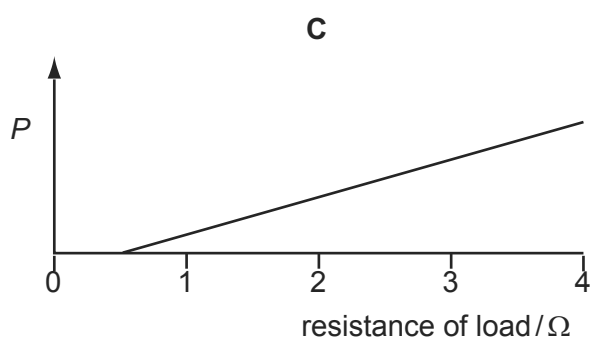
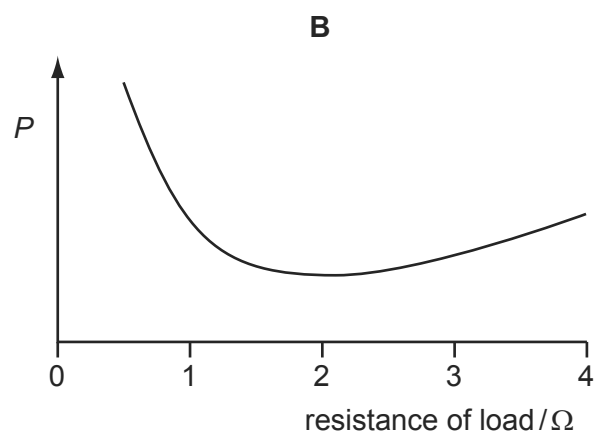

- 184 The diagram shows a potential divider circuit which, by adjustment of the contact X, can be used to provide a variable potential difference between the terminals P and Q. 9702/12/O/N/11/Q37

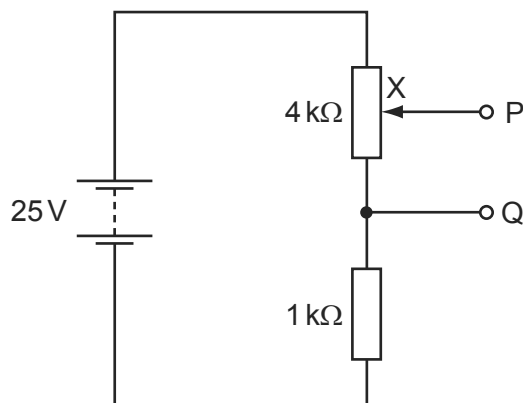

What are the limits of this potential difference?

- A** 0 and 5V      **B** 0 and 20V      **C** 0 and 25V      **D** 5V and 25V
- 185 Each of Kirchhoff's laws is linked to the conservation of a physical quantity. 9702/12/O/N/11/Q36

Which physical quantities are assumed to be conserved in the formulation of Kirchhoff's first law and of Kirchhoff's second law?

	Kirchhoff's first law	Kirchhoff's second law
<b>A</b>	energy	charge
<b>B</b>	energy	momentum
<b>C</b>	charge	energy
<b>D</b>	momentum	energy

- 186 Which statement about electrical resistivity is correct? 9702/11/O/N/11/Q33

- A** The resistivity of a material is numerically equal to the resistance in ohms of a cube of that material, the cube being of side length one metre and the resistance being measured between opposite faces.
- B** The resistivity of a material is numerically equal to the resistance in ohms of a one metre length of wire of that material, the area of cross-section of the wire being one square millimetre and the resistance being measured between the ends of the wire.
- C** The resistivity of a material is proportional to the cross-sectional area of the sample of the material used in the measurement.
- D** The resistivity of a material is proportional to the length of the sample of the material used in the measurement.

187 A constant 60 V d.c. supply is connected across two resistors of resistance 400 k $\Omega$  and 200 k $\Omega$ .

9702/12/O/N/11/Q38

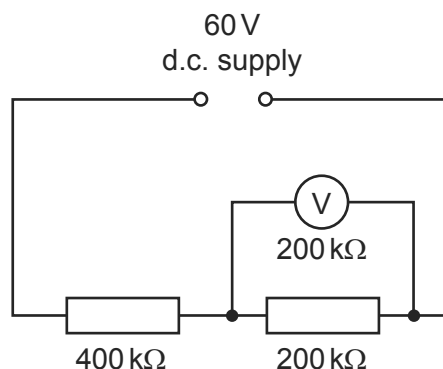

What is the reading on a voltmeter, also of resistance 200 k $\Omega$ , when connected across the 200 k $\Omega$  resistor as shown in the diagram?

- A** 12 V                      **B** 15 V                      **C** 20 V                      **D** 30 V

188 Which statement is **not** valid?

9702/13/O/N/11/Q34

- A** Current is the speed of the charged particles that carry it.  
**B** Electromotive force (e.m.f.) is the energy converted to electrical energy from other forms, per unit charge.  
**C** The potential difference (p.d.) between two points is the work done in moving unit charge from one point to the other.  
**D** The resistance between two points is the p.d. between the two points, per unit current.

189 The circuit below has a current  $I$  in the resistor R.

9702/11/M/J/12/Q38

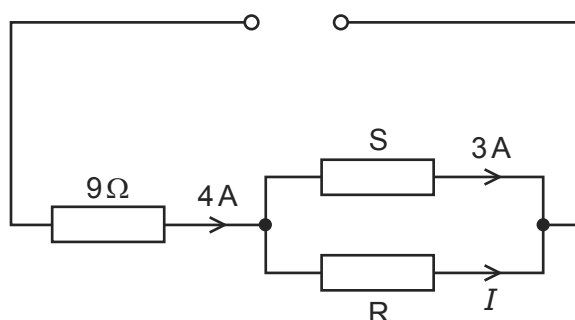

What must be known in order to determine the value of  $I$ ?

- A** e.m.f. of the power supply  
**B** resistance of resistor S  
**C** Kirchhoff's first law  
**D** Kirchhoff's second law

- 190 A cell, two resistors of equal resistance and an ammeter are used to construct four circuits. The resistors are the only parts of the circuits that have resistance. 9702/13/O/N/11/Q36

In which circuit will the ammeter show the greatest reading?

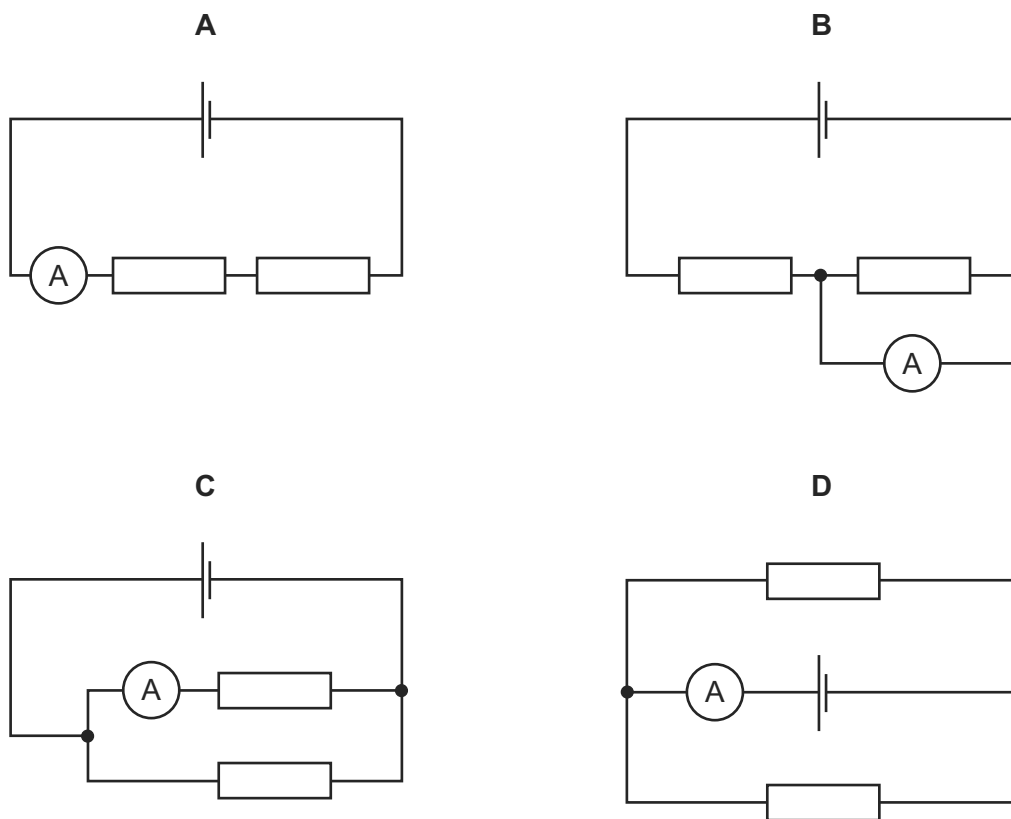

- 191 Three resistors of resistance  $R$ ,  $2R$  and  $3R$  are connected in parallel. 9702/13/O/N/11/Q37

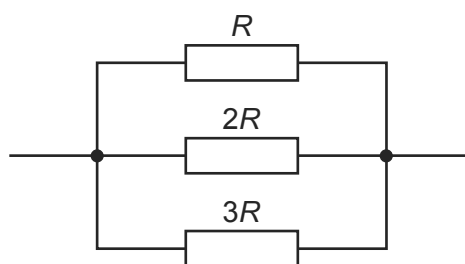

Using  $I$  to represent the current through the resistor of resistance  $R$ , which row represents the relationships between the currents through the resistors?

	resistor resistance		
	$R$	$2R$	$3R$
<b>A</b>	$I$	$\frac{1}{3}I$	$\frac{1}{2}I$
<b>B</b>	$I$	$\frac{1}{2}I$	$\frac{1}{3}I$
<b>C</b>	$I$	$\frac{2}{3}I$	$\frac{1}{3}I$
<b>D</b>	$I$	$2I$	$3I$

- 192 A cell of e.m.f.  $E$  and internal resistance  $r$  is connected in series with a switch  $S$  and an external resistor of resistance  $R$ .

9702/13/O/N/11/Q38

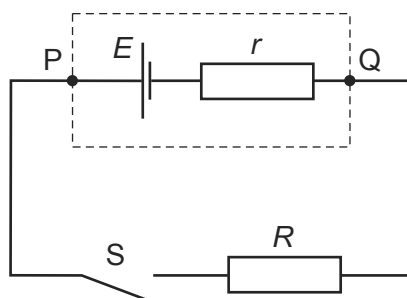

The p.d. between P and Q is  $V$ .

When  $S$  is closed,

- A**  $V$  decreases because there is a p.d. across  $R$ .
- B**  $V$  decreases because there is a p.d. across  $r$ .
- C**  $V$  remains the same because the decrease of p.d. across  $r$  is balanced by the increase of p.d. across  $R$ .
- D**  $V$  remains the same because the sum of the p.d.s across  $r$  and  $R$  is still equal to  $E$ .
- 193 A potential divider consists of a light-dependent resistor (LDR) in series with a variable resistor of resistance  $R$ . The resistance of the LDR decreases when the light level increases. The variable resistor can be set at either high resistance or low resistance.

9702/11/M/J/12/Q37

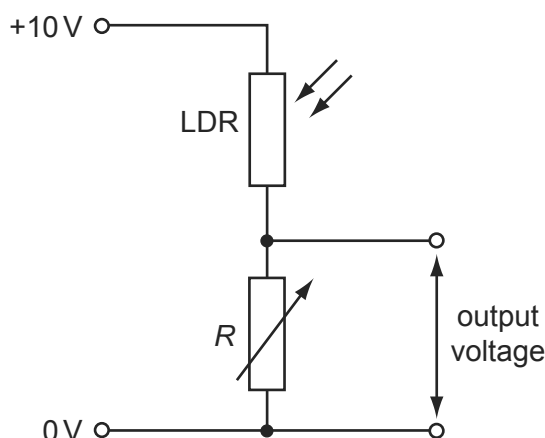

Which situation gives the largest output voltage?

	light level at LDR	$R$
<b>A</b>	high	high
<b>B</b>	high	low
<b>C</b>	low	high
<b>D</b>	low	low

194 The diagram shows a potential divider circuit designed to provide a variable output p.d.

9702/13/O/N/11/Q40

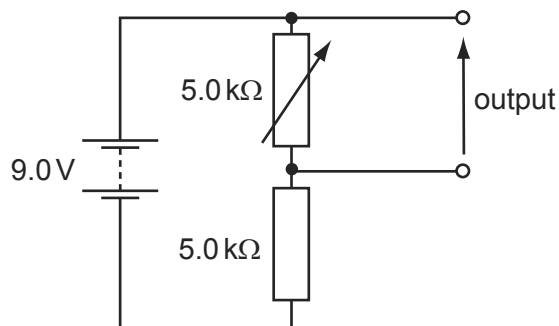

Which row gives the available range of output p.d.?

	maximum output	minimum output
<b>A</b>	3.0V	0
<b>B</b>	4.5V	0
<b>C</b>	9.0V	0
<b>D</b>	9.0V	4.5V

195 Two copper wires of the same length but different diameters carry the same current. 9702/12/M/J/12/Q33

Which statement about the flow of charged particles through the wires is correct?

- A** Charged particles are provided by the power supply. Therefore the speed at which they travel depends only on the voltage of the supply.
- B** The charged particles in both wires move with the same average speed because the current in both wires is the same.
- C** The charged particles move faster through the wire with the larger diameter because there is a greater volume through which to flow.
- D** The charged particles move faster through the wire with the smaller diameter because it has a larger potential difference applied to it.

196 A power cable X has resistance  $R$  and carries current  $I$ .

9702/12/M/J/12/Q34

A second cable Y has resistance  $2R$  and carries current  $\frac{1}{2}I$ .

What is the ratio  $\frac{\text{power dissipated in Y}}{\text{power dissipated in X}}$ ?

- A**  $\frac{1}{4}$
- B**  $\frac{1}{2}$
- C** 2
- D** 4



197 In the circuit below, the ammeter reading is  $I$  and the voltmeter reading is  $V$ .

9702/11/M/J/12/Q36

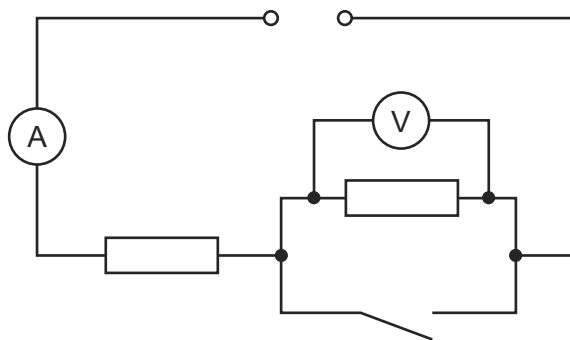

When the switch is closed, which row describes what happens to  $I$  and  $V$ ?

	$I$	$V$
<b>A</b>	decreases	decreases to zero
<b>B</b>	increases	decreases to zero
<b>C</b>	increases	stays the same
<b>D</b>	stays the same	increases

198 The diagram shows a circuit with four voltmeter readings  $V$ ,  $V_1$ ,  $V_2$  and  $V_3$ .

9702/12/M/J/12/Q35

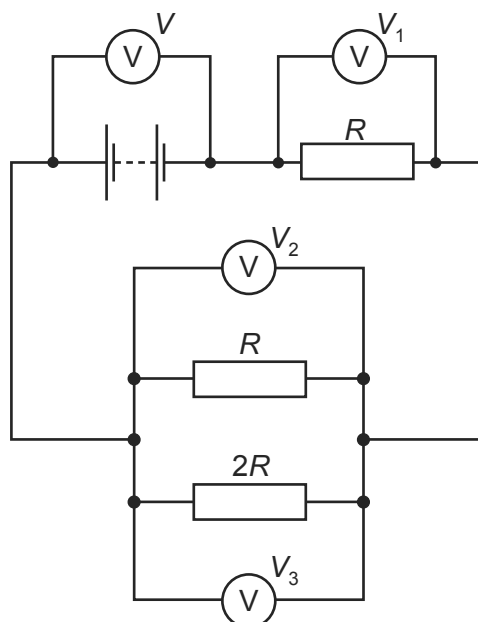

Which equation relating the voltmeter readings must be true?

- A**  $V = V_1 + V_2 + V_3$
- B**  $V + V_1 = V_2 + V_3$
- C**  $V_3 = 2(V_2)$
- D**  $V - V_1 = V_3$

199 Which statement about electrical resistivity is correct?

9702/13/O/N/11/Q35

- A** The resistivity of a material is numerically equal to the resistance in ohms of a cube of that material, the cube being of side length one metre and the resistance being measured between opposite faces.
- B** The resistivity of a material is numerically equal to the resistance in ohms of a one metre length of wire of that material, the area of cross-section of the wire being one square millimetre and the resistance being measured between the ends of the wire.
- C** The resistivity of a material is proportional to the cross-sectional area of the sample of the material used in the measurement.
- D** The resistivity of a material is proportional to the length of the sample of the material used in the measurement.

200 The diagram shows a simple circuit.

9702/11/M/J/12/Q35

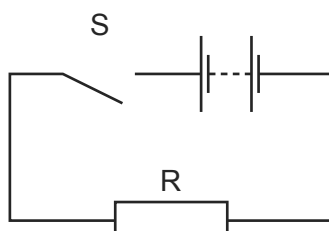

Which statement is correct?

- A** When switch S is closed, the electromotive force (e.m.f.) of the battery falls because work is done against the internal resistance of the battery.
- B** When switch S is closed, the e.m.f. of the battery falls because work is done against the resistance R.
- C** When switch S is closed, the potential difference across the battery falls because work is done against the internal resistance of the battery.
- D** When switch S is closed, the potential difference across the battery falls because work is done against the resistance R.

201 An iron wire has length 8.0 m and diameter 0.50 mm. The wire has resistance  $R$ .

9702/13/M/J/12/Q32

A second iron wire has length 2.0 m and diameter 1.0 mm.

What is the resistance of the second wire?

- A**  $\frac{R}{16}$
- B**  $\frac{R}{8}$
- C**  $\frac{R}{2}$
- D**  $R$

202 There is a current of 10 mA in a conductor for half an hour.

9702/13/M/J/12/Q34

How much charge passes a point in the conductor in this time?

- A** 0.3 C
- B** 5 C
- C** 18 C
- D** 300 C

203 Which of the equations that link some of the following terms is correct?

9702/13/O/N/11/Q39

potential difference (p.d.)	$V$
current	$I$
resistance	$R$
charge	$Q$
energy	$E$
power	$P$
time	$t$

**A**  $P = \frac{Q^2 R}{t}$

**B**  $ER^2 = V^2 t$

**C**  $\frac{VI}{P} = t$

**D**  $PQ = EI$

204 A potential divider consists of a light-dependent resistor (LDR) in series with a variable resistor of resistance  $R$ . The resistance of the LDR decreases when the light level increases. The variable resistor can be set at either high resistance or low resistance.

9702/13/M/J/12/Q38

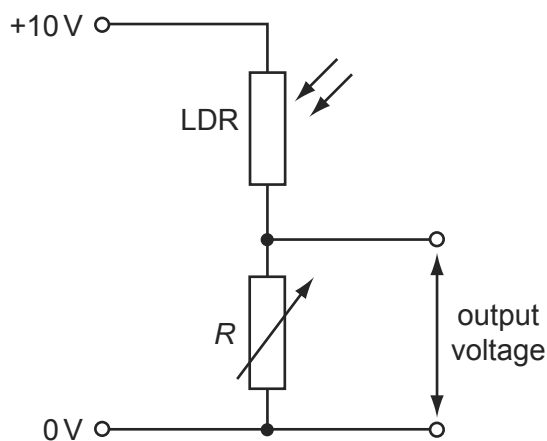

Which situation gives the largest output voltage?

	light level at LDR	$R$
<b>A</b>	high	high
<b>B</b>	high	low
<b>C</b>	low	high
<b>D</b>	low	low

- 205 The diagram shows the circuit for a signal to display a green or a red light. It is controlled by the switch S.

9702/12/M/J/12/Q37

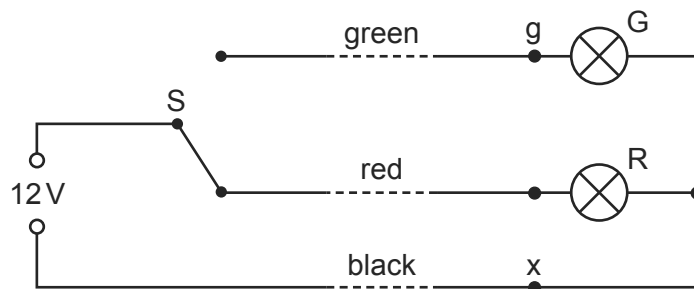

The signal is some way from S to which it is connected by a cable with green, red and black wires. At the signal, the green and red wires are connected to the corresponding lamp and the black wire is connected to a terminal x to provide a common return. The arrangement is shown correctly connected and with the switch set to illuminate the red lamp.

During maintenance, the wires at the signal are disconnected and, when reconnected, the black wire is connected in error to the green lamp (terminal g) instead of terminal x. The red wire is connected correctly to its lamp and connections at S remain as in the diagram.

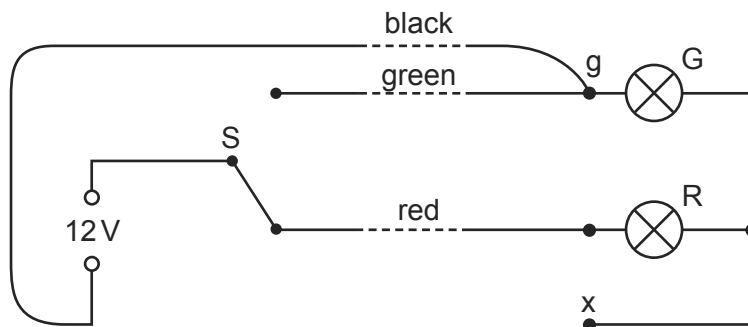

When the system is tested with the switch connection to the red wire, what does the signal show?

- A the green lamp illuminated normally
  - B the red lamp illuminated normally
  - C the red and green lamps both illuminated normally
  - D the red and green lamps both illuminated dimly
- 206 In a fire alarm system, a thermistor T has a resistance of  $2000\Omega$  at room temperature. Its resistance decreases as the temperature increases. The alarm is triggered when the potential difference between X and Y reaches  $4.5\text{V}$ .

9702/11/O/N/12/Q35

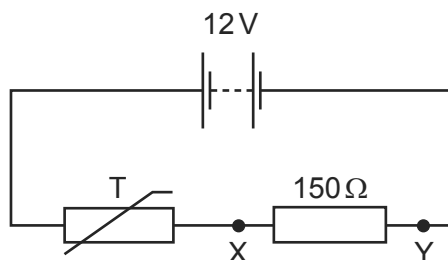

What is the resistance of the thermistor when the alarm is triggered?

- A  $90\Omega$
- B  $150\Omega$
- C  $250\Omega$
- D  $1300\Omega$

207 In the circuit below, the ammeter reading is  $I$  and the voltmeter reading is  $V$ .

9702/13/M/J/12/Q35

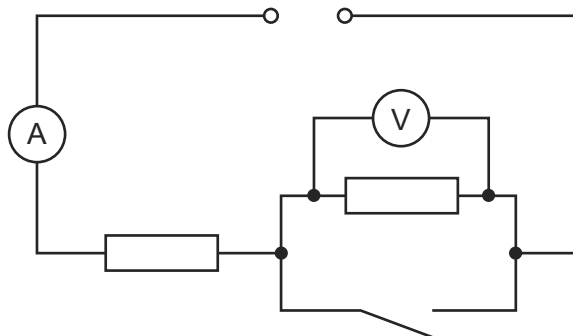

When the switch is closed, which row describes what happens to  $I$  and  $V$ ?

	$I$	$V$
<b>A</b>	decreases	decreases to zero
<b>B</b>	increases	decreases to zero
<b>C</b>	increases	stays the same
<b>D</b>	stays the same	increases

208 A light-dependent resistor (LDR) is connected in series with a resistor  $R$  and a battery.

9702/12/M/J/12/Q36

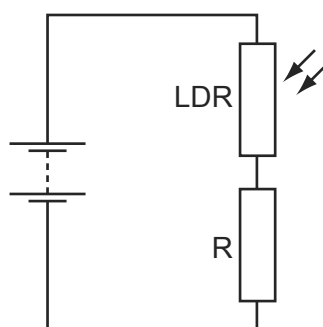

The resistance of the LDR is equal to the resistance of  $R$  when no light falls on the LDR.

When the light intensity falling on the LDR increases, which statement is correct?

- A** The current in  $R$  decreases.
- B** The current in the LDR decreases.
- C** The p.d. across  $R$  decreases.
- D** The p.d. across the LDR decreases.

209 The potential difference between point  $X$  and point  $Y$  in a circuit is  $20\text{V}$ . The time taken for charge carriers to move from  $X$  to  $Y$  is  $15\text{ s}$ . In this time, the energy of the charge carriers changes by  $12\text{ J}$ .

9702/11/O/N/12/Q32

What is the current between  $X$  and  $Y$ ?

- A**  $0.040\text{ A}$
- B**  $0.11\text{ A}$
- C**  $9.0\text{ A}$
- D**  $25\text{ A}$

210 Four identical resistors are connected in the three networks below.

9702/12/M/J/12/Q38

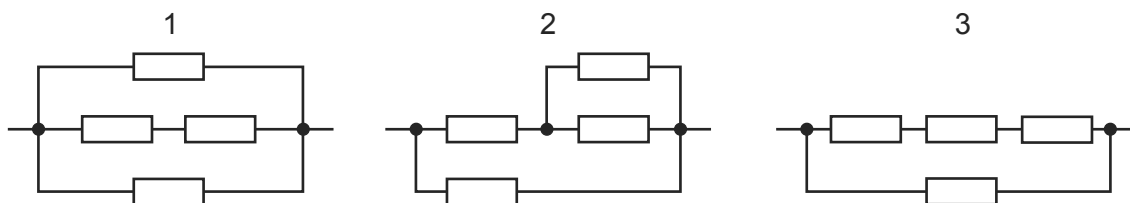

Which arrangement has the highest total resistance and which has the lowest?

	highest	lowest
<b>A</b>	1	2
<b>B</b>	1	3
<b>C</b>	3	1
<b>D</b>	3	2

211 The diagram shows a simple circuit.

9702/13/M/J/12/Q36

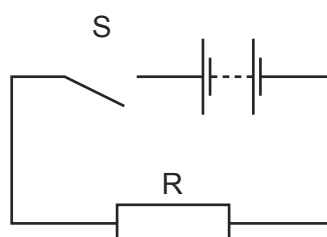

Which statement is correct?

- A** When switch S is closed, the electromotive force (e.m.f.) of the battery falls because work is done against the internal resistance of the battery.
- B** When switch S is closed, the e.m.f. of the battery falls because work is done against the resistance R.
- C** When switch S is closed, the potential difference across the battery falls because work is done against the internal resistance of the battery.
- D** When switch S is closed, the potential difference across the battery falls because work is done against the resistance R.

212 A cylindrical wire of length 10 m and diameter 2.0 mm has a resistance of  $0.050 \Omega$ . 9702/11/O/N/12/Q33

From which material is the wire made?

	material	resistivity/ $\Omega \text{ m}$
<b>A</b>	bronze	$1.6 \times 10^{-7}$
<b>B</b>	nichrome	$1.6 \times 10^{-6}$
<b>C</b>	silver	$1.6 \times 10^{-8}$
<b>D</b>	zinc	$6.3 \times 10^{-8}$

213 The circuit below has a current  $I$  in the resistor R.

9702/13/M/J/12/Q37

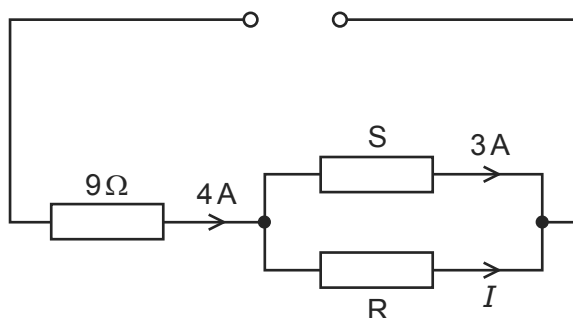

What must be known in order to determine the value of  $I$ ?

- A e.m.f. of the power supply
- B resistance of resistor S
- C Kirchhoff's first law
- D Kirchhoff's second law

214 The  $I$ - $V$  characteristics of two electrical components P and Q are shown below.

9702/11/O/N/12/Q34

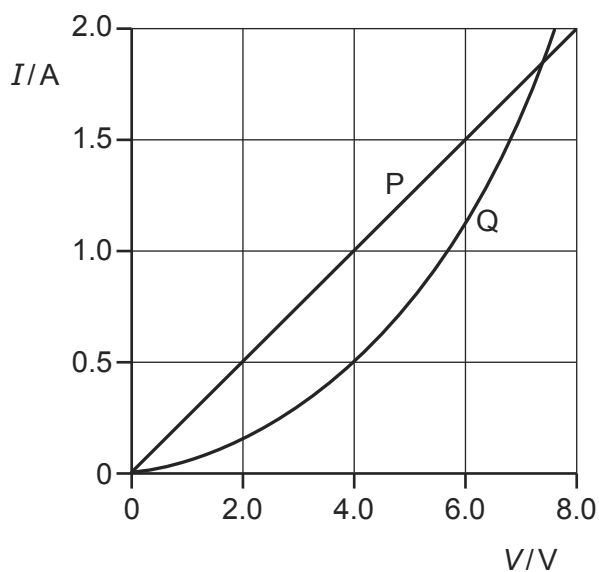

Which statement is correct?

- A P is a resistor and Q is a filament lamp.
- B The resistance of Q increases as the current in it increases.
- C For a current of  $1.9\text{ A}$ , the resistance of Q is approximately half that of P.
- D For a current of  $0.5\text{ A}$ , the power dissipated in Q is double that in P.

- 215 The graph shows the variation with length  $l$  of resistance  $R$  for two wires X and Y made from the same material. 9702/12/O/N/12/Q34

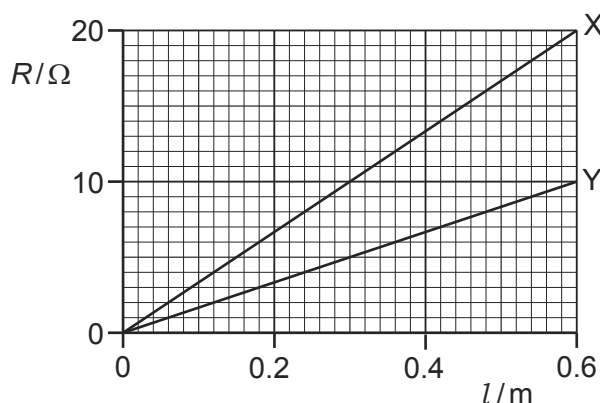

What does the graph show?

- A** cross-sectional area of X =  $2 \times$  cross-sectional area of Y
  - B** resistivity of X =  $2 \times$  resistivity of Y
  - C** when equal lengths of X and Y are connected in series to a battery, power in X =  $2 \times$  power in Y
  - D** when equal lengths of X and Y are connected in parallel to a battery, current in X =  $2 \times$  current in Y
- 216 A cell of internal resistance  $2.0\Omega$  and electromotive force (e.m.f.)  $1.5\text{V}$  is connected to a resistor of resistance  $3.0\Omega$ . 9702/12/O/N/12/Q35

What is the potential difference across the  $3.0\Omega$  resistor?

- A**  $1.5\text{V}$
  - B**  $1.2\text{V}$
  - C**  $0.9\text{V}$
  - D**  $0.6\text{V}$
- 217 A  $100\Omega$  resistor conducts a current with changing direction and magnitude, as shown. 9702/12/O/N/12/Q36

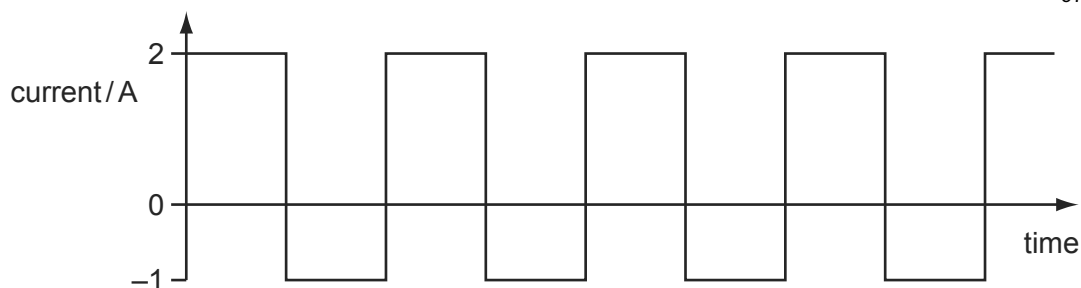

What is the mean power dissipated in the resistor?

- A**  $100\text{W}$
- B**  $150\text{W}$
- C**  $250\text{W}$
- D**  $400\text{W}$



- 218 A network of electrical components is connected across a battery of negligible internal resistance, as shown.

9702/11/O/N/12/Q36

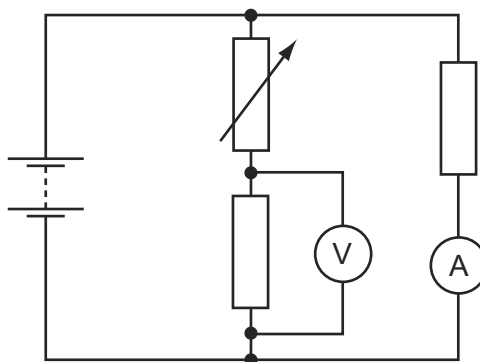

The resistance of the variable resistor is increased.

What is the effect on the readings of the ammeter and voltmeter?

	ammeter	voltmeter
<b>A</b>	decreases	increases
<b>B</b>	increases	decreases
<b>C</b>	unchanged	decreases
<b>D</b>	unchanged	increases

- 219 The diagram shows a potentiometer circuit.

9702/11/O/N/12/Q37

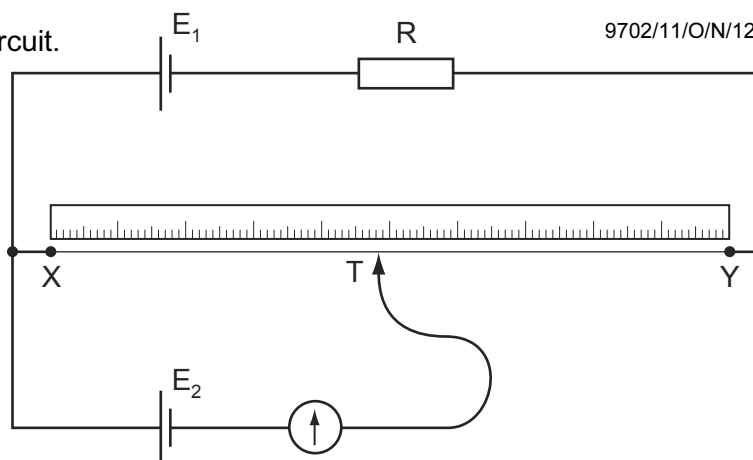

The contact T is placed on the wire and moved along the wire until the galvanometer reading is zero. The length XT is then noted.

In order to calculate the potential difference per unit length of the wire XY, which value must also be known?

- A** the e.m.f. of the cell  $E_1$
- B** the e.m.f. of the cell  $E_2$
- C** the resistance of resistor R
- D** the resistance of the wire XY

220 The ammeter reading in the circuit below is  $I$ .

9702/12/O/N/12/Q37

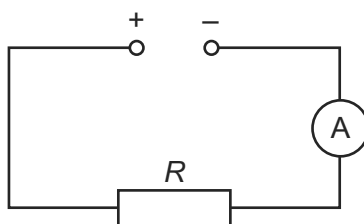

Another circuit containing the same voltage supply, two switches, an ammeter and two resistors each of resistance  $R$ , is shown.

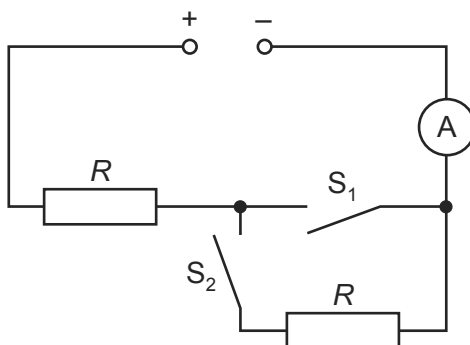

Which row is **not** correct?

	$S_1$	$S_2$	ammeter reading
<b>A</b>	closed	closed	$I$
<b>B</b>	closed	open	$I$
<b>C</b>	open	closed	$I$
<b>D</b>	open	open	0

221 A power supply of electromotive force (e.m.f.)  $12\text{ V}$  and internal resistance  $2.0\ \Omega$  is connected in series with a  $13\ \Omega$  resistor.

9702/11/M/J/13/Q32

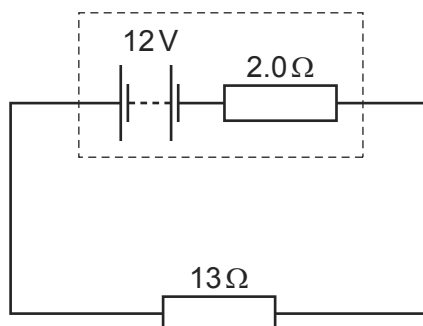

What is the power dissipated in the  $13\ \Omega$  resistor?

- A**  $8.3\text{ W}$       **B**  $9.6\text{ W}$       **C**  $10\text{ W}$       **D**  $11\text{ W}$

- 222 A light-dependent resistor  $R$  has resistance of about  $1\text{ M}\Omega$  in the dark and about  $1\text{ k}\Omega$  when illuminated. It is connected in series with a  $5\text{ k}\Omega$  resistor to a  $1.5\text{ V}$  cell of negligible internal resistance.

9702/12/O/N/12/Q38

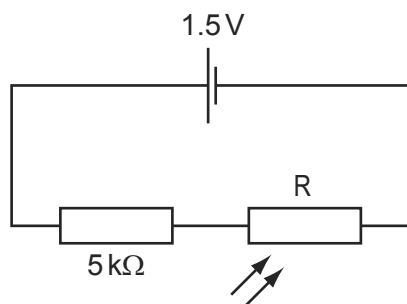

The light-dependent resistor is illuminated (in an otherwise dark room) by a flashing light.

Which graph best shows the variation with time  $t$  of potential difference  $V$  across  $R$ ?

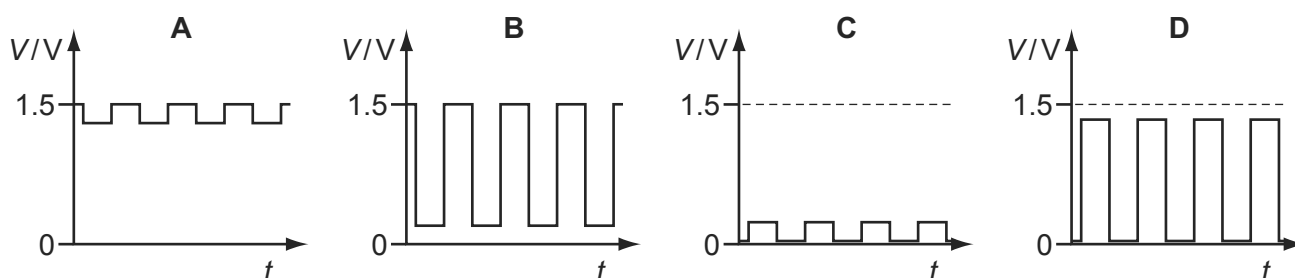

- 223 A copper wire is stretched so that its diameter is reduced from  $1.0\text{ mm}$  to a uniform  $0.5\text{ mm}$ .

9702/12/O/N/12/Q33

The resistance of the unstretched copper wire is  $0.2\ \Omega$ .

What will be the resistance of the stretched wire?

- A**  $0.4\ \Omega$       **B**  $0.8\ \Omega$       **C**  $1.6\ \Omega$       **D**  $3.2\ \Omega$

- 224 Four statements about potential difference or electromotive force are listed.

9702/12/O/N/12/Q34

- 1 It involves changing electrical energy into other forms.
- 2 It involves changing other energy forms into electrical energy.
- 3 It is the energy per unit charge to move charge right round a circuit.
- 4 It is the work done per unit charge by the charge moving from one point to another.

Which statements apply to potential difference and which apply to electromotive force?

	potential difference	electromotive force
<b>A</b>	1 and 3	2 and 4
<b>B</b>	1 and 4	2 and 3
<b>C</b>	2 and 3	1 and 4
<b>D</b>	2 and 4	1 and 3

- 225 The diagram shows a four-terminal box connected to a battery and two ammeters. 9702/12/O/N/12/Q35

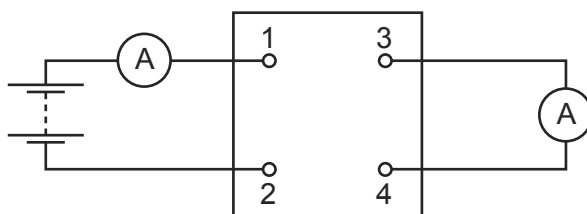

The currents in the two meters are identical.

Which circuit, within the box, will give this result?

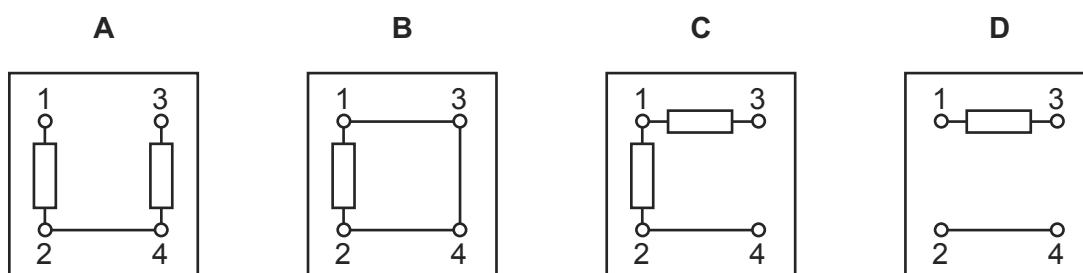

- 226 The diagram shows a resistor network. The potential difference across the network is  $V$ . 9702/12/O/N/12/Q37

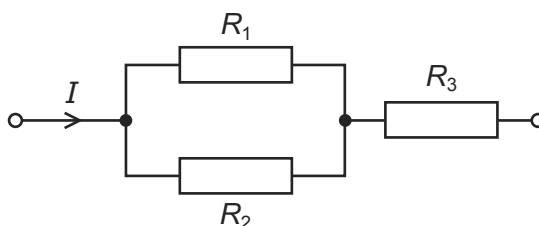

Is the equation shown below correct for the network?

$$V = I(1/R_1 + 1/R_2 + R_3)$$

- A** Yes, it correctly combines two series resistors with one parallel resistor, and correctly uses Ohm's Law.
- B** Yes, it correctly combines two parallel resistors with one series resistor, and correctly uses Ohm's Law.
- C** No, because it should read  $V = I \div (1/R_1 + 1/R_2 + R_3)$ .
- D** No, because the terms  $1/R_2$  and  $R_3$  have different units and cannot be added.
- 227 A low-voltage supply with an e.m.f. of 20 V and an internal resistance of  $1.5 \Omega$  is used to supply power to a heater of resistance  $6.5 \Omega$  in a fish tank. 9702/12/M/J/13/Q33

What is the power supplied to the water in the fish tank?

- A** 41 W      **B** 50 W      **C** 53 W      **D** 62 W

- 228 In the circuit below, P is a potentiometer of total resistance  $10\Omega$  and Q is a fixed resistor of resistance  $10\Omega$ . The battery has an e.m.f. of  $4.0\text{V}$  and negligible internal resistance. The voltmeter has a very high resistance.

9702/12/O/N/12/Q36

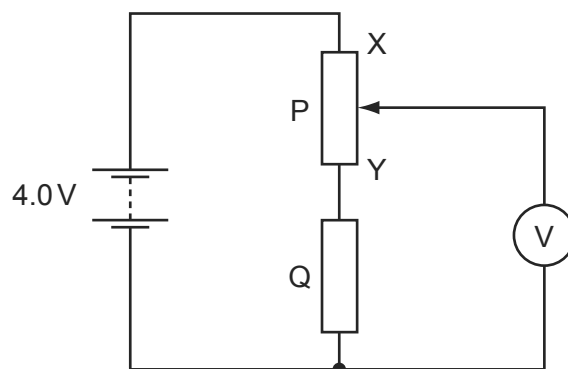

The slider on the potentiometer is moved from X to Y and a graph of voltmeter reading  $V$  is plotted against slider position.

Which graph is obtained?

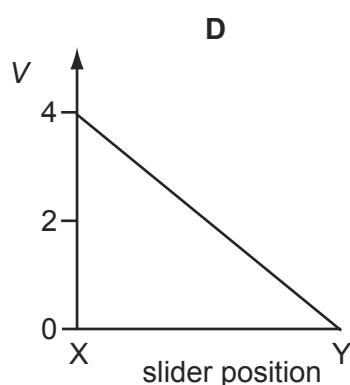
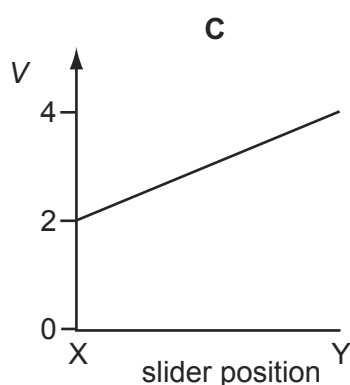
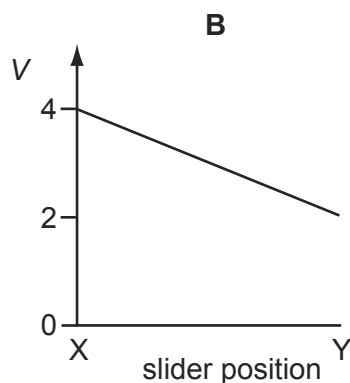
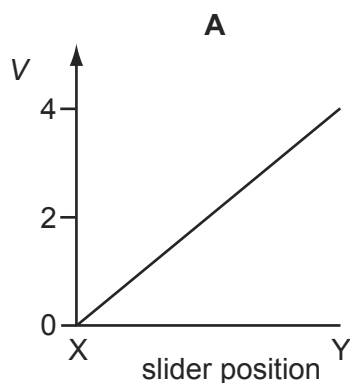

- 229 A power cable has length  $2000\text{m}$ . The cable is made of twelve parallel strands of copper wire, each with diameter  $0.51\text{mm}$ .

9702/12/M/J/13/Q32

What is the resistance of the cable? (resistivity of copper =  $1.7 \times 10^{-8}\Omega\text{m}$ )

- A**  $0.014\Omega$       **B**  $3.5\Omega$       **C**  $14\Omega$       **D**  $166\Omega$

230 Five resistors are connected as shown.

9702/12/M/J/13/Q37

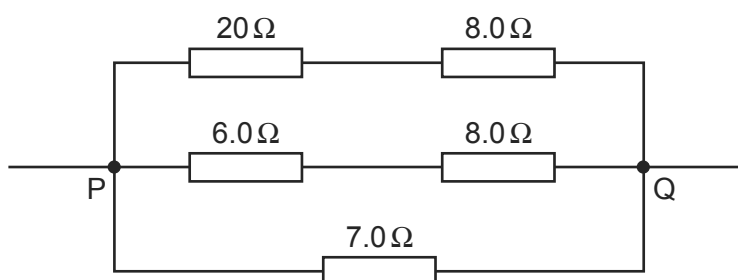

What is the total resistance between P and Q?

- A**  $0.25\ \Omega$       **B**  $0.61\ \Omega$       **C**  $4.0\ \Omega$       **D**  $16\ \Omega$

231 When a battery is connected to a resistor, the battery gradually becomes warm. This causes the internal resistance of the battery to increase whilst its e.m.f. stays unchanged.

As the internal resistance of the battery increases, how do the terminal potential difference and the output power change, if at all?

9702/11/M/J/13/Q33

	terminal potential difference	output power
<b>A</b>	decrease	decrease
<b>B</b>	decrease	unchanged
<b>C</b>	unchanged	decrease
<b>D</b>	unchanged	unchanged

232 The principles of conservation of which two quantities are associated with Kirchhoff's first and second laws?

9702/11/M/J/13/Q34

	first law	second law
<b>A</b>	charge	energy
<b>B</b>	charge	voltage
<b>C</b>	energy	charge
<b>D</b>	voltage	charge

233 A filament lamp has a resistance of  $180\ \Omega$  when the current in it is  $500\ \text{mA}$ .

9702/12/M/J/13/Q34

What is the power transformed in the lamp?

- A**  $45\ \text{W}$       **B**  $50\ \text{W}$       **C**  $90\ \text{W}$       **D**  $1400\ \text{W}$

234 A circuit is set up as shown, supplied by a 3V battery. All resistances are  $1\text{ k}\Omega$ .

9702/11/M/J/13/Q35

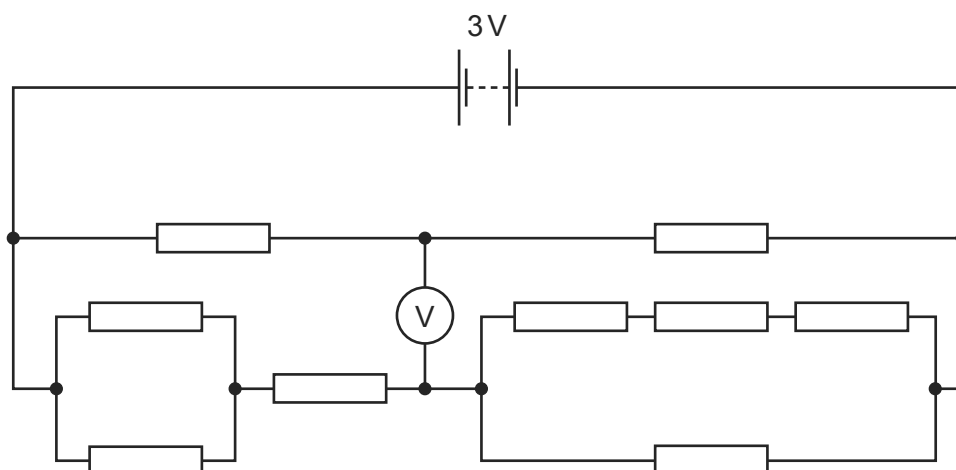

What will be the reading on the voltmeter?

- A** 0                      **B** 0.5V                      **C** 1.0V                      **D** 1.5V

235 A 12V battery is in series with an ammeter, a  $2\Omega$  fixed resistor and a  $0-10\Omega$  variable resistor. A high-resistance voltmeter is connected across the variable resistor.

9702/11/M/J/13/Q37

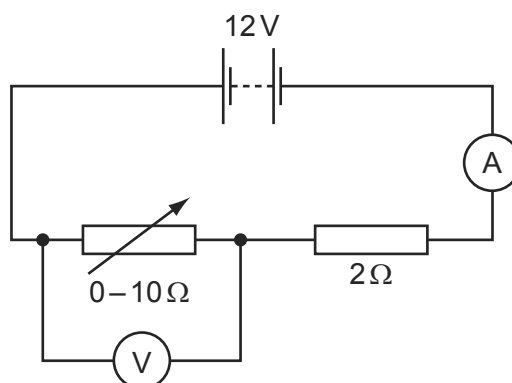

The resistance of the variable resistor is changed from zero to its maximum value.

Which graph shows how the potential difference (p.d.) measured by the voltmeter varies with the current measured by the ammeter?

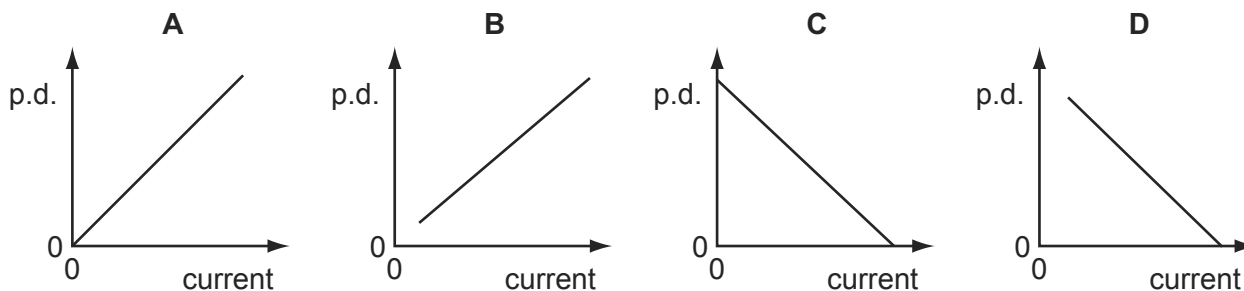

- 236 The diagram shows an incorrectly connected circuit. The ammeter has a resistance of  $0.1\ \Omega$  and the voltmeter has a resistance of  $1\ \text{M}\Omega$ .

9702/11/M/J/13/Q36

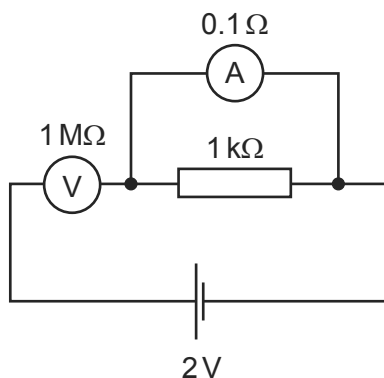

Which statement is correct?

- A** The ammeter reads 2 mA.  
**B** The ammeter reads 20 A.  
**C** The voltmeter reads zero.  
**D** The voltmeter reads 2 V.
- 237 In the circuit below, the reading  $V_T$  on the voltmeter changes from high to low as the temperature of the thermistor changes. The reading  $V_L$  on the voltmeter changes from high to low as the level of light on the light-dependent resistor (LDR) changes.

9702/12/M/J/13/Q38

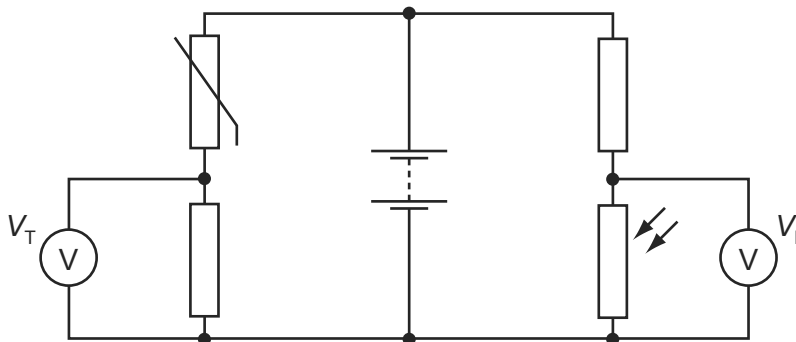

The readings  $V_T$  and  $V_L$  are both high.

What are the conditions of temperature and light level?

	temperature	light level
<b>A</b>	low	low
<b>B</b>	low	high
<b>C</b>	high	low
<b>D</b>	high	high



- 238 A 12V battery is in series with an ammeter, a  $2\Omega$  fixed resistor and a  $0-10\Omega$  variable resistor. High-resistance voltmeters P and Q are connected across the variable resistor and the fixed resistor respectively, as shown.

9702/12/M/J/13/Q36

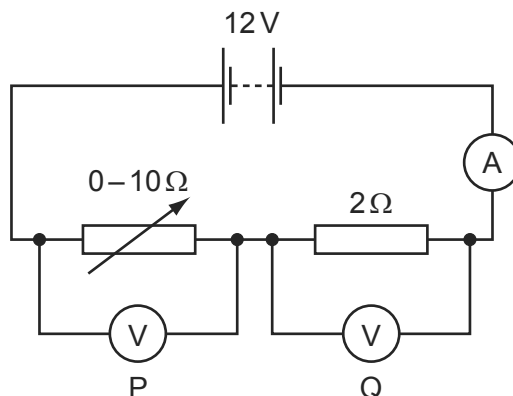

The resistance of the variable resistor is changed from its maximum value to zero.

Which graph shows the variation with current of the voltmeter readings?

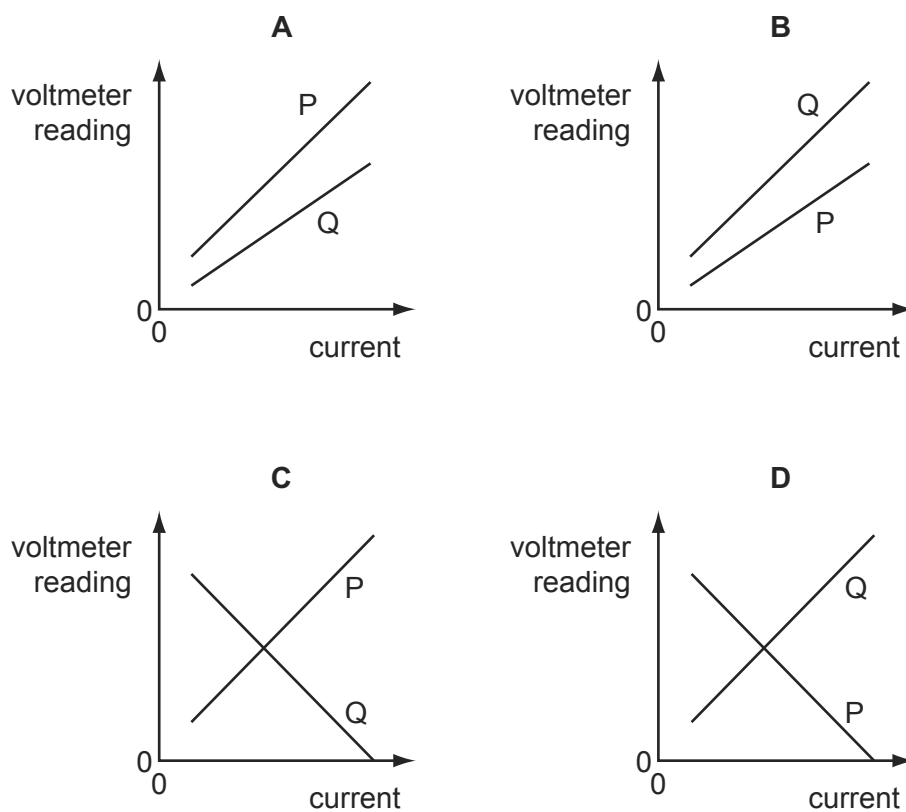

- 239 Two wires P and Q made of the same material are connected to the same electrical supply. P has twice the length of Q and one-third of the diameter of Q, as shown in the diagram.

9702/12/M/J/13/Q35

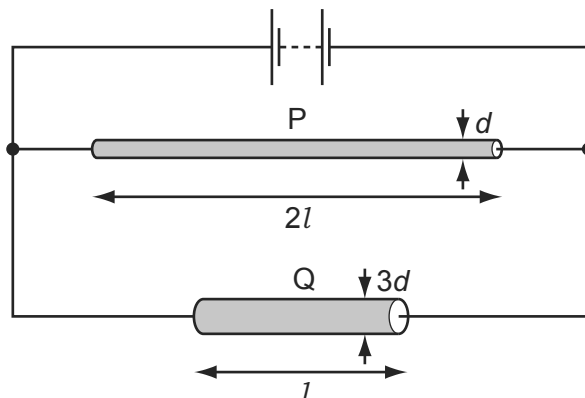

What is the ratio  $\frac{\text{current in P}}{\text{current in Q}}$ ?

- A**  $\frac{2}{3}$       **B**  $\frac{2}{9}$       **C**  $\frac{1}{6}$       **D**  $\frac{1}{18}$

- 240 Two cells X and Y are connected in series with a resistor of resistance  $9.0\Omega$ , as shown.

9702/13/M/J/13/Q31

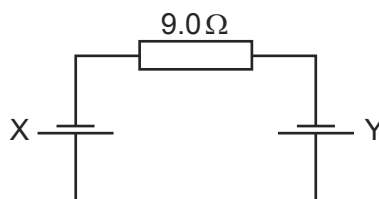

Cell X has an electromotive force (e.m.f.) of  $1.0\text{V}$  and an internal resistance of  $1.0\Omega$ . Cell Y has an e.m.f. of  $2.0\text{V}$  and an internal resistance of  $2.0\Omega$ .

What is the current in the circuit?

- A**  $0.25\text{A}$       **B**  $0.17\text{A}$       **C**  $0.10\text{A}$       **D**  $0.083\text{A}$

- 241 An electric power cable consists of six copper wires c surrounding a steel core s.

9702/13/M/J/13/Q34

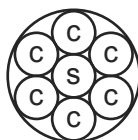

A length of  $1.0\text{km}$  of one of the copper wires has a resistance of  $10\Omega$  and  $1.0\text{km}$  of the steel core has a resistance of  $100\Omega$ .

What is the approximate resistance of a  $1.0\text{km}$  length of the power cable?

- A**  $0.61\Omega$       **B**  $1.6\Omega$       **C**  $160\Omega$       **D**  $610\Omega$

242 The graph shows how current  $I$  varies with voltage  $V$  for a filament lamp.

9702/13/M/J/13/Q33

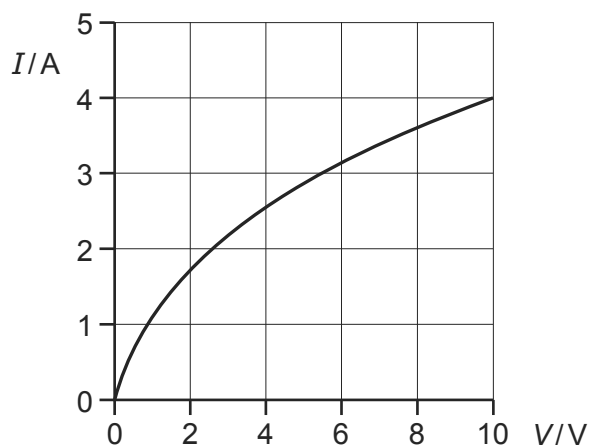

Since the graph is not a straight line, the resistance of the lamp varies with  $V$

Which row gives the correct resistance at the stated value of  $V$ ?

	$V/V$	$R/\Omega$
<b>A</b>	2.0	1.5
<b>B</b>	4.0	3.2
<b>C</b>	6.0	1.9
<b>D</b>	8.0	0.9

243 The circular cross-sectional area of a metal wire varies along its length. There is a current in the wire. The narrow end of the wire is at a reference potential of zero.

9702/13/M/J/13/Q32

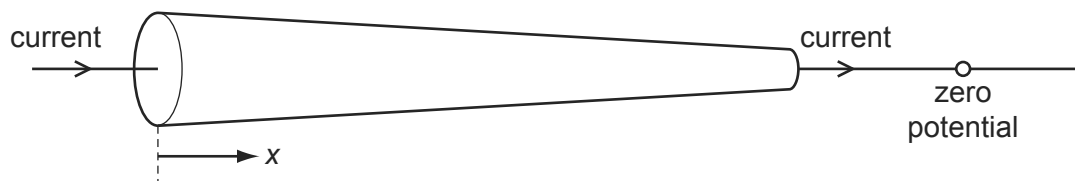

Which graph best represents the variation with distance  $x$  along the wire of the potential difference  $V$  relative to the reference zero?

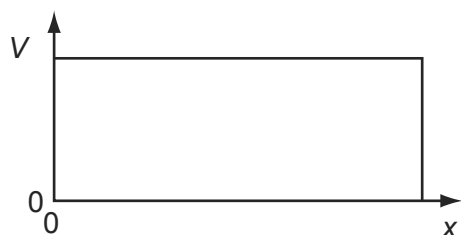
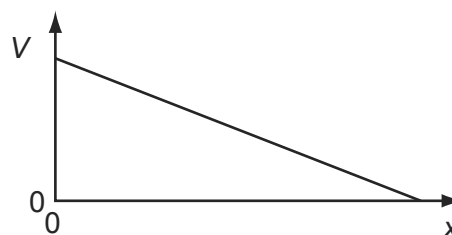
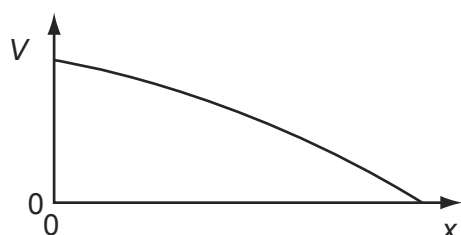
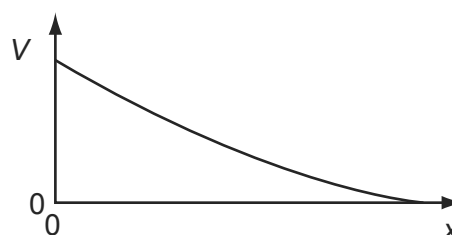
**A****B****C****D**

- 244 The diagram shows a length of track from a model railway connected to a battery, a resistor and a relay coil. 9702/13/M/J/13/Q35

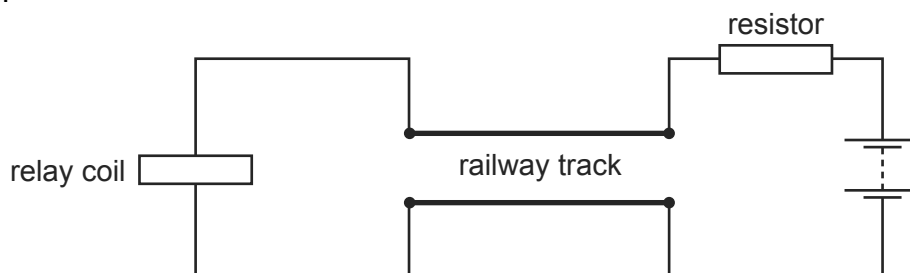

With no train present, there is a current in the relay coil which operates a switch to turn on a light.

When a train occupies the section of track, most of the current flows through the wheels and axles of the train in preference to the relay coil. The switch in the relay turns off the light.

Why is a resistor placed between the battery and the track?

- A** to limit the heating of the wheels of the train
  - B** to limit the energy lost in the relay coil when a train is present
  - C** to prevent a short circuit of the battery when a train is present
  - D** to protect the relay when a train is present
- 245 A 12V battery is in series with an ammeter, a  $2\Omega$  fixed resistor and a  $0-10\Omega$  variable resistor. A high-resistance voltmeter is connected across the fixed resistor. 9702/13/M/J/13/Q36

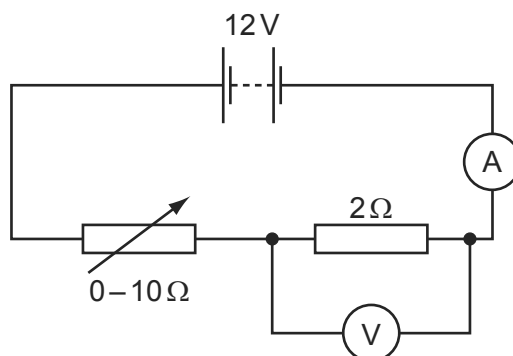

The resistance of the variable resistor is changed from zero to its maximum value.

Which graph shows how the potential difference (p.d.) measured by the voltmeter varies with the current measured by the ammeter?

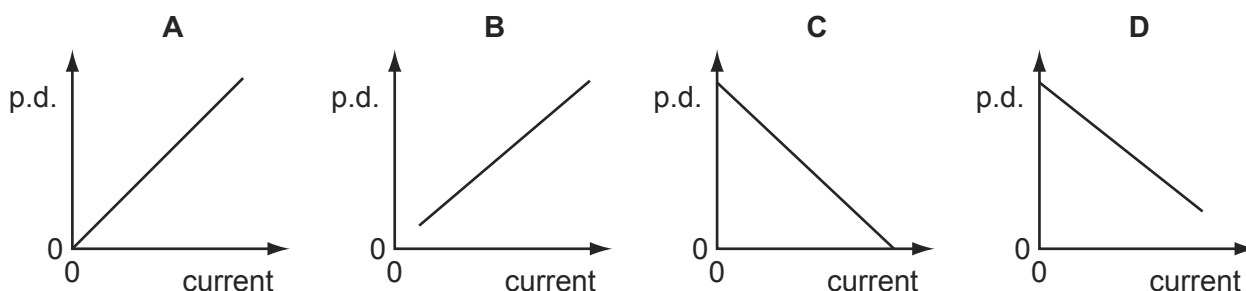

246 In the circuit shown, the battery and ammeter each have negligible resistance.

9702/13/M/J/13/Q37

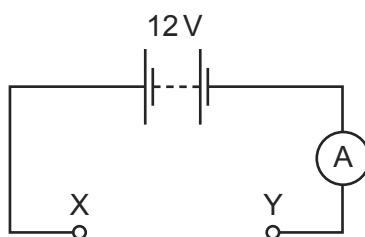

The following combinations of resistors are placed in turn between the terminals X and Y of the circuit.

Which combination would give an ammeter reading of 8 A?

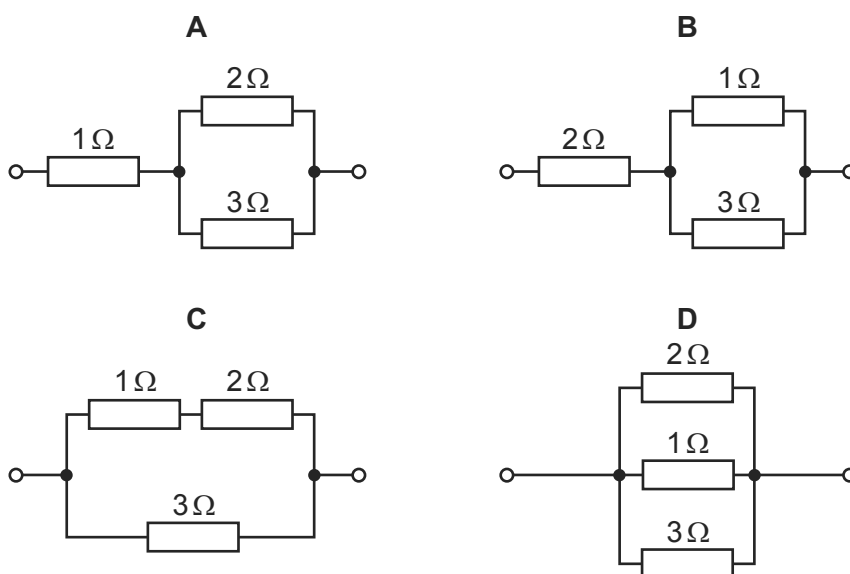

247 Four resistors of resistance  $R$ ,  $2R$ ,  $3R$  and  $4R$  are connected to form a network.

9702/11/O/N/13/Q38

A battery of negligible internal resistance and a voltmeter are connected to the resistor network as shown.

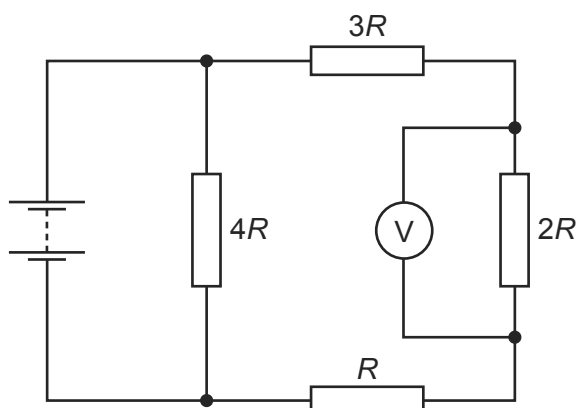

The voltmeter reading is 2 V.

What is the electromotive force (e.m.f.) of the battery?

- A** 2 V      **B** 4 V      **C** 6 V      **D** 10 V

- 248 In the circuit below, P is a potentiometer of total resistance  $10\Omega$  and Q is a fixed resistor of resistance  $10\Omega$ . The battery has an electromotive force (e.m.f.) of  $4.0\text{V}$  and negligible internal resistance. The voltmeter has a very high resistance.

9702/11/O/N/13/Q36

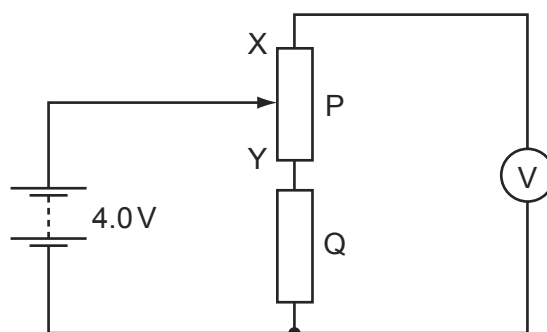

The slider on the potentiometer is moved from X to Y and a graph of voltmeter reading  $V$  is plotted against slider position.

Which graph would be obtained?

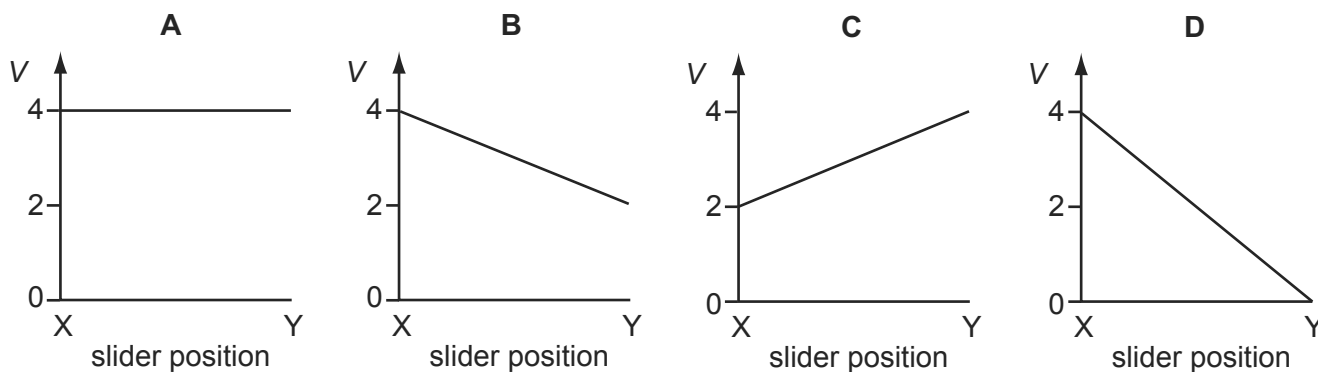

- 249 The diagram shows an electric circuit in which the resistance of the external resistor is  $2R$  and the internal resistance of the source is  $R$ .

9702/11/O/N/13/Q33

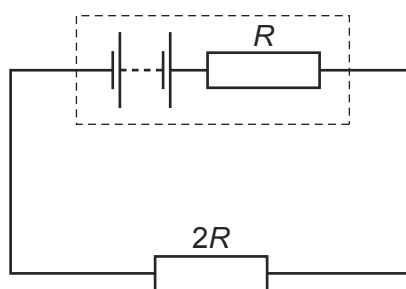

What is the ratio  $\frac{\text{power in external resistor}}{\text{power in internal resistance}}$  ?

- A  $\frac{1}{4}$       B  $\frac{1}{2}$       C 2      D 4

250 A  $2\ \Omega$  resistor and a  $4\ \Omega$  resistor are connected to a cell.

9702/11/O/N/13/Q37

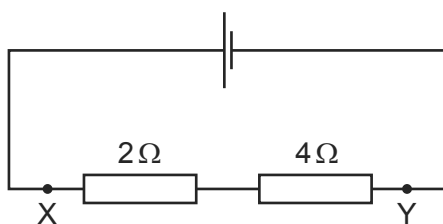

Which graph shows how the potential  $V$  varies with distance between X and Y?

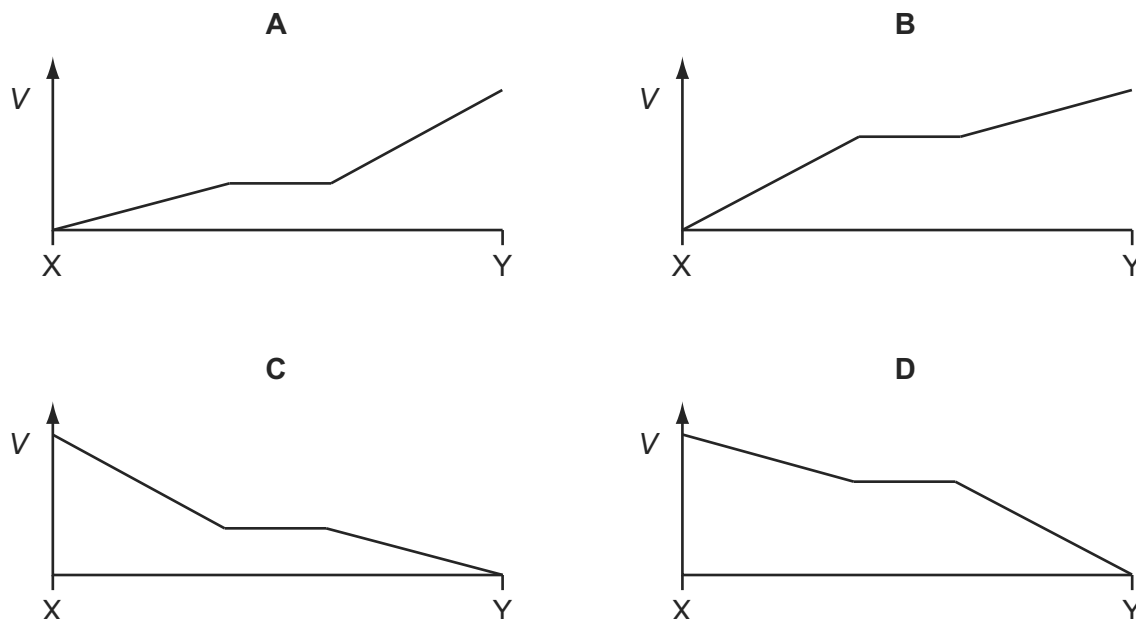

251 The wire of a heating element has resistance  $R$ . The wire breaks and is replaced by a different wire.

9702/11/O/N/13/Q35

Data for the original wire and the replacement wire are shown in the table.

	length	diameter	resistivity of metal
original wire	$l$	$d$	$\rho$
replacement wire	$l$	$2d$	$2\rho$

What is the resistance of the replacement wire?

- A**  $\frac{R}{4}$       **B**  $\frac{R}{2}$       **C**  $R$       **D**  $2R$

252 The current in a component is reduced uniformly from  $100\ \text{mA}$  to  $20\ \text{mA}$  over a period of  $8.0\ \text{s}$ .

9702/13/O/N/13/Q32

What is the charge that flows during this time?

- A**  $160\ \text{mC}$       **B**  $320\ \text{mC}$       **C**  $480\ \text{mC}$       **D**  $640\ \text{mC}$

- 253 Two lamps are connected in series to a 250V power supply. One lamp is rated 240V, 60W and the other is rated 10V, 2.5W. 9702/11/O/N/13/Q34

Which statement most accurately describes what happens?

- A** Both lamps light at less than their normal brightness.  
**B** Both lamps light normally.  
**C** Only the 60W lamp lights.  
**D** The 10V lamp blows.
- 254 An electric current is passed from a thick copper wire through a section of thinner copper wire before entering a second thick copper wire as shown. 9702/13/O/N/13/Q33

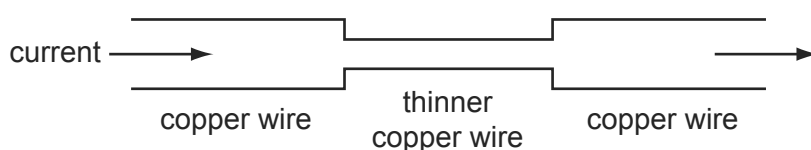

Which statement about the current and the speed of electrons in the wires is correct?

- A** The current and the speed of the electrons in the thinner wire are both less than in the thicker copper wires.  
**B** The current and the speed of the electrons is the same in all the wires.  
**C** The current is the same in all the wires but the speed of the electrons in the thinner wire is greater than in the thicker wires.  
**D** The current is the same in all the wires but the speed of the electrons in the thinner wire is less than in the thicker wire.
- 255 An electrical device of fixed resistance  $20\Omega$  is connected in series with a variable resistor and a battery of electromotive force (e.m.f.) 16V and negligible internal resistance. 9702/13/O/N/13/Q34

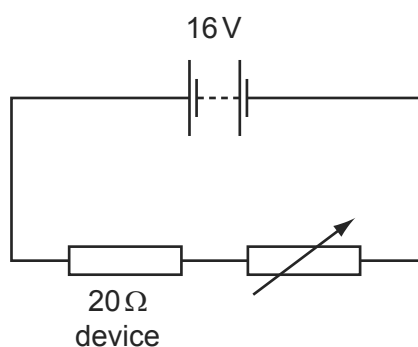

What is the resistance of the variable resistor when the power dissipated in the electrical device is 4.0W?

- A**  $16\Omega$       **B**  $36\Omega$       **C**  $44\Omega$       **D**  $60\Omega$



256 A copper wire is cylindrical and has resistance  $R$ .

9702/13/O/N/13/Q35

What will be the resistance of a copper wire of twice the length and twice the radius?

- A**  $\frac{R}{4}$       **B**  $\frac{R}{2}$       **C**  $R$       **D**  $2R$

257 The diagram shows the electric motor for a garden pump connected to a 24 V power supply by an insulated two-core cable.

9702/13/O/N/13/Q36

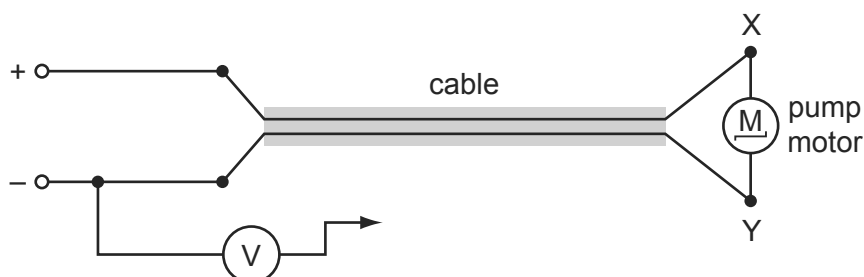

The motor does not work so, to find the fault, the negative terminal of a voltmeter is connected to the negative terminal of the power supply and its other end is connected in turn to terminals X and Y at the motor.

Which row represents two readings and a correct conclusion?

	voltmeter reading when connected to X/V	voltmeter reading when connected to Y/V	conclusion
<b>A</b>	24	0	break in positive wire of cable
<b>B</b>	24	12	break in negative wire of cable
<b>C</b>	24	24	break in connection within the motor
<b>D</b>	24	24	break in negative wire of cable

258 Two wires P and Q made of the same material and of the same length are connected in parallel to the same voltage supply. Wire P has diameter 2 mm and wire Q has diameter 1 mm.

9702/13/M/J/14/Q33

What is the ratio  $\frac{\text{current in P}}{\text{current in Q}}$  ?

- A**  $\frac{1}{4}$       **B**  $\frac{1}{2}$       **C**  $\frac{2}{1}$       **D**  $\frac{4}{1}$

259 In the circuit shown, the resistance of the thermistor decreases as temperature increases.

9702/13/O/N/13/Q37

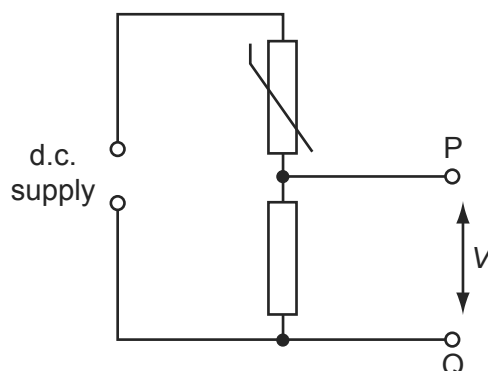

Which graph shows the variation with Celsius temperature  $\theta$  of potential difference  $V$  between points P and Q?

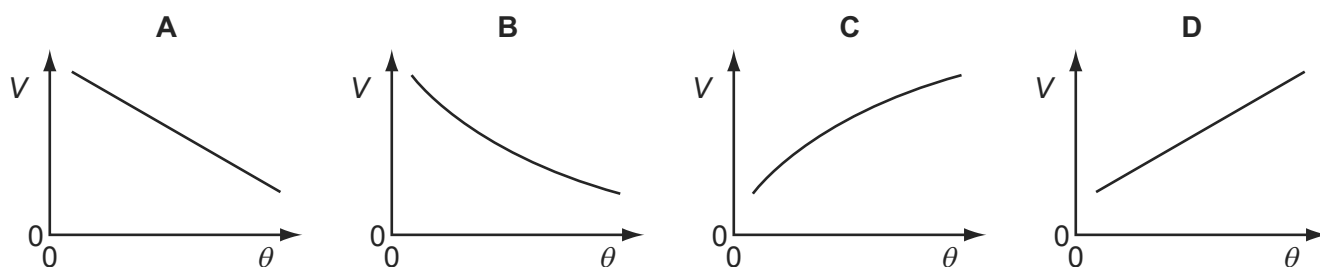

260 A 20V d.c. supply is connected to a circuit consisting of five resistors L, M, N, P and Q.

9702/13/O/N/13/Q38

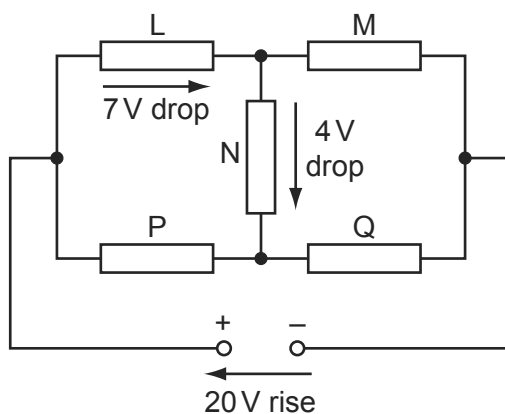

There is a potential drop of 7 V across L and a further 4 V potential drop across N.

What are the potential drops across M, P and Q?

	potential drop across M/V	potential drop across P/V	potential drop across Q/V
<b>A</b>	9	7	13
<b>B</b>	13	7	13
<b>C</b>	13	11	9
<b>D</b>	17	3	17

- 261 A battery of electromotive force (e.m.f.)  $V$  and negligible internal resistance is connected to a  $1\text{ k}\Omega$  resistor, as shown.

9702/12/M/J/14/Q30

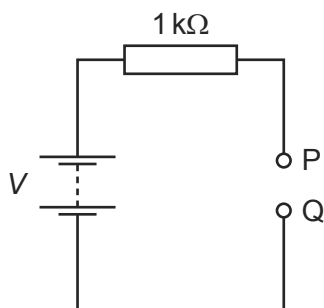

A student attempts to measure the potential difference (p.d.) between points P and Q using two voltmeters, one at a time. The first voltmeter has a resistance of  $1\text{ k}\Omega$  and the second voltmeter has a resistance of  $1\text{ M}\Omega$ .

What are the readings of the voltmeters?

	reading on voltmeter with $1\text{ k}\Omega$ resistance	reading on voltmeter with $1\text{ M}\Omega$ resistance
<b>A</b>	$\frac{V}{2}$	$\frac{V}{2}$
<b>B</b>	$\frac{V}{2}$	$V$
<b>C</b>	$V$	$\frac{V}{2}$
<b>D</b>	$V$	$V$

- 262 The diagram shows an electric pump for a garden fountain connected by an  $18\text{ m}$  cable to a  $230\text{ V}$  mains electrical supply.

9702/12/M/J/14/Q32

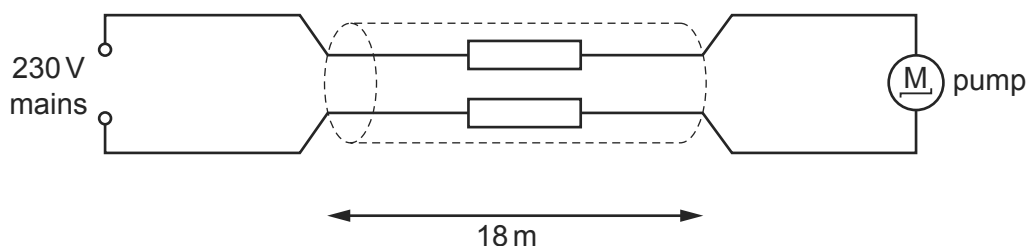

The performance of the pump is acceptable if the potential difference (p.d.) across it is at least  $218\text{ V}$ . The current through it is then  $0.83\text{ A}$ .

What is the maximum resistance per metre of each of the two wires in the cable if the pump is to perform acceptably?

- A**  $0.40\text{ }\Omega\text{ m}^{-1}$     **B**  $0.80\text{ }\Omega\text{ m}^{-1}$     **C**  $1.3\text{ }\Omega\text{ m}^{-1}$     **D**  $1.4\text{ }\Omega\text{ m}^{-1}$

- 263 Cell X has an e.m.f. of  $2.0\text{V}$  and an internal resistance of  $2.0\Omega$ . Cell Y has an e.m.f. of  $1.6\text{V}$  and an internal resistance of  $1.2\Omega$ . These two cells are connected to a resistor of resistance  $0.8\Omega$ , as shown.

9702/12/M/J/14/Q33

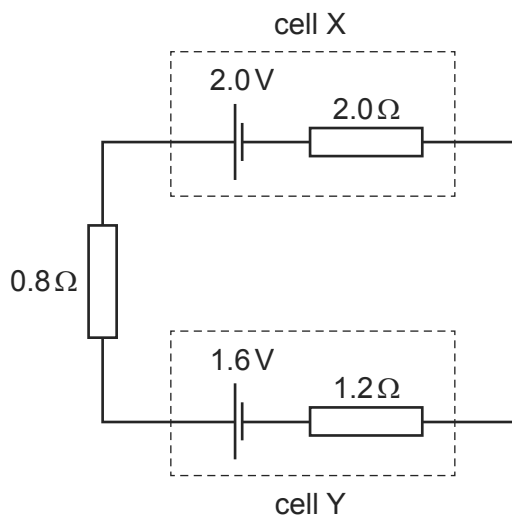

What is the current in cell X?

- A**  $0.10\text{A}$       **B**  $0.50\text{A}$       **C**  $0.90\text{A}$       **D**  $1.0\text{A}$
- 264 In the circuit shown, all the resistors are identical.

9702/12/M/J/14/Q36

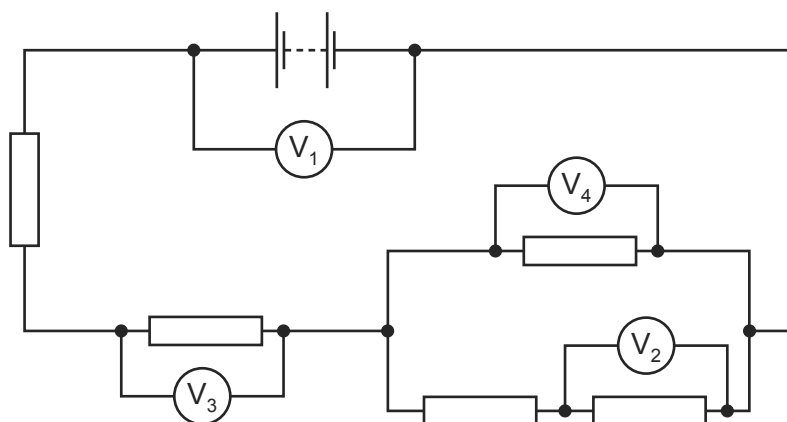

The reading on voltmeter  $V_1$  is  $8.0\text{V}$  and the reading on voltmeter  $V_2$  is  $1.0\text{V}$ .

What are the readings on the other voltmeters?

	reading on voltmeter $V_3/\text{V}$	reading on voltmeter $V_4/\text{V}$
<b>A</b>	1.5	1.0
<b>B</b>	3.0	2.0
<b>C</b>	4.5	3.0
<b>D</b>	6.0	4.0

- 265 In the circuit shown, a light-dependent resistor (LDR) is connected to two resistors  $R_1$  and  $R_2$ . The potential difference (p.d.) across  $R_1$  is  $V_1$  and the p.d. across  $R_2$  is  $V_2$ . The current in the circuit is  $I$ .

9702/12/M/J/14/Q34

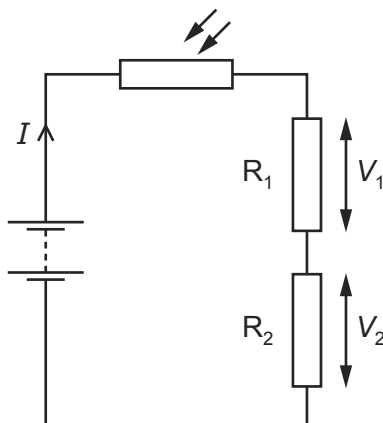

Which statement about this circuit is correct?

- A** The current  $I$  increases when the light intensity decreases.  
**B** The LDR is an ohmic conductor.  
**C** The p.d.  $V_2$  increases when the light intensity decreases.  
**D** The ratio  $\frac{V_1}{V_2}$  is independent of light intensity.
- 266 A power supply and a solar cell are compared using the potentiometer circuit shown. 9702/12/M/J/14/Q35

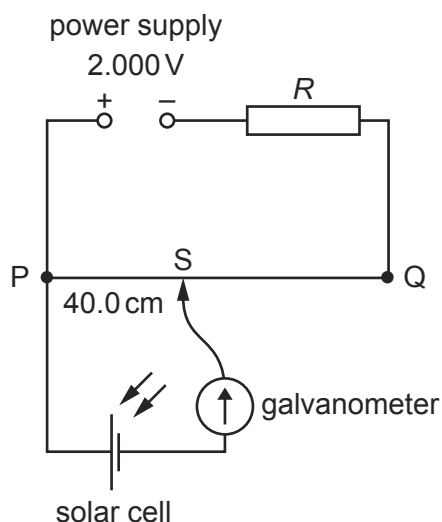

The e.m.f. produced by the solar cell is measured on the potentiometer.

The potentiometer wire PQ is 100.0 cm long and has a resistance of  $5.00 \Omega$ . The power supply has an e.m.f. of 2.000 V and the solar cell has an e.m.f. of 5.00 mV.

Which resistance  $R$  must be used so that the galvanometer reads zero when  $PS = 40.0$  cm?

- A**  $395 \Omega$       **B**  $795 \Omega$       **C**  $995 \Omega$       **D**  $1055 \Omega$

- 267 A cell has an electromotive force (e.m.f.) of  $6\text{V}$  and internal resistance  $R$ . An external resistor, also of resistance  $R$ , is connected across this cell, as shown.

9702/13/M/J/14/Q34

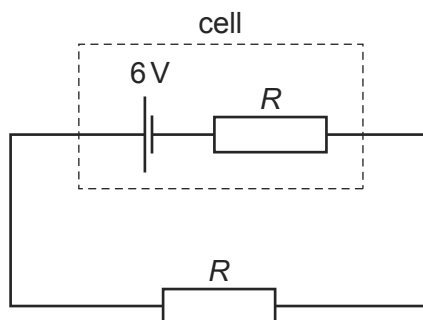

Power  $P$  is dissipated by the external resistor.

The cell is replaced by a different cell that has an e.m.f. of  $6\text{V}$  and negligible internal resistance.

What is the new power that is dissipated in the external resistor?

- A**  $0.5P$       **B**  $P$       **C**  $2P$       **D**  $4P$
- 268 What is the current in the  $40\Omega$  resistor of the circuit shown?

9702/13/M/J/14/Q37

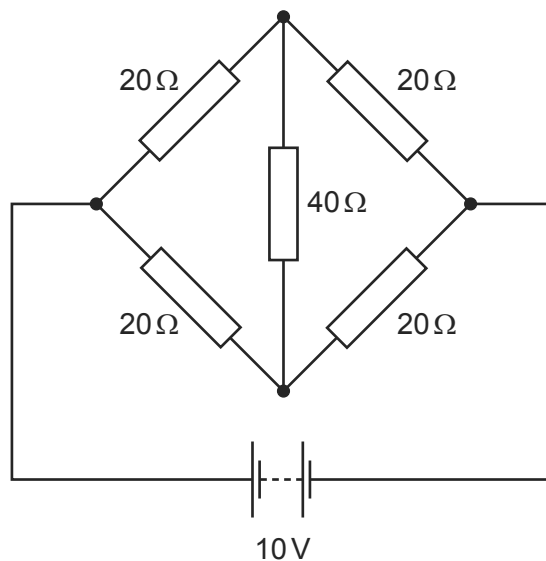

- A** zero      **B**  $0.13\text{A}$       **C**  $0.25\text{A}$       **D**  $0.50\text{A}$

- 269 The diagram shows a light-dependent resistor (LDR) and a thermistor forming a potential divider.

9702/13/M/J/14/Q37

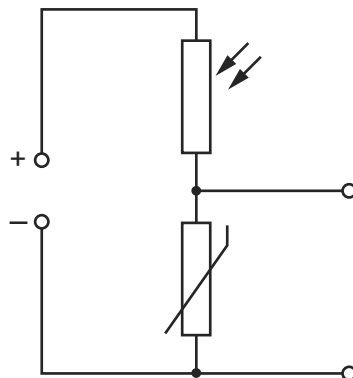

Under which set of conditions will the potential difference across the thermistor have the greatest value?

	illumination	temperature
<b>A</b>	low	low
<b>B</b>	high	low
<b>C</b>	low	high
<b>D</b>	high	high

- 270 The diagram shows a low-voltage circuit for heating the water in a fish tank.

9702/13/M/J/14/Q35

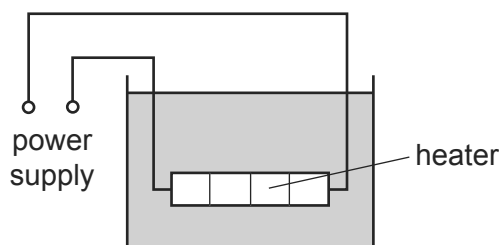

The heater has a resistance of  $3.0\Omega$ . The power supply has an e.m.f. of  $12\text{V}$  and an internal resistance of  $1.0\Omega$ .

At which rate is energy supplied to the heater?

- A** 27 W      **B** 36 W      **C** 48 W      **D** 64 W
- 271 A copper wire is to be replaced by an aluminium alloy wire of the same length and resistance. Copper has half the resistivity of the alloy.

9702/12/M/J/14/Q31

What is the ratio  $\frac{\text{diameter of alloy wire}}{\text{diameter of copper wire}}$ ?

- A**  $\sqrt{2}$       **B** 2      **C**  $2\sqrt{2}$       **D** 4

- 272 The diagrams show the same cell, ammeter, potentiometer and fixed resistor connected in different ways.

9702/13/M/J/14/Q36

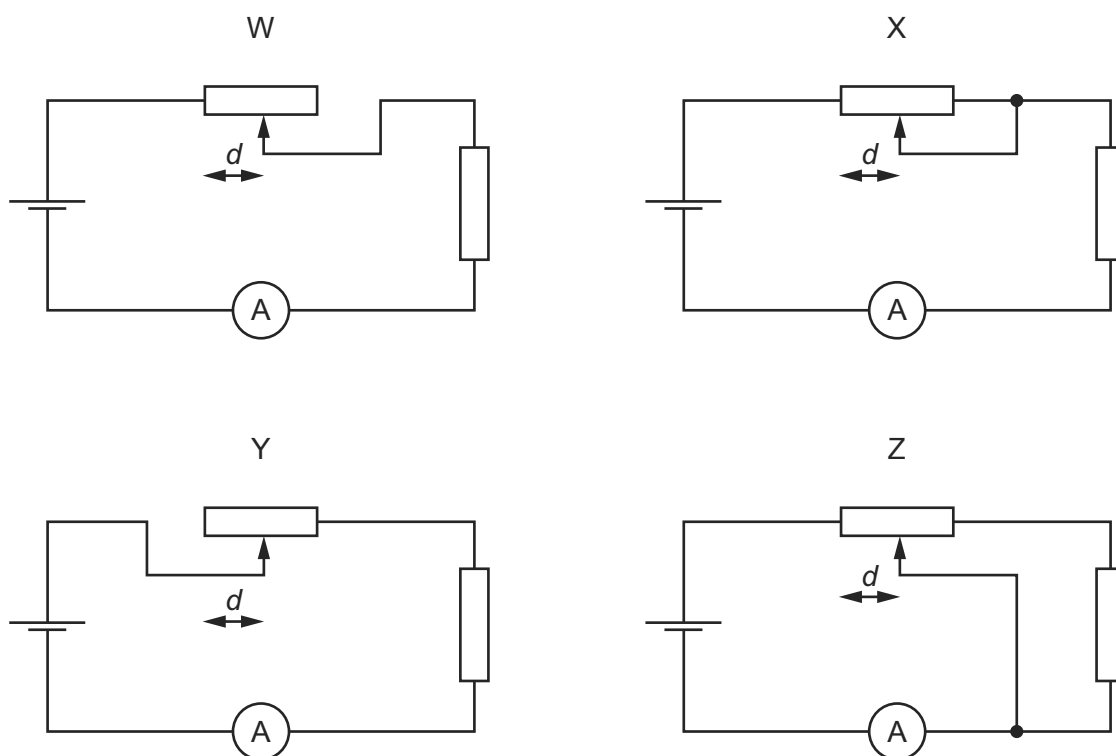

The distance  $d$  between the sliding contact and a particular end of the potentiometer is varied. The current measured is then plotted against the distance  $d$ .

For which two circuits will the graphs be identical?

- A** W and X      **B** W and Y      **C** X and Y      **D** Y and Z
- 273 A battery of negligible internal resistance is connected to a resistor network, an ammeter and a switch S, as shown.

9702/13/M/J/14/Q38

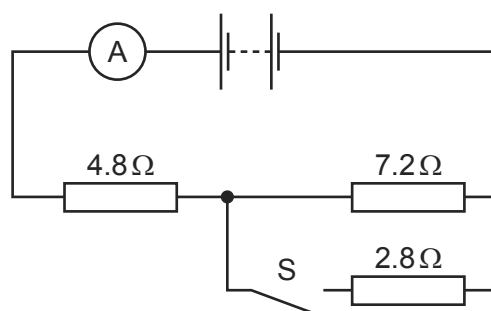

When S is open, the reading on the ammeter is 250 mA.

When S is closed, what is the **change** in the reading on the ammeter?

- A** 1.07 A      **B** 1.32 A      **C** 190 mA      **D** 440 mA



274 Two electrically-conducting cylinders X and Y are made from the same material.

9702/11/M/J/14/Q30

Their dimensions are as shown.

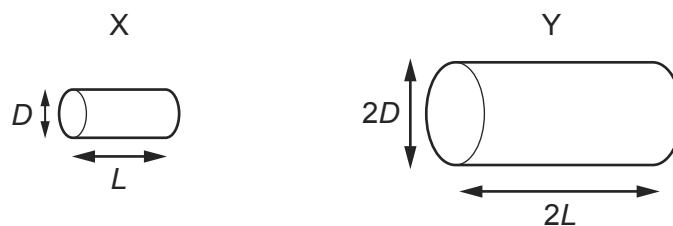

The resistance between the ends of each cylinder is measured.

What is the ratio  $\frac{\text{resistance of X}}{\text{resistance of Y}}$ ?

**A**  $\frac{2}{1}$

**B**  $\frac{1}{1}$

**C**  $\frac{1}{2}$

**D**  $\frac{1}{4}$

275 A battery, with a constant internal resistance, is connected to a resistor of resistance  $250\ \Omega$ , as shown.

9702/11/M/J/14/Q31

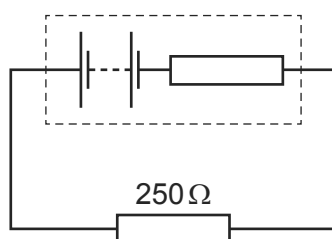

The current in the resistor is  $40\ \text{mA}$  for a time of  $60\ \text{s}$ . During this time  $6.0\ \text{J}$  of energy is lost in the internal resistance.

What are the energy supplied to the external resistor during the  $60\ \text{s}$  and the e.m.f. of the battery?

	energy / J	e.m.f. / V
<b>A</b>	2.4	2.4
<b>B</b>	2.4	7.5
<b>C</b>	24	10.0
<b>D</b>	24	12.5

276 Which symbol represents a component whose resistance is designed to change with temperature?

9702/11/M/J/14/Q32

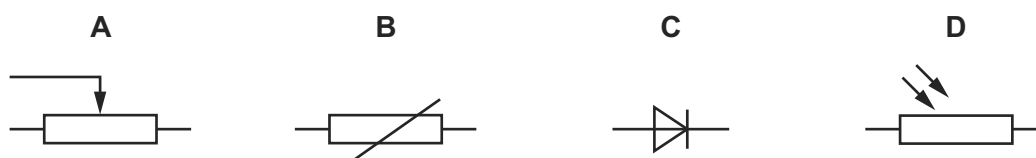

- 277 In the circuit below, a voltmeter of resistance  $R_V$  and an ammeter of resistance  $R_A$  are used to measure the resistance  $R$  of the fixed resistor.

9702/11/M/J/14/Q33

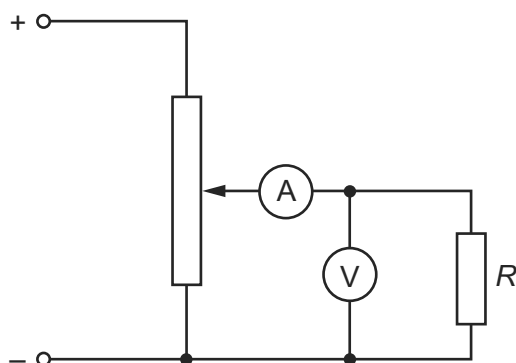

Which condition is necessary for an accurate value to be obtained for  $R$ ?

- A**  $R$  is much smaller than  $R_V$ .  
**B**  $R$  is much smaller than  $R_A$ .  
**C**  $R$  is much greater than  $R_V$ .  
**D**  $R$  is much greater than  $R_A$ .
- 278 In the circuit shown, all the resistors are identical and all the ammeters have negligible resistance.

9702/11/M/J/14/Q34

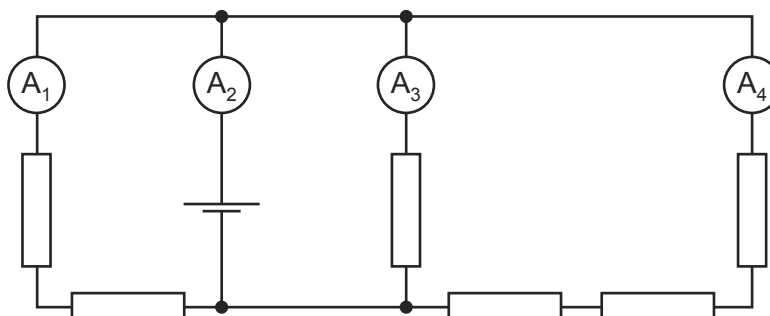

The reading on ammeter  $A_1$  is 0.6 A.

What are the readings on the other ammeters?

	reading on ammeter $A_2$ / A	reading on ammeter $A_3$ / A	reading on ammeter $A_4$ / A
<b>A</b>	1.0	0.3	0.1
<b>B</b>	1.4	0.6	0.2
<b>C</b>	1.8	0.9	0.3
<b>D</b>	2.2	1.2	0.4

279 The potential difference across a component in a circuit is 2.0 V.

9702/11/M/J/14/Q35

How many electrons must flow through this component in order for it to be supplied with 4.8 J of energy?

- A**  $2.6 \times 10^{18}$     **B**  $1.5 \times 10^{19}$     **C**  $3.0 \times 10^{19}$     **D**  $6.0 \times 10^{19}$

280 What is the total resistance between points P and Q in this network of resistors?

9702/11/M/J/14/Q36

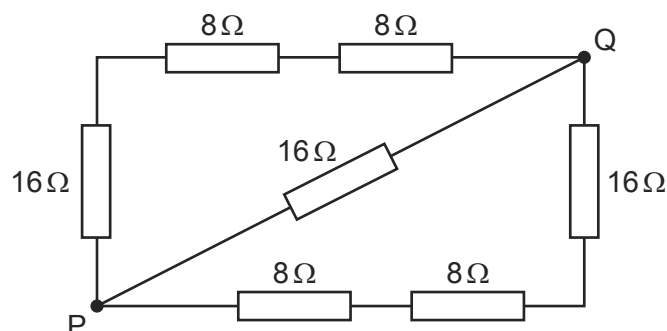

- A**  $8 \Omega$     **B**  $16 \Omega$     **C**  $24 \Omega$     **D**  $32 \Omega$

281 The combined resistance  $R_T$  of two resistors of resistances  $R_1$  and  $R_2$  connected in parallel is given by the formula shown.

9702/11/O/N/14/Q35

$$\frac{1}{R_T} = \frac{1}{R_1} + \frac{1}{R_2}$$

Which statement is used in the derivation of this formula?

- A** The currents through the two resistors are equal.  
**B** The potential difference across each resistor is the same.  
**C** The supply current is split between the two resistors in the same ratio as the ratio of their resistances.  
**D** The total power dissipated is the sum of the powers dissipated in the two resistors separately.

- 282 A pencil is used to draw a line of length 30 cm and width 1.2 mm. The resistivity of the material in the pencil is  $2.0 \times 10^{-5} \Omega\text{m}$  and the resistance of the line is 40 k $\Omega$ . 9702/11/O/N/14/Q32

What is the thickness of the line?

- A**  $1.25 \times 10^{-10} \text{ m}$   
**B**  $1.25 \times 10^{-8} \text{ m}$   
**C**  $1.25 \times 10^{-7} \text{ m}$   
**D**  $1.25 \times 10^{-5} \text{ m}$

- 283 A conductor consists of three wires connected in series. The wires are all made of the same metal but have different cross-sectional areas. There is a current  $I$  in the conductor. 9702/11/O/N/14/Q33

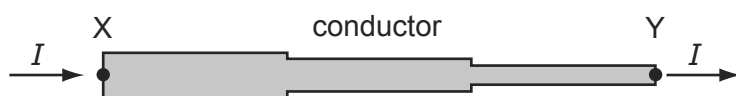

Point Y on the conductor is at zero potential.

Which graph best shows the variation of potential  $V$  with distance along the conductor?

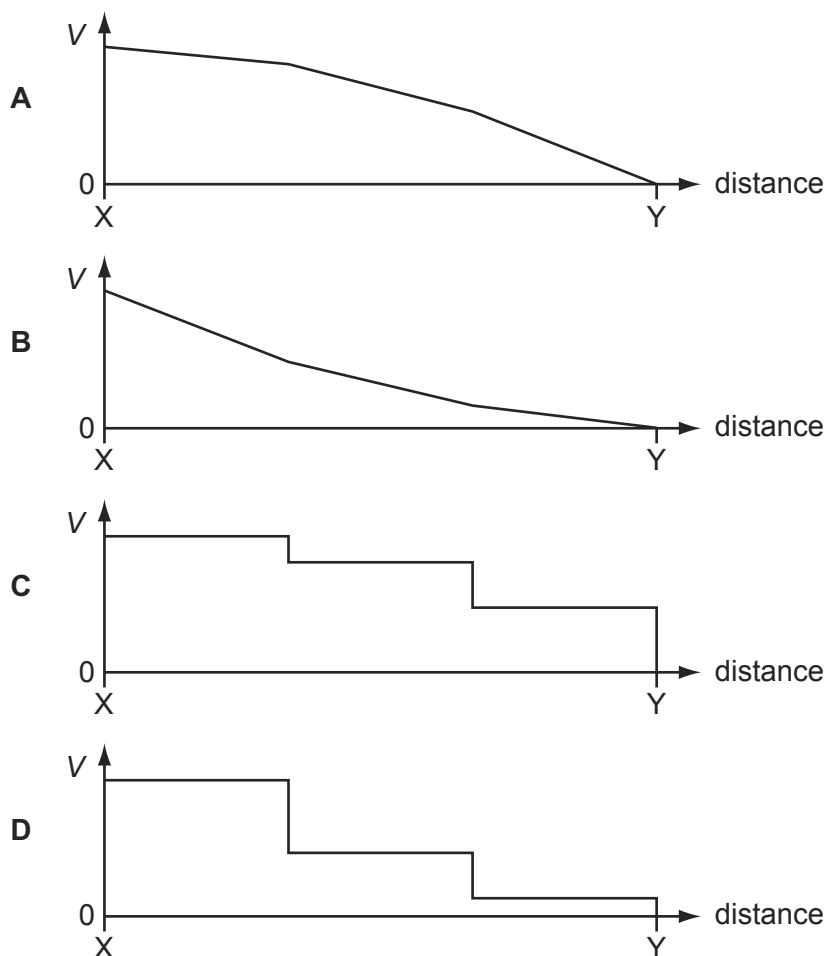

- 284 The graph shows how the electric current  $I$  through a conducting liquid varies with the potential difference  $V$  across it.

9702/11/O/N/14/Q34

At which point on the graph does the liquid have the smallest resistance?

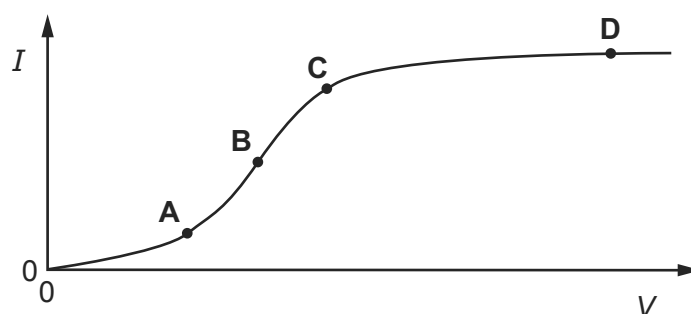

- 285 In the potentiometer circuit shown, the reading on the ammeter is zero.

9702/11/O/N/14/Q36

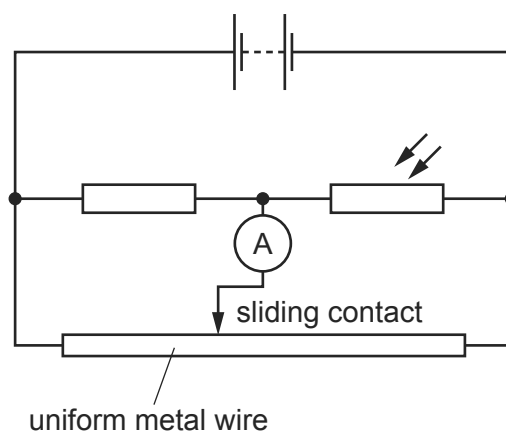

The light-dependent resistor (LDR) is then covered up and the ammeter gives a non-zero reading.

Which change could return the ammeter reading to zero?

- A** Decrease the supply voltage.
  - B** Increase the supply voltage.
  - C** Move the sliding contact to the left.
  - D** Move the sliding contact to the right.
- 286 A metal wire of length 0.50 m has a resistance of  $12\ \Omega$ .

9702/13/O/N/14/Q33

What is the resistance of a wire of length 2.0 m and made of the same material, but with half the diameter?

- A**  $12\ \Omega$
- B**  $48\ \Omega$
- C**  $96\ \Omega$
- D**  $192\ \Omega$

287 Six resistors, each of resistance  $R$ , are connected as shown.

9702/11/O/N/14/Q37

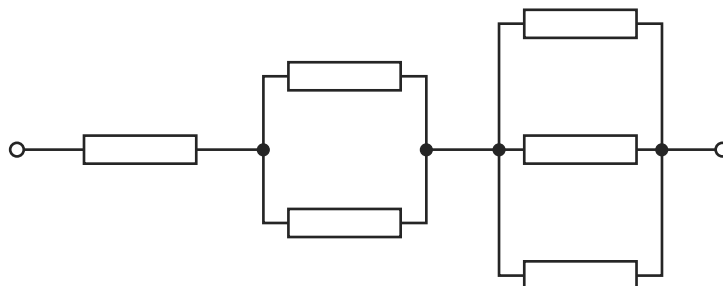

The combined resistance is  $66\text{ k}\Omega$ .

What is the value of  $R$ ?

- A**  $11\text{ k}\Omega$       **B**  $18\text{ k}\Omega$       **C**  $22\text{ k}\Omega$       **D**  $36\text{ k}\Omega$

288 A student found two unmarked resistors. To determine the resistance of the resistors, the circuit below was set up. The resistors were connected in turn between P and Q, noting the current readings. The voltage readings were noted without the resistors and with each resistor in turn.

9702/13/O/N/14/Q34

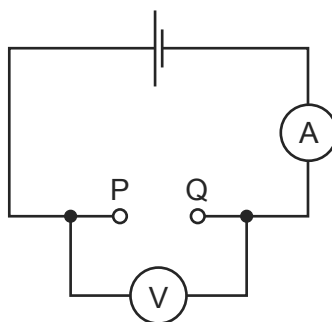

The results were entered into a spreadsheet as shown.

1.5	1.3	28	46
1.5	1.4	14	100

The student forgot to enter the column headings.

Which order of the headings would be correct?

- A**

e.m.f./V	V/V	$R/\Omega$	$I/\text{mA}$
----------	-----	------------	---------------
- B**

V/V	e.m.f./V	$R/\Omega$	$I/\text{mA}$
-----	----------	------------	---------------
- C**

V/V	e.m.f./V	$I/\text{mA}$	$R/\Omega$
-----	----------	---------------	------------
- D**

e.m.f./V	V/V	$I/\text{mA}$	$R/\Omega$
----------	-----	---------------	------------

- 289 A potential divider consists of resistors of resistance  $R_1$  and  $R_2$  connected in series across a source of potential difference  $V_0$ . The potential difference across  $R_1$  is  $V_{\text{out}}$ .

9702/13/O/N/14/Q35

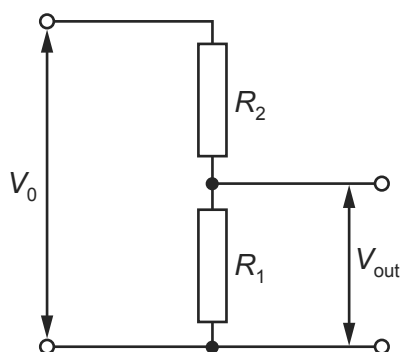

Which changes to  $R_1$  and  $R_2$  will increase the value of  $V_{\text{out}}$ ?

	$R_1$	$R_2$
<b>A</b>	doubled	doubled
<b>B</b>	doubled	halved
<b>C</b>	halved	doubled
<b>D</b>	halved	halved

- 290 In the circuit shown, the ammeters have negligible resistance and the voltmeters have infinite resistance.

9702/13/O/N/14/Q37

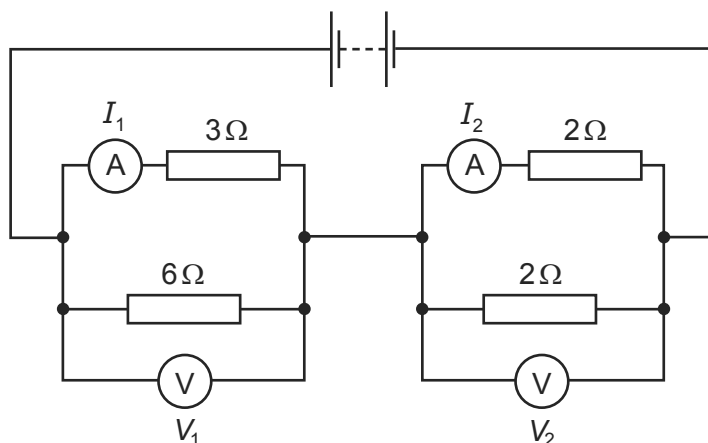

The readings on the meters are  $I_1$ ,  $I_2$ ,  $V_1$  and  $V_2$ , as labelled on the diagram.

Which statement is correct?

- A**  $I_1 > I_2$  and  $V_1 > V_2$   
**B**  $I_1 > I_2$  and  $V_1 < V_2$   
**C**  $I_1 < I_2$  and  $V_1 > V_2$   
**D**  $I_1 < I_2$  and  $V_1 < V_2$

- 291 An extension lead is used to connect a 240 V electrical supply to a heater as shown. 9702/13/O/N/14/Q36

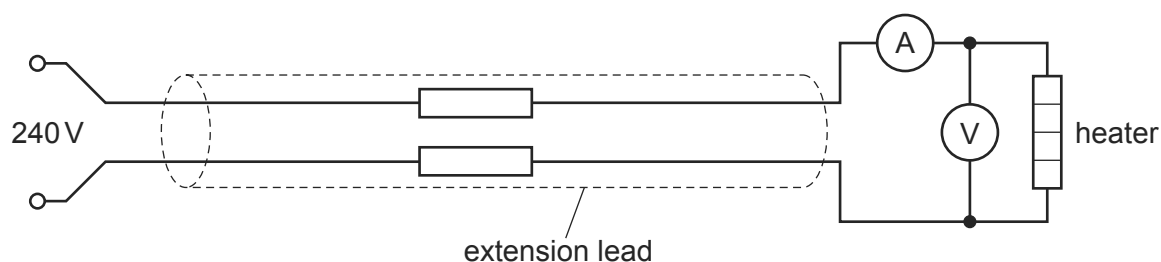

A voltmeter measures the potential difference (p.d.) across the heater as 216 V and an ammeter measures the current through the heater as 7.7 A.

What is the total resistance of the extension lead?

- A**  $3.1 \Omega$       **B**  $6.2 \Omega$       **C**  $28 \Omega$       **D**  $31 \Omega$
- 292 A pedal bicycle is fitted with an electric motor. The rider switches on the motor for a time of 3.0 minutes. A constant current of 3.5 A in the electric motor is provided from a battery with a terminal voltage of 24 V. 9702/13/M/J/15/Q32

What is the energy supplied by the battery?

- A** 84 J      **B** 250 J      **C** 630 J      **D** 15 000 J
- 293 The diagram shows a simple circuit. 9702/13/M/J/15/Q33

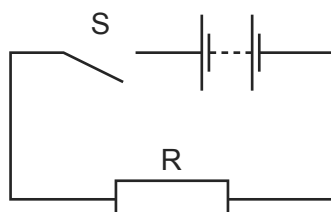

Which statement is correct?

- A** When switch S is closed, the electromotive force (e.m.f.) of the battery falls because work is done against the internal resistance of the battery.
- B** When switch S is closed, the e.m.f. of the battery falls because work is done against the resistance of R.
- C** When switch S is closed, the potential difference across the battery falls because work is done against the internal resistance of the battery.
- D** When switch S is closed, the potential difference across the battery falls because work is done against the resistance of R.



- 294 A simple circuit is formed by connecting a resistor of resistance  $R$  between the terminals of a battery of electromotive force (e.m.f.)  $9.0\text{V}$  and constant internal resistance  $r$ . 9702/13/M/J/15/Q34

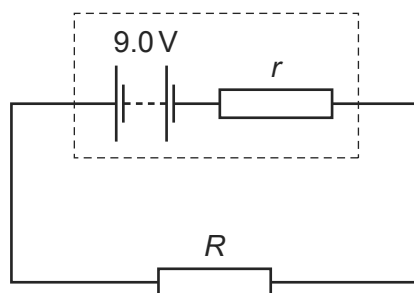

A charge of  $6.0\text{C}$  flows through the resistor in a time of  $2.0$  minutes causing it to dissipate  $48\text{J}$  of thermal energy.

What is the internal resistance  $r$  of the battery?

- A**  $0.17\ \Omega$       **B**  $0.33\ \Omega$       **C**  $20\ \Omega$       **D**  $160\ \Omega$
- 295 The diagram shows part of a current-carrying circuit. The ammeter has negligible resistance. 9702/13/M/J/15/Q37

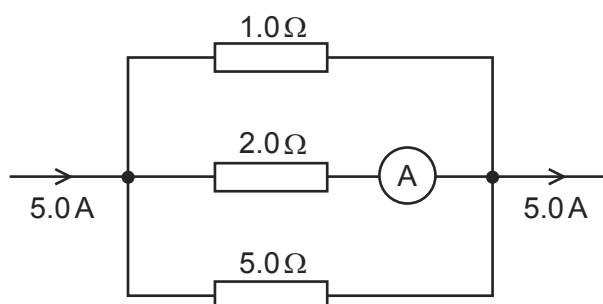

What is the reading on the ammeter?

- A**  $0.7\text{A}$       **B**  $1.3\text{A}$       **C**  $1.5\text{A}$       **D**  $1.7\text{A}$
- 296 Which statement is **not** valid? 9702/12/M/J/15/Q33

- A** Current is the speed of the charged particles that carry it.
- B** Electromotive force (e.m.f.) is the energy converted to electrical energy from other forms per unit charge.
- C** The potential difference (p.d.) between two points is the work done per unit charge when moving charge from one point to the other.
- D** The resistance between two points is the p.d. between the two points per unit current.

297 A box with four terminals P, Q, R and S contains two identical resistors.

9702/13/M/J/15/Q36

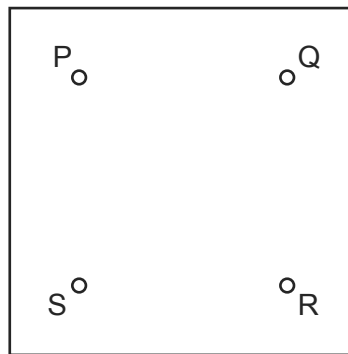

When a battery of electromotive force (e.m.f.)  $E$  and negligible internal resistance is connected across PS, a high-resistance voltmeter connected across QR reads  $\frac{E}{2}$ .

Which diagram shows the correct arrangement of the two resistors inside the box?

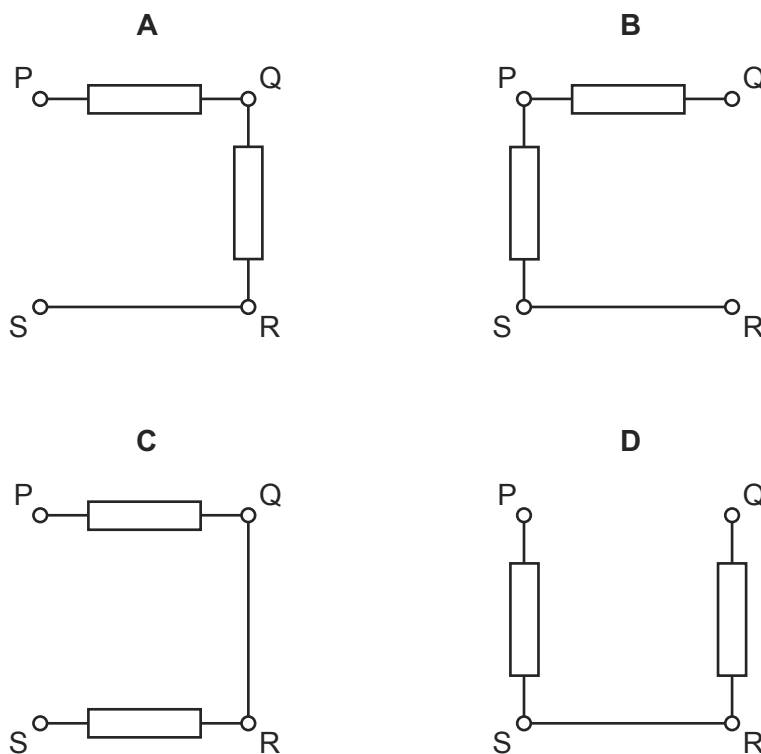

298 A source of e.m.f.  $9.0\text{ mV}$  has an internal resistance of  $6.0\ \Omega$ .

9702/13/M/J/15/Q35

It is connected across a galvanometer of resistance  $30\ \Omega$ .

What is the current in the galvanometer?

- A**  $250\ \mu\text{A}$       **B**  $300\ \mu\text{A}$       **C**  $1.5\ \text{mA}$       **D**  $2.5\ \text{mA}$

299 Which unit is **not** used in either the definition of the coulomb or the definition of the volt?

9702/12/M/J/15/Q31

- A ampere
- B joule
- C ohm
- D second

300 When a thin metal wire is stretched, it becomes longer and thinner. This causes a change in the resistance of the wire. The volume of the wire remains constant.

9702/12/M/J/15/Q32

Which graph could represent the variation with extension  $x$  of the resistance  $R$  of the wire?

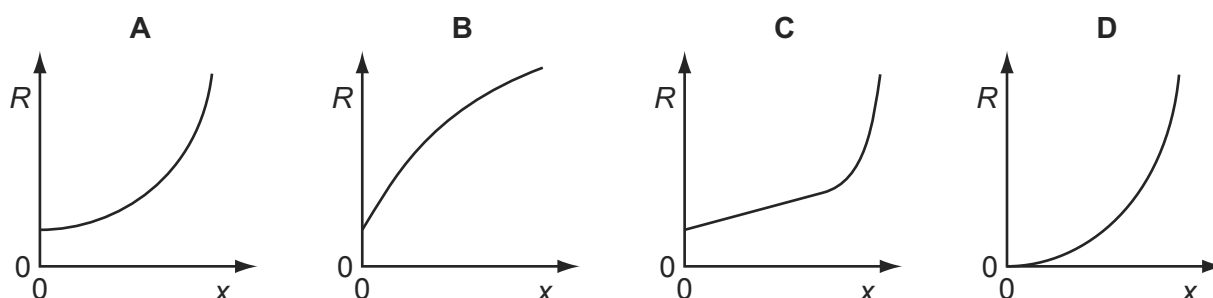

301 A cell of e.m.f.  $E$  delivers a charge  $Q$  to an external circuit.

9702/12/M/J/15/Q34

Which statement is correct?

- A The energy dissipation in the external circuit is  $EQ$ .
- B The energy dissipation within the cell is  $EQ$ .
- C The external resistance is  $EQ$ .
- D The total energy dissipation in the cell and the external circuit is  $EQ$ .

302 The diagrams show two different circuits.

9702/11/M/J/15/Q33

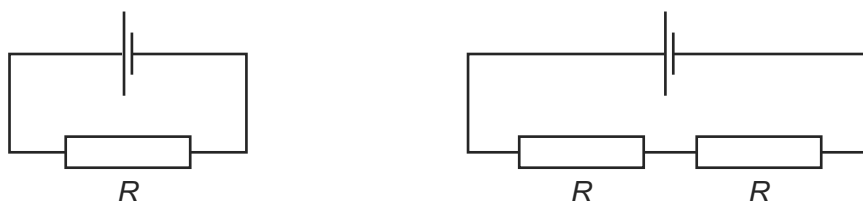

The cells in each circuit have the same electromotive force and zero internal resistance. The three resistors each have the same resistance  $R$ .

In the circuit on the left, the power dissipated in the resistor is  $P$ .

What is the total power dissipated in the circuit on the right?

- A  $\frac{P}{4}$
- B  $\frac{P}{2}$
- C  $P$
- D  $2P$

303 Each of Kirchhoff's two laws presumes that some quantity is conserved.

9702/12/M/J/15/Q35

Which row states Kirchhoff's **first** law and names the quantity that is conserved?

	statement	quantity
<b>A</b>	the algebraic sum of currents into a junction is zero	charge
<b>B</b>	the algebraic sum of currents into a junction is zero	energy
<b>C</b>	the e.m.f. in a loop is equal to the algebraic sum of the product of current and resistance round the loop	charge
<b>D</b>	the e.m.f. in a loop is equal to the algebraic sum of the product of current and resistance round the loop	energy

304 Which equation that links some of the following terms is correct?

9702/11/M/J/15/Q34

potential difference (p.d.)	$V$
current	$I$
resistance	$R$
charge	$Q$
energy	$E$
power	$P$
time	$t$

**A**  $P = \frac{Q^2 R}{t}$

**B**  $ER^2 = V^2 t$

**C**  $\frac{VI}{P} = t$

**D**  $PQ = EI$

- 305 A potential divider circuit consists of fixed resistors of resistance  $2.0\Omega$  and  $4.0\Omega$  connected in series with a  $3.0\Omega$  resistor fitted with a sliding contact. These are connected across a battery of e.m.f.  $9.0\text{V}$  and zero internal resistance, as shown.

9702/12/M/J/15/Q36

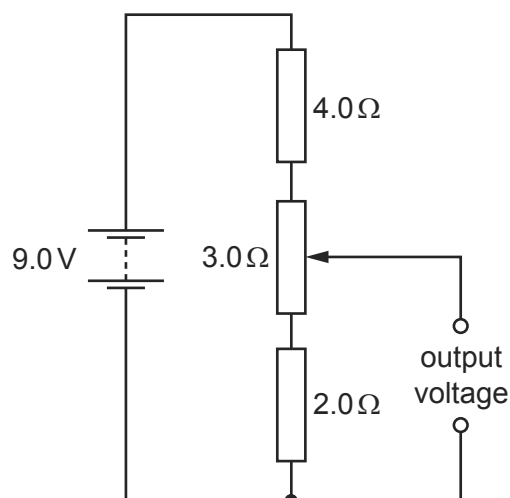

What are the maximum and the minimum output voltages of this potential divider circuit?

	maximum voltage /V	minimum voltage /V
<b>A</b>	4.0	2.0
<b>B</b>	5.0	2.0
<b>C</b>	9.0	0
<b>D</b>	9.0	2.0

- 306 A cell of e.m.f.  $2.0\text{V}$  and negligible internal resistance is connected to a network of resistors as shown.

9702/12/M/J/15/Q37

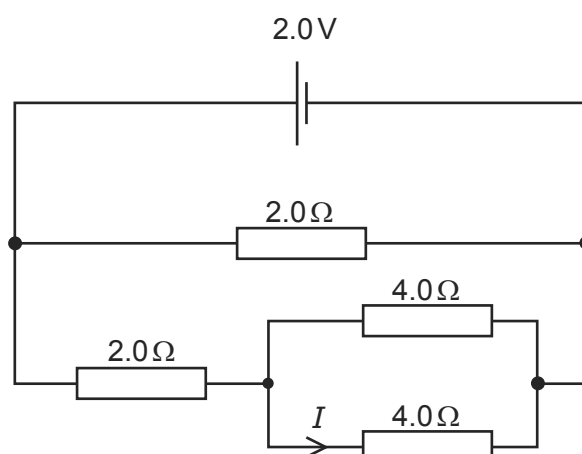

What is the current  $I$ ?

- A**  $0.25\text{A}$       **B**  $0.33\text{A}$       **C**  $0.50\text{A}$       **D**  $1.5\text{A}$

- 307 A battery with e.m.f.  $E$  and internal resistance  $r$  is connected in series with a variable external resistor.

9702/11/M/J/15/Q36

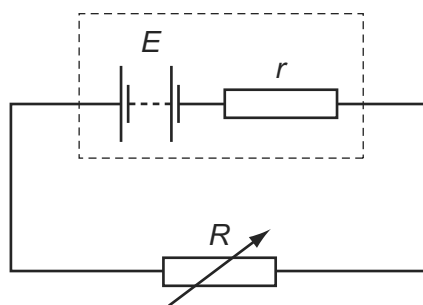

The value of the external resistance  $R$  is slowly increased from zero.

Which statement is correct? (Ignore any temperature effects.)

- A** The potential difference across the external resistance decreases.  
**B** The potential difference across the internal resistance increases.  
**C** The power dissipated in  $r$  increases and then decreases.  
**D** The power dissipated in  $R$  increases and then decreases.
- 308 A battery of electromotive force (e.m.f.)  $6.0\text{V}$  and negligible internal resistance is connected in series with a resistor of resistance  $6.0\Omega$  and a variable resistor of resistance from zero to  $4.0\Omega$ . A voltmeter is connected across the variable resistor. The resistance of the variable resistor is changed.

9702/11/M/J/15/Q37

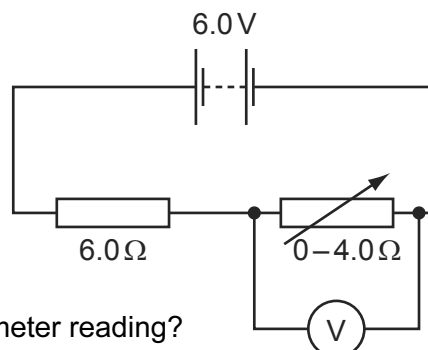

What is the range of the voltmeter reading?

- A**  $0\text{V} - 2.4\text{V}$   
**B**  $0\text{V} - 3.6\text{V}$   
**C**  $2.4\text{V} - 6.0\text{V}$   
**D**  $3.6\text{V} - 6.0\text{V}$
- 309 The charge that an electric battery can deliver is specified in ampere-hours.

9702/11/M/J/15/Q35

For example, a battery of capacity  $40$  ampere-hours could supply, when fully charged,  $0.2\text{A}$  for  $200$  hours.

What is the maximum energy that a fully charged  $12\text{V}$ ,  $40$  ampere-hour battery could supply?

- A**  $1.7\text{kJ}$       **B**  $29\text{kJ}$       **C**  $1.7\text{MJ}$       **D**  $29\text{MJ}$

310 A wire RST is connected to another wire XY as shown.

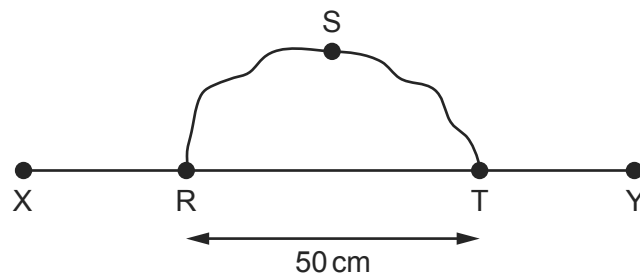

Each wire is 100 cm long with a resistance per unit length of  $10\ \Omega\ \text{m}^{-1}$ .

What is the total resistance between X and Y?

- A**  $3.3\ \Omega$       **B**  $5.0\ \Omega$       **C**  $8.3\ \Omega$       **D**  $13.3\ \Omega$

- 1 Which of the following summarises the change in wave characteristics on going from infra-red to ultraviolet in the electromagnetic spectrum?

9702/1/M/J/02/Q25

	frequency	speed (in a vacuum)
<b>A</b>	decreases	decreases
<b>B</b>	decreases	remains constant
<b>C</b>	increases	remains constant
<b>D</b>	increases	increases

- 2 The diagram shows a cathode-ray oscilloscope trace of a sound wave. The time-base is calibrated at  $2.0 \text{ ms cm}^{-1}$ .

9702/1/M/J/02/Q26

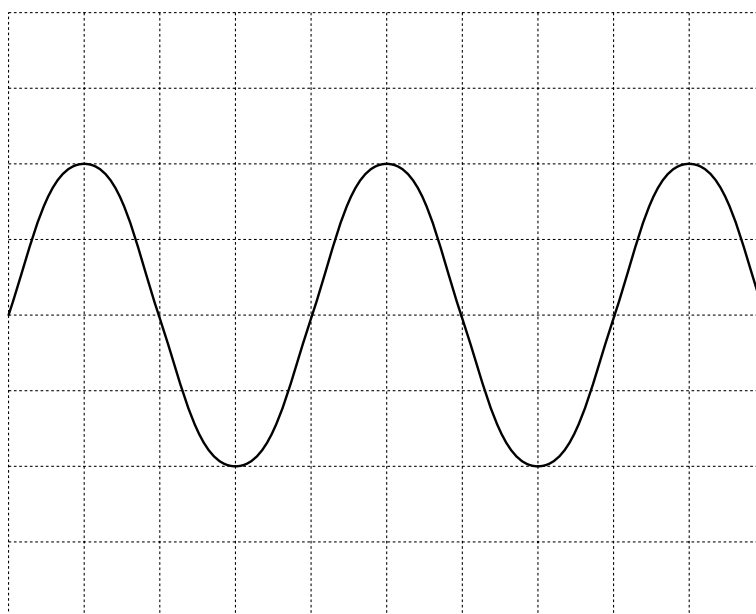

What is the frequency of the sound wave?

- A** 62.5 Hz      **B** 125 Hz      **C** 250 Hz      **D** 500 Hz
- 3 Which statement correctly relates the intensity of a sound wave to the vibrations of the molecules?

9702/1/M/J/02/Q27

- A** intensity  $\propto$  amplitude  
**B** intensity  $\propto$  (amplitude)<sup>2</sup>  
**C** intensity  $\propto$  displacement  
**D** intensity  $\propto$  (displacement)<sup>2</sup>



- 4 Which value is a possible wavelength for radiation in the microwave region of the electromagnetic spectrum?

9702/1/O/N/02/Q25

A  $3 \times 10^{-2} \text{ m}$       B  $3 \times 10^{-5} \text{ m}$       C  $3 \times 10^{-8} \text{ m}$       D  $3 \times 10^{-10} \text{ m}$

- 5 The four graphs represent a progressive wave on a stretched string. Graphs **A** and **B** show how the displacement  $d$  varies with distance  $x$  along the string at one instant. Graphs **C** and **D** show how the displacement  $d$  varies with time  $t$  at a particular value of  $x$ .

9702/1/O/N/02/Q26

The labels on the graphs are intended to show the wavelength  $\lambda$ , the period  $T$ , and the amplitude  $a$  of the wave, but only one graph is correctly labelled.

Which graph is correctly labelled?

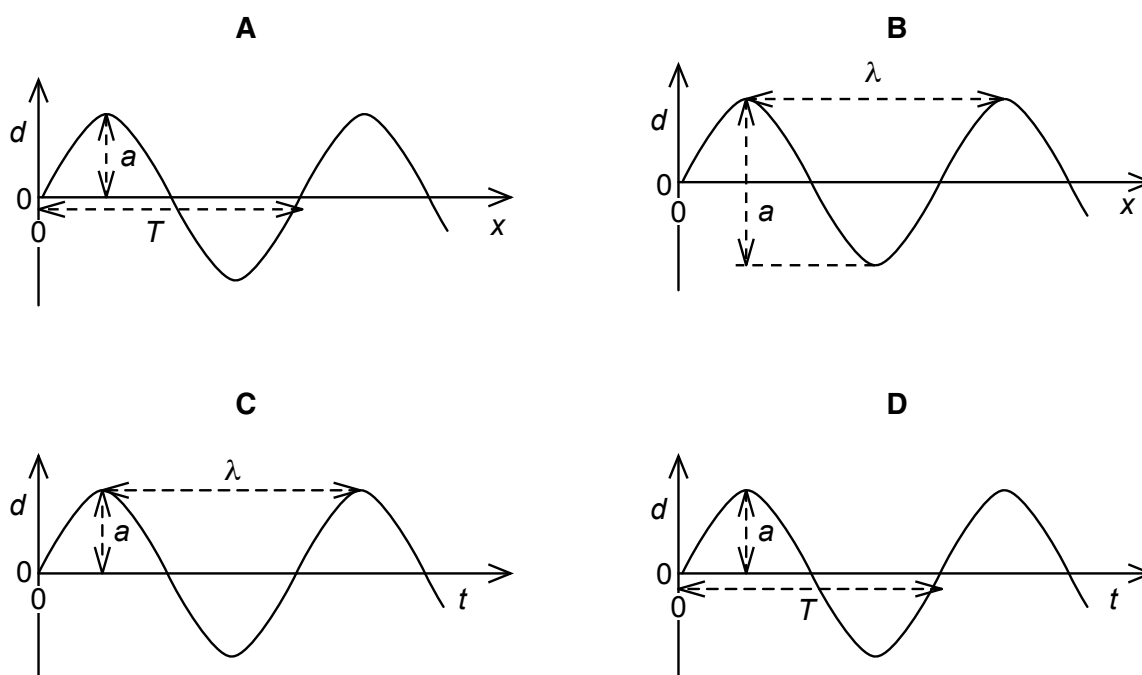

- 6 A wave of amplitude  $a$  has an intensity of  $3.0 \text{ Wm}^{-2}$ .

9702/1/O/N/02/Q27

What is the intensity of a wave of the same frequency that has an amplitude  $2a$ ?

A  $4.2 \text{ Wm}^{-2}$       B  $6.0 \text{ Wm}^{-2}$       C  $9.0 \text{ Wm}^{-2}$       D  $12 \text{ Wm}^{-2}$

- 7 Which of the following is true for all transverse waves?

9702/01/M/J/03/Q23

- A They are all electromagnetic.  
 B They can all be polarised.  
 C They can all travel through a vacuum.  
 D They all involve the oscillation of atoms.

- 8 Electromagnetic waves of wavelength  $\lambda$  and frequency  $f$  travel at speed  $c$  in a vacuum.

Which of the following describes the wavelength and speed of electromagnetic waves of frequency  $f/2$ ?

9702/01/M/J/03/Q25

	wavelength	speed in a vacuum
<b>A</b>	$\lambda/2$	$c/2$
<b>B</b>	$\lambda/2$	$c$
<b>C</b>	$2\lambda$	$c$
<b>D</b>	$2\lambda$	$2c$

- 9 A sound wave is displayed on the screen of a cathode-ray oscilloscope. The time base of the c.r.o. is set at  $2.5 \text{ ms/cm}$ .

9702/01/M/J/03/Q26

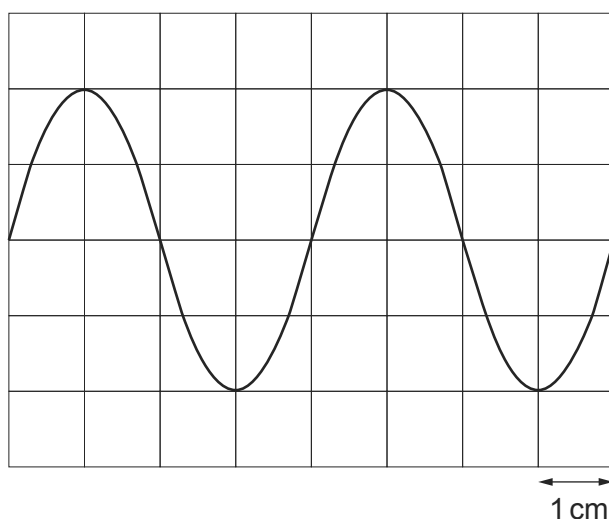

What is the frequency of the sound wave?

- A** 50 Hz      **B** 100 Hz      **C** 200 Hz      **D** 400 Hz
- 10 When the light from two lamps falls on a screen, no interference pattern can be obtained.

9702/01/M/J/03/Q27

Why is this?

- A** The lamps are not point sources.  
**B** The lamps emit light of different amplitudes.  
**C** The light from the lamps is not coherent.  
**D** The light from the lamps is white.

- 11 The graph shows how the displacement of a particle in a wave varies with time.

9702/01/O/N/03/Q23

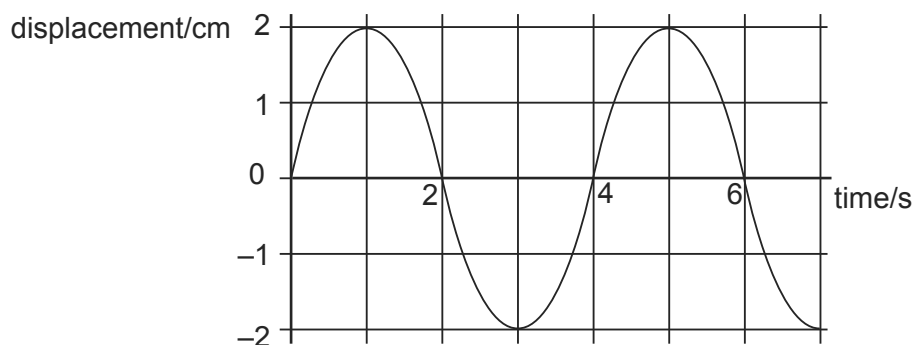

Which of the following is correct?

- A** The wave has an amplitude of 2 cm and could be either transverse or longitudinal.  
**B** The wave has an amplitude of 2 cm and must be transverse.  
**C** The wave has an amplitude of 4 cm and could be either transverse or longitudinal.  
**D** The wave has an amplitude of 4 cm and must be transverse.
- 12 Which of the following applies to a progressive transverse wave?

9702/01/O/N/03/Q25

	transfers energy	can be polarised
<b>A</b>	no	no
<b>B</b>	no	yes
<b>C</b>	yes	no
<b>D</b>	yes	yes

- 13 Which observation indicates that sound waves are longitudinal?

9702/01/M/J/04/Q24

- A** Sound can be reflected from a solid surface.  
**B** Sound cannot be polarised.  
**C** Sound is diffracted around corners.  
**D** Sound is refracted as it passes from hot air to cold air.

- 14 The diagram shows a transverse wave on a rope. The wave is travelling from left to right.

At the instant shown, the points P and Q on the rope have zero displacement and maximum displacement respectively.

9702/01/M/J/04/Q25

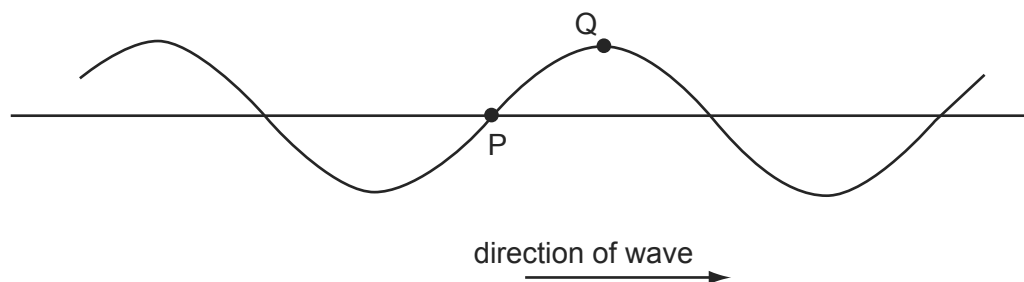

Which of the following describes the direction of motion, if any, of the points P and Q at this instant?

	point P	point Q
<b>A</b>	downwards	stationary
<b>B</b>	stationary	downwards
<b>C</b>	stationary	upwards
<b>D</b>	upwards	stationary

- 15 A plane wave of amplitude  $A$  is incident on a surface of area  $S$  placed so that it is perpendicular to the direction of travel of the wave. The energy per unit time reaching the surface is  $E$ .

The amplitude of the wave is increased to  $2A$  and the area of the surface is reduced to  $\frac{1}{2}S$ .

How much energy per unit time reaches this smaller surface?

9702/01/M/J/04/Q26

- A**  $4E$                       **B**  $2E$                       **C**  $E$                       **D**  $\frac{1}{2}E$

- 16 What is the approximate range of frequencies of infra-red radiation?

9702/01/M/J/04/Q27

- A**  $1 \times 10^3$  Hz    to     $1 \times 10^9$  Hz  
**B**  $1 \times 10^9$  Hz    to     $1 \times 10^{11}$  Hz  
**C**  $1 \times 10^{11}$  Hz    to     $1 \times 10^{14}$  Hz  
**D**  $1 \times 10^{14}$  Hz    to     $1 \times 10^{17}$  Hz

- 17 A wave of amplitude 20 mm has intensity  $I_X$ . Another wave of the same frequency but of amplitude 5 mm has intensity  $I_Y$ .

9702/01/O/N/04/Q26

What is  $\frac{I_X}{I_Y}$ ?

- A** 2                      **B** 4                      **C** 16                      **D** 256

- 18 Which of the following is a longitudinal wave? 9702/01/O/N/04/Q24
- A** a light wave travelling through air  
**B** a radio wave from a broadcasting station  
**C** a ripple on the surface of water  
**D** a sound wave travelling through air
- 19 What do **not** travel at the speed of light in a vacuum? 9702/01/M/J/05/Q23
- A** electrons  
**B** microwaves  
**C** radio waves  
**D** X-rays
- 20 The number of wavelengths of visible light in one metre is of the order of 9702/01/M/J/05/Q24
- A**  $10^4$ .      **B**  $10^6$ .      **C**  $10^8$ .      **D**  $10^{10}$ .
- 21 A health inspector is measuring the intensity of a sound. Near a loudspeaker his meter records an intensity  $I$ . This corresponds to an amplitude  $A$  of the sound wave. At another position the meter gives an intensity reading of  $2I$ . 9702/01/M/J/0/Q25
- What is the corresponding sound wave amplitude?
- A**  $\frac{A}{\sqrt{2}}$       **B**  $\sqrt{2}A$       **C**  $2A$       **D**  $4A$
- 22 A sound wave is set up in a long tube, closed at one end. The length of the tube is adjusted until the sound from the tube is loudest. 9702/01/M/J/0/Q26
- What is the nature of the sound wave in the tube?
- A** longitudinal and progressive  
**B** longitudinal and stationary  
**C** transverse and progressive  
**D** transverse and stationary
- 23 The frequency of a certain wave is 500 Hz and its speed is  $340 \text{ m s}^{-1}$ . 9702/01/M/J/06/Q25
- What is the phase difference between the motions of two points on the wave 0.17 m apart?
- A**  $\frac{\pi}{4}$  rad      **B**  $\frac{\pi}{2}$  rad      **C**  $\frac{3\pi}{4}$  rad      **D**  $\pi$  rad

- 24 Polarisation is a phenomenon associated with a certain type of wave.

9702/01/O/N/0/Q22

Which condition **must** be fulfilled if a wave is to be polarised?

- A** It must be a light wave.  
**B** It must be a longitudinal wave.  
**C** It must be a radio wave.  
**D** It must be a transverse wave.
- 25 A sound wave has displacement  $y$  at distance  $x$  from its source at time  $t$ .

9702/01/O/N/0/Q23

Which graph correctly shows the amplitude  $a$  and the wavelength  $\lambda$  of the wave?

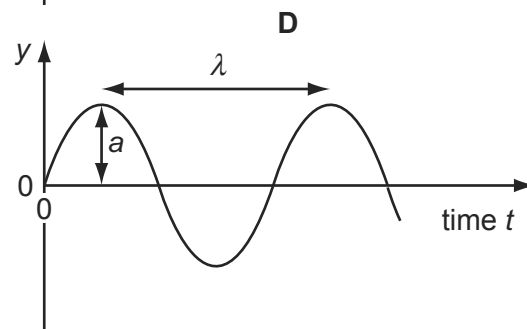
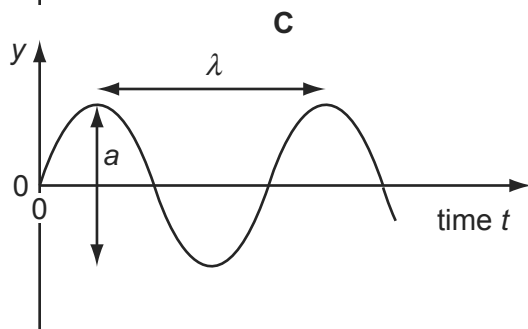
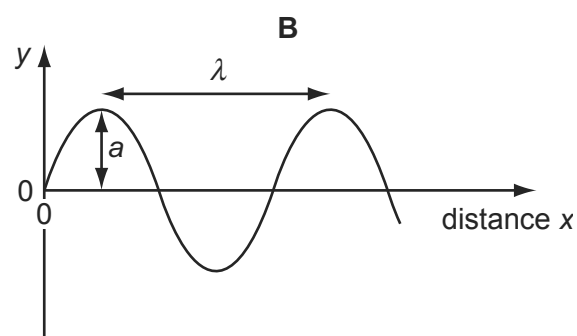
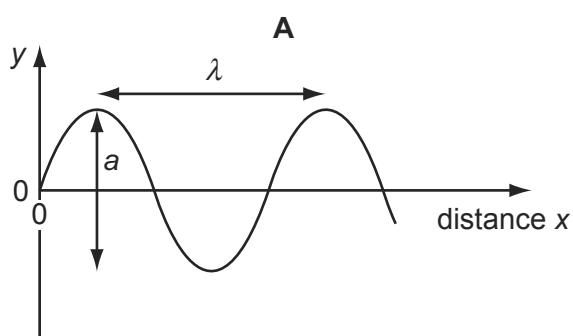

- 26 Which phenomenon is associated with transverse waves but **not** longitudinal waves?

9702/01/M/J/06/Q23

- A** polarisation  
**B** reflection  
**C** refraction  
**D** superposition
- 27 The order of magnitude of the frequency of the longest-wavelength ultraviolet waves can be expressed as  $10^x$  Hz.

9702/11/O/N/09/Q23

What is the value of  $x$ ?

- A** 13                      **B** 15                      **C** 17                      **D** 19

- 28 The intensity of a progressive wave is proportional to the square of the amplitude of the wave. It is also proportional to the square of the frequency. 9702/01/O/N/05/Q24

The variation with time  $t$  of displacement  $x$  of particles in a medium, when two progressive waves P and Q pass separately through the medium, are shown on the graphs.

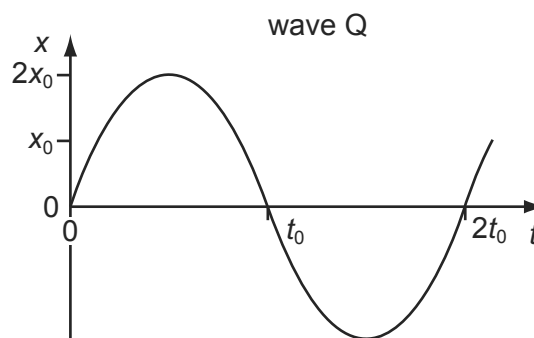
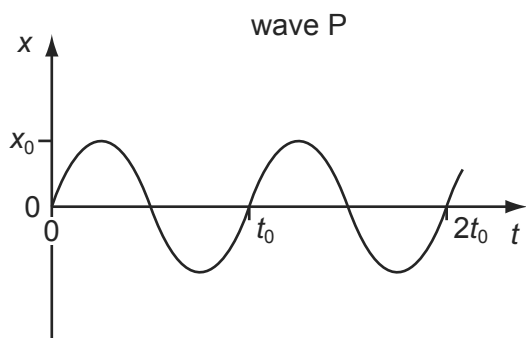

The intensity of wave P is  $I_0$ .

What is the intensity of wave Q?

- A**  $\frac{1}{2}I_0$       **B**  $I_0$       **C**  $8I_0$       **D**  $16I_0$
- 29 A sound wave of frequency  $150 \text{ Hz}$  travels in water at a speed of  $1500 \text{ m s}^{-1}$ . It then travels through the surface of the water and into air, where its speed is  $300 \text{ m s}^{-1}$ . 9702/01/O/N/05/Q25

Which line in the table gives the correct values for the wavelengths of the sound in water and in air?

	wavelength in water / m	wavelength in air / m
<b>A</b>	0.10	0.10
<b>B</b>	0.10	0.50
<b>C</b>	10	2.0
<b>D</b>	10	50

- 30 A wave motion is described by the oscillation of particles. 9702/01/O/N/06/Q24

What is the name given to the number of complete oscillations of a particle in one second?

- A** amplitude  
**B** frequency  
**C** wavelength  
**D** wave speed

31 A displacement-time graph is shown for a particular wave.

9702/01/M/J/06/Q24

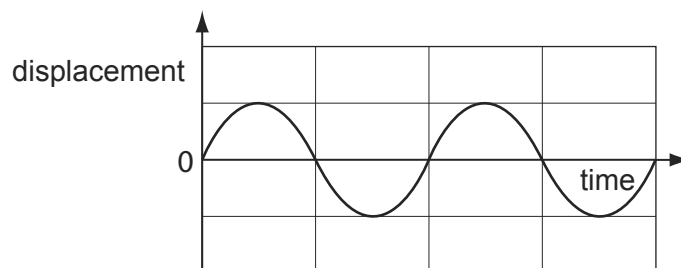

A second wave of similar type has twice the intensity and half the frequency.

When drawn on the same axes, what would the second wave look like?

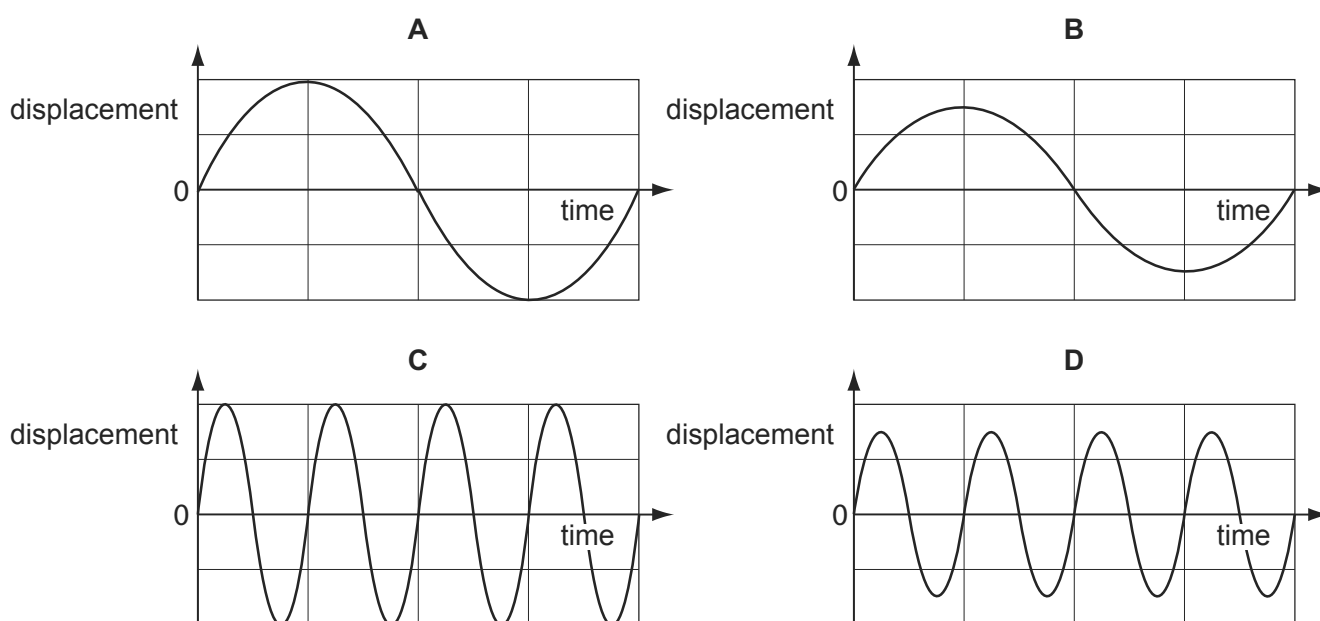

32 A displacement-time graph for a transverse wave is shown in the diagram.

9702/01/O/N/06/Q25

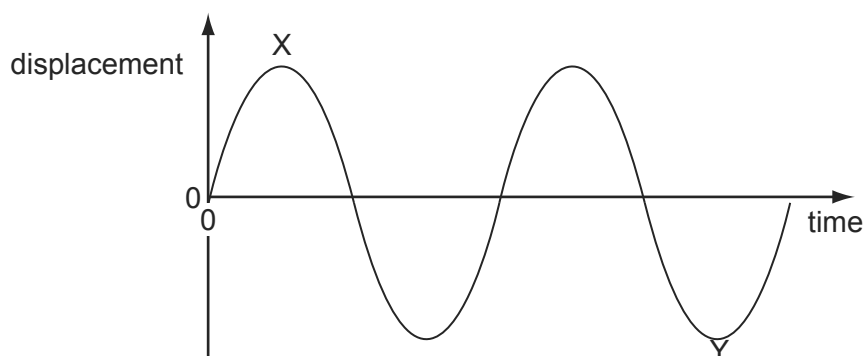

The phase difference between X and Y can be expressed as  $n\pi$ .

What is the value of  $n$ ?

- A** 1.5      **B** 2.5      **C** 3.0      **D** 6.0



- 33 Continuous water waves are diffracted through a gap in a barrier in a ripple tank. 9702/01/O/N/06/Q26

Which change will cause the diffraction of the waves to increase?

- A increasing the frequency of the waves
  - B increasing the width of the gap
  - C reducing the wavelength of the waves
  - D reducing the width of the gap
- 34 Which of the following types of wave can be polarised? 9702/01/M/J/07/Q21
- A a longitudinal progressive wave
  - B a longitudinal stationary wave
  - C a transverse stationary wave
  - D a transverse sound wave
- 35 Sound wave X has intensity  $10^{12}$  times greater than that of sound wave Y. 9702/01/M/J/07/Q22
- By how much is the amplitude of X greater than the amplitude of Y?
- A  $10^6$  times
  - B  $3.16 \times 10^6$  times
  - C  $5 \times 10^{11}$  times
  - D  $10^{12}$  times

- 36 The graph shows the shape at a particular instant of part of a transverse wave travelling along a string. 9702/01/M/J/07/Q23

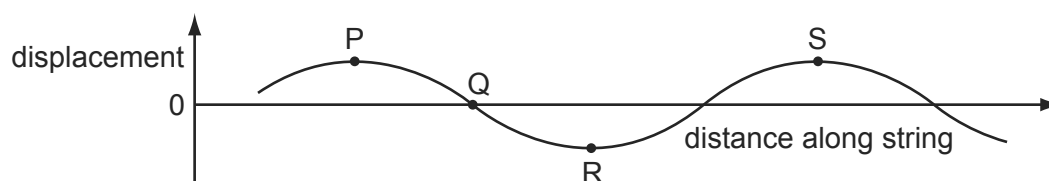

Which statement about the motion of points in the string is correct?

- A The speed at point P is a maximum.
- B The displacement at point Q is always zero.
- C The energy at point R is entirely kinetic.
- D The acceleration at point S is a maximum.

37 The diagram illustrates part of the electromagnetic spectrum.

9702/01/M/J/07/Q24

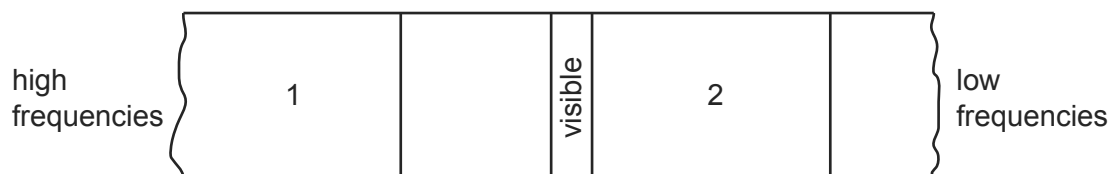

Which labels are correct for the regions marked 1 and 2?

	1	2
<b>A</b>	infrared	X-rays
<b>B</b>	microwaves	X-rays
<b>C</b>	ultraviolet	microwaves
<b>D</b>	X-rays	infrared

38 What is the relationship between the intensity  $I$  and the amplitude  $a$  of a wave?

9702/01/O/N/07/Q21

- A**  $\frac{I}{a} = \text{constant}$
- B**  $\frac{I}{a^2} = \text{constant}$
- C**  $Ia = \text{constant}$
- D**  $Ia^2 = \text{constant}$

39 The graph represents a sinusoidal wave in the sea, travelling at a speed of  $8.0 \text{ m s}^{-1}$ , at one instant of time. The maximum speed of the oscillating particles in the wave is  $2\pi af$ , where  $a$  is the amplitude and  $f$  is the frequency.

9702/01/O/N/07/Q23

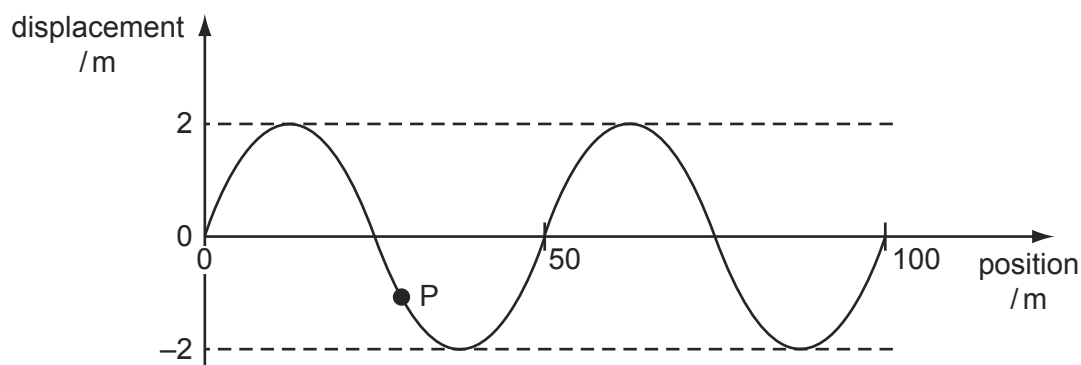

An object P of mass  $2.0 \times 10^{-3} \text{ kg}$  floats on the surface.

What is the maximum kinetic energy of P due to the wave? Assume that its motion is vertical.

- A** 0.026 mJ      **B** 4.0 mJ      **C** 39 mJ      **D** 64 mJ

- 40 An electromagnetic wave has a frequency of  $10^8$  Hz.

9702/01/O/N/07/Q22

In which region of the electromagnetic spectrum does the wave occur?

- A infra-red  
 B radio  
 C ultraviolet  
 D visible

- 41 The graph shows how the height of a water surface at a point in a harbour varies with time  $t$  as waves pass the point.

9702/01/M/J/08/Q25

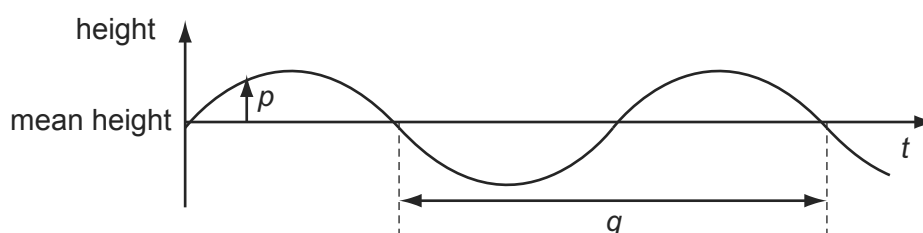

What are  $p$  and  $q$ ?

	$p$	$q$
A	displacement	wavelength
B	displacement	period
C	amplitude	wavelength
D	amplitude	period

- 42 The intensity  $I$  of a sound at a point P is inversely proportional to the square of the distance  $x$  of P from the source of the sound. That is

9702/01/M/J/08/Q26

$$I \propto \frac{1}{x^2}.$$

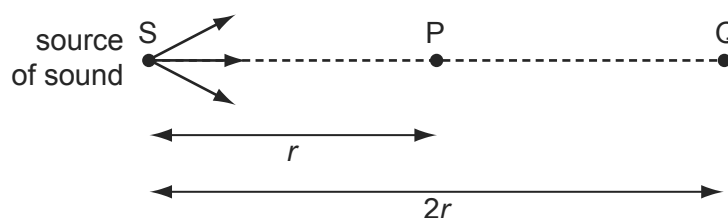

Air molecules at P, a distance  $r$  from S, oscillate with amplitude  $8.0 \mu\text{m}$ .

Point Q is situated a distance  $2r$  from S.

What is the amplitude of oscillation of air molecules at Q?

- A  $1.4 \mu\text{m}$       B  $2.0 \mu\text{m}$       C  $2.8 \mu\text{m}$       D  $4.0 \mu\text{m}$

- 43 Sound waves, emitted by a small loudspeaker, are reflected by a wall.

9702/01/M/J/08/Q27

The frequency  $f$  of the waves is adjusted until a stationary wave is formed with the antinode nearest the wall at a distance  $x$  from the wall.

Which expression gives  $f$  in terms of  $x$  and the speed of sound  $c$ ?

- A**  $f = \frac{4c}{x}$       **B**  $f = \frac{2c}{x}$       **C**  $f = \frac{c}{2x}$       **D**  $f = \frac{c}{4x}$

- 44 The diagram shows two waves X and Y.

9702/01/O/N/08/Q24

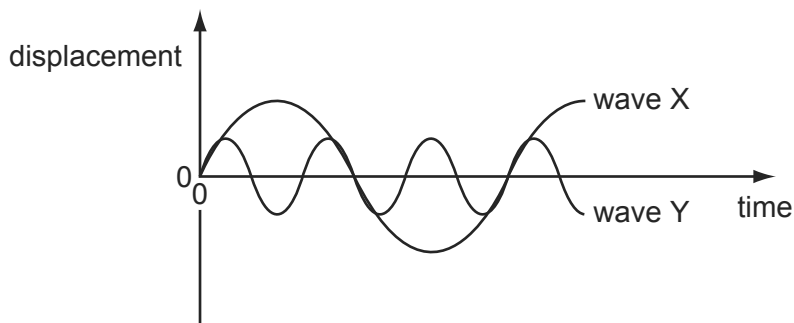

Wave X has amplitude 8 cm and frequency 100 Hz.

What are the amplitude and frequency of wave Y?

	amplitude/cm	frequency/Hz
<b>A</b>	2	33
<b>B</b>	2	300
<b>C</b>	4	33
<b>D</b>	4	300

- 45 Light can exhibit all of the properties listed.

9702/01/O/N/08/Q25

Which property can sound **not** exhibit?

- A** interference  
**B** polarisation  
**C** refraction  
**D** total internal reflection
- 46 The order of magnitude of the frequency of the longest-wavelength ultraviolet waves can be expressed as  $10^x$  Hz.

9702/12/O/N/09/Q22

What is the value of  $x$ ?

- A** 13      **B** 15      **C** 17      **D** 19

- 47 The diagram represents the screen of a cathode-ray oscilloscope displaying two sound waves labelled X and Y.

9702/01/O/N/08/Q26

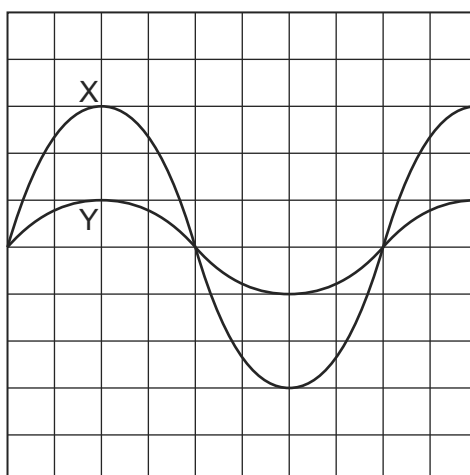

What is the ratio  $\frac{\text{intensity of sound wave X}}{\text{intensity of sound wave Y}}$  ?

- A  $\frac{9}{1}$                       B  $\frac{3}{1}$                       C  $\frac{\sqrt{3}}{1}$                       D  $\frac{1}{1}$

- 48 Which wave properties change when light passes from air into glass?

9702/01/M/J/09/Q23

- A colour and speed  
 B frequency and wavelength  
 C speed and wavelength  
 D wavelength and colour

- 49 The light from two lasers passes through a vacuum. One laser emits red light and the other emits green light.

9702/11/O/N/09/Q24

Which property of the two laser beams must be different?

- A amplitude  
 B frequency  
 C plane of polarisation  
 D speed

- 50 The amplitude of a wave is  $A$  and its intensity is  $I$ .

9702/12/O/N/10/Q23

Which amplitude is necessary for the intensity to be doubled to  $2I$ ?

- A  $A^2$                       B  $\sqrt{A}$                       C  $\sqrt{2}A$                       D  $2A$

- 51 The light from two lasers passes through a vacuum. One laser emits red light and the other emits green light. 9702/12/O/N/09/Q23

Which property of the two laser beams must be different?

- A amplitude
  - B frequency
  - C plane of polarisation
  - D speed
- 52 Electromagnetic waves from an unknown source in space were found to be significantly diffracted when passing through gaps of the order of  $10^{-5}$  m. 9702/11/M/J/10/Q22

Which type of wave are they most likely to be?

- A radio waves
  - B microwaves
  - C infra-red waves
  - D ultraviolet waves
- 53 Electromagnetic waves from an unknown source in space were found to be significantly diffracted when passing through gaps of the order of  $10^{-5}$  m. 9702/13/M/J/10/Q23

Which type of wave are they most likely to be?

- A radio waves
  - B microwaves
  - C infra-red waves
  - D ultraviolet waves
- 54 Electromagnetic waves from an unknown source in space were found to be significantly diffracted when passing through gaps of the order of  $10^{-5}$  m. 9702/12/M/J/10/Q24

Which type of wave are they most likely to be?

- A radio waves
  - B microwaves
  - C infra-red waves
  - D ultraviolet waves
- 55 Which value is a possible wavelength for radiation in the ultra-violet region of the electromagnetic spectrum? 9702/12/O/N/10/Q24

- A  $3 \times 10^{-2}$  m      B  $3 \times 10^{-5}$  m      C  $3 \times 10^{-8}$  m      D  $3 \times 10^{-10}$  m

56 The graph shows how the displacement of a particle in a wave varies with time.

9702/11/O/N/10/Q23

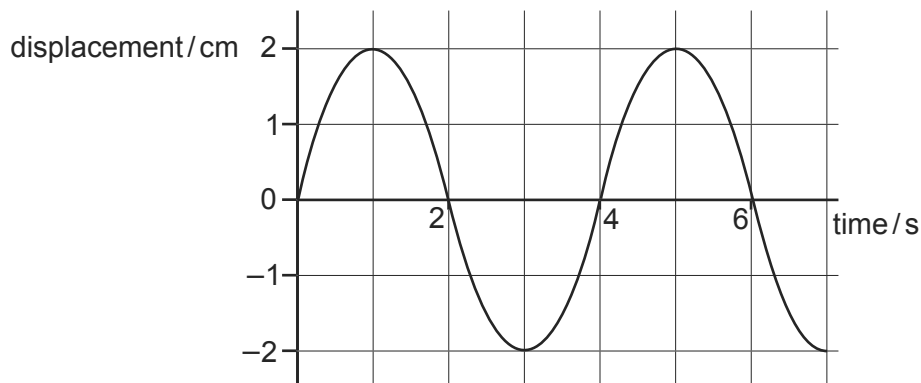

Which statement is correct?

- A The wave has an amplitude of 2 cm and could be either transverse or longitudinal.
- B The wave has an amplitude of 2 cm and must be transverse.
- C The wave has an amplitude of 4 cm and could be either transverse or longitudinal.
- D The wave has an amplitude of 4 cm and must be transverse.

57 The diagram shows a vertical cross-section through a water wave moving from left to right.

9702/11/O/N/10/Q24

At which point is the water moving upwards with maximum speed?

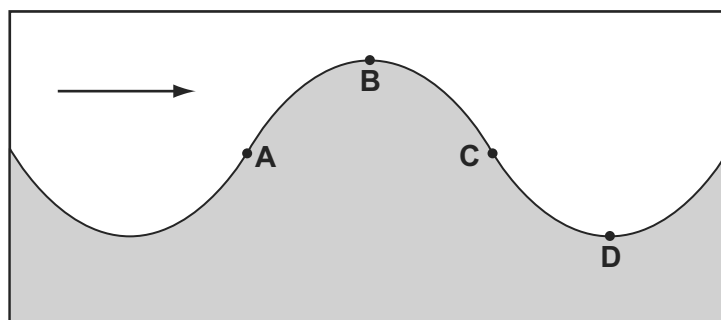

58 A stationary wave is produced by two loudspeakers emitting sound of the same frequency.

9702/11/O/N/10/Q26

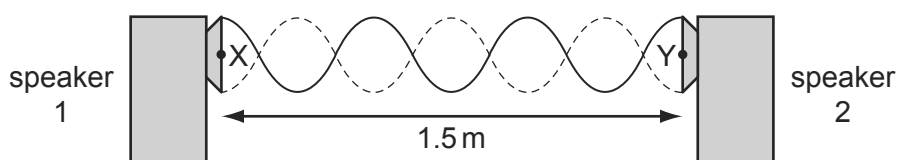

When a microphone is moved between X and Y, a distance of 1.5 m, six nodes and seven antinodes are detected.

What is the wavelength of the sound?

- A 0.50 m
- B 0.43 m
- C 0.25 m
- D 0.21 m

- 59 When plane-polarised light of amplitude  $a$  is passed through a polarising filter as shown, the amplitude of the light emerging is  $a \cos \theta$ . 9702/11/O/N/10/Q25

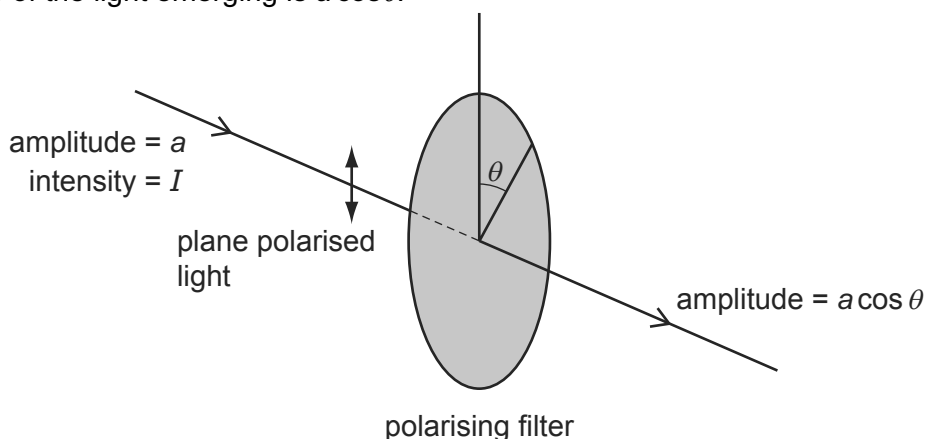

The intensity of the initial beam is  $I$ .

What is the intensity of the emerging light when  $\theta$  is  $60.0^\circ$ ?

- A**  $0.250I$       **B**  $0.500I$       **C**  $0.750I$       **D**  $0.866I$
- 60 When plane-polarised light of amplitude  $a$  is passed through a polarising filter as shown, the amplitude of the light emerging is  $a \cos \theta$ . 9702/13/O/N/10/Q24

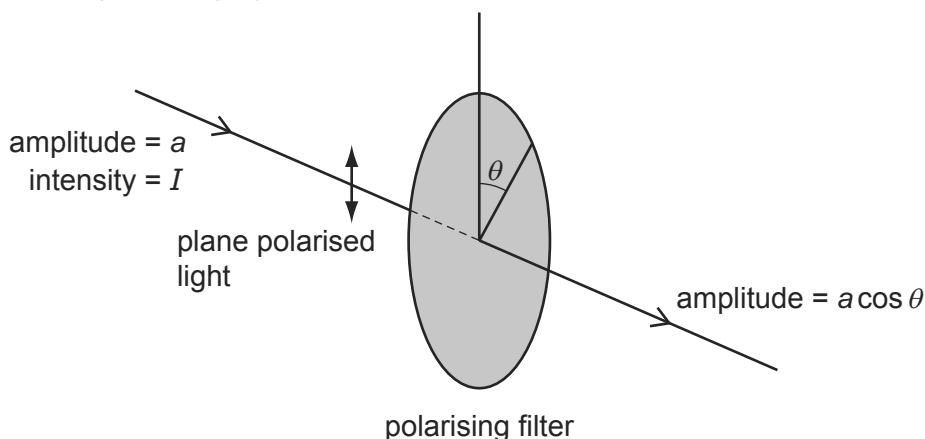

The intensity of the initial beam is  $I$ .

What is the intensity of the emerging light when  $\theta$  is  $60.0^\circ$ ?

- A**  $0.250I$       **B**  $0.500I$       **C**  $0.750I$       **D**  $0.866I$
- 61 Which electromagnetic wave would cause the most significant diffraction effect for an atomic lattice of spacing around  $10^{-10}$  m? 9702/13/O/N/10/Q26

- A** infra-red  
**B** microwave  
**C** ultraviolet  
**D** X-ray



- 62 The diagram shows a vertical cross-section through a water wave moving from left to right.

9702/13/O/N/10/Q25

At which point is the water moving upwards with maximum speed?

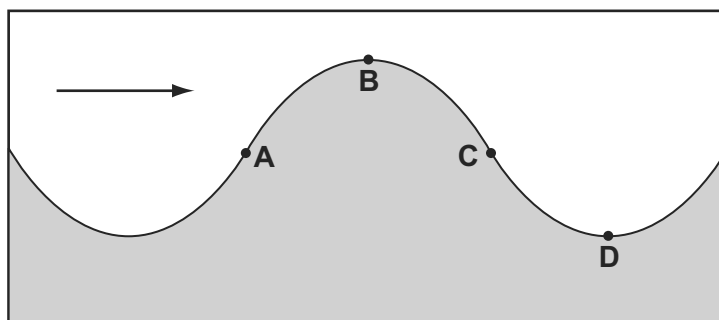

- 63 The graph shows how the displacement of a particle in a wave varies with time.

9702/13/O/N/10/Q27

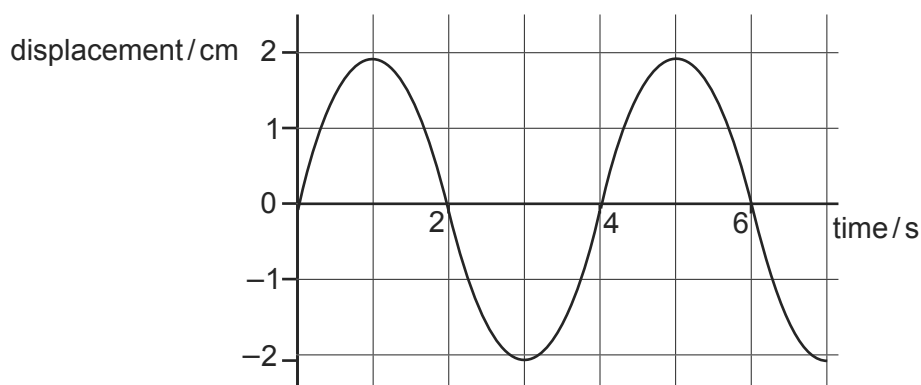

Which statement is correct?

- A** The wave has an amplitude of 2 cm and could be either transverse or longitudinal.  
**B** The wave has an amplitude of 2 cm and must be transverse.  
**C** The wave has an amplitude of 4 cm and could be either transverse or longitudinal.  
**D** The wave has an amplitude of 4 cm and must be transverse.
- 64 Which statement about sound waves in air at constant temperature is correct?
- A** Amplitude is inversely proportional to velocity.  
**B** Frequency is inversely proportional to wavelength.  
**C** Velocity is proportional to wavelength.  
**D** Wavelength is proportional to amplitude.

9702/11/M/J/11/Q23

- 65 In which order of magnitude are the frequencies of electromagnetic waves in the visible spectrum?

9702/12/M/J/11/Q25

- A**  $10^{12}$  Hz      **B**  $10^{13}$  Hz      **C**  $10^{14}$  Hz      **D**  $10^{15}$  Hz

- 66 The four graphs represent a progressive wave on a stretched string. Graphs **A** and **B** show how the displacement  $d$  varies with distance  $x$  along the string at one instant. Graphs **C** and **D** show how the displacement  $d$  varies with time  $t$  at a particular value of  $x$ .

9702/11/M/J/11/Q22

The labels on the graphs are intended to show the wavelength  $\lambda$ , the period  $T$  and the amplitude  $a$  of the wave, but only one graph is correctly labelled.

Which graph is correctly labelled?

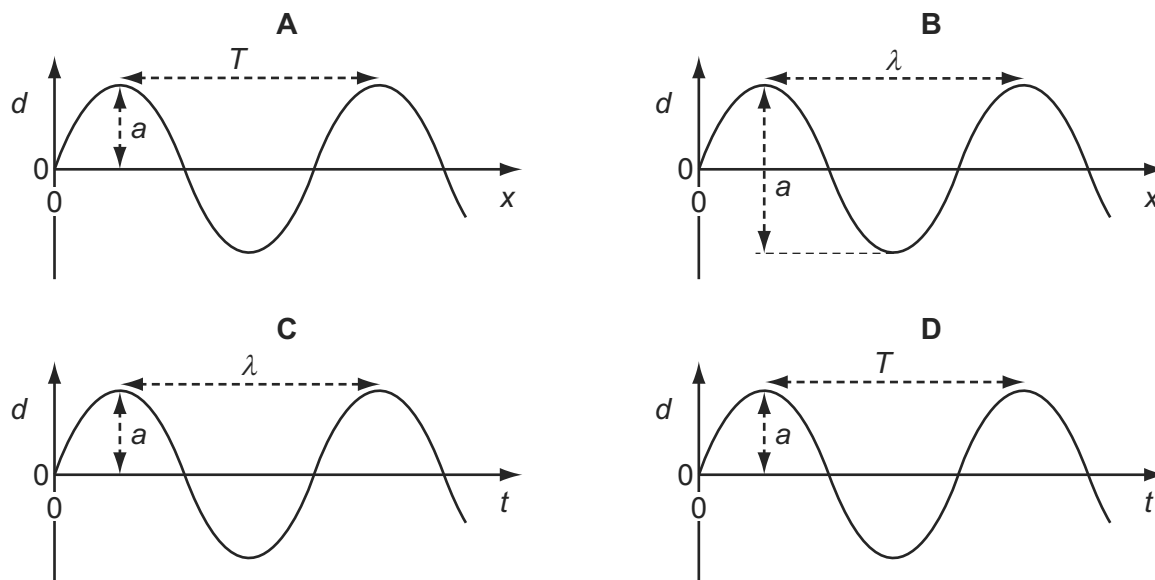

- 67 A source of sound of constant power  $P$  is situated in an open space. The intensity  $I$  of sound at distance  $r$  from this source is given by

9702/11/M/J/11/Q24

$$I = \frac{P}{4\pi r^2}.$$

How does the amplitude  $a$  of the vibrating air molecules vary with the distance  $r$  from the source?

- A**  $a \propto \frac{1}{r}$       **B**  $a \propto \frac{1}{r^2}$       **C**  $a \propto r$       **D**  $a \propto r^2$

- 68 P is a source emitting infra-red radiation and Q is a source emitting ultra-violet radiation. The figures in the table are suggested values for the wavelengths emitted by P and Q.

9702/11/O/N/11/Q27

Which row is correct?

	wavelength emitted by P/m	wavelength emitted by Q/m
<b>A</b>	$5 \times 10^{-5}$	$5 \times 10^{-8}$
<b>B</b>	$5 \times 10^{-5}$	$5 \times 10^{-10}$
<b>C</b>	$5 \times 10^{-7}$	$5 \times 10^{-8}$
<b>D</b>	$5 \times 10^{-7}$	$5 \times 10^{-10}$

69 A transverse progressive wave is set up on a string.

The graph shows the variation with time of displacement for a point on this string.

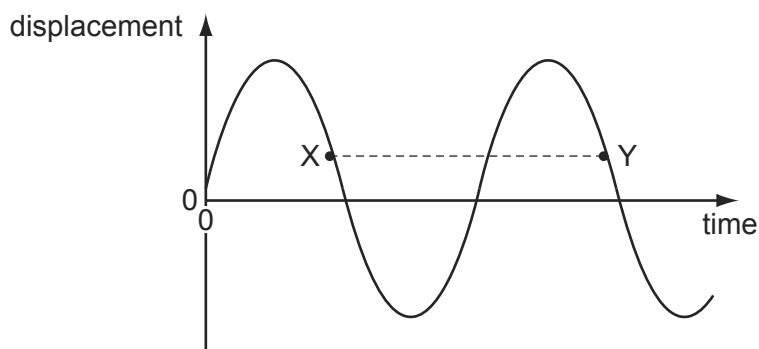

The separation XY on the graph represents the .....1..... of the wave.

X and Y have equal .....2..... .

Which words correctly complete gaps 1 and 2?

	1	2
<b>A</b>	time period	amplitudes
<b>B</b>	time period	displacements
<b>C</b>	wavelength	amplitudes
<b>D</b>	wavelength	displacements

70 If a wave can be polarised, it **must** be

9702/12/M/J/11/Q27

- A** a longitudinal wave.
- B** an electromagnetic wave.
- C** a sound wave.
- D** a transverse wave.

71 A source of sound of constant power  $P$  is situated in an open space. The intensity  $I$  of sound at distance  $r$  from this source is given by

9702/13/M/J/11/Q22

$$I = \frac{P}{4\pi r^2}.$$

How does the amplitude  $a$  of the vibrating air molecules vary with the distance  $r$  from the source?

- A**  $a \propto \frac{1}{r}$
- B**  $a \propto \frac{1}{r^2}$
- C**  $a \propto r$
- D**  $a \propto r^2$

- 72 The four graphs represent a progressive wave on a stretched string. Graphs **A** and **B** show how the displacement  $d$  varies with distance  $x$  along the string at one instant. Graphs **C** and **D** show how the displacement  $d$  varies with time  $t$  at a particular value of  $x$ .

The labels on the graphs are intended to show the wavelength  $\lambda$ , the period  $T$  and the amplitude  $a$  of the wave, but only one graph is correctly labelled.

9702/13/M/J/11/Q23

Which graph is correctly labelled?

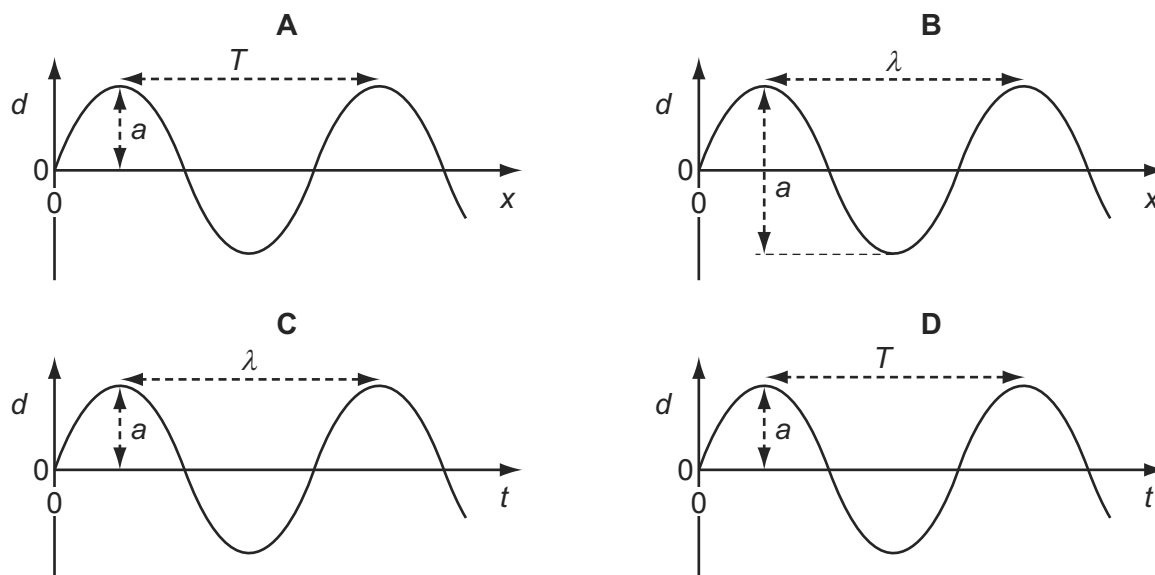

- 73 The diagram shows a view from above of a double slit interference demonstration. 9702/11/O/N/11/Q28

L is a monochromatic light source with a vertical filament. B is a barrier with two narrow vertical slits and S is a screen upon which interference fringes form.

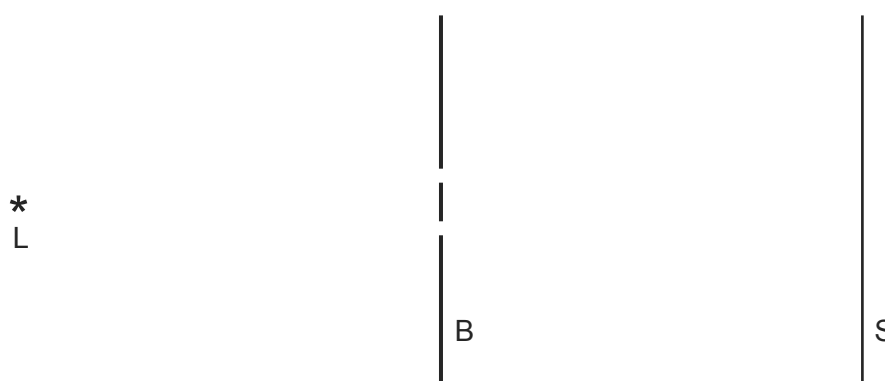

The intensity is  $I$  at a point on the screen where the centre of the fringe pattern forms.

What is the intensity, at the same point, when one of the slits is covered up?

- A**  $\frac{I}{\sqrt{2}}$       **B**  $\frac{I}{2}$       **C**  $\frac{I}{2\sqrt{2}}$       **D**  $\frac{I}{4}$

74 A wave that can be polarised must be

- A longitudinal.
- B progressive.
- C stationary.
- D transverse.

9702/12/O/N/11/Q25

75 Which statement about electromagnetic radiation is correct?

- A Waves of wavelength  $5 \times 10^{-9}$  m are high-energy gamma rays.
- B Waves of wavelength  $3 \times 10^{-8}$  m are ultra-violet waves.
- C Waves of wavelength  $5 \times 10^{-7}$  m are infra-red waves.
- D Waves of wavelength  $9 \times 10^{-7}$  m are light waves.

76 The diagram shows two sinusoidal waveforms.

9702/12/O/N/11/Q26

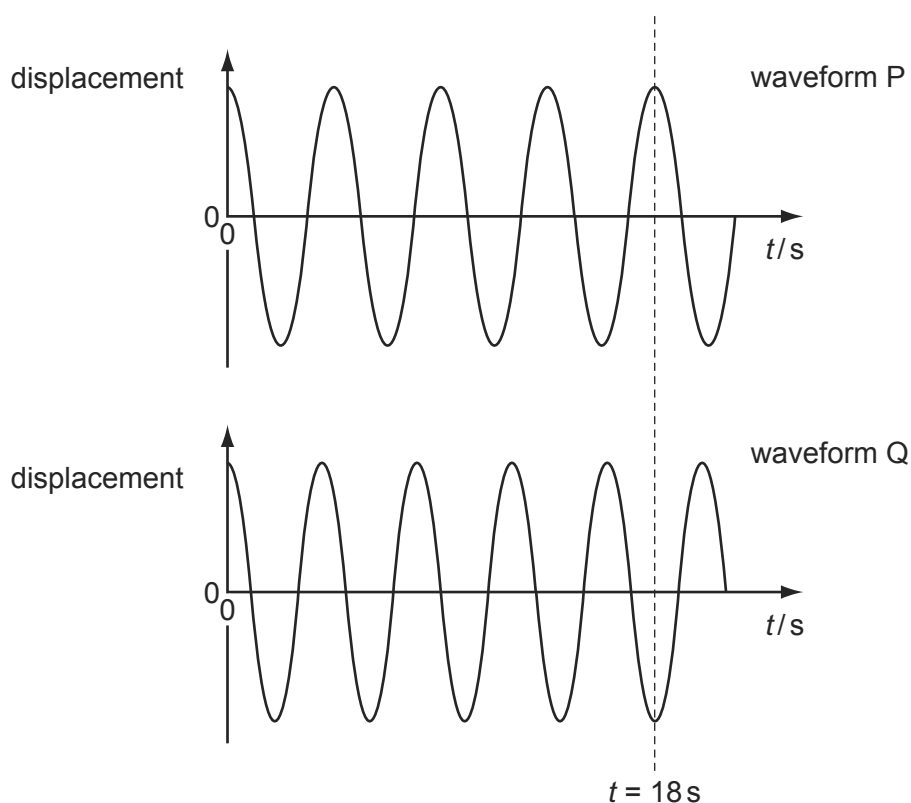

At time  $t = 0$  the waves are in phase. At the dotted line,  $t = 18$  s.

At which time is the phase difference between the two oscillations  $\frac{1}{8}$  of a cycle?

- A 4.0 s
- B 4.5 s
- C 8.0 s
- D 9.0 s

- 77 The diagram shows a view from above of a double slit interference demonstration. 9702/13/O/N/11/Q27

L is a monochromatic light source with a vertical filament. B is a barrier with two narrow vertical slits and S is a screen upon which interference fringes form.

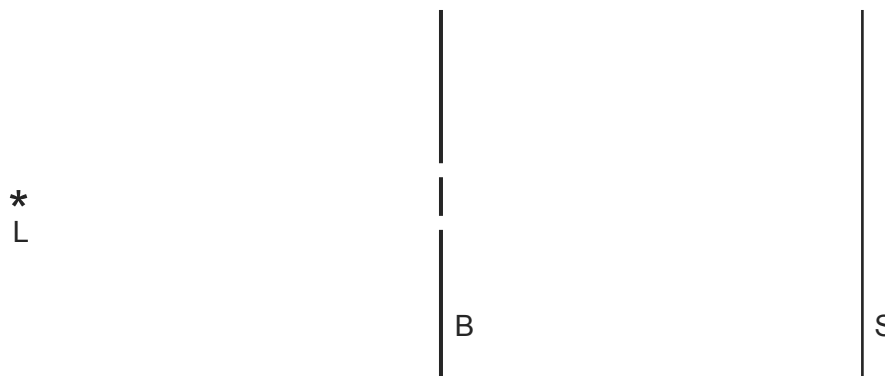

The intensity is  $I$  at a point on the screen where the centre of the fringe pattern forms.

What is the intensity, at the same point, when one of the slits is covered up?

- A**  $\frac{I}{\sqrt{2}}$       **B**  $\frac{I}{2}$       **C**  $\frac{I}{2\sqrt{2}}$       **D**  $\frac{I}{4}$

- 78 P is a source emitting infra-red radiation and Q is a source emitting ultra-violet radiation. The figures in the table are suggested values for the wavelengths emitted by P and Q. 9702/13/O/N/11/Q28

Which row is correct?

	wavelength emitted by P/m	wavelength emitted by Q/m
<b>A</b>	$5 \times 10^{-5}$	$5 \times 10^{-8}$
<b>B</b>	$5 \times 10^{-5}$	$5 \times 10^{-10}$
<b>C</b>	$5 \times 10^{-7}$	$5 \times 10^{-8}$
<b>D</b>	$5 \times 10^{-7}$	$5 \times 10^{-10}$

- 79 Which observation indicates that sound waves are longitudinal? 9702/11/M/J/12/Q28

- A** Sound can be reflected from a solid surface.  
**B** Sound cannot be polarised.  
**C** Sound is diffracted around corners.  
**D** Sound is refracted as it passes from hot air to cold air.

80 Two waves E and G are shown. The waves have the same speed.

9702/11/M/J/12/Q26

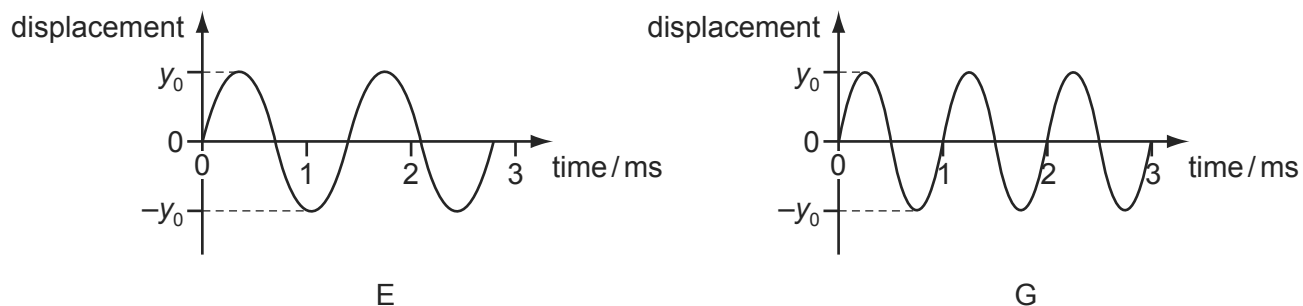

Which statement is correct?

- A Wave E has a greater amplitude than wave G.
- B Wave E has a greater intensity than wave G.
- C Wave E has a smaller frequency than wave G.
- D Wave E has a smaller wavelength than wave G.

81 The diagram shows a displacement-time graph for a progressive wave.

9702/11/M/J/12/Q27

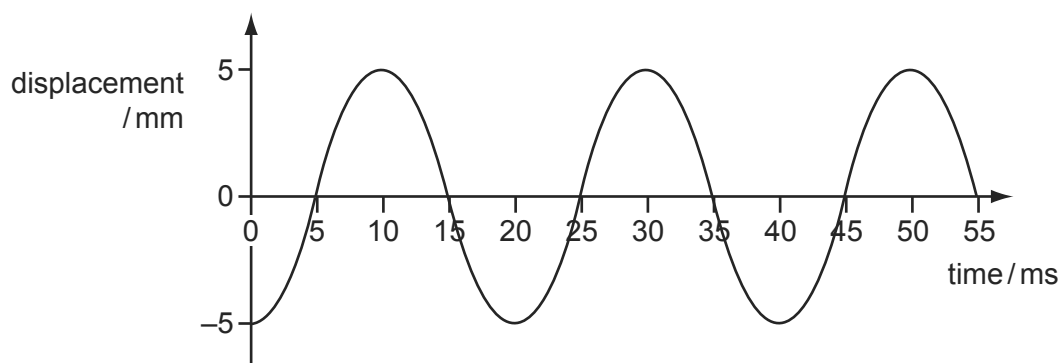

What are the amplitude and frequency of the wave?

	amplitude / mm	frequency / Hz
<b>A</b>	5	40
<b>B</b>	5	50
<b>C</b>	10	40
<b>D</b>	10	50

82 A surveyor's device emits a laser pulse.

9702/12/M/J/12/Q26

What is the time taken for the pulse to travel from the device to a wall 150 m away, where it is reflected, and then return to the device?

- A 0.05 ns
- B 0.10 ns
- C 0.50  $\mu$ s
- D 1.0  $\mu$ s

- 83 The period of an electromagnetic wave is 1.0 ns.

9702/12/M/J/12/Q27

What are the frequency and wavelength of the wave?

	frequency / Hz	wavelength / m
<b>A</b>	1.0	$3.0 \times 10^8$
<b>B</b>	$1.0 \times 10^6$	300
<b>C</b>	$1.0 \times 10^9$	0.30
<b>D</b>	$1.0 \times 10^{12}$	$3.0 \times 10^{-4}$

- 84 X and Y are two points on the surface of water in a ripple tank. A source of waves of constant frequency begins to generate waves which then travel past X and Y, causing them to oscillate.

9702/12/M/J/12/Q28

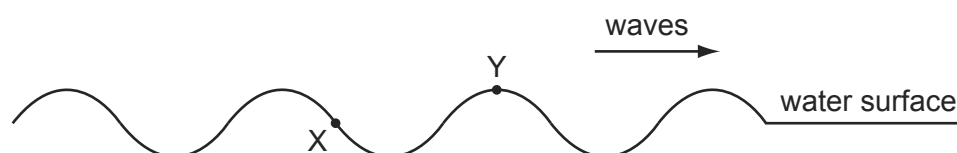

What is the phase difference between X and Y?

- A**  $45^\circ$       **B**  $135^\circ$       **C**  $180^\circ$       **D**  $270^\circ$
- 85 The diagram shows a displacement-time graph for a progressive wave.

9702/13/M/J/12/Q26

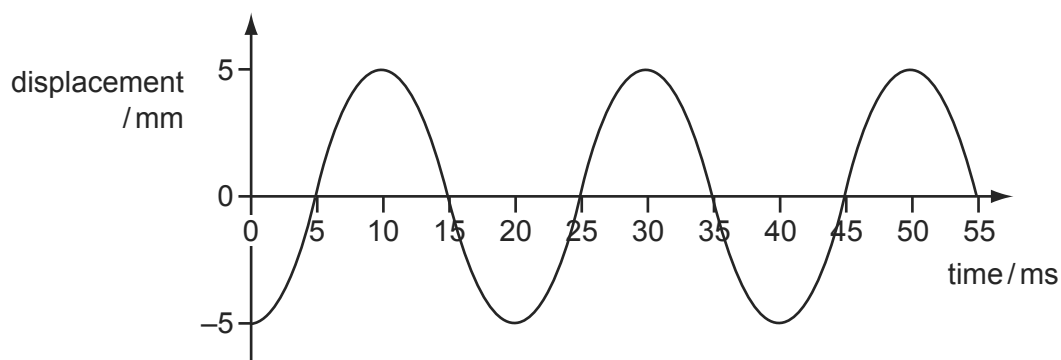

What are the amplitude and frequency of the wave?

	amplitude / mm	frequency / Hz
<b>A</b>	5	40
<b>B</b>	5	50
<b>C</b>	10	40
<b>D</b>	10	50



86 Two waves E and G are shown. The waves have the same speed.

9702/13/M/J/12/Q27

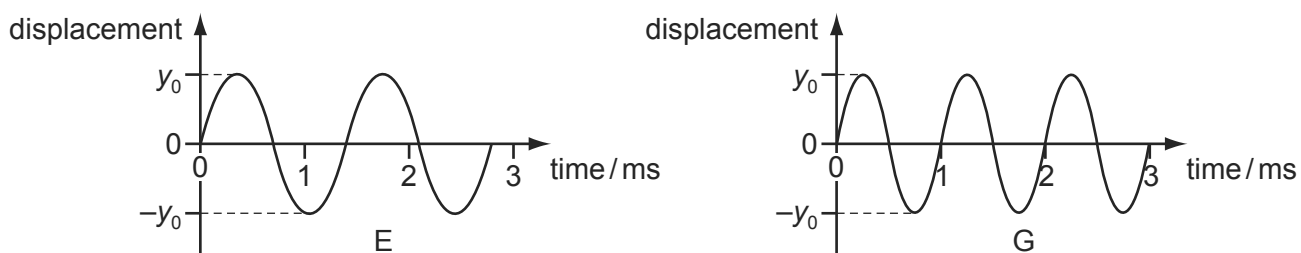

Which statement is correct?

- A Wave E has a greater amplitude than wave G.
  - B Wave E has a greater intensity than wave G.
  - C Wave E has a smaller frequency than wave G.
  - D Wave E has a smaller wavelength than wave G.
- 87 Which observation indicates that sound waves are longitudinal?

9702/13/M/J/12/Q29

- A Sound can be reflected from a solid surface.
- B Sound cannot be polarised.
- C Sound is diffracted around corners.
- D Sound is refracted as it passes from hot air to cold air.

88 The diagram shows a cathode-ray oscilloscope display of an electromagnetic wave. 9702/12/O/N/12/Q31

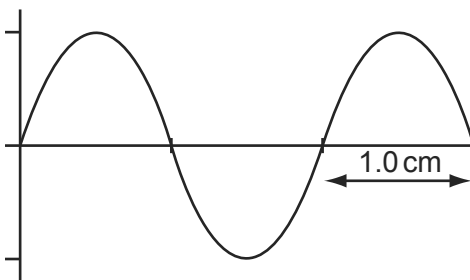

The time base setting is  $0.20 \mu\text{s cm}^{-1}$ .

Which statement is correct?

- A The frequency of the wave is 2.5 MHz and it lies in the radio wave region of the electromagnetic spectrum.
- B The frequency of the wave is 2.5 MHz and it lies in the microwave region of the electromagnetic spectrum.
- C The frequency of the wave is 5.0 MHz and it lies in the radio wave region of the electromagnetic spectrum.
- D The frequency of the wave is 5.0 MHz and it lies in the microwave region of the electromagnetic spectrum.

89 The diagram shows a graph of displacement against time for a sound wave.

9702/11/O/N/12/Q26

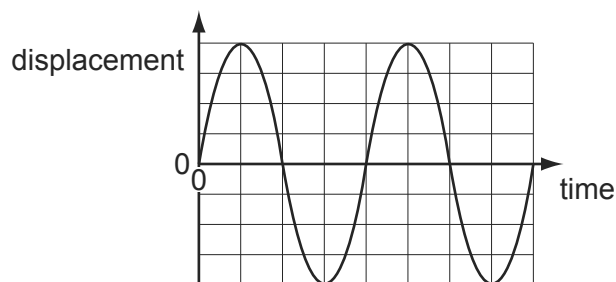

The intensity of the sound is halved.

Which graph shows the displacement of this sound wave?

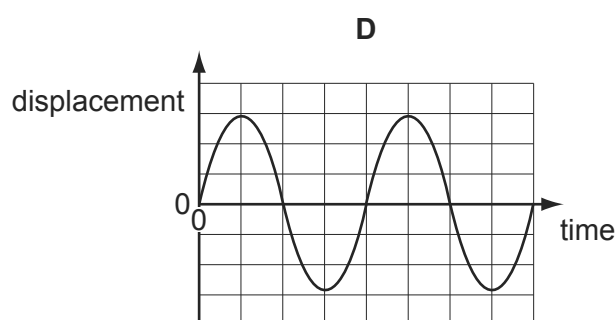
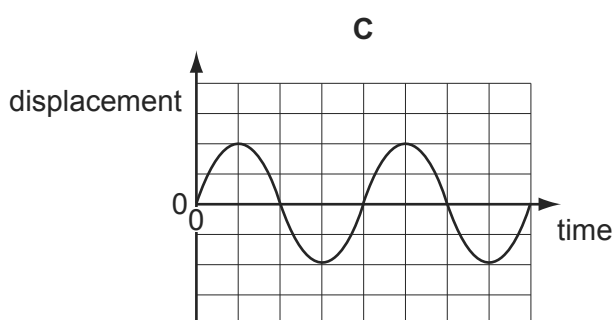
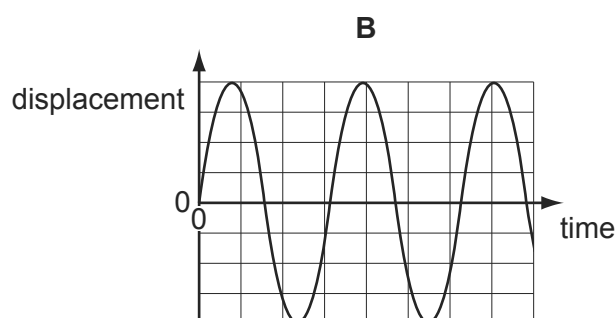
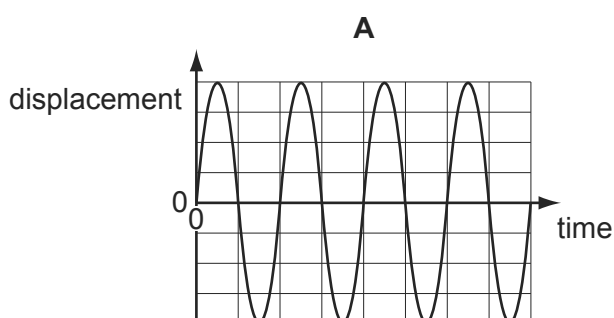

90 What do **not** travel at the speed of light in a vacuum?

9702/11/O/N/12/Q27

- A** electrons
- B** microwaves
- C** radio waves
- D** X-rays

91 A health inspector is measuring the intensity of a sound. Near a loudspeaker, his meter records an intensity  $I$ . This corresponds to an amplitude  $A$  of the sound wave. At another position, the meter gives an intensity reading of  $2I$ .

9702/13/O/N/12/Q29

What is the corresponding amplitude of the sound wave?

- A**  $\frac{A}{\sqrt{2}}$
- B**  $\sqrt{2}A$
- C**  $2A$
- D**  $4A$

- 92 Diffraction can be observed when a wave passes an obstruction. The diffraction effect is greatest when the wavelength and the obstruction are similar in size. 9702/13/O/N/12/Q28

For waves travelling through air, what is the combination of wave and obstruction that could best demonstrate diffraction?

- A** microwaves passing a steel post  
**B** radio waves passing a copper wire  
**C** sound waves passing a human hair  
**D** visible light waves passing a gate post
- 93 A wave has a speed of  $340 \text{ m s}^{-1}$  and a period of  $0.28 \text{ ms}$ . 9702/11/M/J/13/Q25

What is its wavelength?

- A**  $0.095 \text{ m}$       **B**  $95 \text{ m}$       **C**  $1.2 \times 10^3 \text{ m}$       **D**  $1.2 \times 10^6 \text{ m}$
- 94 Which line in the table summarises the change in wave characteristics on going from infra-red to ultraviolet in the electromagnetic spectrum? 9702/11/M/J/13/Q26

	frequency	speed in a vacuum
<b>A</b>	decreases	decreases
<b>B</b>	decreases	remains constant
<b>C</b>	increases	remains constant
<b>D</b>	increases	increases

- 95 A light wave of amplitude  $A$  is incident normally on a surface of area  $S$ . The power per unit area reaching the surface is  $P$ . 9702/11/M/J/13/Q24

The amplitude of the light wave is increased to  $2A$ . The light is then focussed on to a smaller area  $\frac{1}{3}S$ .

What is the power per unit area on this smaller area?

- A**  $36P$   
**B**  $18P$   
**C**  $12P$   
**D**  $6P$

- 96 The order of magnitude of the frequency of the shortest wavelength of visible light waves can be expressed as  $10^x$  Hz. 9702/12/M/J/13/Q24

What is the value of  $x$ ?

- A** 12                      **B** 13                      **C** 14                      **D** 15

- 97 The diagram shows two waves X and Y. 9702/12/M/J/13/Q25

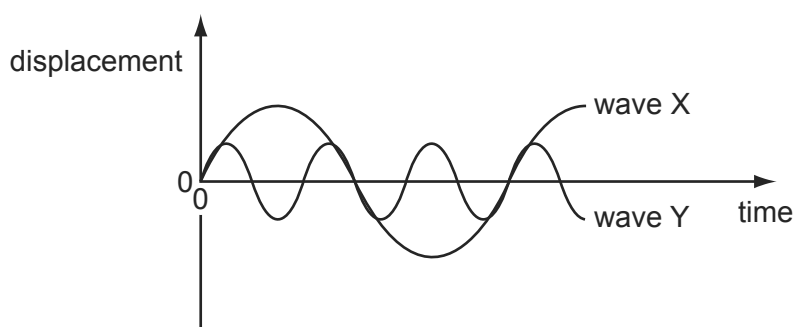

Wave X has amplitude 8 cm and frequency 100 Hz.

What are the amplitude and the frequency of wave Y?

	amplitude/cm	frequency/Hz
<b>A</b>	2	33
<b>B</b>	2	300
<b>C</b>	4	33
<b>D</b>	4	300

- 98 What is correct for all transverse waves? 9702/12/M/J/13/Q26

- A** They are all electromagnetic.  
**B** They can all be polarised.  
**C** They can all travel through a vacuum.  
**D** They all involve the oscillation of atoms.

- 99 Which statement about different types of electromagnetic wave is correct? 9702/13/M/J/13/Q22

- A** The frequency of infra-red waves is less than the frequency of blue light.  
**B** The frequency of radio waves is greater than the frequency of gamma rays.  
**C** The wavelength of red light is less than the wavelength of ultraviolet waves.  
**D** The wavelength of X-rays is greater than the wavelength of microwaves.

100 Electromagnetic waves of wavelength  $\lambda$  and frequency  $f$  travel at speed  $c$  in a vacuum.

What describes the wavelength and speed of electromagnetic waves of frequency  $f/2$ ?

9702/13/M/J/13/Q24

	wavelength	speed in a vacuum
<b>A</b>	$\lambda/2$	$c/2$
<b>B</b>	$\lambda/2$	$c$
<b>C</b>	$2\lambda$	$c$
<b>D</b>	$2\lambda$	$2c$

101 Orange light has a wavelength of 600 nm.

9702/13/M/J/13/Q23

What is the frequency of this light?

- A** 180 GHz      **B** 180 Hz      **C** 500 THz      **D** 500 kHz

102 A sound wave has displacement  $y$  at distance  $x$  from its source at time  $t$ .

9702/13/M/J/13/Q26

Which graph correctly shows the amplitude  $a$  and the wavelength  $\lambda$  of the wave?

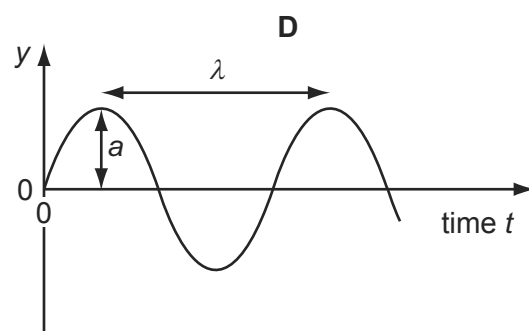
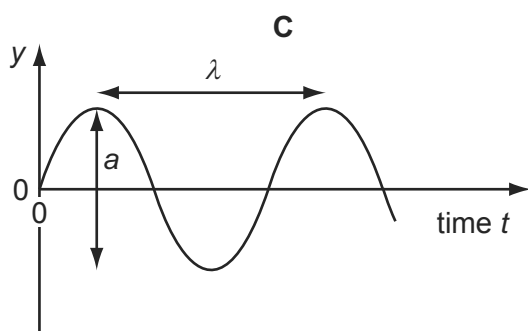
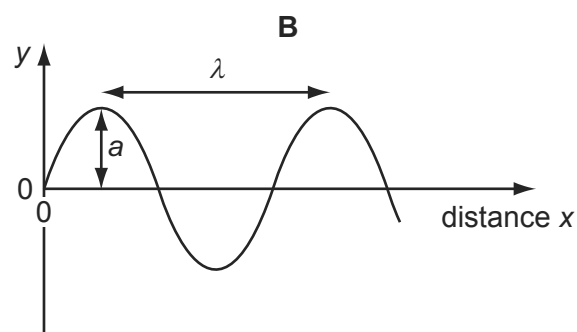
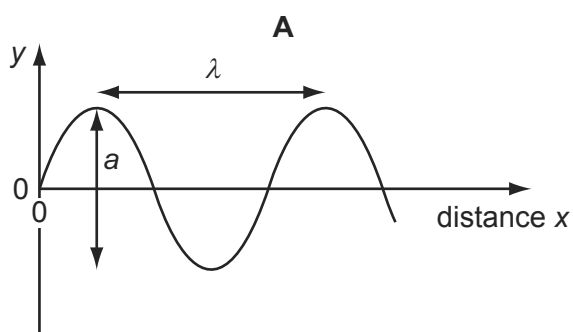

- 103 When the liquid crystal display of a calculator is observed through a polarising film, the display changes as the film is rotated. 9702/13/M/J/13/Q25

Which property describes the radiation from the calculator display?

- A unpolarised
  - B a longitudinal wave
  - C a transverse wave
  - D a wave with a 3 cm wavelength
- 104 A wave has a frequency of 5 GHz. 9702/11/M/J/13/Q4

What is the period of the wave?

- A 20 000  $\mu\text{s}$
  - B 20 ns
  - C 2 ns
  - D 200 ps
- 105 The diagram shows a sketch of a wave pattern, over a short period of time. 9702/11/O/N/13/Q25

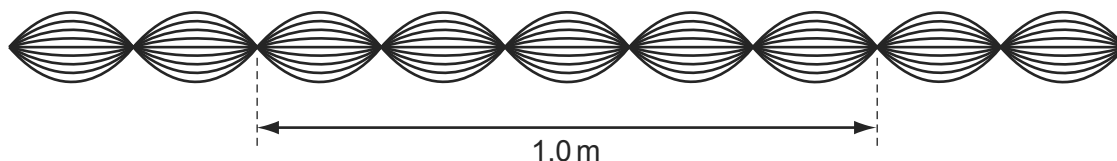

Which description of this wave is correct?

- A The wave is longitudinal, has a wavelength of 20 cm and is stationary.
  - B The wave is transverse, has a wavelength of 20 cm and is stationary.
  - C The wave is transverse, has a wavelength of 40 cm and is progressive.
  - D The wave is transverse, has a wavelength of 40 cm and is stationary.
- 106 Which statement about a light wave and a sound wave is correct? 9702/11/O/N/13/Q26
- A Both can be polarised.
  - B Both can travel through free space.
  - C Both have a frequency inversely proportional to their wavelength.
  - D Both have an intensity proportional to their amplitude.

- 107 When plane-polarised light of amplitude  $A$  is passed through a polarising filter as shown, the amplitude of the light emerging is  $A \cos \theta$ .

9702/11/O/N/13/Q30

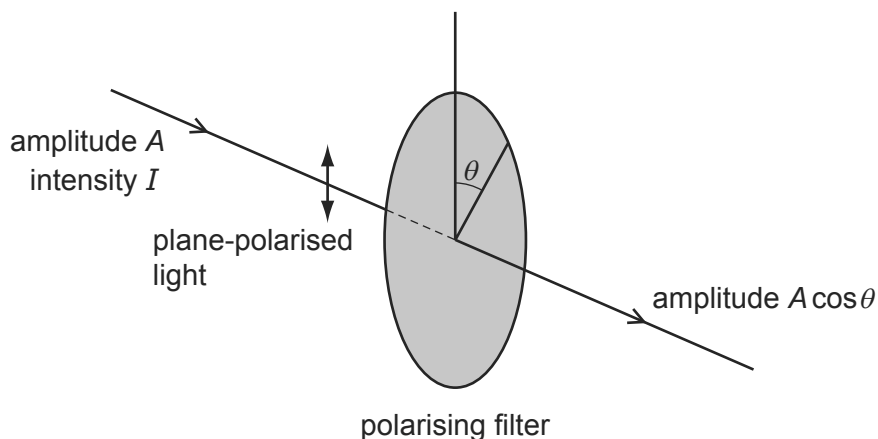

The intensity of the initial beam is  $I$ .

What is the intensity of the emerging light when  $\theta$  is  $60.0^\circ$ ?

- A**  $0.250I$       **B**  $0.500I$       **C**  $0.750I$       **D**  $0.866I$

- 108 The graph shows how the height of the water surface at a point in a harbour varies with time  $t$  as waves pass the point.

9702/13/O/N/13/Q25

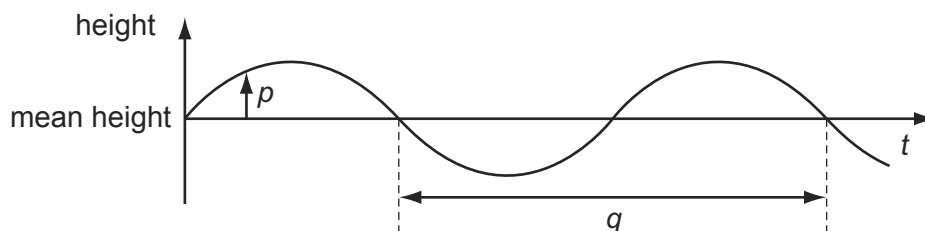

What are  $p$  and  $q$ ?

	$p$	$q$
<b>A</b>	displacement	period
<b>B</b>	displacement	wavelength
<b>C</b>	amplitude	period
<b>D</b>	amplitude	wavelength

- 109 Electromagnetic waves from an unknown source in space were found to be significantly diffracted when passing through gaps of the order of  $10^{-5}$  m.

9702/13/O/N/13/Q24

Which type of wave are they most likely to be?

- A** radio waves  
**B** microwaves  
**C** infra-red waves  
**D** ultraviolet waves
- 110 A cathode-ray oscilloscope (c.r.o.) displays a waveform corresponding to a sound wave.

In order to determine the frequency of the sound wave, which part of the displayed waveform must be measured and which c.r.o. setting must be known?

9702/13/M/J/14/Q25

	on-screen measurement	c.r.o. setting
<b>A</b>	amplitude	time-base
<b>B</b>	amplitude	Y-gain
<b>C</b>	wavelength	time-base
<b>D</b>	wavelength	Y-gain

- 111 Which statement about longitudinal waves is correct?

9702/11/M/J/14/Q22

- A** Longitudinal waves include radio waves travelling through air.  
**B** Particles in a longitudinal wave vibrate at right-angles to the direction of transfer of wave energy.  
**C** Some types of longitudinal wave can be polarised.  
**D** Stationary waves can be produced by the superposition of longitudinal waves.
- 112 The order of magnitude of the frequency of the longest-wavelength ultraviolet waves can be expressed as  $10^x$  Hz.

9702/11/M/J/14/Q23

What is the value of  $x$ ?

- A** 13                      **B** 15                      **C** 17                      **D** 19



113 What is the approximate range of frequencies of infra-red radiation?

9702/13/M/J/14/Q26

- A**  $1 \times 10^3$  Hz to  $1 \times 10^9$  Hz  
**B**  $1 \times 10^9$  Hz to  $1 \times 10^{11}$  Hz  
**C**  $1 \times 10^{11}$  Hz to  $1 \times 10^{14}$  Hz  
**D**  $1 \times 10^{14}$  Hz to  $1 \times 10^{17}$  Hz

114 A small source emits spherical waves.

9702/13/M/J/14/Q27

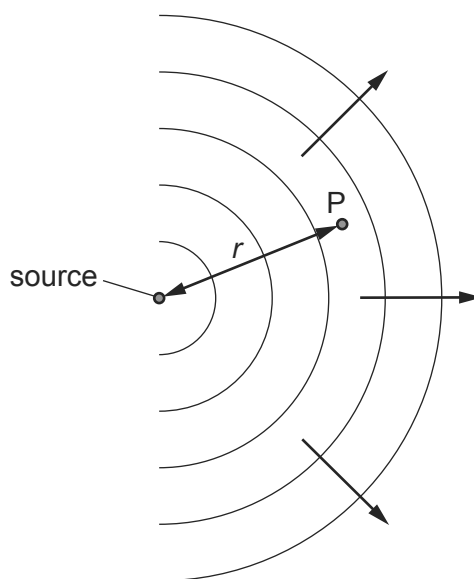

The wave intensity  $I$  at any point P, a distance  $r$  from the source, is inversely proportional to  $r^2$ .

What is the relationship between the wave amplitude  $a$  and the distance  $r$ ?

- A**  $a^2 \propto \frac{1}{r}$       **B**  $a \propto \frac{1}{r}$       **C**  $a \propto \frac{1}{r^2}$       **D**  $a \propto \frac{1}{r^4}$

115 The speed  $v$  of waves in deep water is given by the equation  $v^2 = \frac{g\lambda}{2\pi}$

9702/11/M/J/14/Q24

where  $\lambda$  is the wavelength of the waves and  $g$  is the acceleration of free fall.

A student measures the wavelength  $\lambda$  and the frequency  $f$  of a number of these waves.

Which graph should he plot to give a straight line through the origin?

- A**  $f^2$  against  $\lambda$   
**B**  $f$  against  $\lambda^2$   
**C**  $f$  against  $\frac{1}{\lambda}$   
**D**  $f^2$  against  $\frac{1}{\lambda}$

- 116 A sound wave consists of a series of moving pressure variations from the normal, constant air pressure.

9702/12/M/J/14/Q23

The graph shows these pressure variations for two waves at one instant in time.

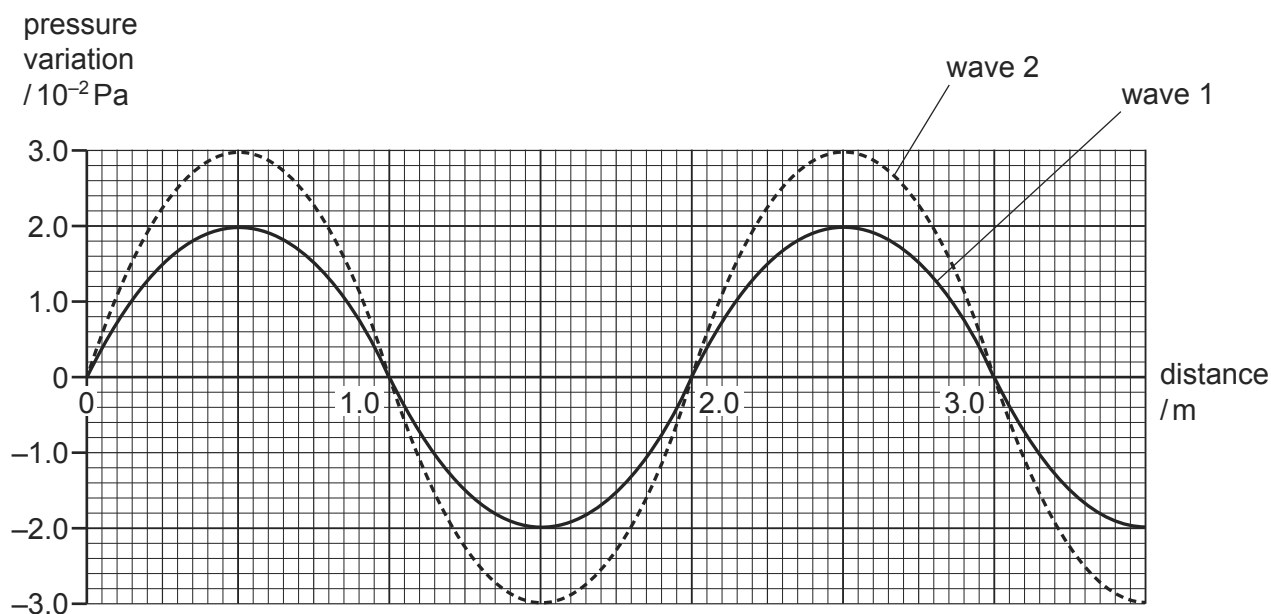

Wave 1 has an intensity of  $1.6 \times 10^{-6} \text{ W m}^{-2}$ .

What is the intensity of wave 2?

- A**  $2.4 \times 10^{-6} \text{ W m}^{-2}$
- B**  $3.0 \times 10^{-6} \text{ W m}^{-2}$
- C**  $3.6 \times 10^{-6} \text{ W m}^{-2}$
- D**  $4.5 \times 10^{-6} \text{ W m}^{-2}$
- 117 The diagram shows a vertical cross-section through a water wave moving from left to right.

9702/12/M/J/14/Q24

At which point is the water moving upwards with maximum speed?

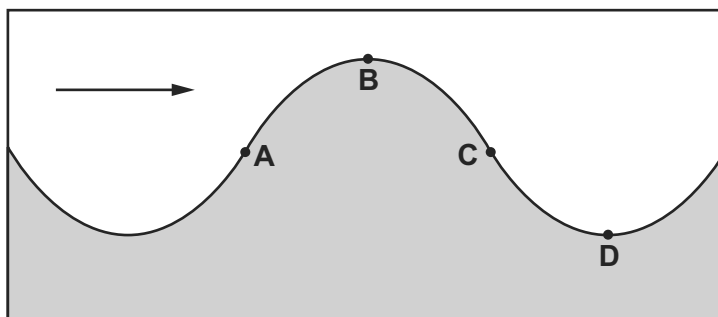

- 118 What, to two significant figures, are the period, the frequency and the amplitude of the wave represented by the graph?

9702/12/M/J/14/Q22

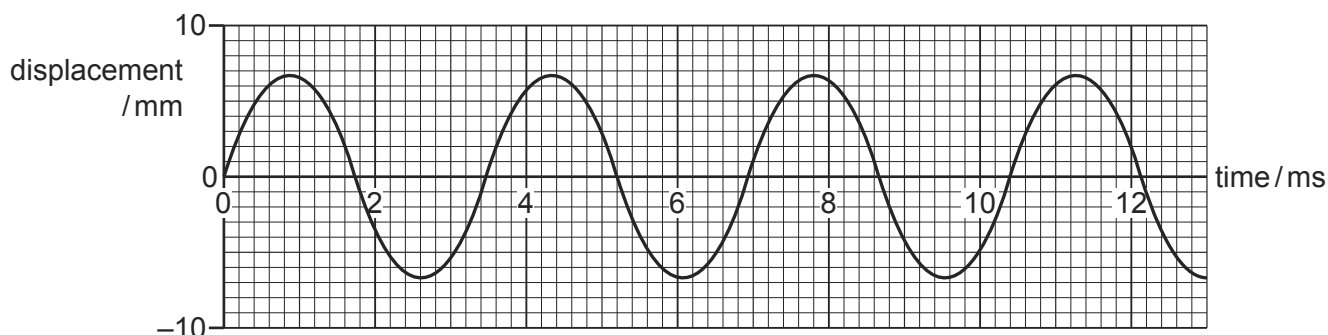

	period /s	frequency /Hz	amplitude /m
<b>A</b>	0.0027	370	0.0067
<b>B</b>	0.0031	320	0.013
<b>C</b>	0.0035	290	0.0067
<b>D</b>	0.0042	240	0.013

- 119 Which statement about waves is correct?

9702/13/O/N/14/Q26

- A** All electromagnetic waves travel at the same speed in a vacuum.
- B** Longitudinal waves can be polarised.
- C** The amplitude of a wave is directly proportional to the energy transferred by the wave.
- D** The frequency of infra-red light is greater than the frequency of ultra-violet light.

- 120 Which statement describes a situation when polarisation could **not** occur?

9702/11/O/N/14/Q24

- A** Light waves are reflected.
- B** Light waves are scattered.
- C** Microwaves pass through a metal grid.
- D** Sound waves pass through a metal grid.

- 121 A stationary sound wave is produced in a tube.

9702/11/O/N/14/Q25

Which statement describes the wave speed?

- A** It is the distance between two adjacent nodes divided by the period of the wave.
- B** It is the speed at which energy is transferred from one antinode to an adjacent antinode.
- C** It is the speed of a particle at an antinode.
- D** It is the speed of one of the progressive waves that are producing the stationary wave.

- 122 The variation with distance  $x$  of the intensity  $I$  along a stationary sound wave in air is shown by the following graph. 9702/13/O/N/14/Q27

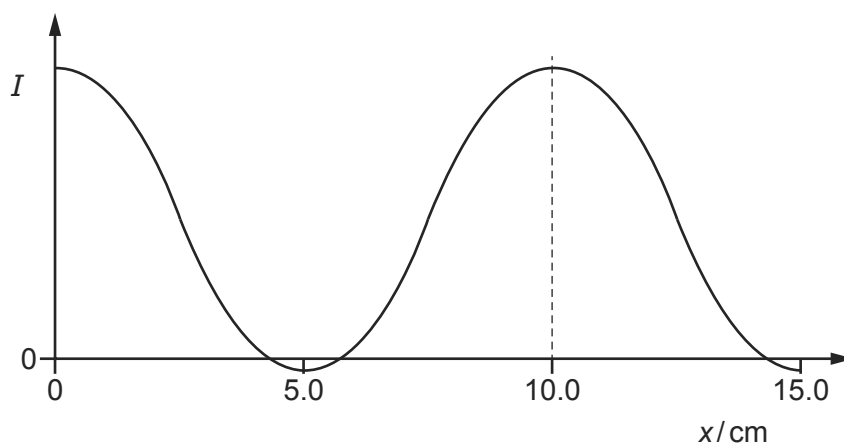

The speed of sound in air is  $340 \text{ m s}^{-1}$ .

What is the frequency of the sound wave?

- A** 1700 Hz      **B** 2270 Hz      **C** 3400 Hz      **D** 6800 Hz
- 123 Plane wavefronts in a ripple tank pass through a gap as shown. 9702/13/O/N/14/Q28

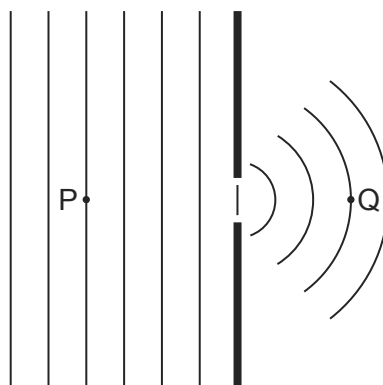

Which property of the wave will be different at Q compared with P?

- A** velocity  
**B** frequency  
**C** amplitude  
**D** wavelength
- 124 Which statement about electromagnetic radiation is correct? 9702/11/O/N/14/Q22
- A** Waves of wavelength  $5 \times 10^{-9} \text{ m}$  are high-energy gamma rays.  
**B** Waves of wavelength  $3 \times 10^{-8} \text{ m}$  are ultra-violet waves.  
**C** Waves of wavelength  $5 \times 10^{-7} \text{ m}$  are infra-red waves.  
**D** Waves of wavelength  $9 \times 10^{-7} \text{ m}$  are light waves.

- 125 When sound travels through air, the air particles vibrate. A graph of displacement against time for a single air particle is shown.

9702/11/O/N/14/Q23

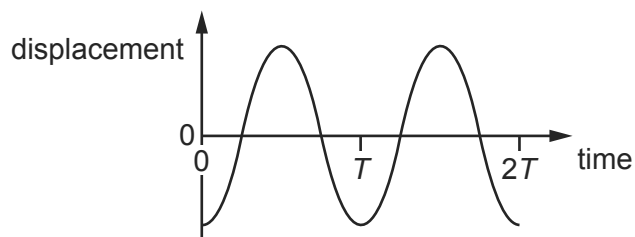

Which graph best shows how the kinetic energy of the air particle varies with time?

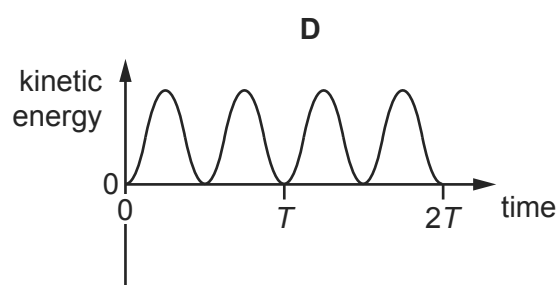
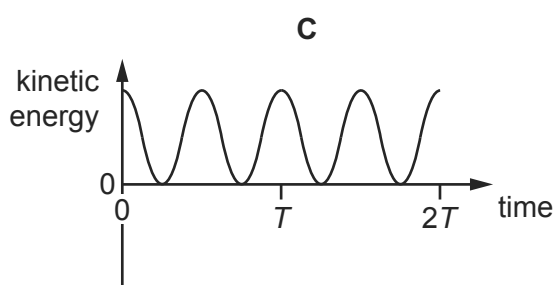
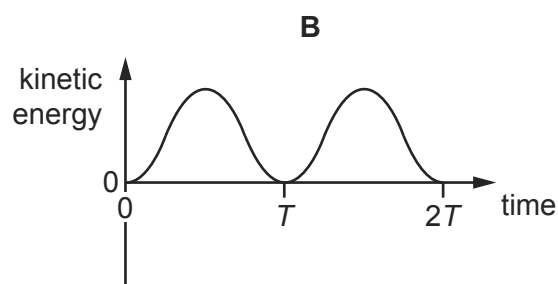
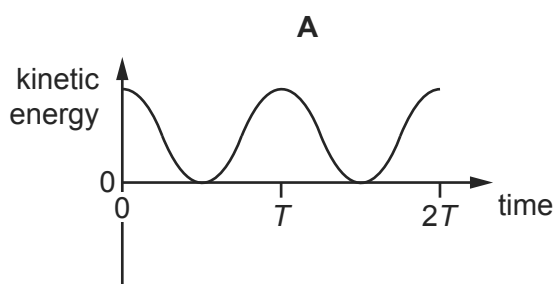

- 126 Two light waves of the same frequency are represented by the diagram.

9702/12/M/J/15/Q24

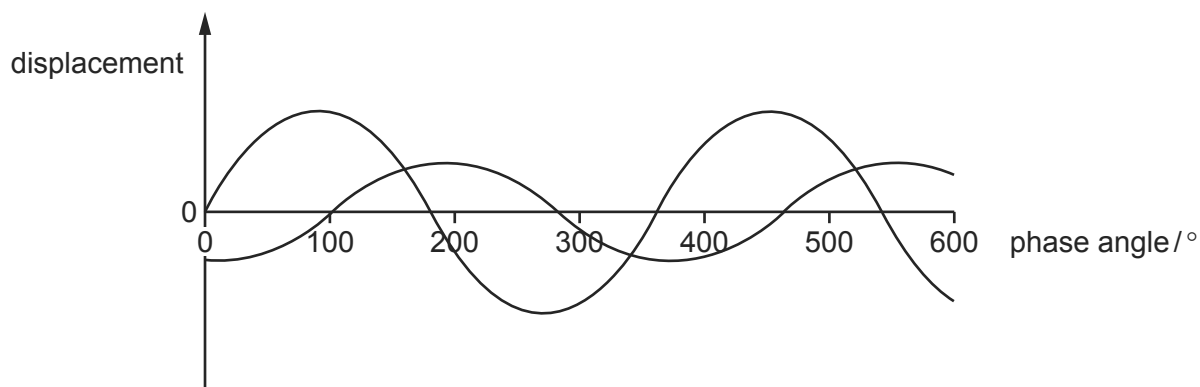

What could be the phase difference between the two waves?

- A**  $150^\circ$       **B**  $220^\circ$       **C**  $260^\circ$       **D**  $330^\circ$

- 127 A cathode-ray oscilloscope (c.r.o.) is used to display the trace from a sound wave. The time-base is set at  $5 \mu\text{s mm}^{-1}$ .

9702/13/M/J/15/Q25

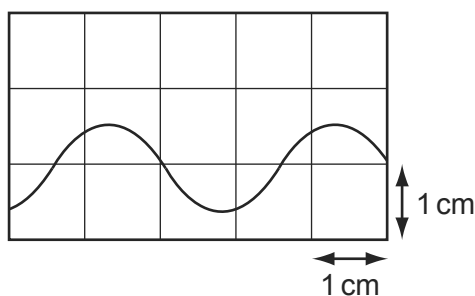

What is the frequency of the sound wave?

- A** 6.7 Hz      **B** 67 Hz      **C** 6.7 kHz      **D** 67 kHz
- 128 A wave pulse moves along a stretched rope in the direction shown.

9702/13/M/J/15/Q26

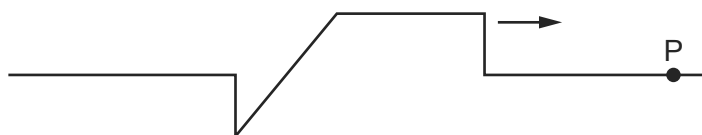

Which diagram correctly shows the variation with time  $t$  of the displacement  $s$  of the particle P in the rope?

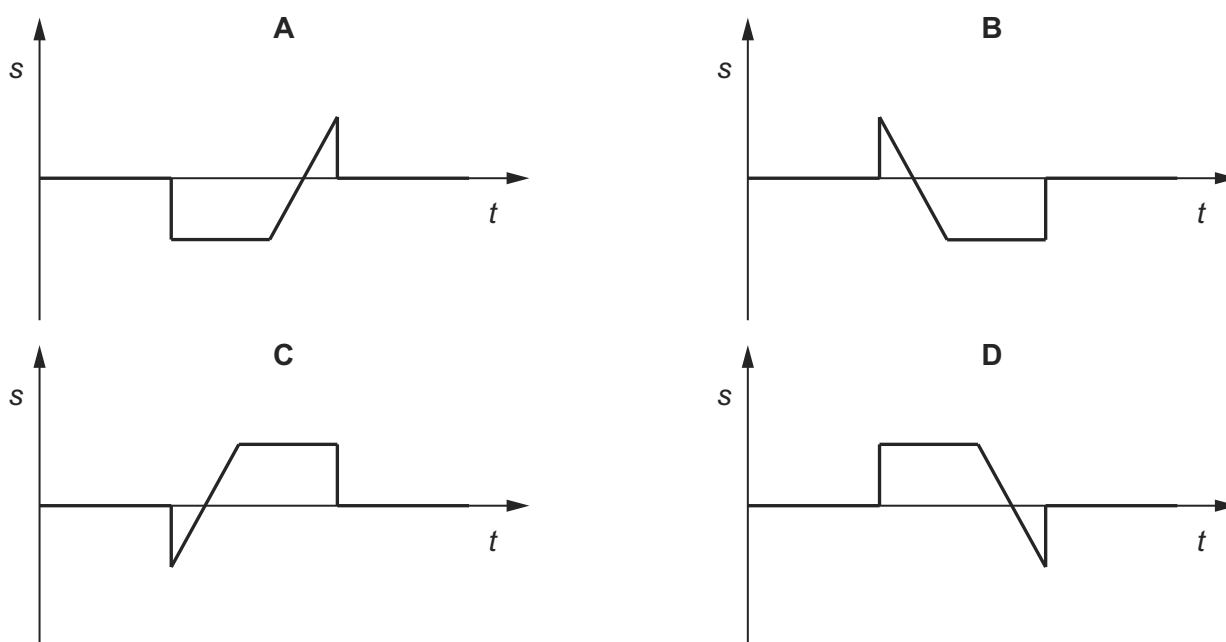

- 129 A sound wave has a speed of  $330 \text{ m s}^{-1}$  and a frequency of 50 Hz.

9702/12/M/J/15/Q25

What is a possible distance between two points on the wave that have a phase difference of  $60^\circ$ ?

- A** 0.03 m      **B** 1.1 m      **C** 2.2 m      **D** 6.6 m

- 130 Which electromagnetic wave would cause the most significant diffraction effect for an atomic lattice of spacing around  $10^{-10}$  m?

9702/13/M/J/15/Q28

- A infra-red
- B microwave
- C ultraviolet
- D X-ray

- 131 A sound wave moves with a speed of  $320 \text{ ms}^{-1}$  through air. The variation with time of the displacement of an air particle due to this wave is shown in the graph.

9702/11/M/J/15/Q24

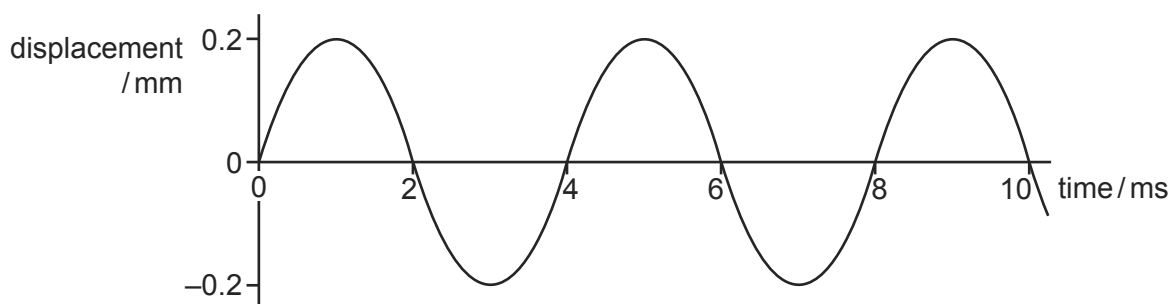

Which statement about the sound wave is correct?

- A The frequency of the wave is 500 Hz.
  - B The graph shows that sound is a transverse wave.
  - C The intensity of the wave will be doubled if its amplitude is increased to 0.4 mm.
  - D The wavelength of the sound wave is 1.28 m.
- 132 A wave of frequency  $15 \text{ Hz}$  travels at  $24 \text{ m s}^{-1}$  through a medium.

9702/11/M/J/15/Q25

What is the phase difference between two points 2 m apart?

- A There is no phase difference.
- B They are out of phase by a quarter of a cycle.
- C They are out of phase by half a cycle.
- D They are out of phase by 0.8 of a cycle.

- 133 A wave of amplitude  $a$  has an intensity of  $3.0 \text{ W m}^{-2}$ .

9702/11/M/J/15/Q26

What is the intensity of a wave of the same frequency that has an amplitude  $2a$ ?

- A  $4.2 \text{ W m}^{-2}$
- B  $6.0 \text{ W m}^{-2}$
- C  $9.0 \text{ W m}^{-2}$
- D  $12 \text{ W m}^{-2}$

- 134 An electromagnetic wave has a wavelength that is numerically of the same order of magnitude as the diameter of a nucleus.

9702/11/M/J/15/Q27

In which region of the electromagnetic spectrum does the wave occur?

- A** gamma ray
- B** X-ray
- C** visible light
- D** infra-red



- 1 The diagram shows an experiment which has been set up to demonstrate two-source interference, using microwaves of wavelength  $\lambda$ .

9702/1/M/J/02/Q28

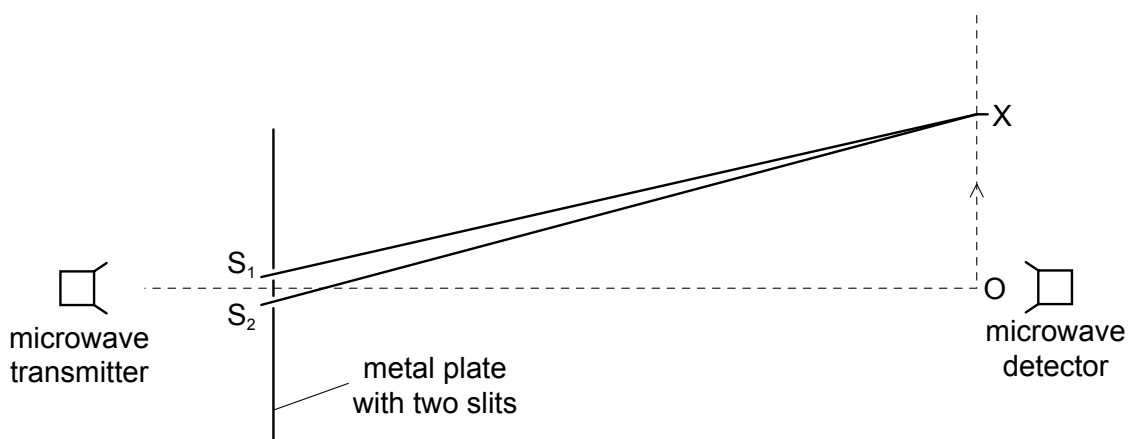

The detector is moved from O in the direction of the arrow. The signal detected decreases until the detector reaches the point X, and then starts to increase again as the detector moves beyond X.

Which equation correctly determines the position of X?

- A  $OX = \lambda/2$       B  $OX = \lambda$       C  $S_2X - S_1X = \lambda/2$       D  $S_2X - S_1X = \lambda$
- 2 Two progressive waves of frequency 300 Hz are superimposed to produce a stationary wave in which adjacent nodes are 1.5 m apart.

9702/1/M/J/02/Q29

What is the speed of the progressive waves?

- A  $100 \text{ m s}^{-1}$       B  $200 \text{ m s}^{-1}$       C  $450 \text{ m s}^{-1}$       D  $900 \text{ m s}^{-1}$
- 3 Coherent monochromatic light illuminates two narrow parallel slits and the interference pattern that results is observed on a screen some distance beyond the slits.

9702/1/O/N/02/Q28

Which change increases the separation between the dark lines of the interference pattern?

- A using monochromatic light of higher frequency  
 B using monochromatic light of a longer wavelength  
 C decreasing the distance between the screen and the slits  
 D increasing the distance between the slits
- 4 Monochromatic light of wavelength 590 nm is incident normally on a diffraction grating. The angle between the two second-order diffracted beams is  $43^\circ$ .

9702/1/O/N/02/Q29

What is the spacing of the lines on the grating?

- A  $0.87 \mu\text{m}$       B  $1.6 \mu\text{m}$       C  $1.7 \mu\text{m}$       D  $3.2 \mu\text{m}$

- 5 The graph represents a stationary wave at two different times.

9702/01/M/J/03/Q24

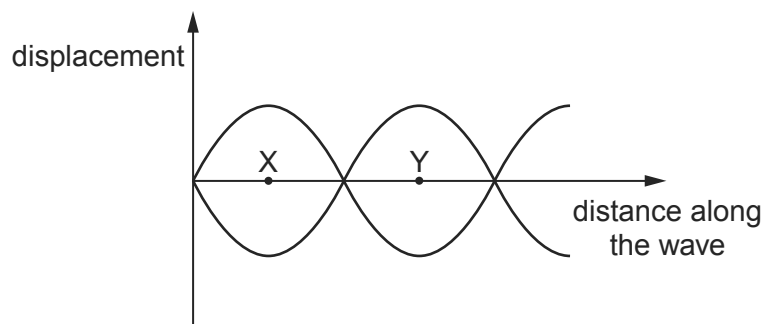

What does the distance XY represent?

- A half the amplitude  
 B half the frequency  
 C half the period  
 D half the wavelength
- 6 A diffraction grating is used to measure the wavelength of monochromatic light, as shown in the diagram.

9702/01/M/J/03/Q28

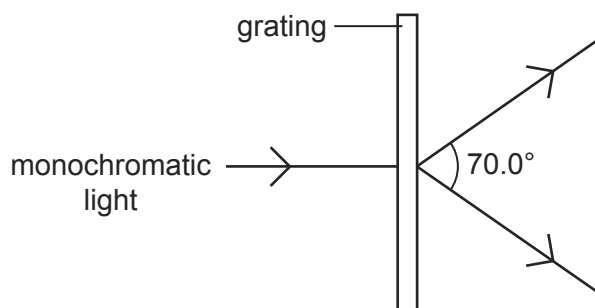

The spacing of the slits in the grating is  $1.00 \times 10^{-6} \text{ m}$ . The angle between the first order diffraction maxima is  $70.0^\circ$ .

What is the wavelength of the light?

- A 287 nm      B 470 nm      C 574 nm      D 940 nm
- 7 When the light from two lamps falls on a screen, no interference pattern can be obtained.

9702/01/M/J/03/Q27

Why is this?

- A The lamps are not point sources.  
 B The lamps emit light of different amplitudes.  
 C The light from the lamps is not coherent.  
 D The light from the lamps is white.

- 8 A stationary sound wave has a series of nodes. The distance between the first and the sixth node is 30.0 cm .

9702/01/O/N/03/Q24

What is the wavelength of the sound wave?

- A** 5.0 cm      **B** 6.0 cm      **C** 10.0 cm      **D** 12.0 cm

- 9 Which of the following may be used to produce stationary waves?

9702/01/O/N/03/Q26

- A** blowing air over the top of an empty bottle  
**B** making a loud sound near a mountain  
**C** passing monochromatic light through a double slit  
**D** passing water waves through a narrow slit

- 10 In an interference experiment, two slits are illuminated with white light.

9702/01/O/N/03/Q27



What is seen on the screen?

- A** The central fringe is black with black and white fringes on each side.  
**B** The central fringe is black with coloured fringes on each side.  
**C** The central fringe is white with black and white fringes on each side.  
**D** The central fringe is white with coloured fringes on each side.
- 11 Microwaves of wavelength 3.00 cm are incident normally on a row of parallel metal rods. The separation of the rods is 8.00 cm. The first order diffraction maximum is observed at an angle of  $22.0^\circ$  to the direction of the incident waves.

9702/01/O/N/03/Q28

What is the angle between the first and second order diffraction maxima?

- A**  $22.0^\circ$       **B**  $26.6^\circ$       **C**  $44.0^\circ$       **D**  $48.6^\circ$

- 12 The lines of a diffraction grating have a spacing of  $1.6 \times 10^{-6}$  m. A beam of light is incident normally on the grating. The first order maximum makes an angle of  $20^\circ$  with the undeviated beam.

9702/01/M/J/04/Q28

What is the wavelength of the incident light?

- A** 210 nm      **B** 270 nm      **C** 420 nm      **D** 550 nm

- 13 The diagram represents a stationary wave on a stretched string.

9702/01/O/N/04/Q27

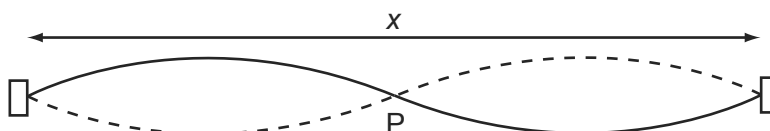

What is represented by point P and by the length  $x$ ?

	point P	length $x$
<b>A</b>	antinode	one wavelength
<b>B</b>	antinode	two wavelengths
<b>C</b>	node	one wavelength
<b>D</b>	node	two wavelengths

- 14 Fringes of separation  $y$  are observed on a screen 1.00 m from a Young's slit arrangement that is illuminated by yellow light of wavelength 600 nm.

9702/01/O/N/04/Q28

At which distance from the slits would fringes of the same separation  $y$  be observed when using blue light of wavelength 400 nm?

- A** 0.33 m      **B** 0.67 m      **C** 0.75 m      **D** 1.50 m
- 15 T is a microwave transmitter placed at a fixed distance from a flat reflecting surface S.

9702/01/M/J/05/Q27

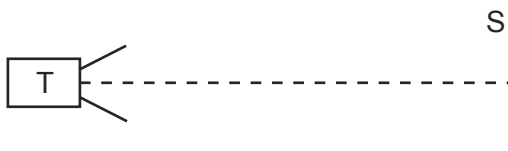

A small microwave receiver is moved steadily from T towards S and receives signals of alternate maxima and minima of intensity.

The distance between successive maxima is 15 mm.

What is the frequency of the microwaves?

- A**  $1.0 \times 10^7$  Hz  
**B**  $2.0 \times 10^7$  Hz  
**C**  $1.0 \times 10^{10}$  Hz  
**D**  $2.0 \times 10^{10}$  Hz
- 16 A narrow beam of monochromatic light is incident normally on a diffraction grating. Third-order diffracted beams are formed at angles of  $45^\circ$  to the original direction.

9702/01/O/N/07/Q25

What is the highest order of diffracted beam produced by this grating?

- A** 3rd      **B** 4th      **C** 5th      **D** 6th

- 17 A sound wave is set up in a long tube, closed at one end. The length of the tube is adjusted until the sound from the tube is loudest.

9702/01/M/J/05/Q26

What is the nature of the sound wave in the tube?

- A** longitudinal and progressive  
**B** longitudinal and stationary  
**C** transverse and progressive  
**D** transverse and stationary
- 18 A teacher sets up the apparatus shown to demonstrate a two-slit interference pattern on the screen.

9702/01/M/J/05/Q28

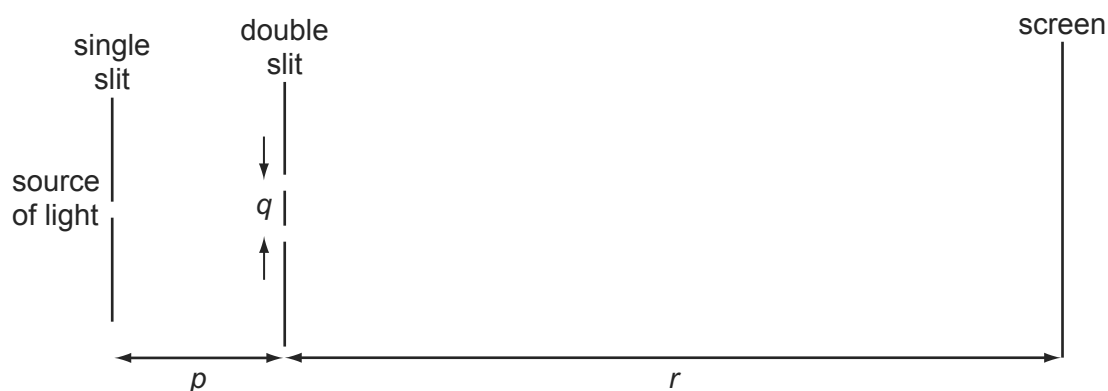

Which change to the apparatus will increase the fringe spacing?

- A** decreasing the distance  $p$   
**B** decreasing the distance  $q$   
**C** decreasing the distance  $r$   
**D** decreasing the wavelength of the light
- 19 A parallel beam of white light is incident normally on a diffraction grating. It is noted that the second-order and third-order spectra partially overlap.

9702/01/M/J/05/Q29

Which wavelength in the third-order spectrum appears at the same angle as the wavelength of 600 nm in the second-order spectrum?

- A** 300 nm      **B** 400 nm      **C** 600 nm      **D** 900 nm
- 20 Light of wavelength 700 nm is incident on a pair of slits, forming fringes 3.0 mm apart on a screen.

What is the fringe spacing when light of wavelength 350 nm is used and the slit separation is doubled?

9702/01/O/N/05/Q28

- A** 0.75 mm      **B** 1.5 mm      **C** 3.0 mm      **D** 6.0 mm

- 21 The graph represents a standing wave at two different times.

9702/01/O/N/05/Q26

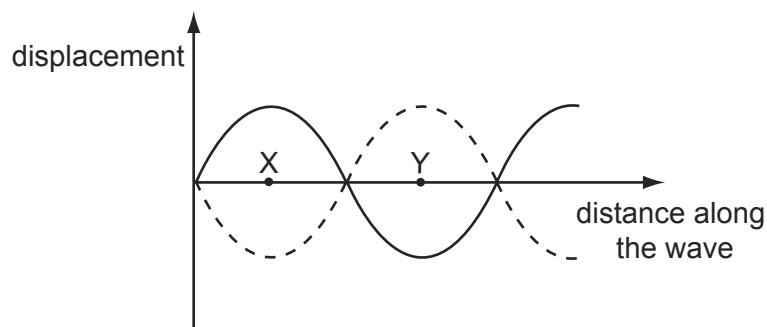

What does the distance XY represent?

- A** half the amplitude  
**B** half the frequency  
**C** half the period  
**D** half the wavelength
- 22 In which situation does diffraction occur? 9702/01/O/N/05/Q27
- A** A wave bounces back from a surface.  
**B** A wave passes from one medium into another.  
**C** A wave passes through an aperture.  
**D** Waves from two identical sources are superposed.
- 23 Where, in a standing wave, do the vibrations of the medium occur? 9702/01/M/J/06/Q26
- A** only at the nodes  
**B** only at the antinodes  
**C** at all points between the nodes  
**D** at all points between the antinodes
- 24 Monochromatic light is incident on a diffraction grating and a diffraction pattern is observed. Which line of the table gives the effect of replacing the grating with one that has more lines per metre? 9702/01/M/J/06/Q27

	number of orders of diffraction visible	angle between first and second orders of diffraction
<b>A</b>	decreases	decreases
<b>B</b>	decreases	increases
<b>C</b>	increases	decreases
<b>D</b>	increases	increases

25 A double-slit interference experiment is set up as shown.

9702/01/M/J/06/Q28

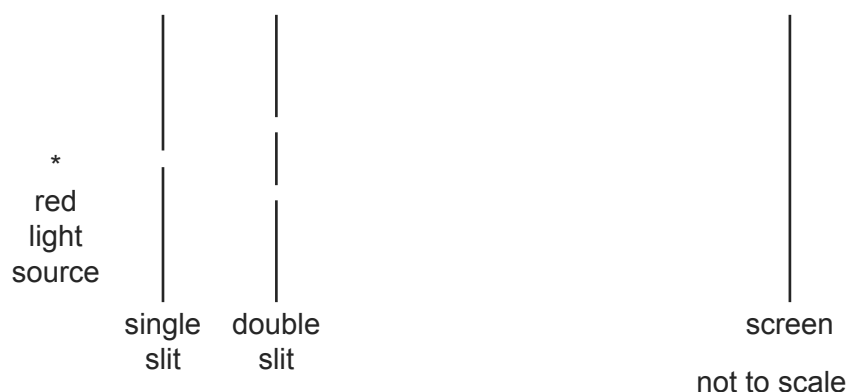

Fringes are formed on the screen. The distance between successive bright fringes is found to be 4 mm.

Two changes are then made to the experimental arrangement. The double slit is replaced by another double slit which has half the spacing. The screen is moved so that its distance from the double slit is twice as great.

What is now the distance between successive bright fringes?

- A** 1mm              **B** 4mm              **C** 8mm              **D** 16mm

26 Continuous water waves are diffracted through a gap in a barrier in a ripple tank.

9702/01/O/N/06/Q26

Which change will cause the diffraction of the waves to increase?

- A** increasing the frequency of the waves  
**B** increasing the width of the gap  
**C** reducing the wavelength of the waves  
**D** reducing the width of the gap

27 The interference patterns from a diffraction grating and a double slit are compared.

9702/01/O/N/06/Q27

Using the diffraction grating, yellow light of the first order is seen at  $30^\circ$  to the normal to the grating.

The same light produces interference fringes on a screen 1.0 m from the double slit. The slit separation is 500 times greater than the line spacing of the grating.

What is the fringe separation on the screen?

- A**  $2.5 \times 10^{-7}$  m  
**B**  $1.0 \times 10^{-5}$  m  
**C**  $1.0 \times 10^{-3}$  m  
**D**  $1.0 \times 10^{-1}$  m

28 What may be used to produce stationary waves?

9702/01/O/N/06/Q28

- A blowing air over the top of an empty bottle
- B making a loud sound near a mountain
- C passing monochromatic light through a double slit
- D passing water waves through a narrow slit

29 The diagram represents a stationary wave on a stretched string.

9702/01/M/J/07/Q25

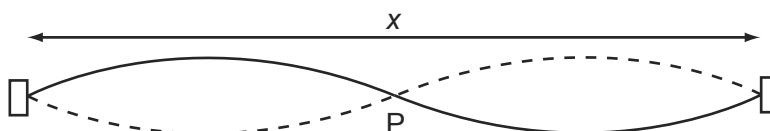

What is represented by point P and by the length x?

	point P	length x
<b>A</b>	antinode	one wavelength
<b>B</b>	antinode	two wavelengths
<b>C</b>	node	one wavelength
<b>D</b>	node	two wavelengths

30 A two-slit arrangement is set up to produce interference fringes on a screen. The fringes are too close together for convenient observation when a monochromatic source of violet light is used.

9702/01/M/J/07/Q26

In which way would it be possible to increase the separation of the fringes?

- A Decrease the distance between the screen and the slits.
- B Increase the distance between the two slits.
- C Increase the width of each slit.
- D Use a monochromatic source of red light.

31 Monochromatic light illuminates two narrow parallel slits. The interference pattern which results is observed on a screen some distance beyond the slits.

9702/01/O/N/07/Q24

Which change increases the separation between the dark lines of the interference pattern?

- A decreasing the distance between the screen and the slits
- B increasing the distance between the slits
- C using monochromatic light of higher frequency
- D using monochromatic light of longer wavelength



- 32 A stationary longitudinal wave is set up in a pipe.

9702/01/M/J/07/Q27

In the diagrams below, the length of each arrow represents the amplitude of the motion of the air molecules, and the arrow head shows the direction of motion at a particular instant.

Which diagram shows a stationary wave in which there are two nodes and two antinodes?

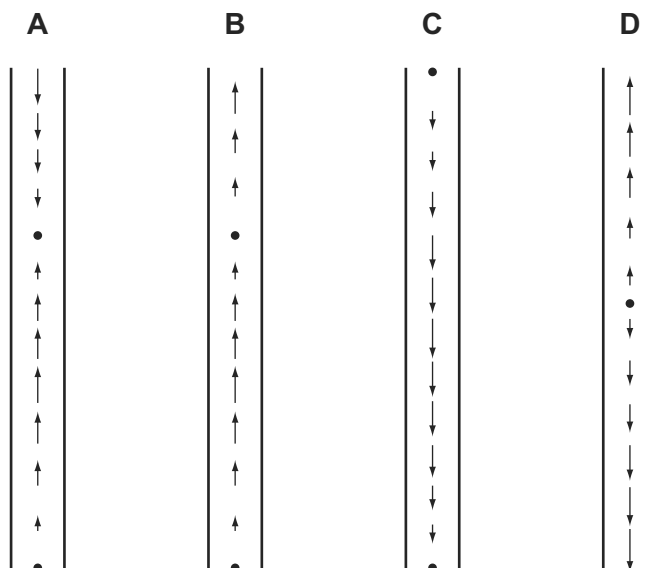

- 33 Sound waves, emitted by a small loudspeaker, are reflected by a wall.

9702/01/M/J/08/Q27

The frequency  $f$  of the waves is adjusted until a stationary wave is formed with the antinode nearest the wall at a distance  $x$  from the wall.

Which expression gives  $f$  in terms of  $x$  and the speed of sound  $c$ ?

- A**  $f = \frac{4c}{x}$       **B**  $f = \frac{2c}{x}$       **C**  $f = \frac{c}{2x}$       **D**  $f = \frac{c}{4x}$

- 34 A diffraction grating has  $N$  lines per unit length and is placed at  $90^\circ$  to monochromatic light of wavelength  $\lambda$ .

9702/01/M/J/08/Q28

What is the expression for  $\theta$ , the angle to the normal to the grating at which the third order diffraction peak is observed?

- A**  $\sin \theta = \frac{1}{3N\lambda}$       **B**  $\sin \theta = 3N\lambda$       **C**  $\sin \theta = \frac{N\lambda}{3}$       **D**  $\sin \theta = \frac{3\lambda}{N}$

- 35 Light of wavelength 700 nm is incident on a pair of slits, forming fringes 3.0 mm apart on a screen.

What is the fringe spacing when light of wavelength 350 nm is used and the slit separation is doubled?

9702/01/M/J/08/Q29

- A** 0.75 mm      **B** 1.5 mm      **C** 3.0 mm      **D** 6.0 mm

- 36 T is a microwave transmitter placed at a fixed distance from a flat reflecting surface S.

9702/01/O/N/08/Q27



A small microwave receiver is moved from T towards S and receives signals of alternate maxima and minima of intensity.

The distance between one maximum and the next is 15 mm.

What is the frequency of the microwaves?

- A**  $1.0 \times 10^7$  Hz  
**B**  $2.0 \times 10^7$  Hz  
**C**  $1.0 \times 10^{10}$  Hz  
**D**  $2.0 \times 10^{10}$  Hz
- 37 The diagram shows two loudspeakers producing sound waves that are in phase. 9702/01/O/N/08/Q28

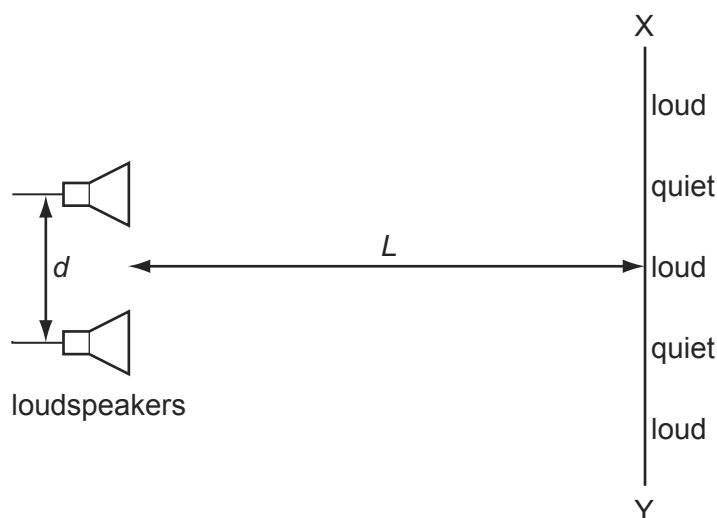

As a student moves from X to Y, the intensity of the note she hears is alternately loud and quiet.

The distance between adjacent loud and quiet regions may be reduced by

- A** decreasing distance  $d$ .  
**B** increasing distance  $L$ .  
**C** decreasing the amplitude.  
**D** increasing the frequency.

- 38 Diffraction is the name given to the
- A addition of two coherent waves to produce a stationary wave pattern.
  - B bending of waves round an obstacle.
  - C change of direction when waves cross the boundary between one medium and another.
  - D splitting of white light into colours.

- 39 The diagram represents the pattern of stationary waves formed by the superposition of sound waves from a loudspeaker and their reflection from a metal sheet (not shown). 9702/01/M/J/09/Q24

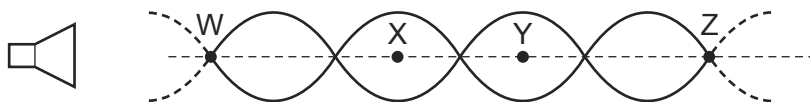

W, X, Y and Z are four points on the line through the centre of these waves.

Which statement about these stationary waves is correct?

- A An antinode is formed at the surface of the metal sheet.
  - B A node is a quarter of a wavelength from an adjacent antinode.
  - C The oscillations at X are in phase with those at Y.
  - D The stationary waves oscillate at right angles to the line WZ.
- 40 A diffraction grating with  $N$  lines per metre is used to deflect light of various wavelengths  $\lambda$ .

The diagram shows a relation between the deflection angles  $\theta$  for different values of  $\lambda$  in the  $n^{\text{th}}$  order interference pattern.

9702/01/M/J/09/Q25

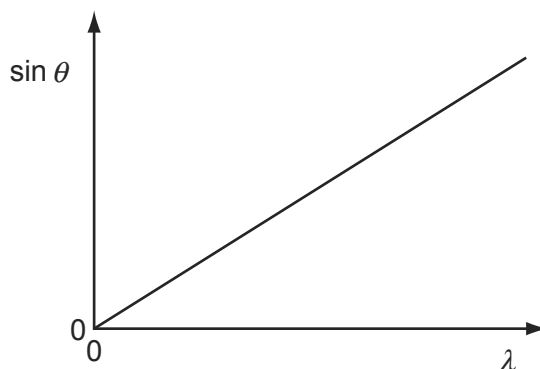

What is the gradient of the graph?

- A  $Nn$
  - B  $\frac{N}{n}$
  - C  $\frac{n}{N}$
  - D  $\frac{1}{Nn}$
- 41 A parallel beam of light of wavelength 450 nm falls normally on a diffraction grating which has 300 lines/mm. 9702/11/O/N/09/Q26
- What is the total number of transmitted maxima?
- A 7
  - B 8
  - C 14
  - D 15

- 42 A stationary wave of frequency  $80.0\text{ Hz}$  is set up on a stretched string of length  $210\text{ cm}$ .

9702/01/M/J/09/Q26

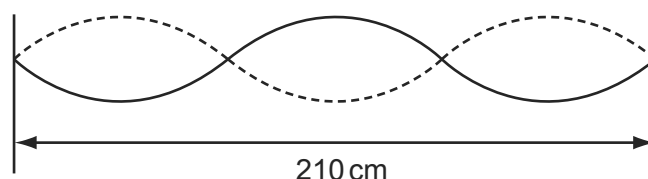

What is the speed of the waves that produce this stationary wave?

- A**  $56.0\text{ ms}^{-1}$       **B**  $112\text{ ms}^{-1}$       **C**  $5600\text{ ms}^{-1}$       **D**  $11\,200\text{ ms}^{-1}$
- 43 The diagram shows a standing wave on a string. The standing wave has three nodes  $N_1$ ,  $N_2$  and  $N_3$ .

9702/11/O/N/09/Q25

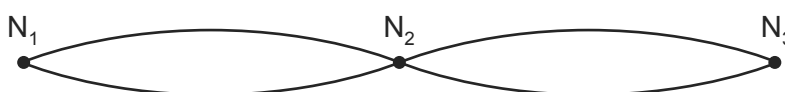

Which statement is correct?

- A** All points on the string vibrate in phase.  
**B** All points on the string vibrate with the same amplitude.  
**C** Points equidistant from  $N_2$  vibrate with the same frequency and in phase.  
**D** Points equidistant from  $N_2$  vibrate with the same frequency and the same amplitude.
- 44 The diagram shows a standing wave on a string. The standing wave has three nodes  $N_1$ ,  $N_2$  and  $N_3$ .

9702/12/O/N/09/Q24

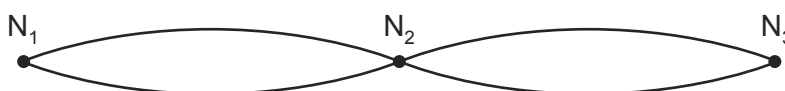

Which statement is correct?

- A** All points on the string vibrate in phase.  
**B** All points on the string vibrate with the same amplitude.  
**C** Points equidistant from  $N_2$  vibrate with the same frequency and in phase.  
**D** Points equidistant from  $N_2$  vibrate with the same frequency and the same amplitude.
- 45 A parallel beam of light of wavelength  $450\text{ nm}$  falls normally on a diffraction grating which has  $300\text{ lines/mm}$ .

9702/12/O/N/09/Q25

What is the total number of transmitted maxima?

- A** 7      **B** 8      **C** 14      **D** 15

- 46 Using monochromatic light, interference fringes are produced on a screen placed a distance  $D$  from a pair of slits of separation  $a$ . The separation of the fringes is  $x$ . 9702/11/M/J/10/Q23

Both  $a$  and  $D$  are now doubled.

What is the new fringe separation?

- A**  $\frac{x}{2}$                       **B**  $x$                       **C**  $2x$                       **D**  $4x$
- 47 Diagram 1 shows a ripple tank experiment in which plane waves are diffracted through a narrow slit in a metal sheet. 9702/11/M/J/10/Q24

Diagram 2 shows the same tank with a slit of greater width.

In each case, the pattern of the waves incident on the slit and the emergent pattern are shown.

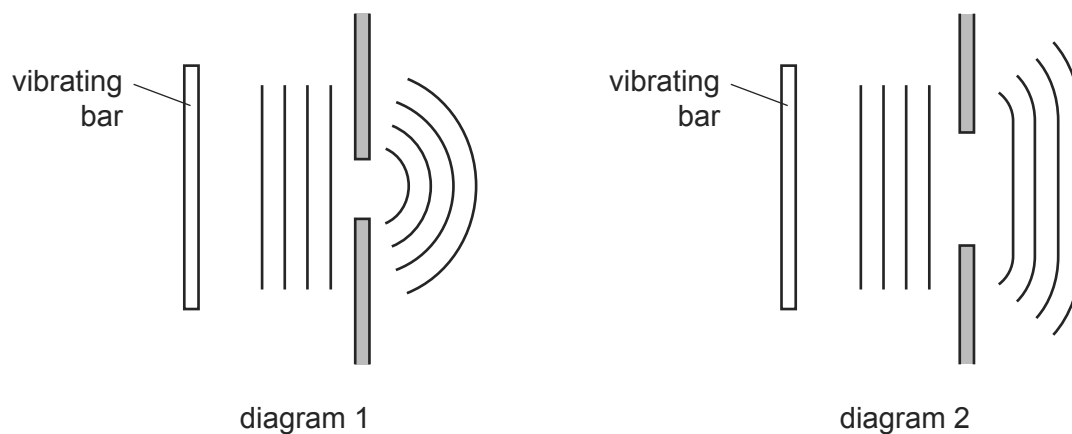

Which action would cause the waves in diagram 1 to be diffracted less and so produce an emergent pattern closer to that shown in diagram 2?

- A** increasing the frequency of vibration of the bar  
**B** increasing the speed of the waves by making the water in the tank deeper  
**C** reducing the amplitude of vibration of the bar  
**D** reducing the length of the vibrating bar
- 48 Electromagnetic waves from an unknown source in space were found to be significantly diffracted when passing through gaps of the order of  $10^{-5}$  m. 9702/12/M/J/10/Q24

Which type of wave are they most likely to be?

- A** radio waves  
**B** microwaves  
**C** infra-red waves  
**D** ultraviolet waves

- 49 The diagram shows a steel wire clamped at one end and tensioned at the other by a weight hung over a pulley.

9702/11/M/J/10/Q25

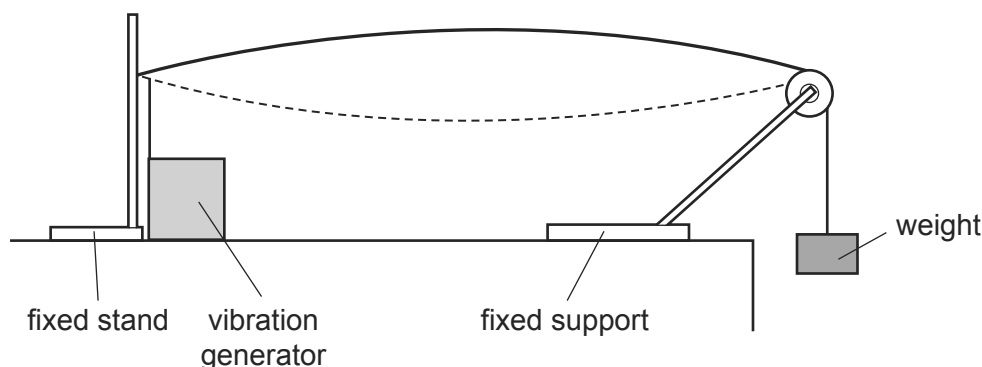

A vibration generator is attached to the wire near the clamped end. A stationary wave with one loop is produced. The frequency of the vibration generator is  $f$ .

Which frequency should be used to produce a stationary wave with two loops?

- A**  $\frac{f}{4}$       **B**  $\frac{f}{2}$       **C**  $2f$       **D**  $4f$
- 50 The diagram shows a steel wire clamped at one end and tensioned at the other by a weight hung over a pulley.

9702/12/M/J/10/Q22

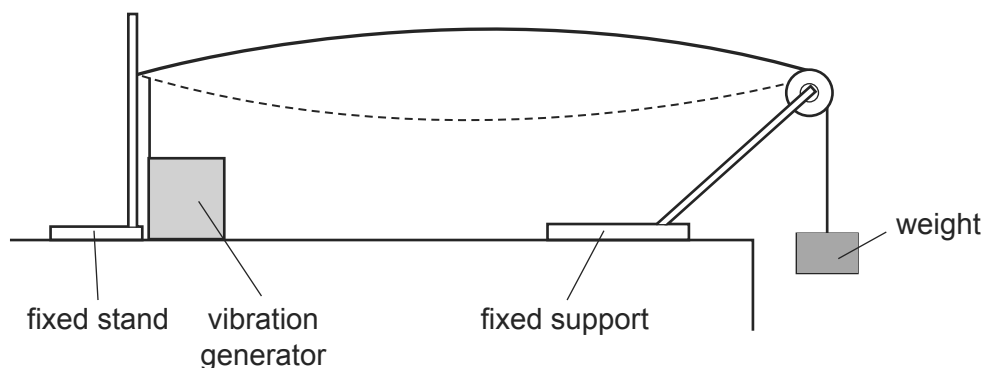

A vibration generator is attached to the wire near the clamped end. A stationary wave with one loop is produced. The frequency of the vibration generator is  $f$ .

Which frequency should be used to produce a stationary wave with two loops?

- A**  $\frac{f}{4}$       **B**  $\frac{f}{2}$       **C**  $2f$       **D**  $4f$
- 51 Using monochromatic light, interference fringes are produced on a screen placed a distance  $D$  from a pair of slits of separation  $a$ . The separation of the fringes is  $x$ .

9702/12/M/J/10/Q25

Both  $a$  and  $D$  are now doubled.

What is the new fringe separation?

- A**  $\frac{x}{2}$       **B**  $x$       **C**  $2x$       **D**  $4x$

- 52 Diagram 1 shows a ripple tank experiment in which plane waves are diffracted through a narrow slit in a metal sheet.

9702/12/M/J/10/Q23

Diagram 2 shows the same tank with a slit of greater width.

In each case, the pattern of the waves incident on the slit and the emergent pattern are shown.

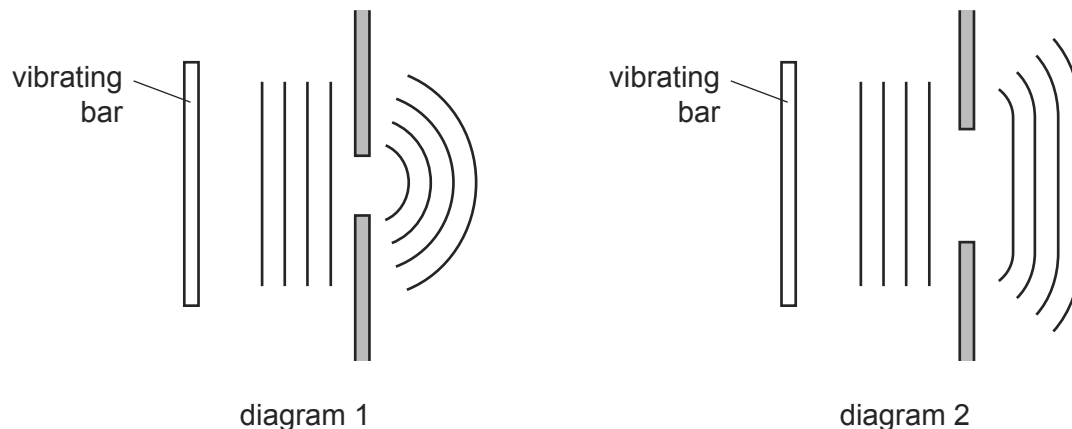

Which action would cause the waves in diagram 1 to be diffracted less and so produce an emergent pattern closer to that shown in diagram 2?

- A increasing the frequency of vibration of the bar
  - B increasing the speed of the waves by making the water in the tank deeper
  - C reducing the amplitude of vibration of the bar
  - D reducing the length of the vibrating bar
- 53 The diagram shows a steel wire clamped at one end and tensioned at the other by a weight hung over a pulley.

9702/13/M/J/10/Q24

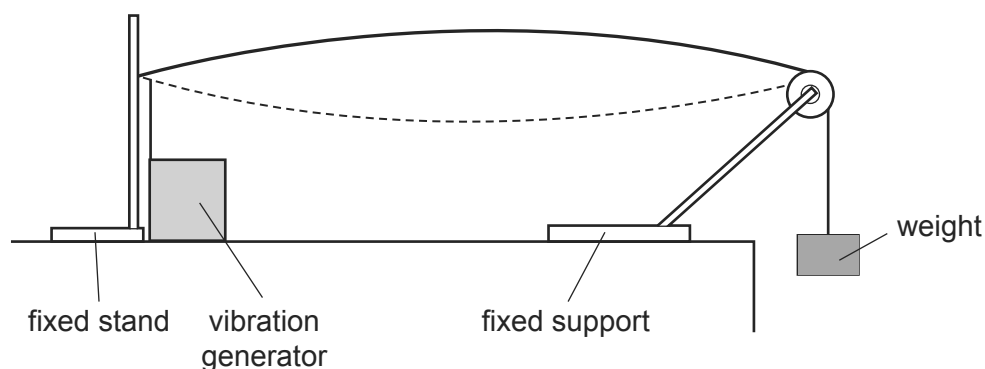

A vibration generator is attached to the wire near the clamped end. A stationary wave with one loop is produced. The frequency of the vibration generator is  $f$ .

Which frequency should be used to produce a stationary wave with two loops?

- A  $\frac{f}{4}$
- B  $\frac{f}{2}$
- C  $2f$
- D  $4f$

- 54 Electromagnetic waves from an unknown source in space were found to be significantly diffracted when passing through gaps of the order of  $10^{-5}$  m. 9702/13/M/J/10/Q23

Which type of wave are they most likely to be?

- A radio waves  
 B microwaves  
 C infra-red waves  
 D ultraviolet waves
- 55 Diagram 1 shows a ripple tank experiment in which plane waves are diffracted through a narrow slit in a metal sheet. 9702/13/M/J/10/Q25

Diagram 2 shows the same tank with a slit of greater width.

In each case, the pattern of the waves incident on the slit and the emergent pattern are shown.

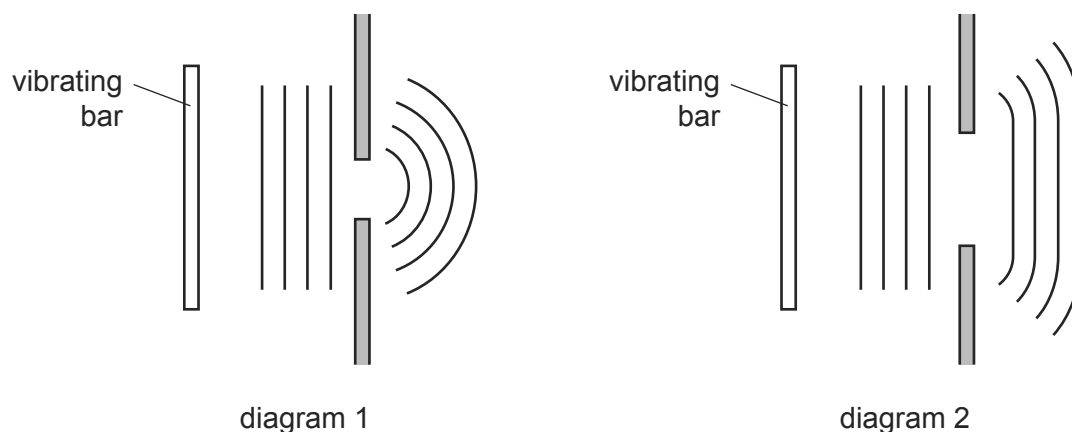

Which action would cause the waves in diagram 1 to be diffracted less and so produce an emergent pattern closer to that shown in diagram 2?

- A increasing the frequency of vibration of the bar  
 B increasing the speed of the waves by making the water in the tank deeper  
 C reducing the amplitude of vibration of the bar  
 D reducing the length of the vibrating bar
- 56 Which electromagnetic wave would cause the most significant diffraction effect for an atomic lattice of spacing around  $10^{-10}$  m? 9702/11/O/N/10/Q27
- A infra-red  
 B microwave  
 C ultraviolet  
 D X-ray



- 57 A stationary wave is produced by two loudspeakers emitting sound of the same frequency.

9702/11/O/N/10/Q26

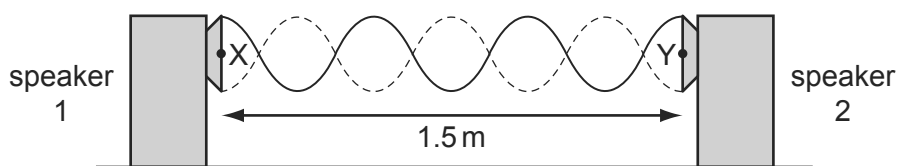

When a microphone is moved between X and Y, a distance of 1.5 m, six nodes and seven antinodes are detected.

What is the wavelength of the sound?

- A 0.50 m      B 0.43 m      C 0.25 m      D 0.21 m
- 58 The diagram shows two tubes.

9702/12/O/N/10/Q25

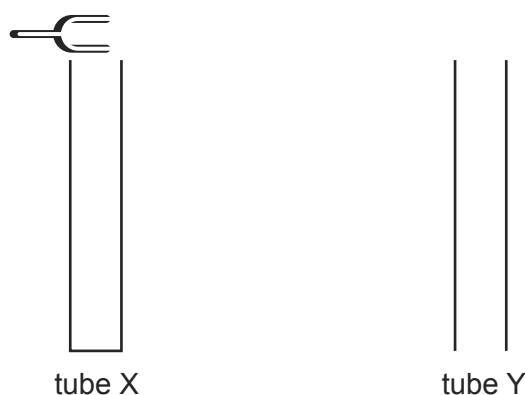

The tubes are identical except tube X is closed at its lower end while tube Y is open at its lower end. Both tubes have open upper ends.

A tuning fork placed above tube X causes resonance of the air at frequency  $f$ . No resonance is found at any **lower** frequency than  $f$  with tube X.

Which tuning fork will produce resonance when placed just above tube Y?

- A a fork of frequency  $\frac{f}{2}$
- B a fork of frequency  $\frac{2f}{3}$
- C a fork of frequency  $\frac{3f}{2}$
- D a fork of frequency  $2f$
- 59 Which electromagnetic wave phenomenon is needed to explain the spectrum produced when white light falls on a diffraction grating?

9702/11/M/J/11/Q26

- A coherence
- B interference
- C polarisation
- D refraction

- 60 A microwave transmitter emits waves towards a metal plate. The waves strike the plate and are reflected back along their original path.

9702/12/O/N/10/Q26



A microwave detector is moved along the line PT.

Points P, Q, R, S and T are the positions where minima of intensity are observed. These points are found to be 15 mm apart.

What is the frequency of the microwaves?

- A** 5.0 GHz      **B** 6.7 GHz      **C** 10 GHz      **D** 20 GHz
- 61 A double slit experiment, using light of wavelength 600 nm, results in fringes being produced on a screen. The fringe separation is found to be 1.0 mm.

9702/12/O/N/10/Q27

When the distance between the double slits and the viewing screen is increased **by** 2.0 m, the fringe separation increases **to** 3.0 mm.

What is the separation of the double slits producing the fringes?

- A** 0.4 mm      **B** 0.6 mm      **C** 0.9 mm      **D** 1.2 mm
- 62 A stationary wave is produced by two loudspeakers emitting sound of the same frequency.

9702/13/O/N/10/Q23

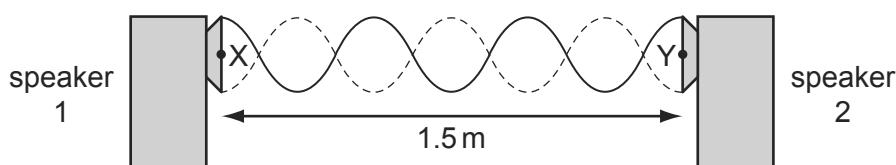

When a microphone is moved between X and Y, a distance of 1.5 m, six nodes and seven antinodes are detected.

What is the wavelength of the sound?

- A** 0.50 m      **B** 0.43 m      **C** 0.25 m      **D** 0.21 m
- 63 Which electromagnetic wave would cause the most significant diffraction effect for an atomic lattice of spacing around  $10^{-10}$  m?

9702/13/O/N/10/Q26

- A** infra-red  
**B** microwave  
**C** ultraviolet  
**D** X-ray

- 64 The basic principle of note production in a horn is to set up a stationary wave in an air column.

9702/11/M/J/11/Q25

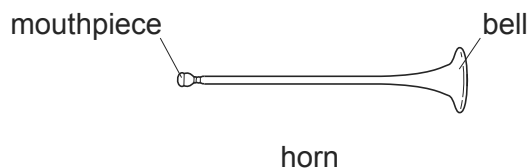

For the lowest note produced by a horn, a node is formed at the mouthpiece and the antinode is formed at the bell. The frequency of this note is 75 Hz.

What are the frequencies of the next two higher notes for this air column?

	first higher note /Hz	second higher note /Hz
<b>A</b>	113	150
<b>B</b>	150	225
<b>C</b>	150	300
<b>D</b>	225	375

- 65 The diagrams show the arrangement of apparatus for a Young's slits experiment and also part of the pattern formed on the screen with a ruler placed next to it.

9702/12/M/J/11/Q29

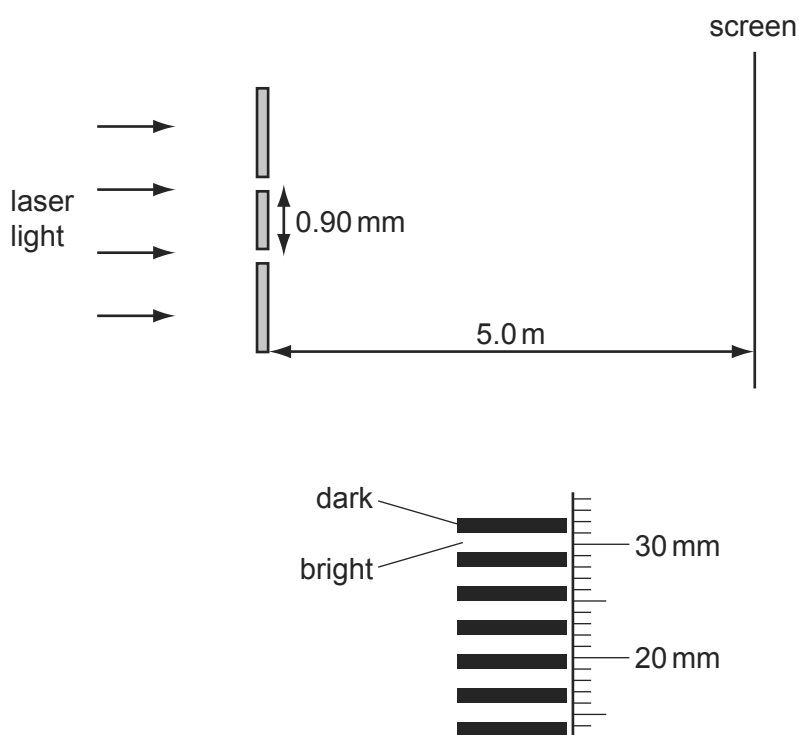

What is the wavelength of the light?

- A**  $4.8 \times 10^{-7} \text{ m}$     **B**  $5.4 \times 10^{-7} \text{ m}$     **C**  $3.2 \times 10^{-6} \text{ m}$     **D**  $3.4 \times 10^{-6} \text{ m}$

- 66 Coherent waves are produced at P and at Q and travel outwards in all directions. The line RS is halfway between P and Q and perpendicular to the line joining P and Q. The distance RS is much greater than the distance PQ.

9702/11/O/N/11/Q30

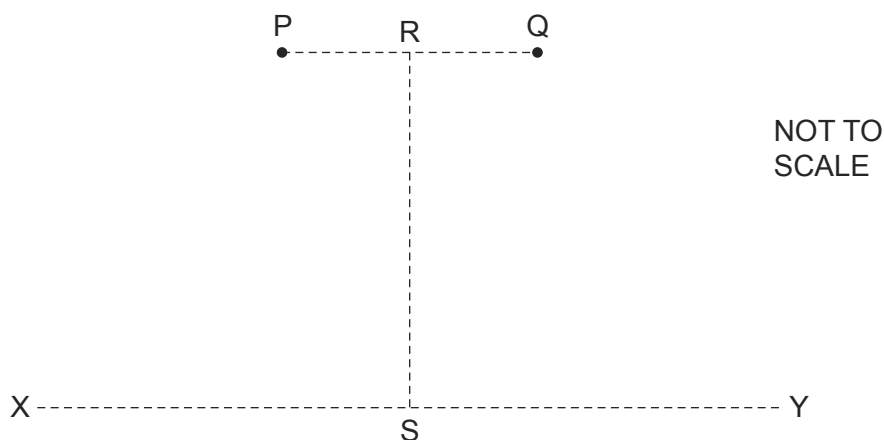

Along which line, or lines, is an interference pattern observed?

- A** both RS and XY  
**B** RS only  
**C** XY only  
**D** neither RS nor XY
- 67 A diffraction grating with 500 lines per mm is used to observe diffraction of monochromatic light of wavelength 600 nm.

9702/13/M/J/11/Q26

The light is passed through a narrow slit and the grating is placed so that its lines are parallel to the slit. Light passes through the slit and then the grating.

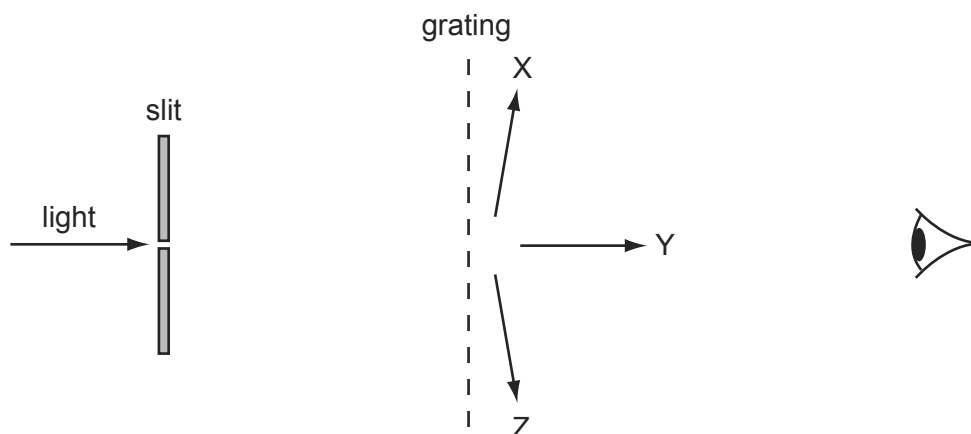

An observer views the slit through the grating at different angles, moving his head from X parallel to the grating, through Y, opposite the slit, to Z parallel to the grating on the opposite side.

How many images of the slit does he see?

- A** 3                      **B** 4                      **C** 6                      **D** 7

- 68 The basic principle of note production in a horn is to set up a stationary wave in an air column.

9702/13/M/J/11/Q27

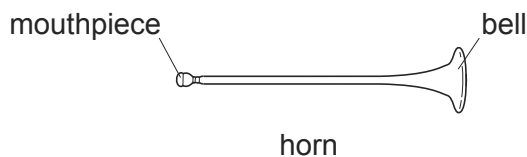

For the lowest note produced by a horn, a node is formed at the mouthpiece and the antinode is formed at the bell. The frequency of this note is 75 Hz.

What are the frequencies of the next two higher notes for this air column?

	first higher note / Hz	second higher note / Hz
<b>A</b>	113	150
<b>B</b>	150	225
<b>C</b>	150	300
<b>D</b>	225	375

- 69 Travelling waves of wavelength 20 cm are created in the air columns in a closed pipe P and an open pipe Q. The lengths of the pipes are shown.

9702/11/O/N/11/Q29

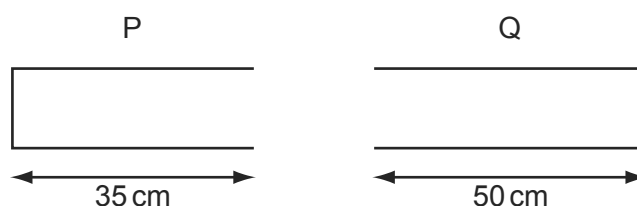

In which pipe or pipes are stationary waves formed?

- A** P and Q  
**B** P only  
**C** Q only  
**D** neither P nor Q
- 70 Two light sources produce visible interference fringes only in certain circumstances. 9702/12/O/N/11/Q28

Which condition enables visible interference fringes to be formed?

- A** using a white light source  
**B** using incoherent sources  
**C** using one light source which is polarised at right angles to light from the other source  
**D** using sources from which the light does not overlap

71 In which situation does diffraction occur?

9702/12/M/J/11/Q28

- A A wave bounces back from a surface.
- B A wave passes from one medium into another.
- C A wave passes through an aperture.
- D Waves from two identical sources are superposed.

72 Which electromagnetic wave phenomenon is needed to explain the spectrum produced when white light falls on a diffraction grating?

9702/13/M/J/11/Q25

- A coherence
- B interference
- C polarisation
- D refraction

73 A sound wave is set up in a long tube, closed at one end. The length of the tube is adjusted until the sound from the tube is loudest.

9702/12/O/N/11/Q27

What is the nature of the sound wave in the tube?

- A longitudinal and progressive
- B longitudinal and stationary
- C transverse and progressive
- D transverse and stationary

74 Travelling waves of wavelength 20 cm are created in the air columns in a closed pipe P and an open pipe Q. The lengths of the pipes are shown.

9702/13/O/N/11/Q30

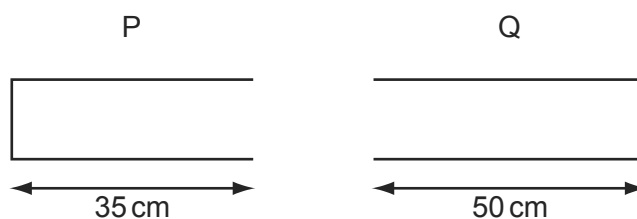

In which pipe or pipes are stationary waves formed?

- A P and Q
- B P only
- C Q only
- D neither P nor Q

- 75 A monochromatic plane wave of speed  $c$  and wavelength  $\lambda$  is diffracted at a small aperture.

9702/12/M/J/12/Q29

The diagram illustrates successive wavefronts.

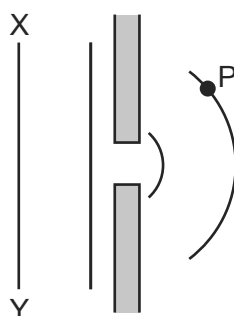

After what time will some portion of the wavefront XY reach point P?

- A  $\frac{3\lambda}{2c}$       B  $\frac{2\lambda}{c}$       C  $\frac{3\lambda}{c}$       D  $\frac{4\lambda}{c}$
- 76 A diffraction grating is used to measure the wavelength of monochromatic light, as shown in the diagram.

9702/11/M/J/12/Q30

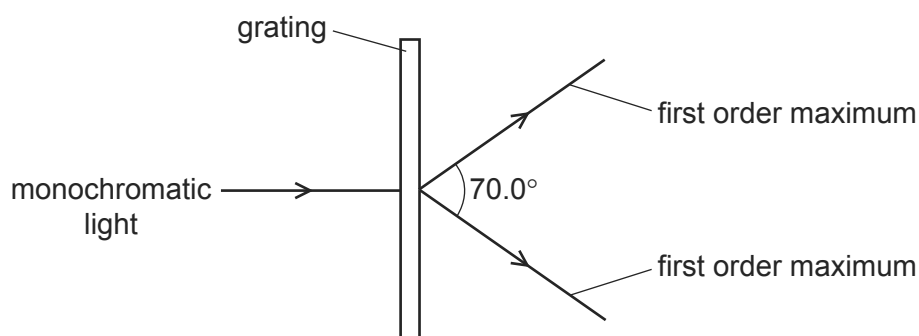

The spacing of the slits in the grating is  $1.00 \times 10^{-6}$  m. The angle between the first order diffraction maxima is  $70.0^\circ$ .

What is the wavelength of the light?

- A 287 nm      B 470 nm      C 574 nm      D 940 nm
- 77 To produce a stationary wave, two waves must travel in opposite directions through the same space.

9702/13/M/J/12/Q30

Which statement about the properties of the two waves must also be true?

- A The waves must have equal frequency, but a different speed and wavelength.  
 B The waves must have equal speed, but a different wavelength and frequency.  
 C The waves must have equal speed, frequency and wavelength.  
 D The waves must have equal wavelength, but a different speed and frequency.

- 78 A standing sound wave is set up between a loudspeaker and a wall.

9702/12/M/J/12/Q30

A microphone is connected to a cathode-ray oscilloscope (c.r.o.) and is moved along a line directly between the loudspeaker and the wall. The amplitude of the trace on the c.r.o. rises to a maximum at a position X, falls to a minimum and then rises once again to a maximum at a position Y.

The distance between X and Y is 33 cm. The speed of sound in air is  $330 \text{ m s}^{-1}$ .

Which diagram represents the c.r.o. trace of the sound received at X?

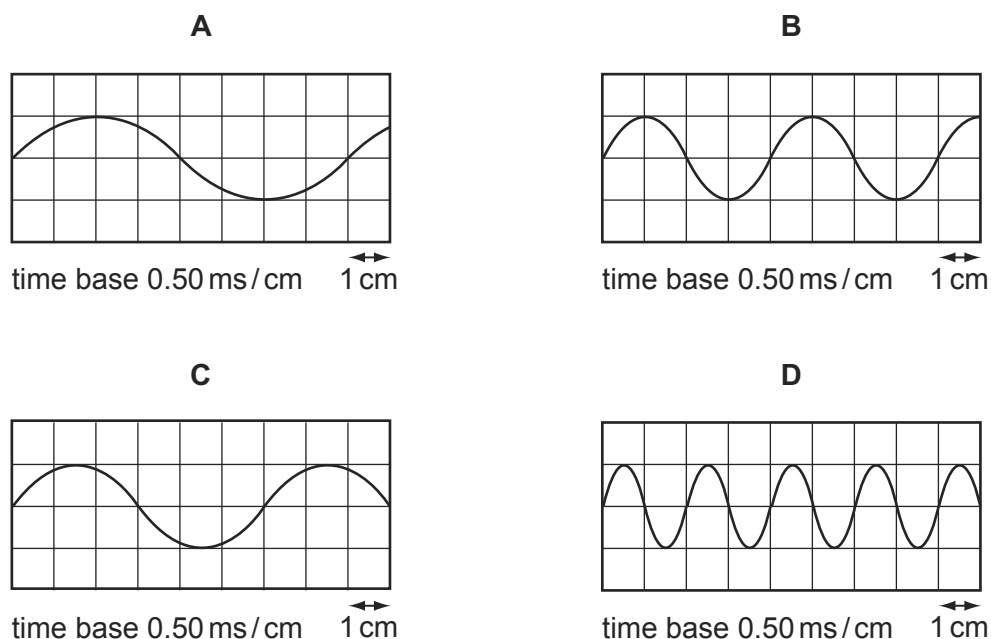

- 79 A diffraction grating is used to measure the wavelength of monochromatic light, as shown in the diagram.

9702/13/M/J/12/Q28

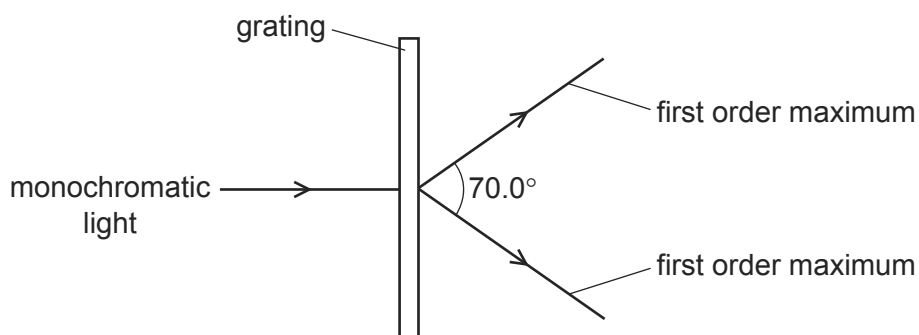

The spacing of the slits in the grating is  $1.00 \times 10^{-6} \text{ m}$ . The angle between the first order diffraction maxima is  $70.0^\circ$ .

What is the wavelength of the light?

- A** 287 nm      **B** 470 nm      **C** 574 nm      **D** 940 nm



- 80 Coherent waves are produced at P and at Q and travel outwards in all directions. The line RS is halfway between P and Q and perpendicular to the line joining P and Q. The distance RS is much greater than the distance PQ.

9702/13/O/N/11/Q29

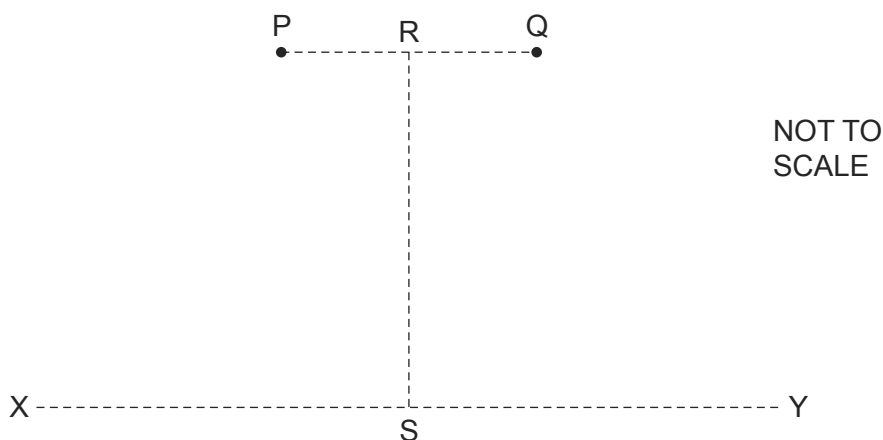

Along which line, or lines, is an interference pattern observed?

- A** both RS and XY  
**B** RS only  
**C** XY only  
**D** neither RS nor XY
- 81 To produce a stationary wave, two waves must travel in opposite directions through the same space.

9702/11/M/J/12/Q29

Which statement about the properties of the two waves must also be true?

- A** The waves must have equal frequency, but a different speed and wavelength.  
**B** The waves must have equal speed, but a different wavelength and frequency.  
**C** The waves must have equal speed, frequency and wavelength.  
**D** The waves must have equal wavelength, but a different speed and frequency.
- 82 A musical organ produces notes by blowing air into a set of pipes that are open at one end and closed at the other.

9702/11/O/N/12/Q28

What is the lowest frequency of sound produced by a pipe of length 10m?  
 (The speed of sound in the pipe is  $320 \text{ m s}^{-1}$ .)

- A** 4 Hz      **B** 8 Hz      **C** 16 Hz      **D** 32 Hz

- 83 The diagram shows two identical loudspeakers driven in phase by a common audio-frequency source.

9702/12/O/N/12/Q28

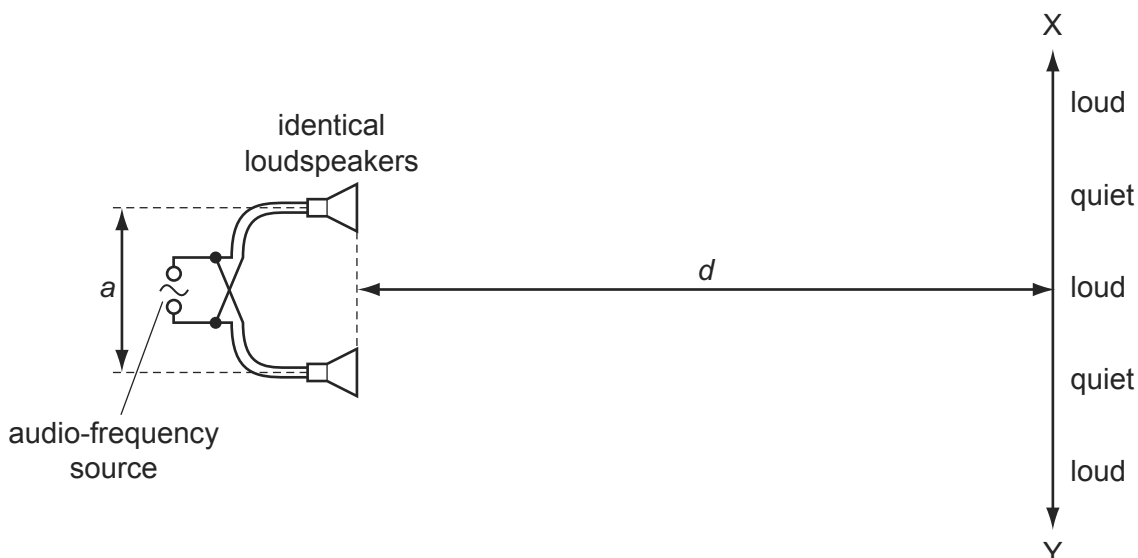

When a student moves along line  $XY$ , she notices that there are variations in the loudness of the sound. The regions in which the sound is heard are alternately loud and quiet as indicated on the diagram.

How may the distance between loud regions be reduced?

- A** decreasing the distance  $a$  between the speakers  
**B** increasing distance  $d$   
**C** increasing the frequency of the audio-frequency source  
**D** increasing the power output from the audio-frequency source
- 84 A horizontal glass tube, closed at one end, has a layer of dust laid inside it on its lower side. Sound is emitted from a loudspeaker that is placed near the open end of the tube. 9702/12/O/N/12/Q29

The frequency of the sound is varied and, at one frequency, a stationary wave is formed inside the tube so that the dust forms small heaps.

The distance between four heaps of dust is 30 cm.

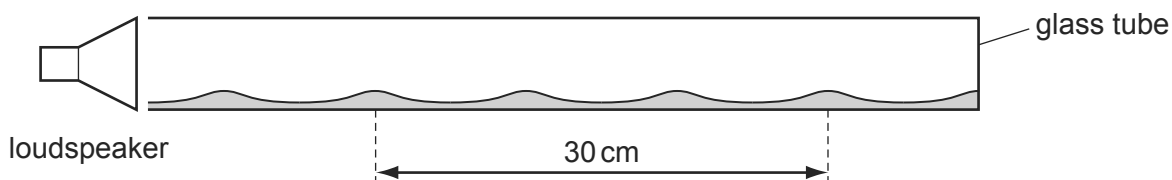

The speed of sound in the tube is  $330 \text{ m s}^{-1}$ .

What is the frequency of the sound emitted by the loudspeaker?

- A** 1650 Hz      **B** 2200 Hz      **C** 3300 Hz      **D** 6600 Hz

- 85 Monochromatic light of wavelength 690 nm passes through a diffraction grating with 300 lines per mm, producing a series of maxima on a screen.

9702/12/O/N/12/Q30

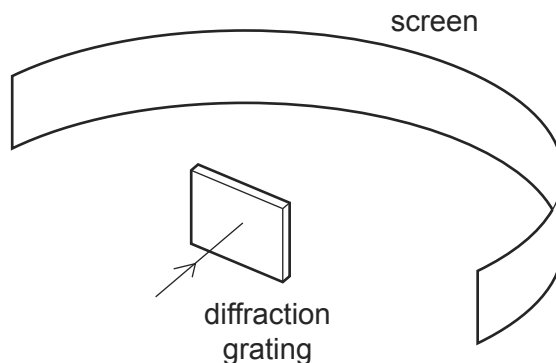

What is the greatest number of maxima that can be observed?

- A** 4                      **B** 5                      **C** 8                      **D** 9
- 86 Monochromatic light is directed at a diffraction grating as shown.

9702/11/O/N/12/Q29

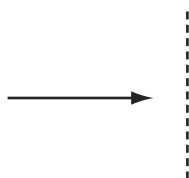

Which diagram shows all the possible directions of the light, after passing through the grating, that give maximum intensity?

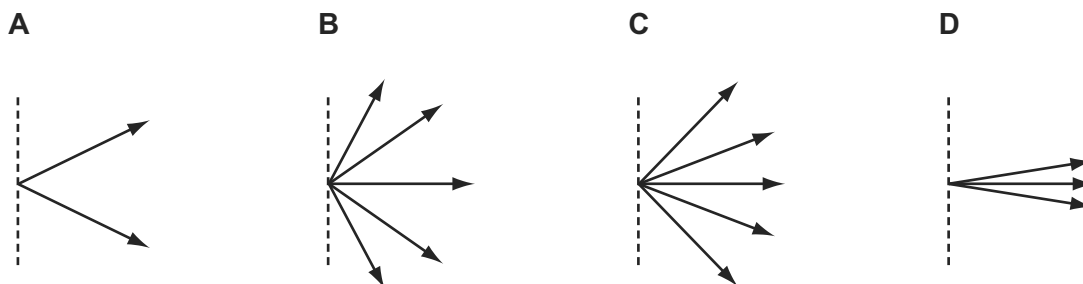

- 87 Diffraction can be observed when a wave passes an obstruction. The diffraction effect is greatest when the wavelength and the obstruction are similar in size.

9702/13/O/N/12/Q28

For waves travelling through air, what is the combination of wave and obstruction that could best demonstrate diffraction?

- A** microwaves passing a steel post  
**B** radio waves passing a copper wire  
**C** sound waves passing a human hair  
**D** visible light waves passing a gate post

- 88 The diagram shows an air-filled pipe open at both ends. The length of the pipe is 1.00 m and the lower surface of the inside of the pipe is covered with a layer of fine sand. 9702/13/O/N/12/Q26

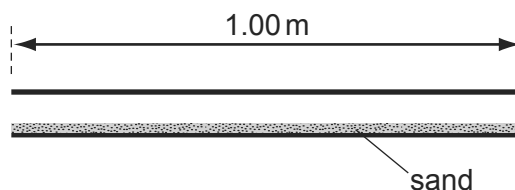

When a source of sound of a single frequency is put near one end of the pipe, the air in the pipe is found to resonate and a pattern in the sand shows that a standing wave containing three nodes is formed within the pipe.

The speed of sound in air is  $330 \text{ m s}^{-1}$ .

What is the frequency of the sound?

- A** 330 Hz      **B** 495 Hz      **C** 990 Hz      **D** 1320 Hz
- 89 A stationary sound wave is formed in a measuring cylinder by blowing across the top, as shown. 9702/13/O/N/12/Q27



Which statement is correct?

- A** The fundamental frequency of the stationary wave decreases when some water is added to the cylinder.
- B** The stationary wave in the cylinder is caused by the superposition of two waves moving in opposite directions.
- C** The stationary wave in the cylinder is polarised.
- D** The stationary wave will have an antinode at the bottom of the cylinder.
- 90 A parallel beam of red light of wavelength 700 nm is incident normally on a diffraction grating that has 400 lines per millimetre. 9702/13/M/J/13/Q27

What is the total number of transmitted maxima?

- A** 3      **B** 4      **C** 6      **D** 7

- 91 Monochromatic light of wavelength  $5.30 \times 10^{-7} \text{ m}$  is incident normally on a diffraction grating. The first order maximum is observed at an angle of  $15.4^\circ$  to the direction of the incident light.

What is the angle between the first and second order diffraction maxima?

9702/12/M/J/13/Q29

- A**  $7.6^\circ$       **B**  $15.4^\circ$       **C**  $16.7^\circ$       **D**  $32.0^\circ$

- 92 A transmitter of electromagnetic waves is placed 45 cm from a reflective surface.

9702/12/M/J/13/Q27

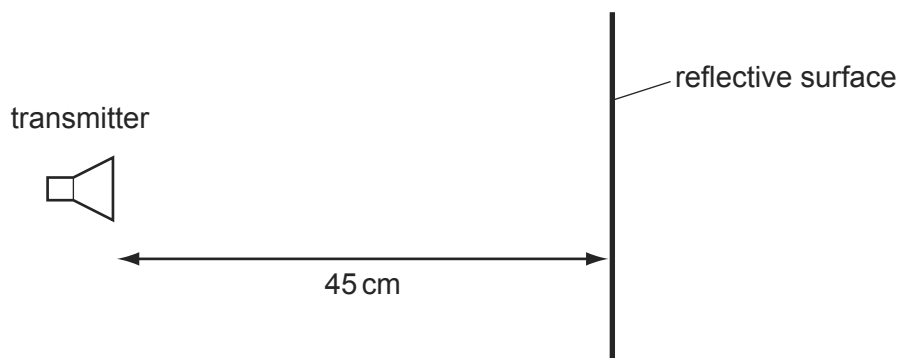

The emitted waves have a frequency of 1.00 GHz. A stationary wave is produced with a node at the transmitter and a node at the surface.

How many antinodes are in the space between the transmitter and the surface?

- A** 1      **B** 2      **C** 3      **D** 4

- 93 A teacher sets up the apparatus shown to demonstrate a two-slit interference pattern on the screen.

9702/12/M/J/13/Q28

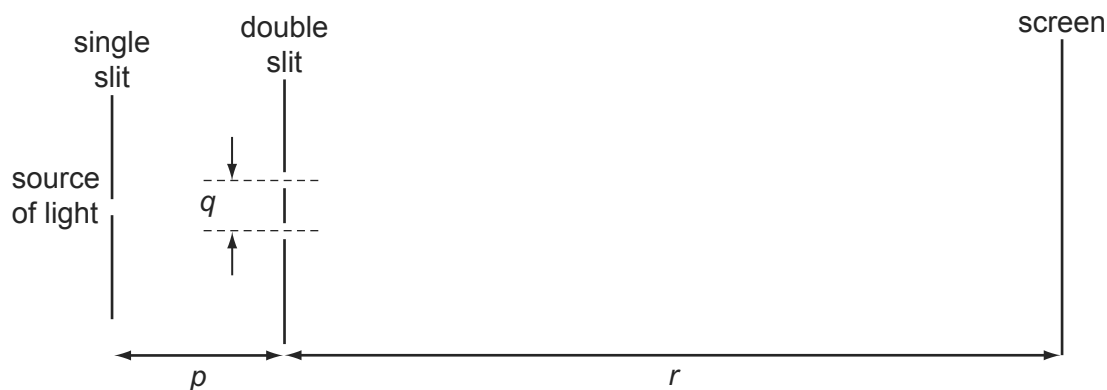

Which change to the apparatus will increase the fringe spacing?

- A** decreasing the distance  $p$   
**B** decreasing the distance  $q$   
**C** decreasing the distance  $r$   
**D** decreasing the wavelength of the light

- 94 The diagram shows a standing wave on a string. The standing wave has three nodes  $N_1$ ,  $N_2$  and  $N_3$ .

9702/13/M/J/13/Q28

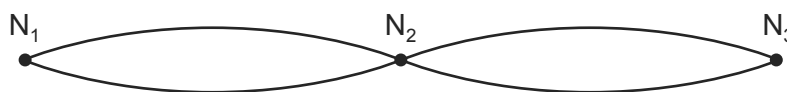

Which statement is correct?

- A All points on the string vibrate in phase.
  - B All points on the string vibrate with the same amplitude.
  - C Points equidistant from  $N_2$  vibrate with the same frequency and in phase.
  - D Points equidistant from  $N_2$  vibrate with the same frequency and the same amplitude.
- 95 Light of wavelength 600 nm is incident on a pair of slits. Fringes with a spacing of 4.0 mm are formed on a screen.

9702/11/M/J/13/Q27

What will be the fringe spacing when the wavelength of the light is changed to 400 nm and the separation of the slits is doubled?

- A 1.3 mm
  - B 3.0 mm
  - C 5.3 mm
  - D 12 mm
- 96 The speed of a transverse wave on a stretched string can be changed by adjusting the tension of the string. A stationary wave pattern is set up on a stretched string using an oscillator set at a frequency of 650 Hz.

9702/11/M/J/13/Q28

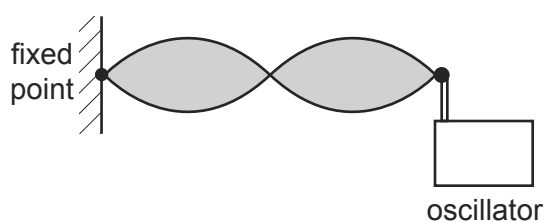

How must the wave be changed to maintain the same stationary wave pattern if the applied frequency is increased to 750 Hz?

- A Decrease the speed of the wave on the string.
- B Decrease the wavelength of the wave on the string.
- C Increase the speed of the wave on the string.
- D Increase the wavelength of the wave on the string.

- 97 Noise reduction headphones actively produce their own sound waves in order to cancel out external sound waves.

9702/11/M/J/13/Q29

A microphone in the headphones receives waves of one frequency. A loudspeaker in the headphones then produces a wave of that frequency but of a different phase.

What is the phase difference between the external sound wave and the wave produced by the loudspeaker in the headphones?

- A**  $90^\circ$       **B**  $180^\circ$       **C**  $270^\circ$       **D**  $360^\circ$

- 98 The sound from a loudspeaker placed above a tube causes resonance of the air in the tube.

9702/11/O/N/13/Q27

A stationary wave is formed with two nodes and two antinodes as shown.

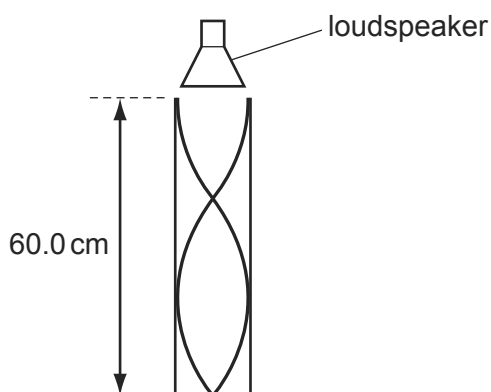

The speed of sound in air is  $330 \text{ m s}^{-1}$ .

What is the frequency of the sound?

- A** 413 Hz      **B** 550 Hz      **C** 830 Hz      **D** 1650 Hz

- 99 Light of wavelength  $\lambda$  passes through a diffraction grating with slit spacing  $d$ . A series of lines is observed on a screen.

9702/11/O/N/13/Q28

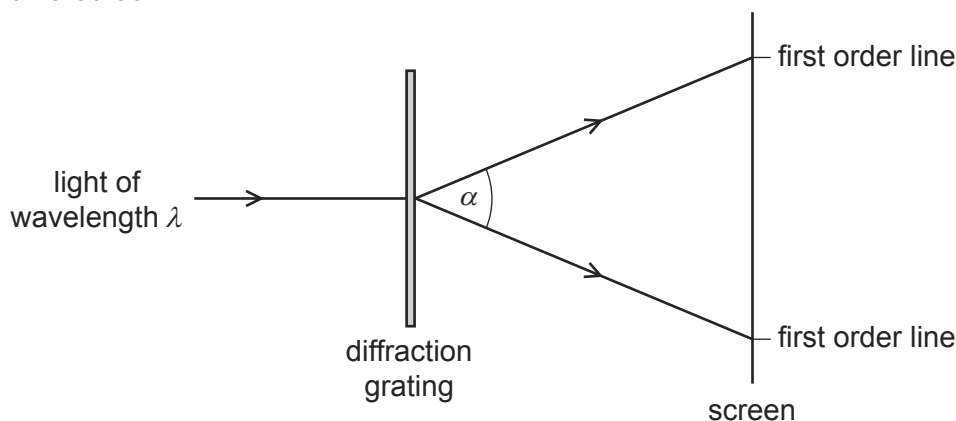

What is the angle  $\alpha$  between the two first order lines?

- A**  $\sin^{-1}\left(\frac{\lambda}{2d}\right)$       **B**  $\sin^{-1}\left(\frac{\lambda}{d}\right)$       **C**  $2\sin^{-1}\left(\frac{\lambda}{2d}\right)$       **D**  $2\sin^{-1}\left(\frac{\lambda}{d}\right)$

100 A student connects two loudspeakers to a signal generator.

9702/11/O/N/13/Q29

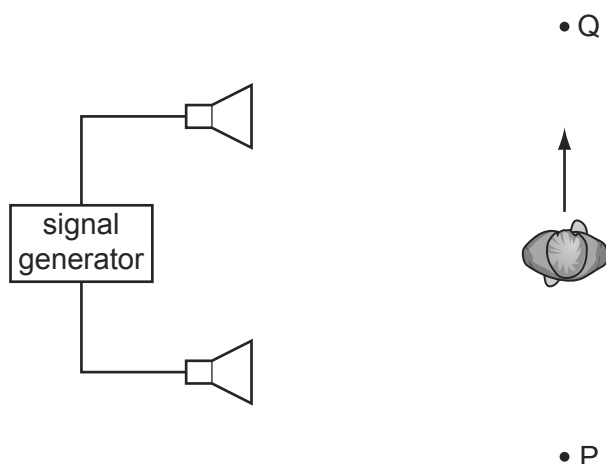

As the student walks from P to Q, he notices that the loudness of the sound rises and falls repeatedly.

What causes the loudness of the sound to vary?

- A diffraction of the sound waves
- B interference of the sound waves
- C polarisation of the sound waves
- D reflection of the sound waves

101 The three waves shown in each diagram have the same amplitude and frequency but differ in phase.

9702/13/O/N/13/Q26

They are added together to give a resultant wave.

In which case is the resultant wave zero?

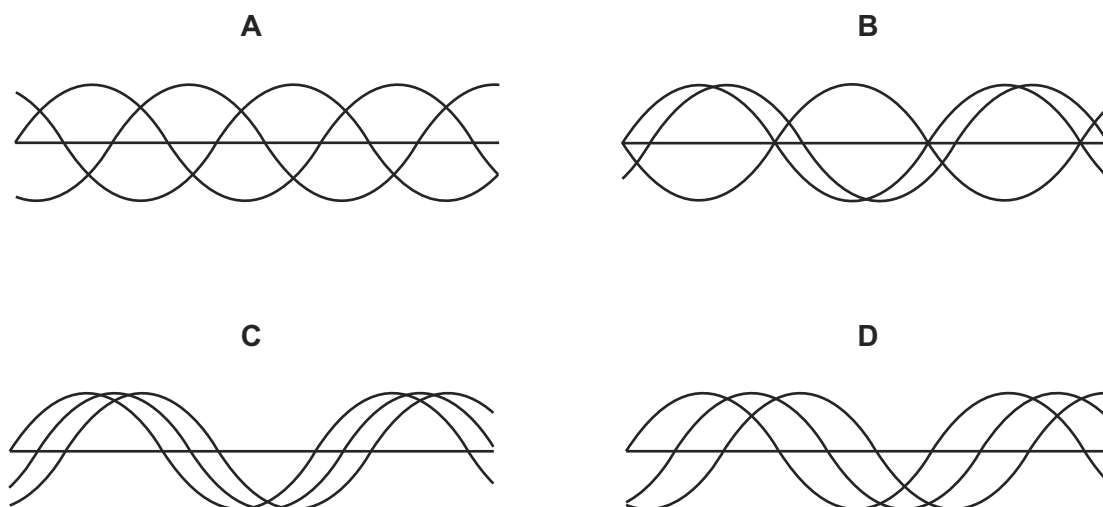

## Superposition



- 102 A student sets up apparatus to observe the double-slit interference of monochromatic light, as shown.

9702/13/O/N/13/Q29

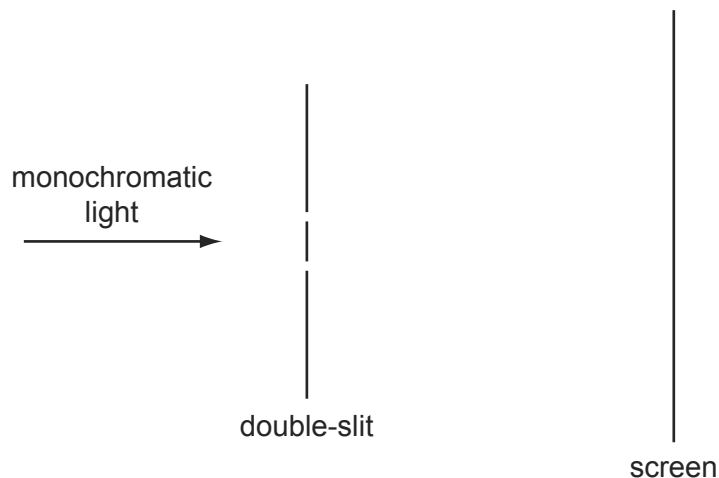

Interference fringes are formed on the screen.

Which change would increase the distance between adjacent fringes?

- A Decrease the distance between the two slits.
  - B Decrease the width of each slit.
  - C Move the screen closer to the double-slit.
  - D Use light of a higher frequency.
- 103 A stationary sound wave has a series of nodes. The distance between the first and the sixth node is 30.0 cm.

9702/13/O/N/13/Q27

What is the wavelength of the sound wave?

- A 5.0 cm      B 6.0 cm      C 10.0 cm      D 12.0 cm

- 104 What is meant by diffraction?

9702/13/O/N/13/Q28

- A Addition of two coherent waves to produce a stationary wave pattern.
- B Bending of waves round an obstacle.
- C Change of direction when waves cross the boundary between one medium and another.
- D Splitting of white light into colours.

- 105 A student attempts to show the interference of light using two identical green LEDs. 9702/13/M/J/14/Q28

Which statement explains why the experiment will **not** succeed?

- A The light waves from the sources are not coherent.
- B The light waves from the sources do not have the same amplitude.
- C The light waves from the sources have a range of wavelengths.
- D The light waves from the sources are not monochromatic.

- 106 A stationary wave is set up on a stretched string, as shown. 9702/13/M/J/14/Q29

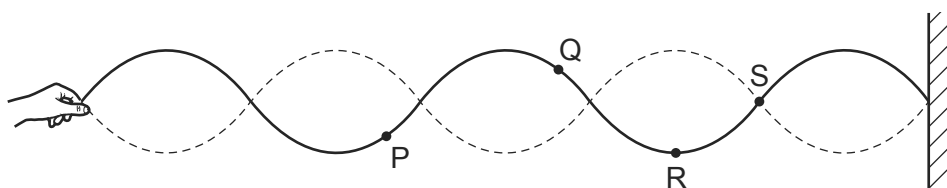

Which statement about the points on the string is correct?

- A Point Q vibrates with the largest amplitude.
  - B Points P and R vibrate in phase.
  - C Point S is an antinode.
  - D The horizontal distance between R and S is half the wavelength.
- 107 Monochromatic light is incident on a diffraction grating and a diffraction pattern is observed.

Which line of the table gives the effect of replacing the grating with one that has more lines per metre?

9702/13/M/J/14/Q30

	number of orders of diffraction visible	angle between first and second orders of diffraction
A	decreases	decreases
B	decreases	increases
C	increases	decreases
D	increases	increases

- 108 A parallel beam of white light passes through a diffraction grating. Orange light of wavelength 600 nm in the fourth order diffraction maximum coincides with blue light in the fifth order diffraction maximum.

9702/11/M/J/14/Q26

What is the wavelength of the blue light?

- A 450 nm
- B 480 nm
- C 500 nm
- D 750 nm

- 109 The principle of superposition states that a certain quantity is added when two or more waves meet at a point.

9702/12/M/J/14/Q25

What is this quantity?

- A** amplitude  
**B** displacement  
**C** intensity  
**D** wavelength
- 110 Light passes through a diffraction grating ruled at 1000 lines per cm and the same wavelength of light also passes through two narrow slits 0.5 mm apart. Both situations produce intensity maxima and minima on a screen.

9702/12/M/J/14/Q26

Which statement about the separation of the maxima on the screen and the sharpness of the maxima is correct?

- A** The diffraction grating maxima are less widely spaced and are less sharp than the two-slit maxima.  
**B** The diffraction grating maxima are less widely spaced and are sharper than the two-slit maxima.  
**C** The diffraction grating maxima are more widely spaced and are less sharp than the two-slit maxima.  
**D** The diffraction grating maxima are more widely spaced and are sharper than the two-slit maxima.
- 111 A stationary wave on a stretched string is set up between two points P and T.

9702/11/M/J/14/Q25

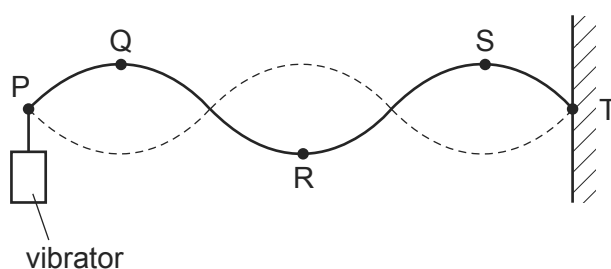

Which statement about the wave is correct?

- A** Point R is at a node.  
**B** Points Q and S vibrate in phase.  
**C** The distance between P and T is three wavelengths.  
**D** The wave shown has the lowest possible frequency.

- 112 The diagram shows an experiment which has been set up to demonstrate two-source interference. Microwaves of wavelength  $\lambda$  pass through two slits  $S_1$  and  $S_2$ .

9702/12/M/J/14/Q27

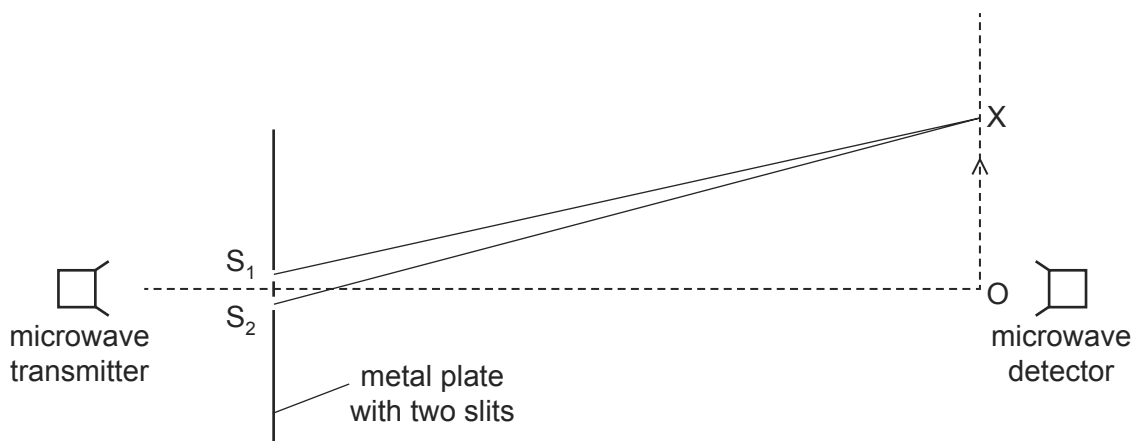

The detector is moved from point O in the direction of the arrow. The signal detected decreases until the detector reaches point X, and then starts to increase again as the detector moves beyond X.

Which equation correctly determines the position of X?

- A**  $OX = \lambda$
- B**  $OX = \lambda/2$
- C**  $S_2X - S_1X = \lambda$
- D**  $S_2X - S_1X = \lambda/2$
- 113 The basic principle of note production in a horn is to set up a stationary wave in an air column.

9702/11/M/J/14/Q27

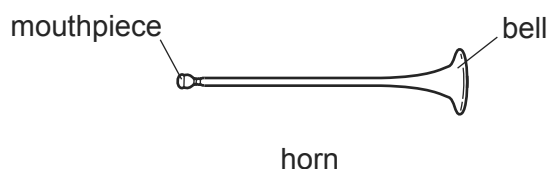

For any note produced by the horn, a node is formed at the mouthpiece and an antinode is formed at the bell. The frequency of the lowest note is 75 Hz.

What are the frequencies of the next two higher notes for this air column?

	first higher note /Hz	second higher note /Hz
<b>A</b>	113	150
<b>B</b>	150	225
<b>C</b>	150	300
<b>D</b>	225	375

114 A stationary sound wave is produced in a tube.

9702/11/O/N/14/Q25

Which statement describes the wave speed?

- A** It is the distance between two adjacent nodes divided by the period of the wave.
- B** It is the speed at which energy is transferred from one antinode to an adjacent antinode.
- C** It is the speed of a particle at an antinode.
- D** It is the speed of one of the progressive waves that are producing the stationary wave.

115 Two identical loudspeakers are connected in series to an a.c. supply, as shown.

9702/11/O/N/14/Q26

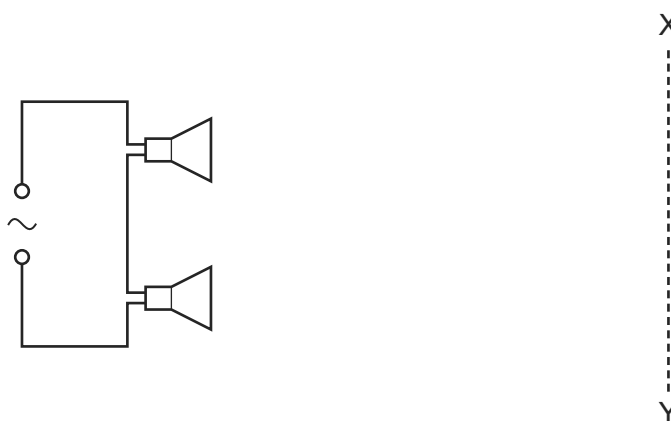

Which graph best shows the variation of the intensity of the sound with distance along the line XY?

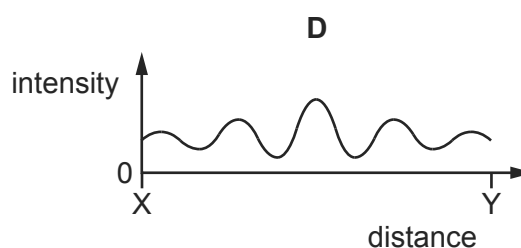
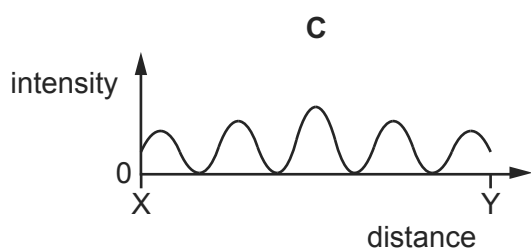
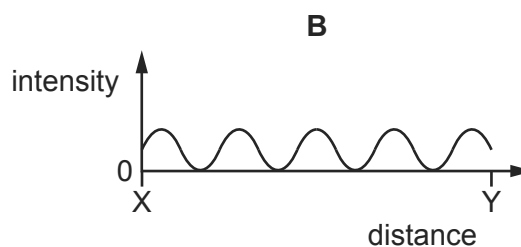
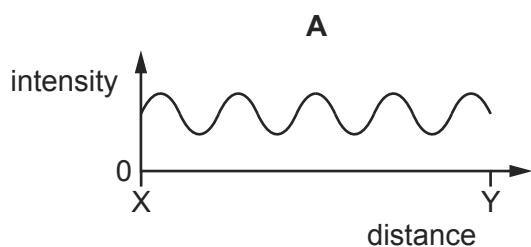

116 Interference fringes are produced on a screen by double-slit interference using light of wavelength 600 nm. The fringe separation is 4.0 mm and the separation of the slits is 0.60 mm.

9702/13/O/N/14/Q30

What is the distance between the double slit and the screen?

- A** 0.25 m
- B** 0.40 m
- C** 2.5 m
- D** 4.0 m

- 117 A diffraction grating experiment is set up using yellow light of wavelength 600 nm. The grating has a slit separation of  $2.00 \mu\text{m}$ .

9702/11/O/N/14/Q27

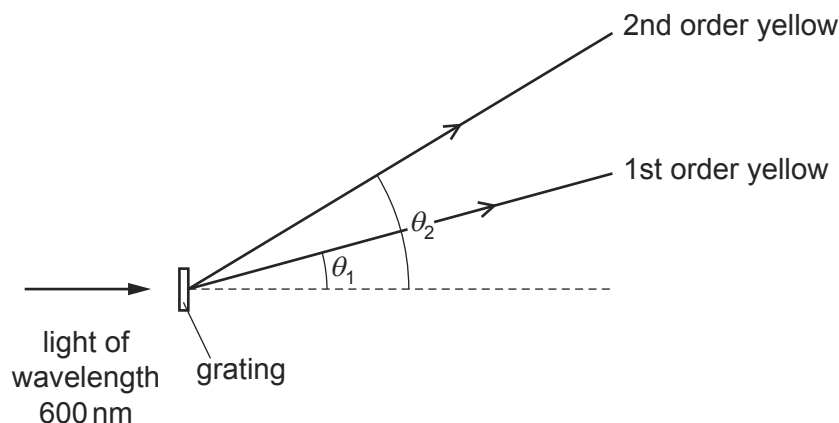

What is the angular separation ( $\theta_2 - \theta_1$ ) between the first and second order maxima of the yellow light?

- A**  $17.5^\circ$       **B**  $19.4^\circ$       **C**  $36.9^\circ$       **D**  $54.3^\circ$
- 118 The variation with distance  $x$  of the intensity  $I$  along a stationary sound wave in air is shown by the following graph.

9702/13/O/N/14/Q29

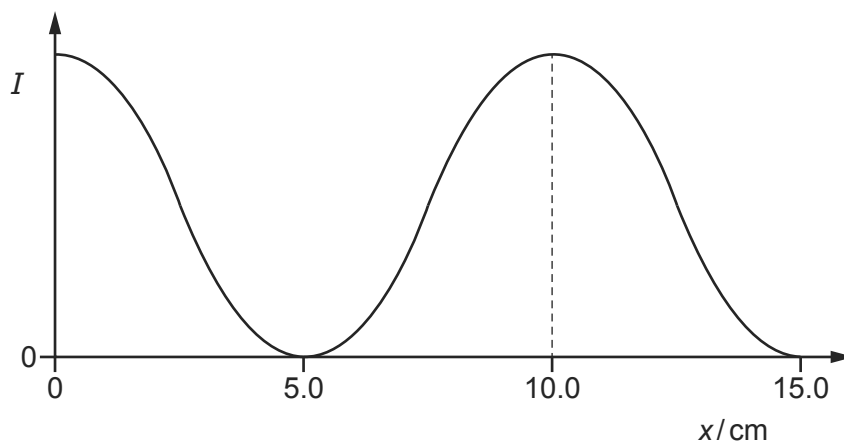

The speed of sound in air is  $340 \text{ m s}^{-1}$ .

What is the frequency of the sound wave?

- A** 1700 Hz      **B** 2270 Hz      **C** 3400 Hz      **D** 6800 Hz
- 119 An organ pipe of length  $l$  is open at both ends. Notes are produced by the pipe when stationary waves are set up.

9702/13/O/N/14/Q29

The speed of sound in the air column is  $v$ .

What is the lowest (fundamental) frequency of the note produced by the pipe?

- A**  $\frac{2v}{l}$       **B**  $\frac{v}{l}$       **C**  $\frac{v}{2l}$       **D**  $\frac{v}{4l}$

120 The table contains statements about stationary and progressive waves.

9702/13/M/J/15/Q27

Which row is correct?

	stationary wave	progressive wave
<b>A</b>	all particles vibrate with the same amplitude	all particles vibrate with the same amplitude
<b>B</b>	energy is transferred along the wave	energy is transferred along the wave
<b>C</b>	particles in adjacent loops vibrate in antiphase	particles vibrate in phase with their immediate neighbours
<b>D</b>	particles one wavelength apart vibrate in phase	particles one wavelength apart vibrate in phase

121 Wave generators at points X and Y produce water waves of the same wavelength. At point Z, the waves from X have the same amplitude as the waves from Y. Distances XZ and YZ are as shown.

9702/13/M/J/15/Q29

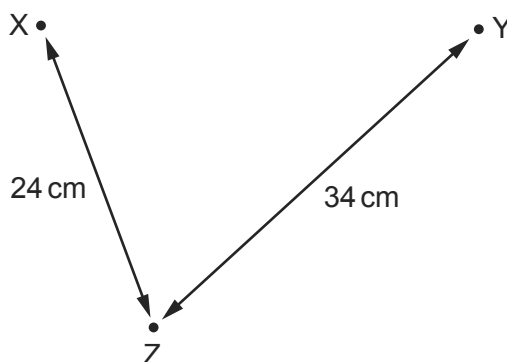

When the wave generators operate in phase, the amplitude of oscillation at Z is zero.

What could be the wavelength of the waves?

- A** 2 cm      **B** 3 cm      **C** 4 cm      **D** 6 cm

122 What is **not** an **essential** condition for an observable interference pattern to occur between the waves from two sources?

9702/12/M/J/15/Q26

- A** The frequencies of the two sources must be equal.  
**B** The sources must be coherent.  
**C** The sources must emit waves of equal amplitude.  
**D** The waves from the two sources must overlap.

- 123 A pattern of waves was observed without being able to view the source of the waves. The pattern is represented in the diagram.

9702/12/M/J/15/Q28

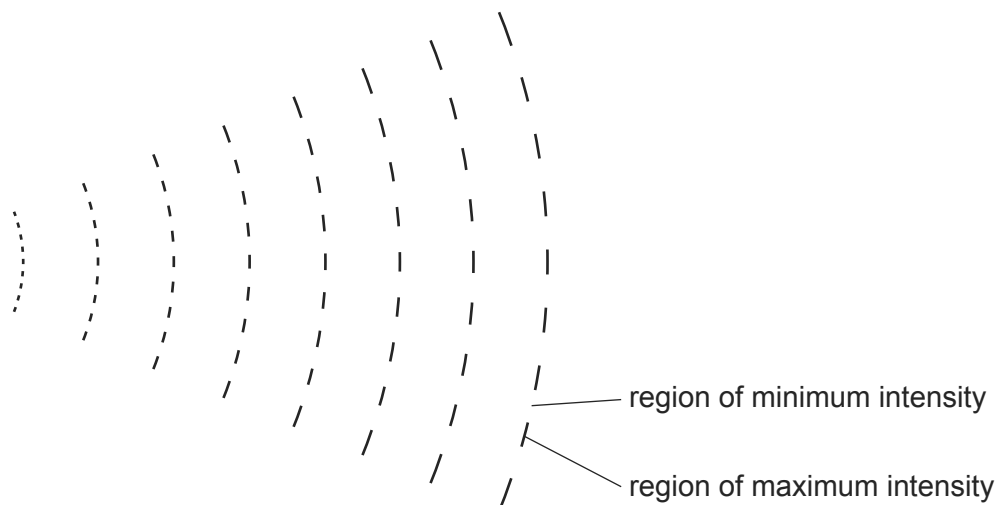

What can cause this pattern?

- A** coherence only  
**B** diffraction and interference  
**C** diffraction only  
**D** interference only
- 124 Source S emits microwaves with a constant amplitude. The microwaves hit a metal screen P and are reflected. A stationary wave is formed between S and P. The wavelength of the microwaves is much smaller than the distance between S and P.

9702/12/M/J/15/Q27

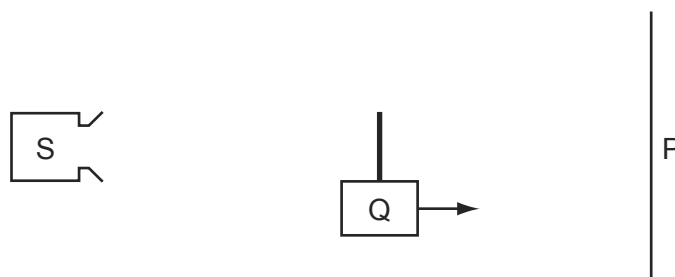

A detector Q is moved at a slow, constant speed from S to P.

What happens to the amplitude of the signal detected by Q?

- A** decreases steadily  
**B** increases and decreases regularly  
**C** increases steadily  
**D** remains constant



- 125 The diagram shows a stationary wave on a string at two instants of maximum vertical displacement.

9702/11/M/J/15/Q28

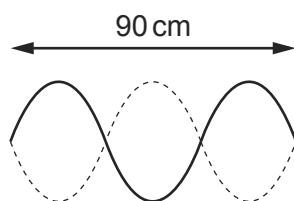

The frequency of the wave is 12 Hz.

What is the speed of the wave?

- A**  $3.6 \text{ ms}^{-1}$       **B**  $7.2 \text{ ms}^{-1}$       **C**  $360 \text{ ms}^{-1}$       **D**  $720 \text{ ms}^{-1}$
- 126 A loudspeaker emitting sound of frequency  $f$  is placed at the open end of a pipe of length  $l$  which is closed at the other end. A standing wave is set up in the pipe.

9702/11/M/J/15/Q29

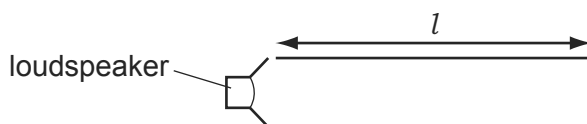

A series of pipes are then set up with either one or two loudspeakers of frequency  $f$ . The pairs of loudspeakers vibrate in phase with each other.

Which pipe contains a standing wave?

- A**
- B**
- C**
- D**

127 In a double-slit experiment the distance between the fringes, on a screen, was too small to measure.

9702/11/M/J/15/Q30

What would increase the distance between the fringes?

- A** increasing the distance between the light source and the slits
- B** increasing the distance between the slits and the screen
- C** increasing the distance between the slits
- D** increasing the frequency of the light source

- 1 Which set of radioactive emissions corresponds to the descriptions given in the table headings?

9702/1/M/J/02/Q38

	high-speed electrons	high-speed helium nuclei	high-frequency photons
<b>A</b>	$\alpha$	$\beta$	$\gamma$
<b>B</b>	$\alpha$	$\gamma$	$\beta$
<b>C</b>	$\beta$	$\alpha$	$\gamma$
<b>D</b>	$\beta$	$\gamma$	$\alpha$

- 2 The nucleus of one of the isotopes of nickel is represented by  ${}^{60}_{28}\text{Ni}$ .

9702/1/M/J/02/Q39

Which line in the table correctly describes a neutral atom of this isotope?

	number of protons	number of neutrons	number of orbital electrons
<b>A</b>	28	32	28
<b>B</b>	28	60	28
<b>C</b>	60	28	28
<b>D</b>	60	32	32

- 3 A nucleus of bohrium  ${}^x_y\text{Bh}$  decays to mendelevium  ${}^{255}_{101}\text{Md}$  by a sequence of three  $\alpha$ -particle emissions.

9702/1/M/J/02/Q40

bohrium  ${}^x_y\text{Bh} \longrightarrow$  dubnium +  $\alpha$

$\longleftarrow$  lawrencium +  $\alpha$

$\longleftarrow$  mendelevium  ${}^{255}_{101}\text{Md}$  +  $\alpha$

How many neutrons are there in a nucleus of  ${}^x_y\text{Bh}$ ?

- A** 267  
**B** 261  
**C** 160  
**D** 154

- 4 The numbers of protons, neutrons and nucleons in three nuclei are shown.

9702/1/O/N/02/Q38

nucleus	number of protons	number of neutrons	number of nucleons
X	15	16	31
Y	15	17	32
Z	16	16	32

Which nuclei are isotopes of the same element?

- A X and Y      B X and Z      C Y and Z      D none of them
- 5 In an experiment to investigate the nature of the atom, a very thin gold film was bombarded with  $\alpha$ -particles. 9702/1/O/N/02/Q39

What pattern of deflection of the  $\alpha$ -particles was observed?

- A A few  $\alpha$ -particles were deflected through angles greater than a right angle.  
 B All  $\alpha$ -particles were deflected from their original path.  
 C Most  $\alpha$ -particles were deflected through angles greater than a right angle.  
 D No  $\alpha$ -particle was deflected through an angle greater than a right angle.
- 6 When a nucleus of  ${}^{238}_{92}\text{U}$  absorbs a slow neutron it subsequently emits two  $\beta$ -particles. 9702/1/O/N/02/Q40

What is the resulting nucleus?

- A  ${}^{240}_{93}\text{Np}$       B  ${}^{240}_{91}\text{Pa}$       C  ${}^{239}_{94}\text{Pu}$       D  ${}^{239}_{90}\text{Th}$
- 7 In what way do the atoms of the isotopes  ${}^{12}_6\text{C}$ ,  ${}^{13}_6\text{C}$  and  ${}^{14}_6\text{C}$  differ? 9702/01/M/J/03/Q38
- A different charge  
 B different numbers of electrons  
 C different numbers of neutrons  
 D different numbers of protons

- 8 A nickel nucleus  ${}^{59}_{28}\text{Ni}$  can be transformed by a process termed K-capture. In this process the nucleus absorbs an orbital electron. 9702/01/O/N/03/Q40

If no other process is involved, what is the resulting nucleus?

- A  ${}^{58}_{28}\text{Ni}$       B  ${}^{58}_{27}\text{Co}$       C  ${}^{59}_{27}\text{Co}$       D  ${}^{59}_{29}\text{Cu}$

- 9 Strontium-90 ( $^{90}_{38}\text{Sr}$ ) is radioactive and emits  $\beta$ -particles.

9702/01/M/J/03/Q39

Which equation could represent this nuclear decay?

- A**  $^{90}_{38}\text{Sr} \rightarrow ^{90}_{39}\text{Sr} + ^0_{-1}\beta$   
**B**  $^{90}_{38}\text{Sr} \rightarrow ^{90}_{39}\text{Y} + ^0_{-1}\beta$   
**C**  $^{90}_{38}\text{Sr} \rightarrow ^{90}_{37}\text{Rb} + ^0_{+1}\beta$   
**D**  $^{90}_{38}\text{Sr} \rightarrow ^{90}_{37}\text{Sr} + ^0_{+1}\beta$

- 10 Protons and neutrons are thought to consist of smaller particles called quarks.

9702/01/M/J/03/Q40

The 'up' quark has a charge of  $\frac{2}{3}e$  : a 'down' quark has a charge of  $-\frac{1}{3}e$ , where  $e$  is the elementary charge ( $+1.6 \times 10^{-19}\text{C}$ ).

How many up quarks and down quarks must a proton contain?

	up quarks	down quarks
<b>A</b>	0	3
<b>B</b>	1	1
<b>C</b>	1	2
<b>D</b>	2	1

- 11 Which are the correct descriptions of a  $\gamma$ -ray and a  $\beta$ -particle?

9702/01/O/N/03/Q38

	$\gamma$ -ray	$\beta$ -particle
<b>A</b>	high-speed electron	electromagnetic radiation
<b>B</b>	electromagnetic radiation	Helium-4 nucleus
<b>C</b>	electromagnetic radiation	high-speed electron
<b>D</b>	high-speed electron	Helium-4 nucleus

- 12 A certain nuclide, Uranium-235, has nucleon number 235, proton number 92 and neutron number 143. Data on four other nuclides are given below.

9702/01/O/N/03/Q39

Which is an isotope of Uranium-235?

	nucleon number	proton number	neutron number
<b>A</b>	235	91	144
<b>B</b>	236	92	144
<b>C</b>	237	94	143
<b>D</b>	238	95	143

- 13 A nucleus of the nuclide  ${}^{241}_{94}\text{Pu}$  decays by emission of a  $\beta$ -particle followed by the emission of an  $\alpha$ -particle. 9702/01/M/J/04/Q38

Which of the nuclides shown is formed?

- A**  ${}^{239}_{93}\text{Np}$       **B**  ${}^{239}_{91}\text{Pa}$       **C**  ${}^{237}_{93}\text{Np}$       **D**  ${}^{237}_{92}\text{U}$

- 14 A thin gold foil is bombarded with  $\alpha$ -particles as shown. 9702/01/M/J/04/Q39

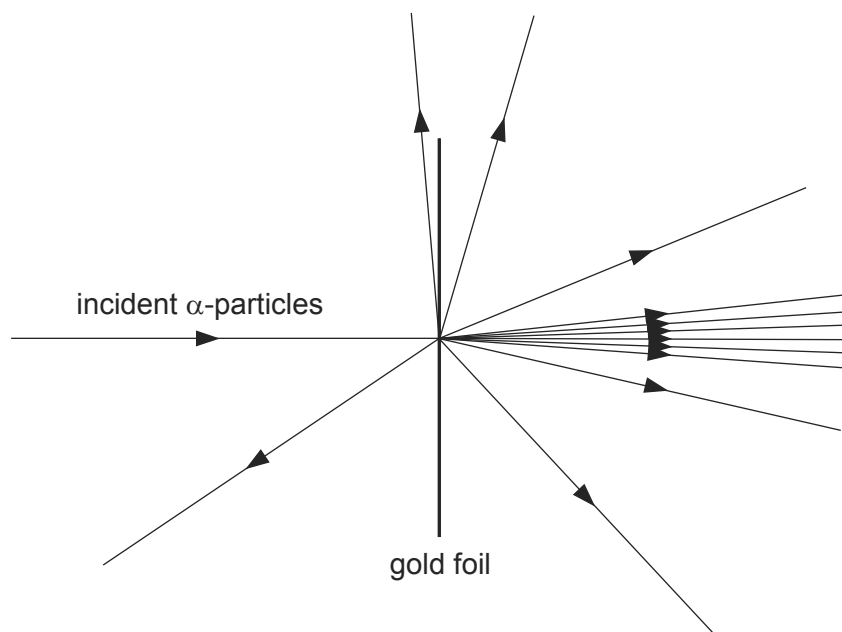

The results of this experiment provide information about the

- A** binding energy of a gold nucleus.  
**B** energy levels of electrons in gold atoms.  
**C** size of a gold nucleus.  
**D** structure of a gold nucleus.
- 15 Isotopes of a given element all have the same 9702/01/M/J/04/Q40
- A** charge/mass ratio.  
**B** neutron number.  
**C** nucleon number.  
**D** proton number.
- 16 What is a correct order of magnitude estimate for the diameter of a typical atomic nucleus? 9702/01/M/J/06/Q38
- A**  $10^{-14}\text{ m}$       **B**  $10^{-18}\text{ m}$       **C**  $10^{-22}\text{ m}$       **D**  $10^{-26}\text{ m}$

- 17 The symbol  ${}_{32}^{77}\text{Ge}$  represents a nuclide of germanium that decays to a nuclide of arsenic (As) by emitting a  $\beta$ -particle.

9702/01/O/N/04/Q38

What is the symbol of this arsenic nuclide?

- A**  ${}_{32}^{76}\text{As}$       **B**  ${}_{32}^{78}\text{As}$       **C**  ${}_{31}^{78}\text{As}$       **D**  ${}_{33}^{77}\text{As}$

- 18 The table shows three properties of different types of ionising radiation.

9702/01/O/N/04/Q39

	<b>X</b>	<b>Y</b>	<b>Z</b>
charge	0	$-1e$	$+2e$
mass	0	$\frac{1}{1840}u$	$4u$
speed	$c$	$\sim 0.9c$	$\sim 0.1c$

What are the radiations **X**, **Y** and **Z**?

	<b>X</b>	<b>Y</b>	<b>Z</b>
<b>A</b>	alpha	beta	X-rays
<b>B</b>	gamma	alpha	beta
<b>C</b>	gamma	beta	alpha
<b>D</b>	X-rays	alpha	beta

- 19 Which conclusion can be drawn from the results of the experiment showing the scattering of  $\alpha$ -particles by gold foil?

9702/01/O/N/04/Q40

- A** Electrons orbit the atomic nucleus in well-defined paths.  
**B** Nuclei of different isotopes contain different numbers of neutrons.  
**C** The atomic nucleus contains protons and neutrons.  
**D** The nucleus is very small compared with the size of the atom.

- 20 Which two nuclei contain the same number of neutrons?

9702/01/M/J/05/Q38

- A**  ${}_{6}^{12}\text{C}$  and  ${}_{6}^{14}\text{C}$   
**B**  ${}_{7}^{16}\text{N}$  and  ${}_{8}^{15}\text{O}$   
**C**  ${}_{11}^{23}\text{Na}$  and  ${}_{12}^{24}\text{Mg}$   
**D**  ${}_{14}^{32}\text{Si}$  and  ${}_{15}^{32}\text{P}$

- 21 A student conducts an experiment using an  $\alpha$ -particle source.

9702/01/M/J/05/Q39

When considering safety precautions, what can be assumed to be the maximum range of  $\alpha$ -particles in air?

- A** between 0 and 5 mm  
**B** between 5 mm and 200 mm  
**C** between 200 mm and 500 mm  
**D** between 500 mm and 1000 mm
- 22 The following represents a sequence of radioactive decays involving two  $\alpha$ -particles and one  $\beta$ -particle.

9702/01/M/J/05/Q40

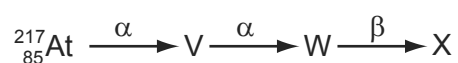

What is the nuclide X?

- A**  ${}_{85}^{213}\text{At}$       **B**  ${}_{77}^{215}\text{Ir}$       **C**  ${}_{82}^{209}\text{Pb}$       **D**  ${}_{81}^{217}\text{Tl}$
- 23 An atomic nucleus emits a  $\beta$ -particle.

9702/01/O/N/05/Q38

What change does this cause to the proton and nucleon numbers of the nucleus?

	proton number	nucleon number
<b>A</b>	-1	+1
<b>B</b>	0	-1
<b>C</b>	+1	-1
<b>D</b>	+1	0

- 24 A nuclear reaction is represented by the equation

9702/01/O/N/05/Q40

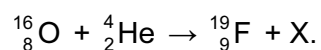

What is particle X?

- A** an  $\alpha$ -particle  
**B** a  $\beta$ -particle  
**C** a neutron  
**D** a proton



- 25 Two  $\alpha$ -particles with equal energies are fired towards the nucleus of a gold atom. 9702/01/O/N/05/Q39

Which diagram best represents their paths?

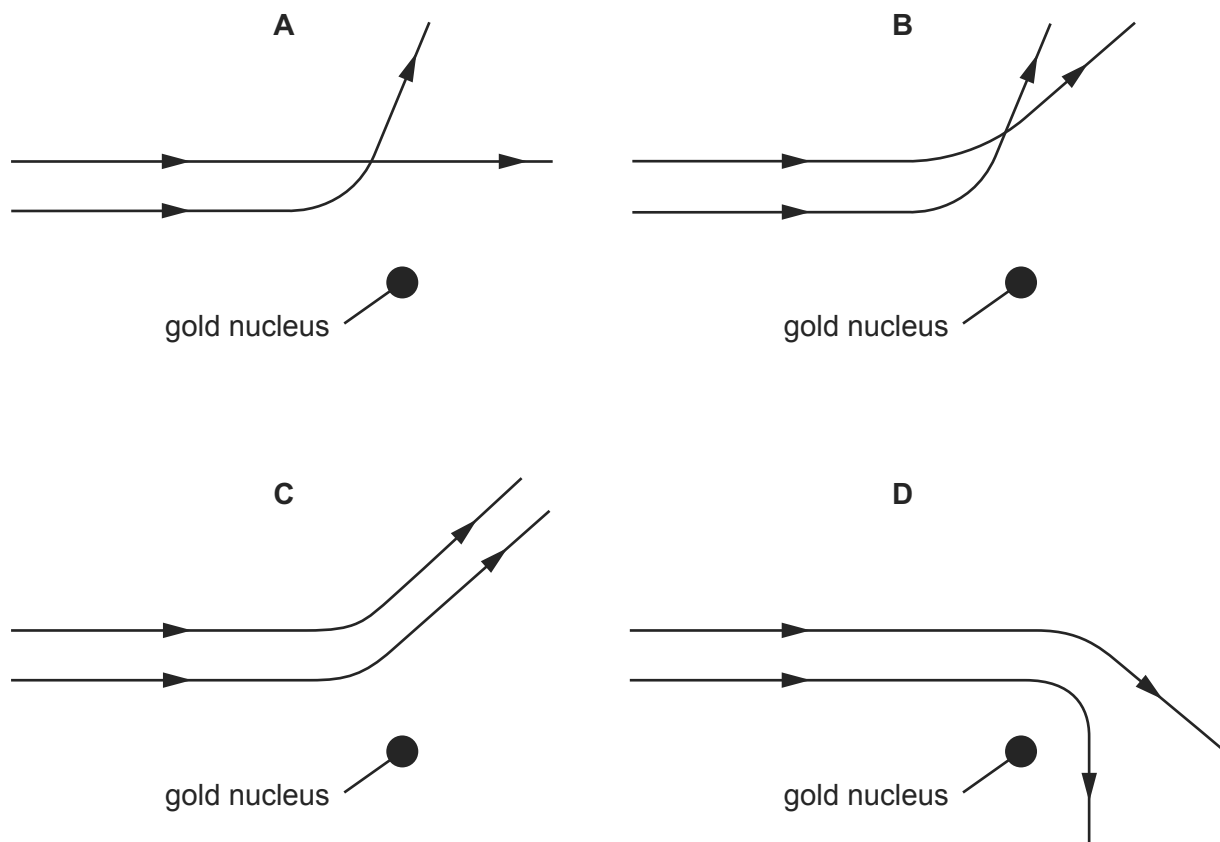

- 26 The decay of a nucleus of neptunium is accompanied by the emission of a  $\beta$ -particle and  $\gamma$ -radiation. 9702/01/M/J/06/Q39

What effect (if any) does this decay have on the proton number and the nucleon number of the nucleus?

	proton number	nucleon number
<b>A</b>	increases	decreases
<b>B</b>	decreases	increases
<b>C</b>	unchanged	decreases
<b>D</b>	increases	unchanged

- 27 The symbol  ${}_{32}^{77}\text{Ge}$  represents a nucleus of germanium that decays to a nucleus of arsenic by emitting a  $\beta$ -particle. 9702/01/M/J/07/Q39

What is the symbol of this arsenic nucleus?

- A**  ${}_{32}^{76}\text{As}$       **B**  ${}_{32}^{78}\text{As}$       **C**  ${}_{31}^{78}\text{As}$       **D**  ${}_{33}^{77}\text{As}$

- 28 Radon-220 is radioactive and decays to Polonium-216 with the emission of an  $\alpha$ -particle. The equation for the radioactive decay is shown. 9702/01/M/J/06/Q40

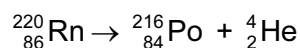

How many neutrons are in the radon and polonium nuclei?

	Rn	Po
<b>A</b>	86	84
<b>B</b>	134	132
<b>C</b>	220	212
<b>D</b>	220	216

- 29 Which statement concerning  $\alpha$ -particles is correct? 9702/01/O/N/06/Q38

- A** An  $\alpha$ -particle has charge  $+4e$ .  
**B** An  $\alpha$ -particle is a helium atom.  
**C** When  $\alpha$ -particles travel through air, they cause ionisation.  
**D** When  $\alpha$ -particles travel through a sheet of gold foil, they make the gold radioactive.

- 30 Where are electrons, neutrons and protons found in an atom? 9702/01/O/N/06/Q39

	electrons	neutrons	protons
<b>A</b>	in the nucleus	in the nucleus	orbiting the nucleus
<b>B</b>	in the nucleus	orbiting the nucleus	in the nucleus
<b>C</b>	orbiting the nucleus	in the nucleus	orbiting the nucleus
<b>D</b>	orbiting the nucleus	in the nucleus	in the nucleus

- 31 Radon  ${}_{86}^{222}\text{Rn}$  decays by  $\alpha$ - and  $\beta$ -emission to bismuth  ${}_{83}^{214}\text{Bi}$ . 9702/01/O/N/06/Q40

For the decay of each nucleus of radon, how many  $\alpha$ - and  $\beta$ -particles are emitted?

	$\alpha$ -particles	$\beta$ -particles
<b>A</b>	1	1
<b>B</b>	2	1
<b>C</b>	1	2
<b>D</b>	2	2

- 32 A detector is exposed to a radioactive source. Fluctuations in the count-rate are observed.

9702/01/M/J/07/Q38

What do these fluctuations indicate about radioactive decay?

- A It is random.
- B It is spontaneous.
- C It is exponential.
- D It is non-linear.

- 33 Each of the nuclei below is accelerated from rest through the same potential difference.

9702/01/M/J/07/Q40

Which one completes the acceleration with the **lowest** speed?

- A  ${}^1_1\text{H}$                       B  ${}^4_2\text{He}$                       C  ${}^7_3\text{Li}$                       D  ${}^9_4\text{Be}$

- 34 How is it possible to distinguish between the isotopes of uranium?

9702/01/O/N/07/Q36

- A Their nuclei have different charge and different mass, and they emit different particles when they decay.
- B Their nuclei have different charge but the same mass.
- C Their nuclei have the same charge but different mass.
- D Their nuclei have the same charge and mass, but they emit different particles when they decay.

- 35 What is **not** conserved in nuclear processes?

9702/01/O/N/07/Q37

- A energy and mass together
- B nucleon number
- C neutron number
- D charge

- 36 The following particles are each accelerated from rest through the same potential difference.

9702/01/O/N/07/Q40

Which one completes the acceleration with the **greatest** momentum?

- A  $\alpha$ -particle
- B electron
- C neutron
- D proton

37 A thin gold foil is bombarded with  $\alpha$ -particles as shown.

9702/01/O/N/07/Q38

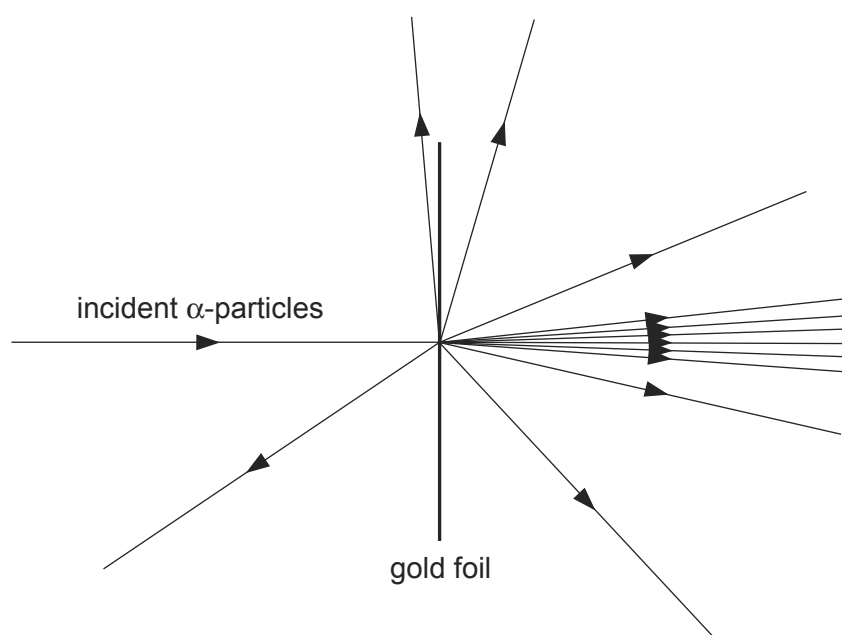

What can be deduced from this experiment?

- A the binding energy of a gold nucleus
  - B the energy levels of electrons in gold atoms
  - C the small size of a gold nucleus
  - D the structure of a gold nucleus
- 38 A radioactive nucleus is formed by  $\beta$ -decay. This nucleus then decays by  $\alpha$ -emission. 9702/01/M/J/08/Q40

Which graph of proton number  $Z$  plotted against nucleon number  $N$  shows the  $\beta$ -decay followed by the  $\alpha$ -emission?

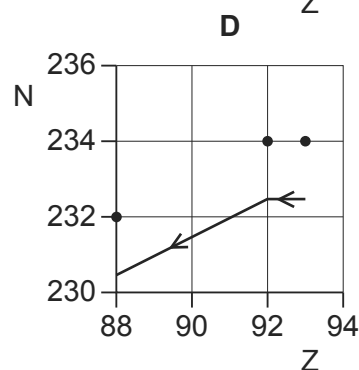
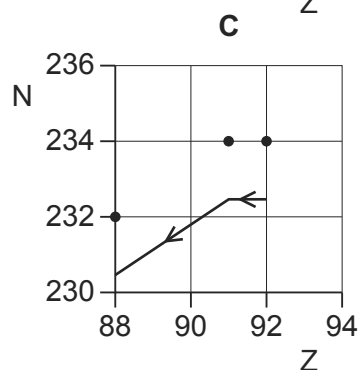
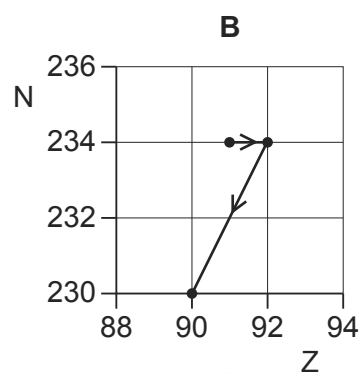
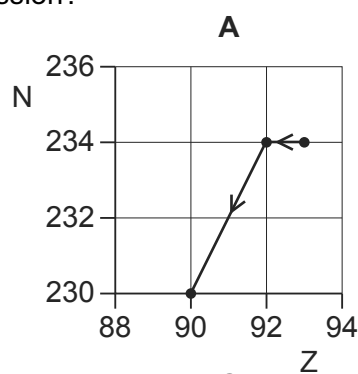

39 What is the approximate mass of a nucleus of uranium?

9702/01/M/J/08/Q39

- A**  $10^{-15}$  kg      **B**  $10^{-20}$  kg      **C**  $10^{-25}$  kg      **D**  $10^{-30}$  kg

40 A zirconium nucleus,  $^{100}_{40}\text{Zr}$ , is a  $\beta$ -emitter. The product nucleus is also a  $\beta$ -emitter. 9702/01/O/N/07/Q39

What is the final resulting nucleus of these two decays?

- A**  $^{100}_{38}\text{Sr}$       **B**  $^{100}_{42}\text{Mo}$       **C**  $^{98}_{40}\text{Zr}$       **D**  $^{102}_{40}\text{Zr}$

41 Which conclusion can be drawn from the results of the experiment showing the scattering of  $\alpha$ -particles by gold foil? 9702/01/O/N/08/Q38

- A** Electrons orbit the atomic nucleus in well-defined paths.  
**B** Nuclei of different isotopes contain different numbers of neutrons.  
**C** The atomic nucleus contains protons and neutrons.  
**D** The nucleus is very small compared with the size of the atom.

42 A nucleus Q has the notation  $^y_x\text{Q}$ .

9702/01/O/N/08/Q39

Which of the following is an isotope of Q?

- A**  $^{y-1}_x\text{Q}$       **B**  $^y_{x-1}\text{Q}$       **C**  $^y_{x+1}\text{Q}$       **D**  $^{y-1}_{x+1}\text{Q}$

43 A  $^{238}_{92}\text{U}$  nucleus decays in two stages to a  $^{234}_{91}\text{Pa}$  nucleus. 9702/01/O/N/08/Q40

What was emitted in these two stages?

- A**  $\alpha + \beta$       **B**  $\alpha + \gamma$       **C**  $\beta + \beta$       **D**  $\beta + \gamma$

44 How do the nucleon (mass) number and proton (atomic) number of two isotopes of an element compare? 9702/01/M/J/09/Q36

	nucleon number	proton number
<b>A</b>	different	different
<b>B</b>	different	same
<b>C</b>	same	different
<b>D</b>	same	same

- 45 Nuclear decay is both spontaneous and random.

9702/01/M/J/09/Q37

When the count rate of a radioactive isotope is measured, the readings fluctuate.

Which row describes what the fluctuations demonstrate?

	spontaneous nature	random nature
<b>A</b>	no	no
<b>B</b>	no	yes
<b>C</b>	yes	no
<b>D</b>	yes	yes

- 46 Which two nuclei contain the same number of neutrons?

9702/01/M/J/09/Q38

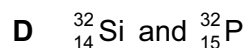
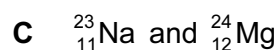
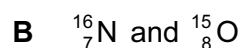
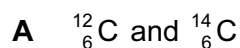

- 47 The calcium nuclide
- $^{42}_{20}\text{Ca}$
- is formed by beta decay.

9702/01/M/J/09/Q39

What are the nucleon (mass) number and proton (atomic) number of the unstable nuclide that underwent beta decay to form the calcium nuclide?

	nucleon number	proton number
<b>A</b>	41	19
<b>B</b>	41	21
<b>C</b>	42	19
<b>D</b>	42	21

- 48 When boron-11 (
- $^{11}_5\text{B}$
- ) is bombarded with
- $\alpha$
- particles, a new nucleus is formed and a neutron is released.

9702/01/M/J/09/Q40

Which nuclear equation could represent this reaction?

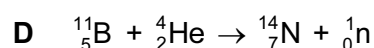
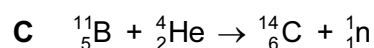
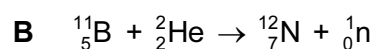
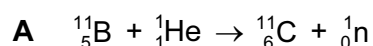

- 49 The gold nucleus  $^{185}_{79}\text{Au}$  undergoes alpha decay.

9702/11/O/N/09/Q37

What are the nucleon (mass) number and proton (atomic) number of the nucleus formed by this decay?

	nucleon number	proton number
<b>A</b>	183	79
<b>B</b>	183	77
<b>C</b>	181	77
<b>D</b>	181	75

- 50 The nuclei of the isotopes of an element all contain the same number of a certain particle.

9702/11/O/N/09/Q38

What is this particle?

- A** electron  
**B** neutron  
**C** nucleon  
**D** proton
- 51 Two  $\alpha$ -particles with equal energies are fired towards the nucleus of a gold atom.

9702/11/O/N/09/Q40

Which diagram best represents their paths?

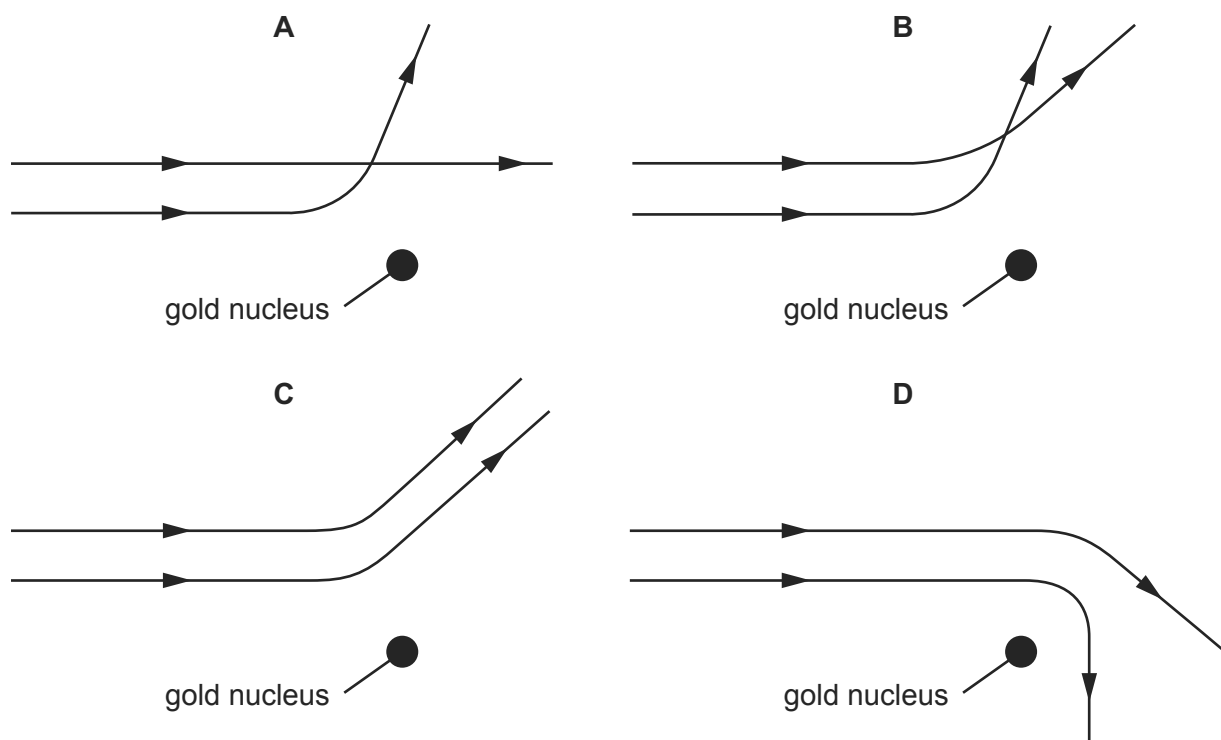

## 52 Alpha, beta and gamma radiations

- 1 are absorbed to different extents in solids,
- 2 behave differently in an electric field,
- 3 behave differently in a magnetic field.

The diagrams illustrate these behaviours.

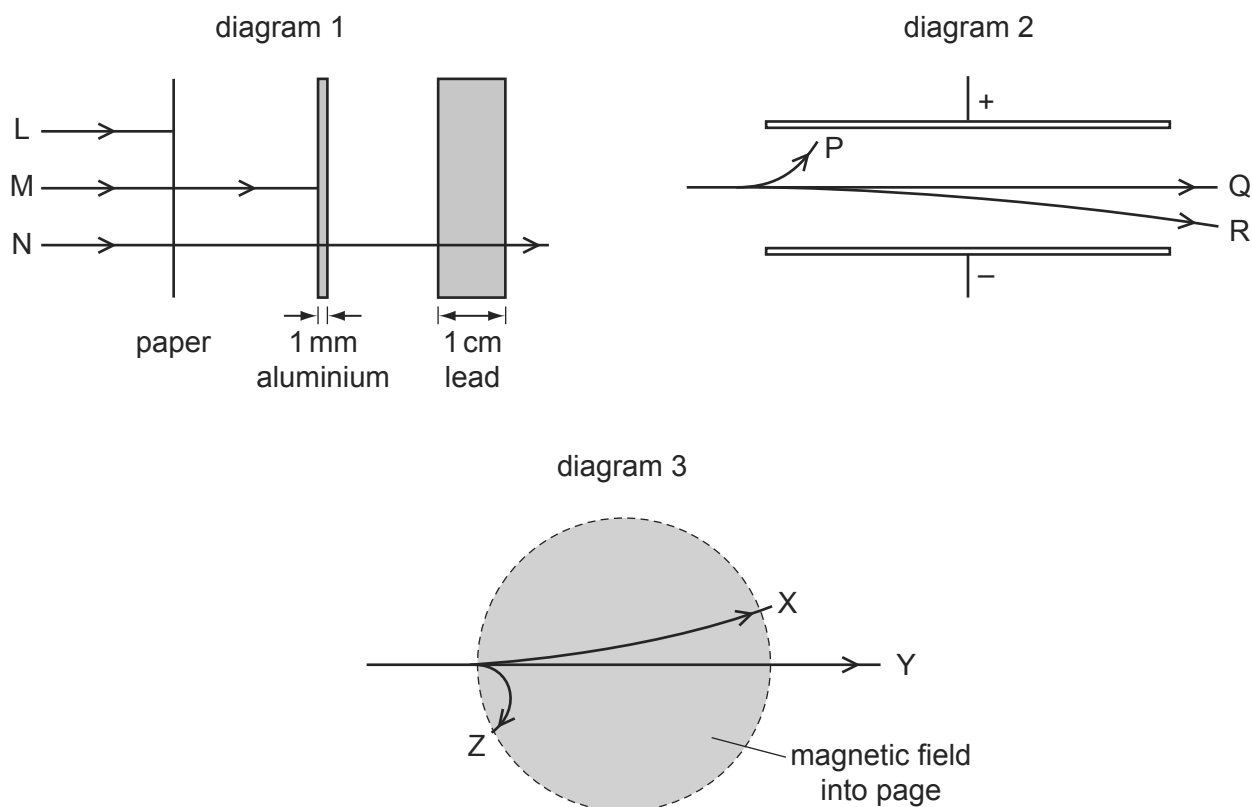

Which three labels on these diagrams refer to the **same** kind of radiation?

- A** L, P, X      **B** L, P, Z      **C** M, P, Z      **D** N, Q, X

53 The gold nucleus  ${}_{79}^{185}\text{Au}$  undergoes alpha decay.

What are the nucleon (mass) number and proton (atomic) number of the nucleus formed by this decay?

	nucleon number	proton number
<b>A</b>	183	79
<b>B</b>	183	77
<b>C</b>	181	77
<b>D</b>	181	75



- 54 The nuclei of the isotopes of an element all contain the same number of a certain particle.

9702/12/O/N/09/Q37

What is this particle?

- A electron
- B neutron
- C nucleon
- D proton

- 55 Alpha, beta and gamma radiations

9702/12/O/N/09/Q38

- 1 are absorbed to different extents in solids,
- 2 behave differently in an electric field,
- 3 behave differently in a magnetic field.

The diagrams illustrate these behaviours.

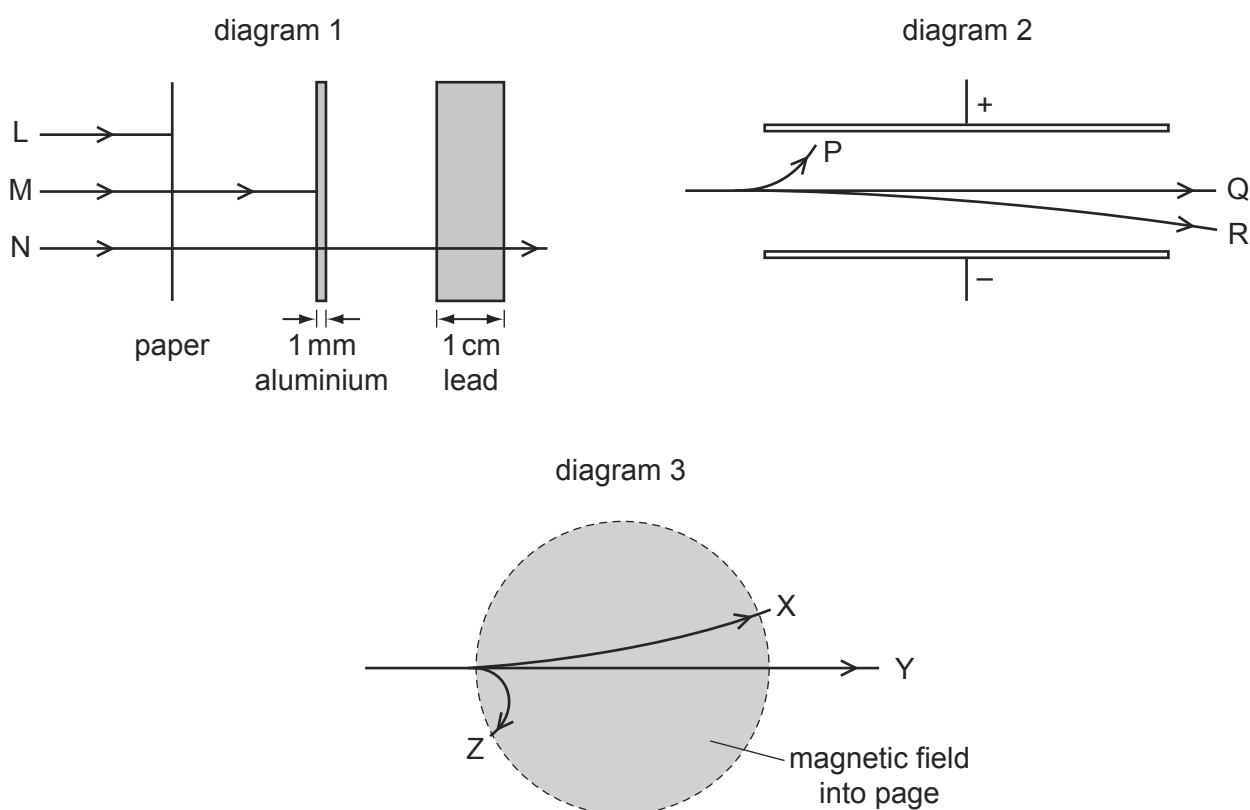

Which three labels on these diagrams refer to the **same** kind of radiation?

- A L, P, X
- B L, P, Z
- C M, P, Z
- D N, Q, X

56 Two  $\alpha$ -particles with equal energies are fired towards the nucleus of a gold atom. 9702/12/O/N/09/Q39

Which diagram best represents their paths?

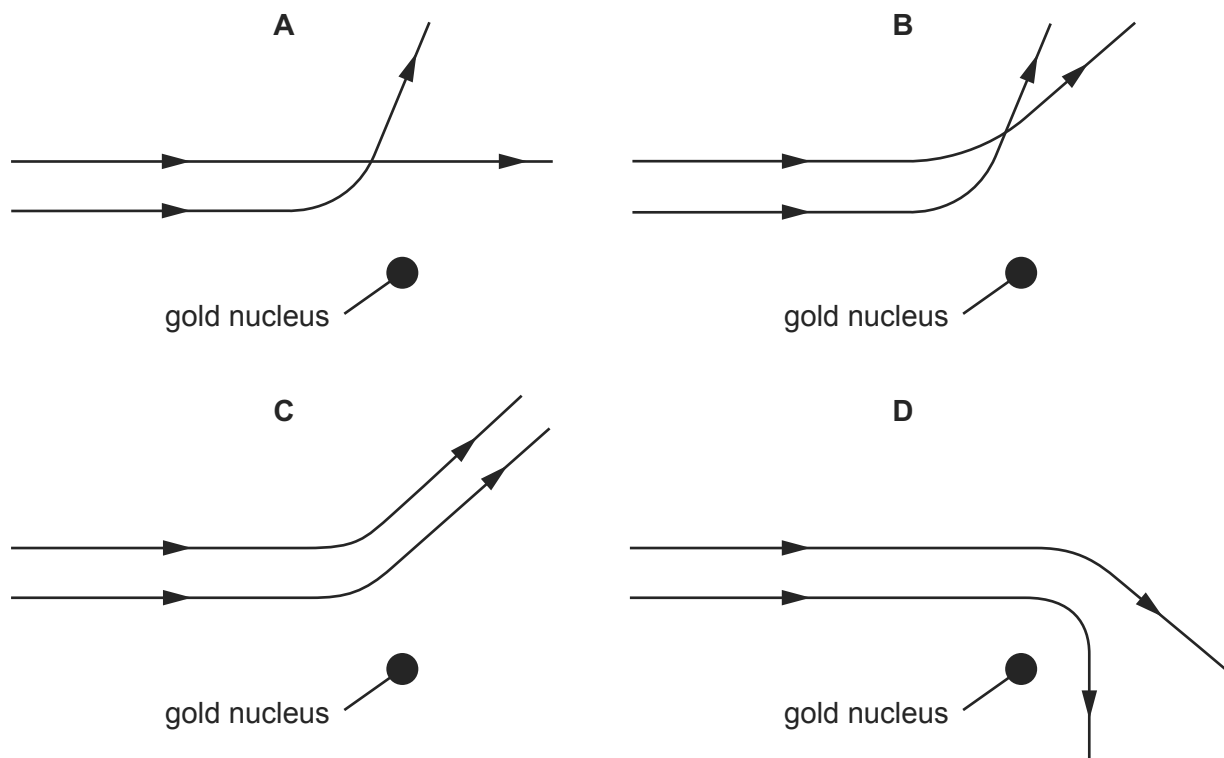

57 What are the correct descriptions of a  $\gamma$ -ray and a  $\beta$ -particle? 9702/11/M/J/10/Q37

	$\gamma$ -ray	$\beta$ -particle
<b>A</b>	high-speed electron	electromagnetic radiation
<b>B</b>	electromagnetic radiation	helium-4 nucleus
<b>C</b>	electromagnetic radiation	high-speed electron
<b>D</b>	high-speed electron	helium-4 nucleus

58 What is **not** conserved in nuclear processes? 9702/11/M/J/10/Q39

- A** charge
- B** momentum
- C** the total number of neutrons
- D** the total number of nucleons

- 59 The grid shows a number of nuclides arranged according to the number of protons and the number of neutrons in each.

9702/11/M/J/10/Q38

A nucleus of the nuclide  ${}^8_3\text{Li}$  decays by emitting a  $\beta$ -particle.

What is the resulting nuclide?

number of protons	4					<b>A</b>	<b>B</b>	
	3				${}^6_3\text{Li}$	${}^7_3\text{Li}$	${}^8_3\text{Li}$	
	2		${}^3_2\text{He}$	${}^4_2\text{He}$			<b>C</b>	<b>D</b>
	1	${}^1_1\text{H}$	${}^2_1\text{H}$					
		0	1	2	3	4	5	6
		number of neutrons						

- 60 The following represents a sequence of radioactive decays involving two  $\alpha$ -particles and one  $\beta$ -particle.

9702/11/M/J/10/Q40

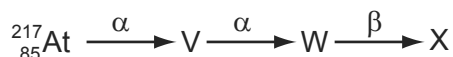

What is the nuclide X?

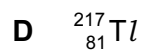
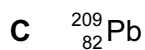
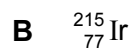
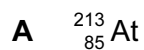

- 61 The grid shows a number of nuclides arranged according to the number of protons and the number of neutrons in each.

9702/12/M/J/10/Q37

A nucleus of the nuclide  ${}^8_3\text{Li}$  decays by emitting a  $\beta$ -particle.

What is the resulting nuclide?

number of protons	4					<b>A</b>	<b>B</b>	
	3				${}^6_3\text{Li}$	${}^7_3\text{Li}$	${}^8_3\text{Li}$	
	2		${}^3_2\text{He}$	${}^4_2\text{He}$			<b>C</b>	<b>D</b>
	1	${}^1_1\text{H}$	${}^2_1\text{H}$					
		0	1	2	3	4	5	6
		number of neutrons						

- 62 The following represents a sequence of radioactive decays involving two  $\alpha$ -particles and one  $\beta$ -particle. 9702/12/M/J/10/Q38

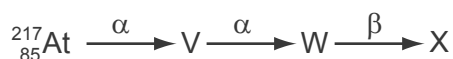

What is the nuclide X?

- A**  ${}_{85}^{213}\text{At}$       **B**  ${}_{77}^{215}\text{Ir}$       **C**  ${}_{82}^{209}\text{Pb}$       **D**  ${}_{81}^{217}\text{Tl}$

- 63 What are the correct descriptions of a  $\gamma$ -ray and a  $\beta$ -particle? 9702/12/M/J/10/Q39

	$\gamma$ -ray	$\beta$ -particle
<b>A</b>	high-speed electron	electromagnetic radiation
<b>B</b>	electromagnetic radiation	helium-4 nucleus
<b>C</b>	electromagnetic radiation	high-speed electron
<b>D</b>	high-speed electron	helium-4 nucleus

- 64 What is **not** conserved in nuclear processes? 9702/12/M/J/10/Q40

- A** charge  
**B** momentum  
**C** the total number of neutrons  
**D** the total number of nucleons

- 65 The grid shows a number of nuclides arranged according to the number of protons and the number of neutrons in each. 9702/13/M/J/10/Q40

A nucleus of the nuclide  ${}^8_3\text{Li}$  decays by emitting a  $\beta$ -particle.

What is the resulting nuclide?

number of protons	4					<b>A</b>	<b>B</b>	
	3			${}^6_3\text{Li}$	${}^7_3\text{Li}$	${}^8_3\text{Li}$		
	2		${}^3_2\text{He}$	${}^4_2\text{He}$			<b>C</b>	<b>D</b>
	1	${}^1_1\text{H}$	${}^2_1\text{H}$					
		0	1	2	3	4	5	6
		number of neutrons						

- 66 The following represents a sequence of radioactive decays involving two  $\alpha$ -particles and one  $\beta$ -particle. 9702/13/M/J/10/Q39

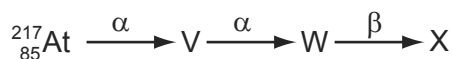

What is the nuclide X?

- A  ${}_{85}^{213}\text{At}$       B  ${}_{77}^{215}\text{Ir}$       C  ${}_{82}^{209}\text{Pb}$       D  ${}_{81}^{217}\text{Tl}$
- 67 What is **not** conserved in nuclear processes? 9702/13/M/J/10/Q37
- A charge  
B momentum  
C the total number of neutrons  
D the total number of nucleons
- 68 What are the correct descriptions of a  $\gamma$ -ray and a  $\beta$ -particle? 9702/13/M/J/10/Q38

	$\gamma$ -ray	$\beta$ -particle
A	high-speed electron	electromagnetic radiation
B	electromagnetic radiation	helium-4 nucleus
C	electromagnetic radiation	high-speed electron
D	high-speed electron	helium-4 nucleus

- 69 When a magnesium nucleus  ${}_{12}^{25}\text{Mg}$  is hit by a gamma ray, a sodium nucleus  ${}_{11}^{24}\text{Na}$  is formed and another particle is emitted.

What are the nucleon number (mass number) and proton number (atomic number) of the other particle produced in this nuclear reaction? 9702/11/O/N/10/Q39

	nucleon number	proton number
A	0	-1
B	0	1
C	1	-1
D	1	1

- 70 Uranium-238,  ${}_{92}^{238}\text{U}$ , decays by  $\alpha$ -emission into a daughter product which in turn decays by  $\beta$ -emission into a grand-daughter product. 9702/13/M/J/11/Q40

What is the grand-daughter product?

- A  ${}_{90}^{234}\text{Th}$       B  ${}_{91}^{234}\text{Pa}$       C  ${}_{92}^{234}\text{U}$       D  ${}_{90}^{230}\text{Th}$

71 Uranium-235 may be represented by the symbol  ${}_{92}^{235}\text{U}$ .

9702/11/O/N/10/Q38

Which row shows the numbers of nucleons, protons and neutrons in a  ${}_{92}^{235}\text{U}$  nucleus?

	nucleons	protons	neutrons
<b>A</b>	92	235	143
<b>B</b>	143	92	235
<b>C</b>	235	92	143
<b>D</b>	235	143	92

72 Which nuclear equation shows the beta decay of a nucleus of argon (Ar) into potassium (K)?

9702/11/O/N/10/Q40

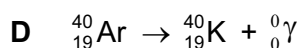
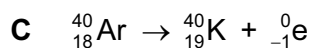
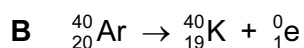
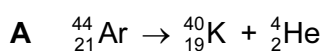

73 A counter recording radioactive decays from a radioactive source gives the following counts in equal intervals of time.

9702/12/O/N/10/Q40

time / min	counts
0–10	424
10–20	395
20–30	413
30–40	363
40–50	366
50–60	294
60–70	301
70–80	253
80–90	212

What can be deduced from these readings?

- A** that radioactivity is random and that the half-life is 90 minutes
- B** that radioactivity is random and that the half-life is uncertain
- C** that radioactivity is spontaneous and that the half-life is 90 minutes
- D** that radioactivity is spontaneous and that the half-life is uncertain

- 74 In the Rutherford scattering experiment,  $\alpha$ -particles were fired at a thin gold foil. A small proportion of the  $\alpha$ -particles were deflected through large angles. 9702/12/O/N/10/Q38

Which statement gives the correct conclusion that could be drawn directly from these results?

- A The atom is made up of electrons, protons and neutrons.
- B The nucleus is at the centre of the atom.
- C The nucleus is made up of protons and neutrons.
- D The atom contains a very small, charged nucleus.

- 75 Which statement about the nuclei of the atoms of an element is correct? 9702/12/O/N/10/Q39

- A Every nucleus of an element contains an equal number of neutrons and protons.
- B Every nucleus of an element contains the same number of neutrons as all others of that element, but the number of protons may differ.
- C Every nucleus of an element contains the same number of protons as all others of that element, but the number of neutrons may differ.
- D The number of protons in a nucleus differs from isotope to isotope of an element, as do the number of neutrons.

- 76 When a magnesium nucleus  ${}_{12}^{25}\text{Mg}$  is hit by a gamma ray, a sodium nucleus  ${}_{11}^{24}\text{Na}$  is formed and another particle is emitted. 9702/13/O/N/10/Q40

What are the nucleon number (mass number) and proton number (atomic number) of the other particle produced in this nuclear reaction?

	nucleon number	proton number
<b>A</b>	0	-1
<b>B</b>	0	1
<b>C</b>	1	-1
<b>D</b>	1	1

- 77 The first artificial radioactive substance was made by bombarding aluminium,  ${}_{13}^{27}\text{Al}$ , with  $\alpha$ -particles. This produced an unstable isotope of phosphorus,  ${}_{15}^{30}\text{P}$ . 9702/11/M/J/11/Q38

What was the by-product of this reaction?

- A an  $\alpha$ -particle
- B a  $\beta$ -particle
- C a  $\gamma$ -ray
- D a neutron

78 Which nuclear equation shows the beta decay of a nucleus of argon (Ar) into potassium (K)?

9702/13/O/N/10/Q38

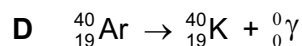
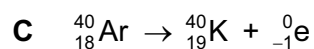
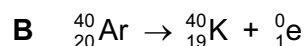
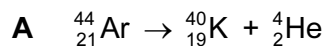

79 Uranium-235 may be represented by the symbol  ${}^{235}_{92}\text{U}$ .

9702/13/O/N/10/Q39

Which row shows the numbers of nucleons, protons and neutrons in a  ${}^{235}_{92}\text{U}$  nucleus?

	nucleons	protons	neutrons
<b>A</b>	92	235	143
<b>B</b>	143	92	235
<b>C</b>	235	92	143
<b>D</b>	235	143	92

80 The uranium nucleus  ${}^{238}_{92}\text{U}$  undergoes  $\alpha$ -decay, producing nucleus X.

9702/12/M/J/11/Q39

Nucleus X undergoes  $\beta$ -decay, producing nucleus Y.

For nucleus Y, what are the values of the proton number and nucleon number?

	proton number	nucleon number
<b>A</b>	89	234
<b>B</b>	89	236
<b>C</b>	91	234
<b>D</b>	91	236

81 Radon-220 is radioactive and decays to polonium-216 with the emission of an  $\alpha$ -particle. The equation for the radioactive decay is shown.

9702/12/M/J/11/Q40

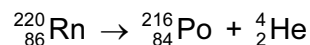

How many neutrons are in the radon and polonium nuclei?

	Rn	Po
<b>A</b>	86	84
<b>B</b>	134	132
<b>C</b>	220	212
<b>D</b>	220	216



- 82 Uranium-238,  ${}^{238}_{92}\text{U}$ , decays by  $\alpha$ -emission into a daughter product which in turn decays by  $\beta$ -emission into a grand-daughter product. 9702/11/M/J/11/Q39

What is the grand-daughter product?

- A**  ${}^{234}_{90}\text{Th}$       **B**  ${}^{234}_{91}\text{Pa}$       **C**  ${}^{234}_{92}\text{U}$       **D**  ${}^{230}_{90}\text{Th}$

- 83 Which statement about nuclei is correct? 9702/11/M/J/11/Q40

- A** Different isotopic nuclei have different proton numbers.  
**B** For some nuclei, the nucleon number can be less than the proton number.  
**C** In some nuclear processes, mass-energy is not conserved.  
**D** Nucleon numbers of nuclei are unchanged by the emission of  $\beta$ -particles.

- 84 Which statement about nuclei is correct? 9702/13/M/J/11/Q38

- A** Different isotopic nuclei have different proton numbers.  
**B** For some nuclei, the nucleon number can be less than the proton number.  
**C** In some nuclear processes, mass-energy is not conserved.  
**D** Nucleon numbers of nuclei are unchanged by the emission of  $\beta$ -particles.

- 85 The first artificial radioactive substance was made by bombarding aluminium,  ${}^{27}_{13}\text{Al}$ , with  $\alpha$ -particles. This produced an unstable isotope of phosphorus,  ${}^{30}_{15}\text{P}$ . 9702/13/M/J/11/Q39

What was the by-product of this reaction?

- A** an  $\alpha$ -particle  
**B** a  $\beta$ -particle  
**C** a  $\gamma$ -ray  
**D** a neutron

- 86 An experiment in which  $\alpha$ -particles were deflected by a gold foil produced new insights into the structure of the atom. 9702/11/M/J/12/Q39

Which conclusion can be drawn from the results of the experiment?

- A** Atomic nuclei occupy a very small fraction of the volume of an atom.  
**B** Electrons orbit the atomic nucleus.  
**C** Some atoms of the same element contain different numbers of neutrons.  
**D** The atomic nucleus contains protons and neutrons.

- 87 The circuit below has a current  $I$  in the resistor R.

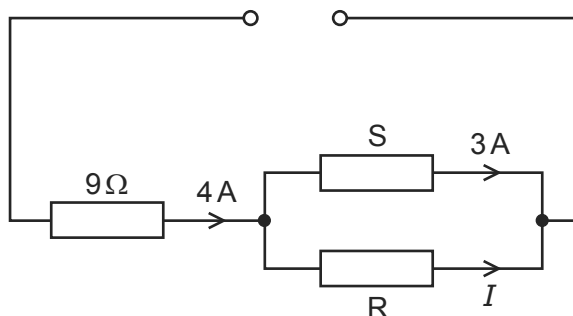

What must be known in order to determine the value of  $I$ ?

- A** e.m.f. of the power supply  
**B** resistance of resistor S  
**C** Kirchhoff's first law  
**D** Kirchhoff's second law
- 88 Which statement concerning  $\alpha$ -particles is correct? 9702/12/O/N/11/Q39

- A** An  $\alpha$ -particle has charge  $+4e$ .  
**B** An  $\alpha$ -particle is a helium atom.  
**C** When  $\alpha$ -particles travel through air, they cause ionisation.  
**D** When  $\alpha$ -particles travel through a sheet of gold foil, they make the gold radioactive.

- 89 A nucleus of the nuclide  ${}^{241}_{94}\text{Pu}$  decays by emission of a  $\beta$ -particle followed by the emission of an  $\alpha$ -particle. 9702/12/O/N/11/Q40

Which nucleus is formed?

- A**  ${}^{239}_{93}\text{Np}$       **B**  ${}^{239}_{91}\text{Pa}$       **C**  ${}^{237}_{93}\text{Np}$       **D**  ${}^{237}_{92}\text{U}$

- 90 Radon  ${}^{222}_{86}\text{Rn}$  is the start of a decay chain that forms bismuth  ${}^{214}_{83}\text{Bi}$  by alpha and beta emission. 9702/12/M/J/12/Q40

For the decay of each nucleus of radon, how many  $\alpha$ -particles and  $\beta$ -particles are emitted?

	$\alpha$ -particles	$\beta$ -particles
<b>A</b>	1	1
<b>B</b>	2	1
<b>C</b>	1	2
<b>D</b>	2	2

- 91 Nuclear decay is both spontaneous and random in nature.

Which row gives the correct experimental evidence for these properties?

	spontaneous nature of decay	random nature of decay
<b>A</b>	the decay rate is not affected by pressure	the decay rate is not affected by temperature
<b>B</b>	the decay rate is not affected by pressure	the rate at which radiation is received at a counter fluctuates
<b>C</b>	the decay rate is not affected by temperature	the decay rate is not affected by pressure
<b>D</b>	the rate at which radiation is received at a counter fluctuates	the decay rate is not affected by pressure

- 92 Thorium-234 ( ${}_{90}^{234}\text{Th}$ ) decays by  $\beta$ -emission into a daughter product which in turn decays by further  $\beta$ -emission into a granddaughter product.

9702/11/M/J/12/Q40

Which letter in the diagram represents the granddaughter product?

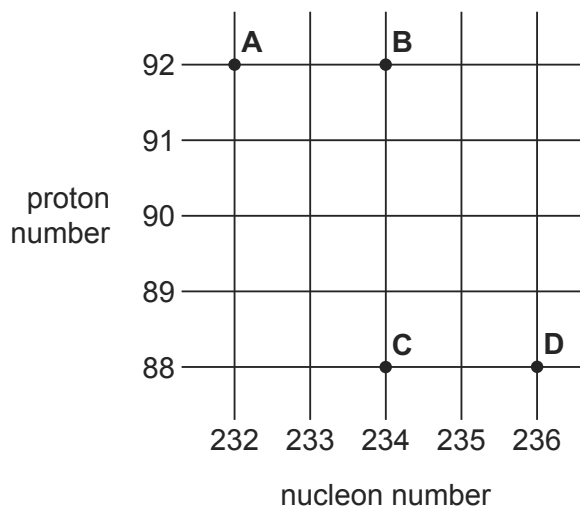

- 93 An experiment in which  $\alpha$ -particles were deflected by a gold foil produced new insights into the structure of the atom.

9702/13/M/J/12/Q40

Which conclusion can be drawn from the results of the experiment?

- A** Atomic nuclei occupy a very small fraction of the volume of an atom.
- B** Electrons orbit the atomic nucleus.
- C** Some atoms of the same element contain different numbers of neutrons.
- D** The atomic nucleus contains protons and neutrons.

- 94 Thorium-234 ( $^{234}_{90}\text{Th}$ ) decays by  $\beta$ -emission into a daughter product which in turn decays by further  $\beta$ -emission into a granddaughter product. 9702/13/M/J/12/Q39

Which letter in the diagram represents the granddaughter product?

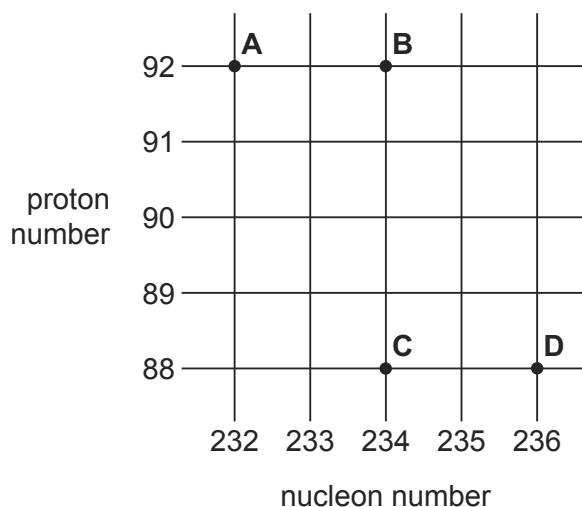

- 95 A material contains a radioactive isotope that disintegrates solely by the emission of  $\alpha$ -particles at a rate of  $100\text{ s}^{-1}$ . 9702/12/O/N/12/Q39

Which statement about this material is correct?

- A The number of atoms in the material diminishes at a rate of  $100\text{ s}^{-1}$ .
  - B The number of neutrons in the material diminishes at a rate of  $100\text{ s}^{-1}$ .
  - C The number of nucleons in the material diminishes at a rate of  $400\text{ s}^{-1}$ .
  - D The number of protons in the material diminishes at a rate of  $100\text{ s}^{-1}$ .
- 96 In a radioactive decay series, three successive decays each result in a particle being emitted.

The first decay results in the emission of a  $\beta$ -particle. The second decay results in the emission of an  $\alpha$ -particle. The third decay results in the emission of another  $\beta$ -particle. 9702/11/O/N/12/Q40

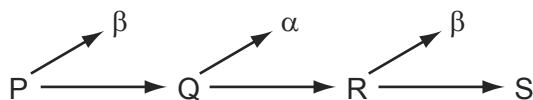

Nuclides P and S are compared.

Which statement is correct?

- A P and S are identical in all respects.
- B P and S are isotopes of the same element.
- C S is a different element of lower atomic number.
- D S is a different element of reduced mass.

- 97 A class of students used dice to simulate radioactive decay. After each throw, those dice showing a '6' were removed. The graph shows the results.

9702/11/O/N/12/Q38

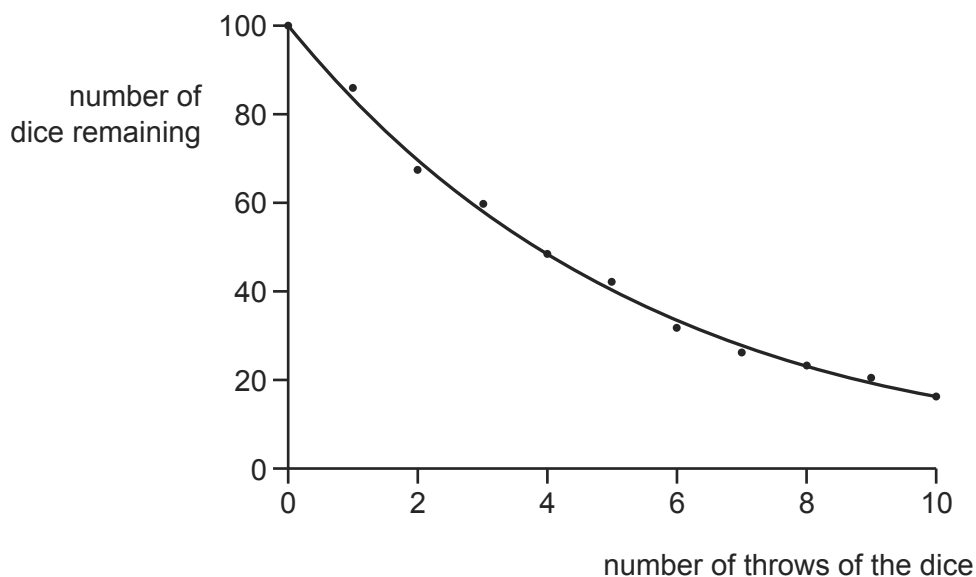

What could the scatter of points about the best-fit curve represent for actual radioactive decay?

- A background count not being taken into account
  - B more than one type of radiation being present
  - C the random nature of radioactive decay
  - D the spontaneous nature of radioactive decay
- 98 Which statement about alpha, beta and gamma radiation is correct?

9702/11/O/N/12/Q39

- A Alpha radiation has the greatest ionising power.
- B Beta radiation has the greatest ionising power.
- C Gamma radiation has the greatest ionising power.
- D Alpha, beta and gamma radiation have nearly equal ionising powers.

- 99 A different nucleus can be formed by bombarding a stable nucleus with an energetic  $\alpha$ -particle.

9702/12/O/N/12/Q40

${}_{11}^{23}\text{Na}$  is bombarded with an energetic  $\alpha$ -particle.

What could be the products of this nuclear reaction?

- A  ${}_{10}^{25}\text{Ne}$  + neutron
- B  ${}_{11}^{25}\text{Na}$  + proton
- C  ${}_{12}^{26}\text{Mg}$  +  $\beta$
- D  ${}_{13}^{27}\text{Al}$  +  $\gamma$

- 100 A nuclear isotope emits radiation which is detected by a Geiger-Müller tube held at a distance of about 10 cm from the radioactive source. The radiation is stopped completely by a 2 mm thick sheet of lead.

9702/13/O/N/12/Q38

What can be deduced from this information about the emission from the isotope?

- A** It could be alpha and beta radiation, but not gamma radiation.  
**B** It could be alpha and gamma radiation, but not beta radiation.  
**C** It could be beta and gamma radiation, but not alpha radiation.  
**D** It could be alpha, beta and gamma radiation.
- 101 What remains constant during  $\beta$ -emission from a number of identical nuclei in a substance?

9702/13/O/N/12/Q39

- A** energy of the  $\beta$ -particles  
**B** neutron number of the nuclei  
**C** nucleon number of the nuclei  
**D** proton number of the nuclei

- 102 The graph of neutron number against proton number represents a sequence of radioactive decays.

9702/13/O/N/12/Q40

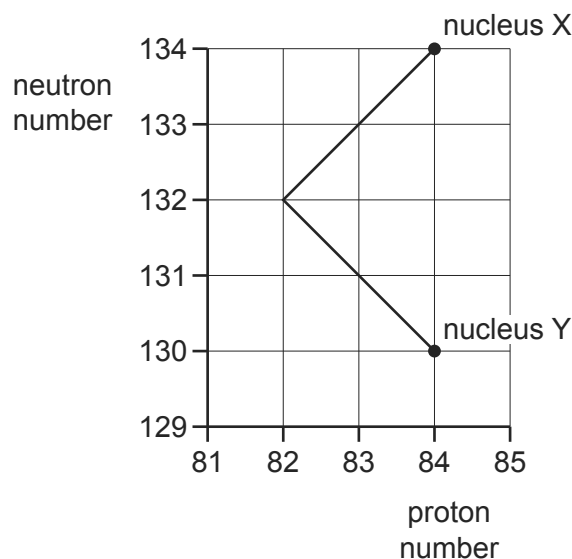

Nucleus X is at the start of the sequence and, after the decays have occurred, nucleus Y is formed.

What is emitted during the sequence of decays?

- A** one  $\alpha$ -particle followed by one  $\beta$ -particle  
**B** one  $\alpha$ -particle followed by two  $\beta$ -particles  
**C** two  $\alpha$ -particles followed by two  $\beta$ -particles  
**D** two  $\beta$ -particles followed by one  $\alpha$ -particle

- 103 A nickel nucleus  ${}_{28}^{59}\text{Ni}$  can be transformed by a process termed K-capture. In this process the nucleus absorbs an orbital electron. 9702/11/M/J/13/Q38

If no other process is involved, what is the resulting nucleus?

- A**  ${}_{28}^{58}\text{Ni}$       **B**  ${}_{27}^{58}\text{Co}$       **C**  ${}_{27}^{59}\text{Co}$       **D**  ${}_{29}^{59}\text{Cu}$

- 104 It was once thought that the mass of an atom is spread uniformly through the volume of the atom. When  $\alpha$ -particles are directed at a piece of gold foil, the results led scientists to believe instead that nearly all the mass of the gold atom is concentrated at a point inside the atom. 9702/11/M/J/13/Q39

Which effect is possible **only** if nearly all the mass of the gold atom is concentrated at a point?

- A** a few  $\alpha$ -particles bounce back  
**B** most  $\alpha$ -particles are only slightly deflected  
**C** some  $\alpha$ -particles pass through without any deflection  
**D** some  $\alpha$ -particles are absorbed

- 105 Which pair of nuclei are isotopes of one another? 9702/11/M/J/13/Q40

	nucleon number	number of neutrons
<b>A</b>	186	112
	180	118
<b>B</b>	186	112
	182	108
<b>C</b>	184	110
	187	110
<b>D</b>	186	110
	186	112

- 106 An actinium nucleus has a nucleon number of 227 and a proton number of 89. It decays to form a radium nucleus, emitting a beta particle and an alpha particle in the process. 9702/12/M/J/13/Q40

What are the nucleon number and the proton number of this radium nucleus?

	nucleon number	proton number
<b>A</b>	223	87
<b>B</b>	223	88
<b>C</b>	224	87
<b>D</b>	225	86

107 What is the approximate mass of an alpha particle?

9702/12/M/J/13/Q39

- A  $10^{-28}$  kg
- B  $10^{-26}$  kg
- C  $10^{-24}$  kg
- D  $10^{-22}$  kg

108 A radioactive nucleus is formed by  $\beta$ -decay. This nucleus then decays by  $\alpha$ -emission. 9702/13/M/J/13/Q40

Which graph of nucleon number  $N$  plotted against proton number  $Z$  shows the  $\beta$ -decay followed by the  $\alpha$ -emission?

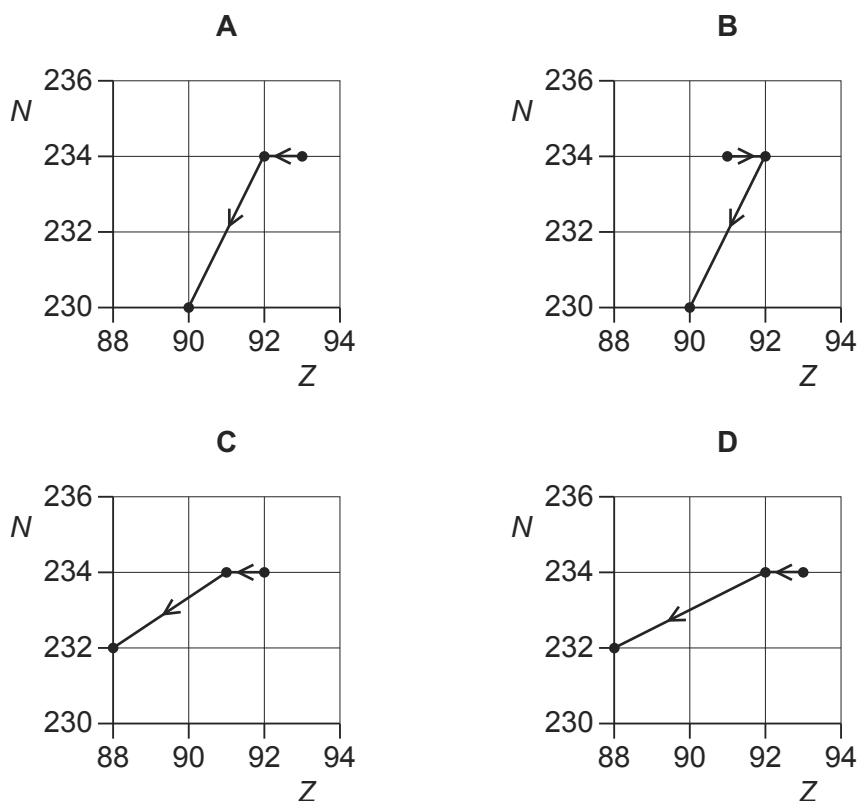

109 The decay of a nucleus of neptunium is accompanied by the emission of a  $\beta$ -particle and  $\gamma$ -radiation. 9702/13/M/J/13/Q39

What effect (if any) does this decay have on the proton number and on the nucleon number of the nucleus?

	proton number	nucleon number
<b>A</b>	increases	decreases
<b>B</b>	decreases	increases
<b>C</b>	unchanged	decreases
<b>D</b>	increases	unchanged



- 110 Scientists investigating the count rate from a radioactive source observed that the count rate fluctuates. 9702/13/M/J/13/Q38

What do these fluctuations imply about the nature of radioactive decay?

- A** It involves atomic nuclei.  
**B** It is predictable.  
**C** It is random.  
**D** It is spontaneous.
- 111 When  $\alpha$ -particles are fired at a thin metal foil, most of the particles pass straight through but a few are deflected by a large angle. 9702/11/O/N/13/Q39

Which change would increase the **proportion** of  $\alpha$ -particles deflected by a large angle?

- A** using  $\alpha$ -particles with greater kinetic energy  
**B** using a foil made of a metal with fewer protons in its nuclei  
**C** using a double thickness foil  
**D** using an alpha source with a higher activity
- 112 Plutonium-239 ( ${}^{239}_{94}\text{Pu}$ ) decays by emitting  $\alpha$ -radiation. 9702/11/O/N/13/Q40

Which nuclide is formed from one of these decay reactions? (The product nuclides are represented by X.)

- A**  ${}^{235}_{92}\text{X}$       **B**  ${}^{237}_{92}\text{X}$       **C**  ${}^{239}_{93}\text{X}$       **D**  ${}^{239}_{95}\text{X}$

- 113 A nucleus of the nuclide  ${}^{228}_{89}\text{Ac}$  decays by emitting a beta particle. The nuclear equation below represents this decay. 9702/13/O/N/13/Q39

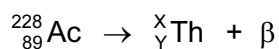

Which pair of values of X and Y is correct?

	X	Y
<b>A</b>	224	87
<b>B</b>	224	89
<b>C</b>	228	88
<b>D</b>	228	90

114 Two  $\alpha$ -particles with equal energies are deflected by a large nucleus.

9702/13/O/N/13/Q40

Which diagram best represents their paths?

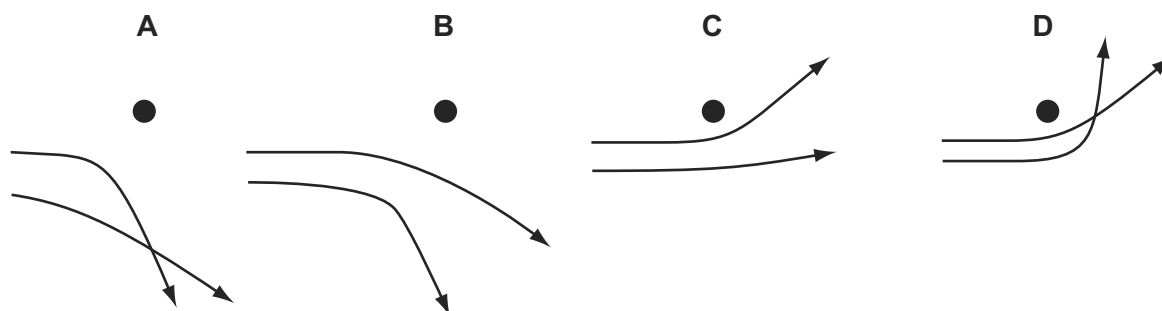

115 A nucleus X decays into a nucleus Y by emitting an alpha particle followed by two beta particles.

9702/12/M/J/14/Q38

Which statement about this nuclear decay is correct?

- A Beta particle decay occurs when a proton changes into a neutron.
- B Nucleus Y has the same nucleon number as nucleus X.
- C Nucleus Y is an isotope of nucleus X.
- D The total mass of the products is equal to the mass of the initial nucleus X.

116 A slow-moving neutron collides with a nucleus of uranium-235. This results in a nuclear reaction that is represented by the following nuclear equation

9702/12/M/J/14/Q39

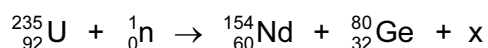

where x represents one or more particles.

What does x represent?

- A one neutron
- B two electrons
- C two neutrons
- D two protons

117 The first artificial radioactive substance was made by bombarding aluminium,  ${}_{13}^{27}\text{Al}$ , with  $\alpha$ -particles. This produced an unstable isotope of phosphorus,  ${}_{15}^{30}\text{P}$ .

9702/12/M/J/14/Q40

What was the by-product of this reaction?

- A an  $\alpha$ -particle
- B a  $\beta$ -particle
- C a neutron
- D a proton

- 118 An isotope of thorium has a nucleon number of 232 and a proton number of 90. It decays to form another isotope of thorium with a nucleon number of 228.

9702/12/M/J/14/Q39

How many alpha particles and beta particles are emitted by a nucleus of thorium during this decay?

	alpha particles	beta particles
<b>A</b>	0	4
<b>B</b>	1	0
<b>C</b>	1	2
<b>D</b>	2	1

- 119 Four nuclei are represented below.

9702/12/M/J/14/Q40



Which statement about these nuclei is correct?

- A** An uncharged atom of element Q has 24 orbital electrons.  
**B** Nucleus M could transform into Q by emitting a beta particle.  
**C** Nuclei G and M are isotopes of the same element.  
**D** When E absorbs a neutron and then emits an alpha particle, nucleus E transforms into M.
- 120 The grid shows a number of nuclides arranged according to the number of protons and the number of neutrons in each.

9702/11/M/J/14/Q40

A nucleus of the nuclide  ${}^8_3\text{Li}$  decays by emitting a  $\beta$ -particle.

What is the resulting nuclide?

number of protons	4					<b>A</b>	<b>B</b>	
	3			${}^6_3\text{Li}$	${}^7_3\text{Li}$	${}^8_3\text{Li}$		
	2		${}^3_2\text{He}$	${}^4_2\text{He}$			<b>C</b>	<b>D</b>
	1	${}^1_1\text{H}$	${}^2_1\text{H}$					
		0	1	2	3	4	5	6
		number of neutrons						

- 121 In 2002, two-proton radioactive decay of an isotope of iron,  ${}^{45}_{26}\text{Fe}$ , was observed. 9702/11/M/J/14/Q38

What could be the resulting product?

- A**  ${}^{43}_{26}\text{Fe}$       **B**  ${}^{43}_{24}\text{Cr}$       **C**  ${}^{45}_{24}\text{Cr}$       **D**  ${}^{47}_{28}\text{Ni}$

- 122  $\text{U}^{++}$  is a doubly-ionised uranium atom. The uranium atom has a nucleon number of 235 and a proton number of 92. 9702/11/M/J/14/Q39

In a simple model of the atom, how many particles are in this ionised atom?

- A** 235      **B** 325      **C** 327      **D** 329

- 123 Alpha, beta and gamma radiations have various depths of penetration in matter and different charges. 9702/11/M/J/14/Q37

Which row best summarises the penetration and charge of each radiation?

	alpha	beta	gamma
<b>A</b>	absorbed by a sheet of card negative charge	absorbed by several mm of aluminium no charge	not fully absorbed by several cm of lead no charge
<b>B</b>	absorbed by a sheet of card negative charge	absorbed by several mm of aluminium positive charge	not fully absorbed by several cm of lead no charge
<b>C</b>	absorbed by a sheet of card positive charge	absorbed by several mm of aluminium negative charge	not fully absorbed by several cm of lead no charge
<b>D</b>	absorbed by several mm of aluminium positive charge	not fully absorbed by several cm of lead negative charge	absorbed by a sheet of card no charge

- 124 Which statement about  $\alpha$ -particles is correct? 9702/11/O/N/14/Q38

- A**  $\alpha$ -particles emitted from a single radioactive isotope have a continuous distribution of energies.
- B**  $\alpha$ -particles have less ionising power than  $\beta$ -particles.
- C** The charge of an  $\alpha$ -particle is  $+1.60 \times 10^{-19} \text{ C}$ .
- D** The speeds of  $\alpha$ -particles can be as high as  $1.5 \times 10^7 \text{ m s}^{-1}$ .

- 125 The isotope  ${}^{222}_{86}\text{Rn}$  decays in a sequence of emissions to form the isotope  ${}^{206}_{82}\text{Pb}$ . At each stage of the decay sequence, it emits either an  $\alpha$ -particle or a  $\beta$ -particle. 9702/11/O/N/14/Q39

What is the number of stages in the decay sequence?

- A** 4                      **B** 8                      **C** 16                      **D** 20

- 126 What is the approximate mass of a nucleus of uranium? 9702/11/O/N/14/Q40

- A**  $10^{-15}$  kg              **B**  $10^{-20}$  kg              **C**  $10^{-25}$  kg              **D**  $10^{-30}$  kg

- 127 The nucleus of a radioactive isotope of an element emits an alpha particle. The daughter nucleus then emits a beta particle and then the daughter nucleus of that reaction emits another beta particle. 9702/13/O/N/14/Q38

Which statement describes the final nuclide that is formed?

- A** It is a different isotope of the original element.  
**B** It is a nuclide of a different element of higher proton number.  
**C** It is a nuclide of the same element but with different proton number.  
**D** It is identical to the original nuclide.

- 128 A nuclear reaction is shown. 9702/13/O/N/14/Q39

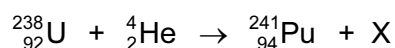

What is product X?

- A** an alpha particle  
**B** an electron  
**C** a neutron  
**D** a proton

- 129 The nuclide  ${}^{222}_{86}\text{Rn}$  decays in a sequence of stages to form the nuclide  ${}^{206}_{82}\text{Pb}$ . 9702/11/M/J/15/Q40

Four of the nuclides formed in the sequence are  $\alpha$ -particle emitters. The others are  $\beta$ -particle emitters.

How many nuclides formed in the decay sequence are  $\beta$ -particle emitters?

- A** 2                      **B** 4                      **C** 8                      **D** 12

## 130 Alpha, beta and gamma radiations

- 1 are absorbed to different extents in solids,
- 2 behave differently in an electric field,
- 3 behave differently in a magnetic field.

The diagrams illustrate these behaviours.

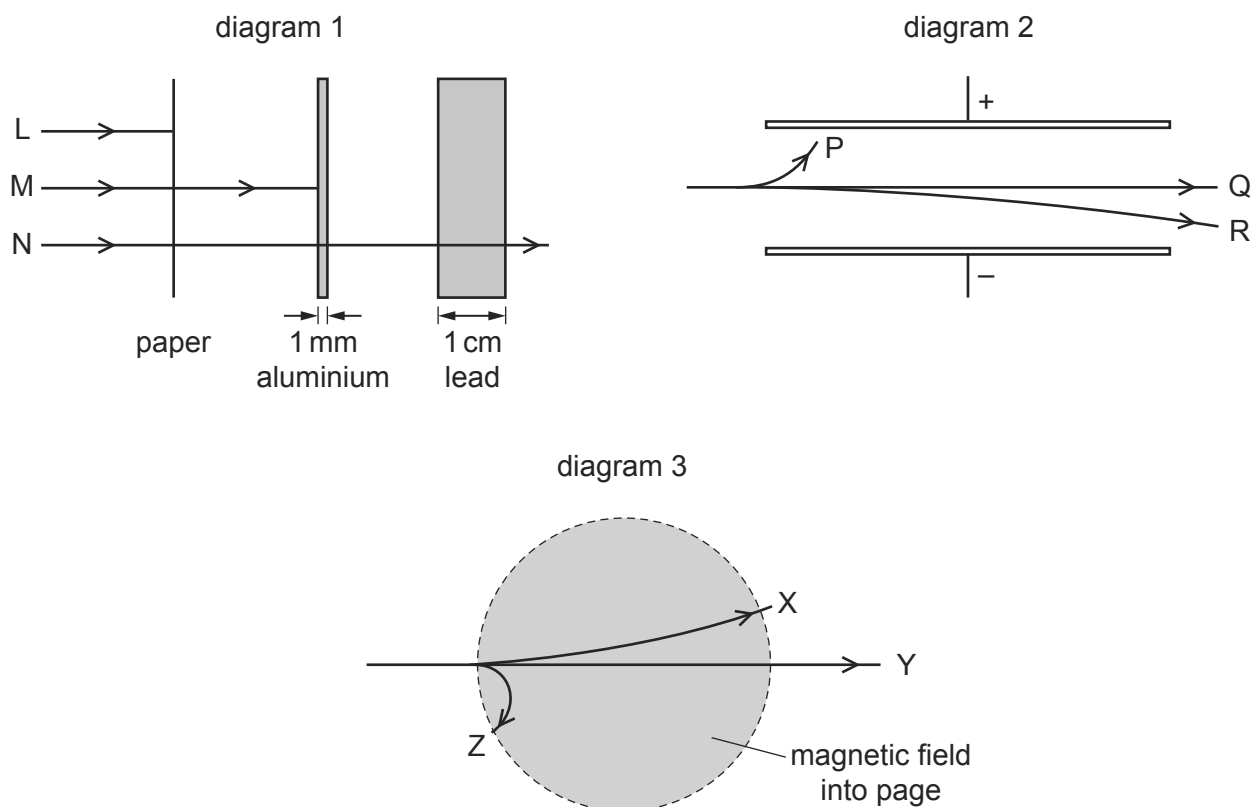

Which three labels on these diagrams refer to the **same** kind of radiation?

- A** L, P, X      **B** L, P, Z      **C** M, P, Z      **D** N, Q, X

## 131 The nuclear equation for a fission reaction is shown below.

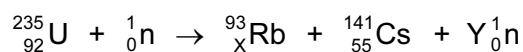

What are the values of X and Y?

	X	Y
<b>A</b>	37	0
<b>B</b>	37	1
<b>C</b>	37	2
<b>D</b>	38	2

- 132 A radioactive substance contains a number of identical nuclei that emit  $\beta$ -particles. 9702/12/M/J/15/Q39

Which property of these nuclei remains unaltered by the emission?

- A charge
- B neutron number
- C nucleon number
- D proton number

- 133 A uranium-238 nucleus,  ${}_{92}^{238}\text{U}$ , undergoes nuclear decays to form uranium-234,  ${}_{92}^{234}\text{U}$ .

9702/12/M/J/15/Q40

Which series of decays could give this result?

- A emission of four  $\beta$ -particles
- B emission of four  $\gamma$ -rays
- C emission of one  $\alpha$ -particle and two  $\beta$ -particles
- D emission of two  $\alpha$ -particles and eight  $\beta$ -particles

- 134 When  $\alpha$ -particles are directed at gold leaf

9702/11/M/J/15/Q39

- 1 almost all  $\alpha$ -particles pass through without deflection,
- 2 a few  $\alpha$ -particles are deviated through large angles.

What are the reasons for these effects?

	1	2
<b>A</b>	most $\alpha$ -particles have enough energy to pass right through the gold leaf	gold is very dense so a few low energy $\alpha$ -particles bounce back from the gold surface
<b>B</b>	most $\alpha$ -particles miss all gold atoms	a few $\alpha$ -particles bounce off gold atoms
<b>C</b>	the gold nucleus is very small so most $\alpha$ -particles miss all nuclei	occasionally the path of an $\alpha$ -particle is close to a nucleus
<b>D</b>	the positive charge in an atom is not concentrated enough to deflect an $\alpha$ -particle	occasionally an $\alpha$ -particle experiences many small deflections in the same direction